

Digital Controller E5□K-T

The E5□K-T Programmable Type Digital Controllers Expand the Variety of E5□K Digital Controllers and are Available in Three Sizes (1/4, 1/8, and 1/16 DIN).



E5□K-T Series



Contents

Digital Controllers	
E5AK-T/E5EK-T	I-123
E5CK-T	I-129
Common to Both Controllers	
• Dimensions	I-133
• Installation	I-135
• Wiring	I-140
• Operation	I-148
• Peripheral Devices	I-158
• Precautions	I-159

Compact and Easy-to-use Controllers

■ Programming is as easy as following the steps below.

Program can be set in pattern 0 according to the following procedure.

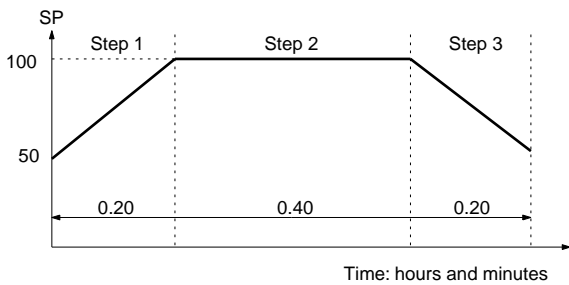

Step No.	Target value	Time (hours.minutes)
0	50	0.00
1	100	0.20
2	100	0.40
3	50	0.20

1. Press the Display Key to shift to the display for the number of steps.

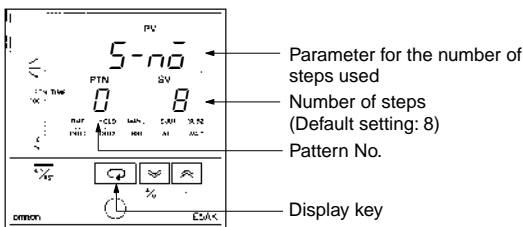

2. Press the Down Key and set the number of steps.

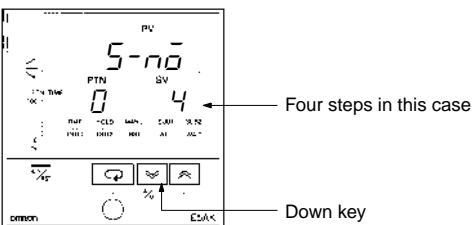

3. Press the Display Key to shift to the display for the target value of step 0.

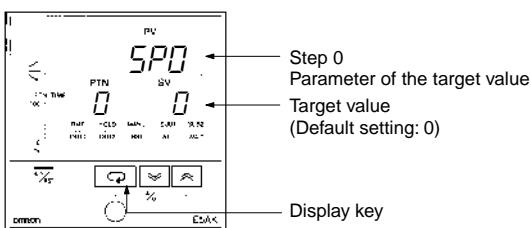

4. Set the target value to "50."

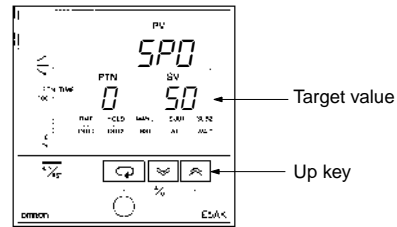

5. Press the Display Key to shift to the display for the time of step 0.

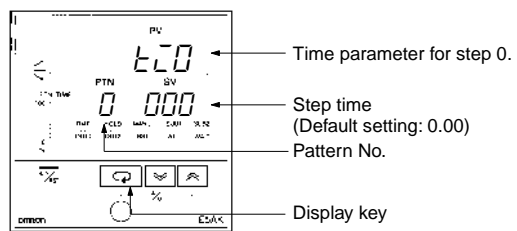

6. Press the Display Key again with the step time set at 0 minutes, and the target value parameter for step 1 will be displayed.

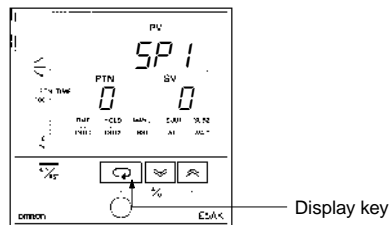

7. Press the Up Key to increment to "100."

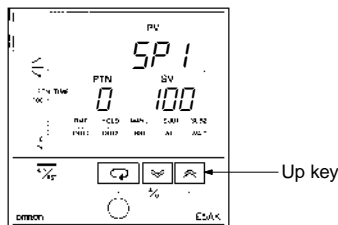

In the same manner, set the time for step 1, target value for step 2, time for step 2, etc.

When the target value and time settings are complete, press the Display Key.

Digital Controller E5AK-T/E5EK-T

Advanced Programmable Digital Controllers Ideal for Worldwide Use

- Offers up to eight patterns of simple programming control (16 steps per pattern).
- Modular structure, one-stock type
- High-accuracy: 100-ms sampling (for analog input)
- Conforms to international EMC and safety standards.
- IP66/NEMA4 (indoor use) front face
- Serial communications (RS-232C, RS-422 and RS-485) and transfer output (4 to 20 mA)
- Position-proportional control model
- Heating/cooling control
- 24VAC/DC types are also available.



Model Number Structure

Model Number Legend

E5□K-T□□□□-500
 1 2 3 4

1. Size

- A: 96 x 96 mm
- E: 96 x 48 mm
- C: 58 x 58 mm

2. Programmable type

- T: Programmable type

3. Model

- AA: Standard model
- PRR: Position-proportional model

4. Number of alarms

- 2: Two alarms

Ordering Information

List of Models

Description	Model	Specification
Base Unit	E5AK-TAA2 AC100-240	Standard model
	E5AK-TAA2-500 AC100-240	Standard model with terminal cover
	E5AK-TAA2 AC/DC24	Standard model
	E5AK-TAA2-500 AC/DC24	Standard model with terminal cover
	E5AK-TPRR2 AC100-240	Position-proportional model
	E5AK-TPRR2-500 AC100-240	Position-proportional model with terminal cover
	E5AK-TPRR2 AC/DC24	Position-proportional model
	E5AK-TPRR2-500 AC/DC24	Position-proportional model with terminal cover
	E5EK-TAA2 AC100-240	Standard model
	E5EK-TAA2-500 AC100-240	Standard model with terminal cover
	E5EK-TAA2 AC/DC24	Standard model
	E5EK-TAA2-500 AC/DC24	Standard model with terminal cover
	E5EK-TPRR2 AC100-240	Position-proportional model
	E5EK-TPRR2-500 AC100-240	Position-proportional model with terminal cover
	E5EK-TPRR2 AC/DC24	Position-proportional model
	E5EK-TPRR2-500 AC/DC24	Position-proportional model with terminal cover

Note: 1. When using the heater burnout alarm function with a standard model, the Linear Output Unit cannot be used for the control outputs (heat).
 2. Be sure to specify the Current Transformer, Output Unit, and Option Unit when ordering.

Description	Model	Specification
Output Unit	E53-R	Relay
	E53-S	SSR
	E53-Q	Pulse (NPN) 12 VDC at 40 mA max.
	E53-Q3	Pulse (NPN) 24 VDC at 20 mA max.
	E53-Q4	Pulse (PNP) 24 VDC at 20 mA max.
	E53-C3	Linear (4 to 20 mA) under a load of 600 Ω max.
	E53-C3D	Linear (0 to 20 mA) under a load of 600 Ω max.
	E53-V34	Linear (0 to 10 V) under a load of 1 kΩ min.
E53-V35	Linear (0 to 5 V) under a load of 1 kΩ min.	

Note: The Digital Controller uses a dedicated, high-resolution Output Unit. The E53-C Current Output Unit for the E5□X cannot be used with the Digital Controller.

Description	Model	Specification
Option Unit	E53-AKB	Event input
	E53-AK01	Communication (RS-232C)
	E53-AK02	Communication (RS-422)
	E53-AK03	Communication (RS-485)
	E53-AKF	Transfer output

- Note:**
1. The Option Unit can be used either by the E5AK or E5EK.
 2. The E5AK allows a maximum of three Option Units to be mounted. Refer to page 133 for mounting combinations. The E5EK allows only one Option Unit to be mounted.

Inspection Report

The Digital Controller can be provided together with an inspection report.

Refer to the following legend with the suffix "K" when ordering a model provided together with an inspection report.
E5□K-TAA2-K, E5□K-TPRR2-K

■ Accessories (Order Separately)

Name	Model	Hole diameter
Current Transformer	E54-CT1	5.8 dia.
	E54-CT3	12.0 dia.

Note: No CT is required unless the heater burnout alarm function is used.

Name	Model	Connectable models
Terminal Cover	E53-COV0809	E5AK
	E53-COV08	E5EK

Unit Label

Model	Y92S-L1
-------	---------

Specifications

■ Ratings

Item	100- to 240-VAC type	24-VAC/VDC type
Supply voltage	100 to 240 VAC, 50/60 Hz	24 VAC/VDC, 50/60 Hz
Power consumption	E5AK: 16 VA E5EK: 15 VA	12 VA, 8 W
Operating voltage range	85% to 110% of rated supply voltage	
Sensor input	Thermocouple: K, J, T, E, L, U, N, R, S, B, W, PLII Platinum resistance thermometer: JPt100, Pt100 Current input: 4 to 20 mA, 0 to 20 mA (Input impedance: 150 Ω) Voltage input: 1 to 5 V, 0 to 5 V, 0 to 10 V (Input impedance: 1 MΩ)	
Control output	According to Output Unit (see <i>Output Unit Ratings and Characteristics</i>)	
Auxiliary output	SPST-NO, 3 A at 250 VAC (resistive load)	
Control method	ON/OFF or 2-PID control (with auto-tuning)	
Setting method	Digital setting using front panel keys	
Indication method	7-segment digital display and LEDs	
Event input	Contact input: ON: 1 kΩ max., OFF: 100 kΩ min. No-contact input: ON: residual voltage: 1.5 V max., OFF: leakage current: 0.1 mA max.	
Transfer output	4 to 20 mA, permissible load impedance: 600 Ω max., resolution: approx. 2,600	
Current Transformer input	Connect an exclusive Current Transformer (E54-CT1 or E54-CT3)	
Other functions	<u>Standard</u> Manual output, heating/cooling control, SP limiter, loop burnout alarm, MV limiter, MV change rate limiter, input digital filter, input shift, run/reset, protect functions, scaling function	

■ Input Ranges

Platinum Resistance Thermometer

Input (switch selectable)		JPt100	Pt100
Range	°C	-199.9 to 650.0	-199.9 to 650.0
	°F	-199.9 to 999.9	-199.9 to 999.9
Setting		0	1

Thermocouple

Input (switch selectable) (see note)	K1	K2	J1	J2	T	E	L1	L2	U	N	R	S	B	W	PLII	
Range	°C	-200 to 1,300	0.0 to 500.0	-100 to 850	0.0 to 400.0	-199.9 to 400.0	0 to 600	-100 to 850	0.0 to 400.0	-199.9 to 400.0	-200 to 1,300	0 to 1,700	0 to 1,700	100 to 1,800	0 to 2,300	0 to 1,300
	°F	-300 to 2,300	0.0 to 900.0	-100 to 1,500	0.0 to 750.0	-199.9 to 700.0	0 to 1,100	-100 to 1,500	0.0 to 750.0	-199.9 to 700.0	-300 to 2,300	0 to 3,000	0 to 3,000	300 to 3,200	0 to 4,100	0 to 2,300
Setting	2	3	4	5	6	7	8	9	10	11	12	13	14	15	16	

Note: Setting number is factory-set to 2 (K1).

Current/Voltage

Input (switch selectable)	Current input		Voltage input		
	4 to 20 mA	0 to 20 mA	1 to 5 V	0 to 5 V	0 to 10 V
Range	One of following ranges depending on results of scaling -1999 to 9999 -199.9 to 999.9 -19.99 to 99.99 -1.999 to 9.999				
Setting	17	18	19	20	21

■ Characteristics

Indication accuracy (see note)	Thermocouple: (±0.3% of indication value or ±1°C, whichever greater) ±1 digit max. Platinum resistance thermometer: (±0.2% of indication value or ±0.8°C, whichever greater) ±1 digit max. Analog input: ±0.2% FS ±1 digit max.
Hysteresis	0.01% to 99.99% FS (in units of 0.01% FS)
Proportional band (P)	0.1% to 999.9% FS (in units of 0.1% FS)
Integral (reset) time (I)	0 to 3,999 s (in units of 1 s)
Derivative (rate) time (D)	0 to 3,999 s (in units of 1 s)
Control period	1 to 99 s (in units of 1 s)
Manual reset value	0.0% to 100.0% (in units of 0.1%)
Alarm setting range	–1,999 to 9,999 or –199.9 or 999.9 (decimal point position dependent on input type or result of scaling)
Set time	0 to 99 hrs 59 min or 0 to 99 min 59 s
Program capacity	8 patterns (E5AK) or 4 patterns (E5EK), 16 steps
Programming method	Time or ramp setting method
Time accuracy	±0.2% (±500 ms) of the set value
Sampling period	Temperature input: 250 ms Analog input: 100 ms
Insulation resistance	20 MΩ min. (at 500 VDC)
Dielectric strength	2,000 VAC, 50/60 Hz for 1 min between terminals of different polarities
Vibration resistance	Malfunction: 10 to 55 Hz, 10 m/s ² (approx. 1G) for 10 min each in X, Y, and Z directions Destruction: 10 to 55 Hz, 20 m/s ² (approx. 2G) for 2 hrs each in X, Y, and Z directions
Shock resistance	Malfunction: 200 m/s ² min. (approx. 20G), 3 times each in 6 directions (100 m/s ² (approx. 10G) applied to the relay) Destruction: 300 m/s ² min. (approx. 30G), 3 times each in 6 directions
Ambient temperature	Operating: –10°C to 55°C (with no icing)/3-year warranty period: –10°C to 50°C Storage: –25°C to 65°C (with no icing)
Ambient humidity	Operating: 35% to 85%
Degree of protection	Front panel: NEMA4 for indoor use (equivalent to IP66) Rear case: IEC standard IP20 Terminals: IEC standard IP00
Memory protection	Non-volatile memory (number of writings: 100,000 operations)
Weight	E5AK: approx. 450 g E5EK: approx. 320 g Mounting bracket: approx. 65 g
EMC	Emission Enclosure: EN55011 Group 1 class A Emission AC Mains: EN55011 Group 1 class A Immunity ESD: EN61000-4-2: 4 kV contact discharge (level 2) 8 kV air discharge (level 3) Immunity RF-interference: ENV50140: 10 V/m (amplitude modulated, 80 MHz to 1 GHz) (level 3) 10 V/m (pulse modulated, 900 MHz) Immunity Conducted Disturbance: ENV50141: 3 V (47 to 68 MHz) 10 V (0.15 to 47 MHz, 68 to 80 MHz) (level 3) Immunity Burst: EN61000-4-4: 2 kV power-line (level 3) 2 kV I/O signal-line (level 4)
Approved standards	UL1092, CSA22.2 No. 142, CSA C22.2 No. 142 Conforms to EN50081-2, EN50082-2, EN61010-1 (IEC1010-1) Conforms to VDE0106/part 100 (Finger Protection), when the separately-ordered terminal cover is mounted.

Note: The indication accuracy of the K1, T, and N thermocouples at a temperature of –100°C max. The indication accuracy of the U, L1, and L2 thermocouples at any temperature is ±2°C ±1 digit maximum.

The indication accuracy of the B thermocouple at a temperature of 400°C max. is unrestricted.

The indication accuracy of the R and S thermocouples at a temperature of 200°C max. is ±3°C ±1 digit maximum.

The indication accuracy of the W thermocouple at any temperature is (±0.3% of the indicated value or ±2°C, whichever is greater) ±1 digit maximum.

The indication accuracy of the PLII thermocouple at any temperature is (±0.3% of the indicated value or ±2°C, whichever is greater) ±1 digit maximum.

■ Output Unit Ratings and Characteristics

Model		Specifications
E53-R	Relay output	5 A at 250 VAC (resistive load)
E53-S	SSR output	1 A at 75 to 250 VAC (resistive load)
E53-Q	Voltage output	NPN: 40 mA at 12 VDC (with short-circuit protection)
E53-Q3		NPN: 20 mA at 24 VDC (with short-circuit protection)
E53-Q4		PNP: 20 mA at 24 VDC (with short-circuit protection)
E53-C3	Linear current output	4 to 20 mA, permissible load impedance: 600 Ω max., resolution: approx. 2,600
E53-C3D		0 to 20 mA, permissible load impedance: 600 Ω max., resolution: approx. 2,600
E53-V34	Linear voltage output	0 to 10 VDC, permissible load impedance: 1 kΩ min., resolution: approx. 2,600
E53-V35		0 to 5 VDC, permissible load impedance: 1 kΩ min., resolution: approx. 2,600

Note: An output relay (1 A at 250 VAC) is mounted on the position-proportional model. (When replacing, use the E53-R.)

■ Option Unit Ratings and Characteristics

Model		Specifications
E53-AKB	Event input	Contact input: ON: 1 kΩ max., OFF: 100 kΩ min. No-contact input: ON: residual voltage 1.5 V max., OFF: leakage current 0.1 mA max.
E53-AK01	Communications	RS-232C Transmission method: Half-duplex
E53-AK02		RS-422 Synchronization method: Start-stop synchronization (asynchronous method)
E53-AK03		RS-485 Baud rate: 1.2/2.4/4.8/9.6/19.2 kbps Transmission code: ASCII
E53-AKF	Transfer output	4 to 20 mA: Permissible load impedance: 600 Ω max. Resolution: approx. 2,600

Note: Event input is used for switching the target value, run or stop command, or automatic and manual mode with an external signal input.

■ Current Transformer Ratings

Dielectric strength	1,000 VAC (for 1 min)
Vibration resistance	50 Hz, 98 m/s ² (10G)
Weight	E54-CT1: approx. 11.5 g; E54-CT3: approx. 50 g
Accessories (E54-CT3 only)	Armature: 2; Plug: 2

■ Heater Burnout Alarm

Max. heater current	Single-phase 50 A VAC (see note 1)
Heater current value display accuracy	±5% FS±1 digit max.
Heater burnout alarm setting range	0.1 to 49.9 A (in units of 0.1 A) (see note 2)
Min. detection ON time	190 ms (see note 3)

- Note:**
1. Use the K2CU-F□□A-□GS (with gate input terminals) for the detection of three-phase heater burnout.
 2. The heater burnout alarm is always OFF if the alarm is set to 0.0 A and always ON if the alarm is set to 50.0 A.
 3. No heater burnout detection or heater current value measurement is possible if the control output (heat) is ON for less than 190 ms.

Nomenclature

E5AK

Pattern Number

Indicates the pattern number.

Program Status Indicators

The top indicator indicates the rising step, the middle indicator indicates the constant step, and the bottom indicator indicates the falling step.

Bar Graph

Indicates the rate of pattern elapsing time at the rate of 20% (5 levels) per one segment.

Operation Indicators

- **OUT1**
Lights when the pulse output function assigned to control output 1 turns ON.
- **OUT2**
Lights when the pulse output function assigned to control output 2 turns ON.
- **SUB1**
Lights when the output function assigned to auxiliary output 1 turns ON.
- **SUB2**
Lights when the output function assigned to auxiliary output 2 turns ON.
- **MANU**
Lights when the manual operation mode.
- **RST**
Lights when the operation is reset.
- **RMT**
Lights during remote operation.
- **AT**
Flashes during auto-tuning.
- **HOLD**
Lights when the program is on hold.
- **WAIT**
Lights when the program is waiting.

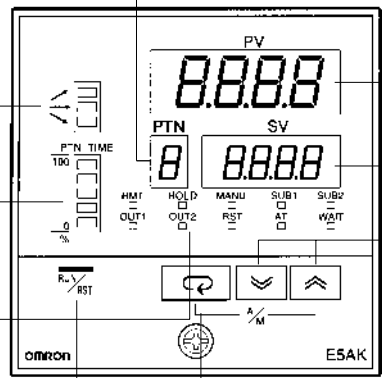

Display 1

Displays the process value or parameter code.

Display 2

Displays the present SP, manipulated variable, or parameter settings.

Up Key/Down Key

Press to increase or decrease the value on the No.2 display.

Display Key

Press to shift the display to the next parameter.

RUN/RST Key

Switches between RUN and RESET mode.

E5EK

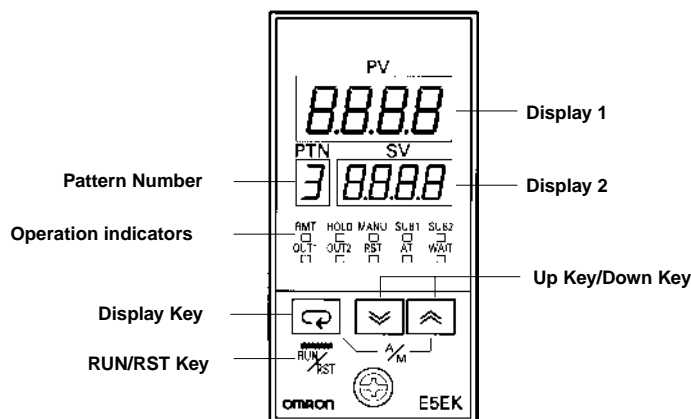

Digital Controller E5CK-T

Advanced, Compact Programmable Digital Controllers Ideal for Worldwide Use

- Offers up to four patterns of simple programming control (16 steps per pattern).
- IP66/NEMA4 (indoor use) front face.
- Modular structure, one-stock type.
- Heating/cooling control.
- Serial communications (RS-232C and RS-485).
- Temperature and analog inputs.
- High-accuracy: 100-ms sampling (for analog input).
- Conforms to international EMC and safety standards.
- 24 VAC/DC types are also available.



Ordering Information

List of Models

Description	Model	Specification
Base Unit	E5CK-TAA1 AC100-240	Standard model
	E5CK-TAA1-500 AC100-240	Standard model with terminal cover
	E5CK-TAA1 AC/DC24	Standard model
	E5CK-TAA1-500 AC/DC24	Standard model with terminal cover

Note: A single Output Unit and Option Unit can be mounted to each Base Unit.

Description	Model	Specification
Output Unit	E53-R4R4	Relay/Relay
	E53-Q4R4	Pulse (NPN)/Relay
	E53-Q4HR4	Pulse (PNP)/Relay
	E53-C4R4	Linear (4 to 20 mA)/Relay
	E53-C4DR4	Linear (0 to 20 mA)/Relay
	E53-V44R4	Linear (0 to 10 V)/Relay
	E53-Q4Q4	Pulse (NPN)/Pulse (NPN)
	E53-Q4HQ4H	Pulse (PNP)/Pulse (PNP)

Description	Model	Specification
Option Unit	E53-CK01	RS-232C
	E53-CK03	RS-485
	E53-CKB	Event input: 1 point
	E53-CKF	Transfer output (4 to 20 mA)

Inspection Report

The Digital Controller can be provided together with an inspection report.

Refer to the following legend with the suffix "K" when ordering a model provided together with an inspection report.

E5CK-TAA1-K

Accessories (Order Separately)

Name	Model
Terminal Cover	E53-COV07

Specifications

■ Ratings

Item	100- to 240-VAC type	24-VAC/VDC type
Supply voltage	100 to 240 VAC, 50/60 Hz	24 VAC/VDC, 50/60 Hz
Power consumption	15 VA	6 VA, 3.5 W
Operating voltage range	85% to 110% of rated supply voltage	
Sensor input	Thermocouple: K, J, T, E, L, U, N, R, S, B, W, PLII Platinum resistance thermometer: JPt100, Pt100 Current input: 4 to 20 mA, 0 to 20 mA Voltage input: 1 to 5 V, 0 to 5 V, 1 to 10 V	
Input impedance	Current input: 150 Ω Voltage input: 1 MΩ min.	
Control output	According to Output Unit (see <i>Output Unit Ratings and Characteristics</i>)	
Auxiliary output	SPST-NO, 3 A at 250 VAC (resistive load)	
Control method	ON/OFF or 2-PID control (with auto-tuning)	
Setting method	Digital setting using front panel keys	
Indication method	7-segment digital display and LEDs	
Other functions	Standard Manual output, heating/cooling control, SP limiter, loop burnout alarm, MV limiter, MV change rate limiter, input digital filter, input shift, run/reset, protect functions, scaling function	

■ Input Ranges

Platinum Resistance Thermometer

Input (switch selectable)		JPt100	Pt100
Range	°C	-199.9 to 650.0	-199.9 to 650.0
	°F	-199.9 to 999.9	-199.9 to 999.9
Resolution (°C/°F) (main setting and alarm)		0	1

Thermocouple

Input (switch selectable) (see note)		K1	K2	J1	J2	T	E	L1	L2	U	N	R	S	B	W	PLII
Range	°C	-200 to 1,300	0.0 to 500.0	-100 to 850	0.0 to 400.0	-199.9 to 400.0	0 to 600	-100 to 850	0.0 to 400.0	-199.9 to 400.0	-200 to 1,300	0 to 1,700	0 to 1,700	100 to 1,800	0 to 2,300	0 to 1,300
	°F	-300 to 2,300	0.0 to 900.0	-100 to 1,500	0.0 to 750.0	-199.9 to 700.0	0 to 1,100	-100 to 1,500	0.0 to 750.0	-199.9 to 700.0	-300 to 2,300	0 to 3,000	0 to 3,000	300 to 3,200	0 to 4,100	0 to 2,300
Resolution (°C/°F) (main setting and alarm)		2	3	4	5	6	7	8	9	10	11	12	13	14	15	16

Note: Setting number is factory-set to 2 (K1).

Current/Voltage

Input (switch selectable)	Current input		Voltage input		
	4 to 20 mA	0 to 20 mA	1 to 5 V	0 to 5 V	0 to 10 V
Range	One of following ranges depending on results of scaling -1999 to 9999 -199.9 to 999.9 -19.99 to 99.99 -1.999 to 9.999				
Resolution (°C/°F) (main setting and alarm)	17	18	19	20	21

■ Characteristics

Indication accuracy (see note 1)	Thermocouple: (±0.3% of indication value or ±1°C, whichever greater) ±1 digit max. Platinum resistance thermometer: (±0.2% of indication value or ±0.8°C, whichever greater) ±1 digit max. Analog input: ±0.2% FS ±1 digit max.
Hysteresis	0.01% to 99.99% FS (in units of 0.01% FS)
Proportional band (P)	0.1% to 999.9% FS (in units of 0.1% FS)
Integral (reset) time (I)	0 to 3,999 s (in units of 1 s)
Derivative (rate) time (D)	0 to 3,999 s (in units of 1 s)
Control period	1 to 99 s (in units of 1 s)
Manual reset value	0.0% to 100.0% (in units of 0.1%)
Alarm setting range	−1,999 to 9,999 or −199.9 or 999.9 (decimal point position dependent on input type)
Program capacity	4 patterns, 16 steps (possible to use up to 4 patterns with the communications function.)
Programming method	Time or ramp setting method
Time accuracy	±0.2% (±500 ms) of the set value
Sampling period (see note 2)	Temperature input: 250 ms Analog input: 100 ms
Insulation resistance	20 MΩ min. (at 500 VDC)
Dielectric strength	2,000 VAC, 50/60 Hz for 1 min between terminals of different polarities
Vibration resistance	Malfunction: 10 to 55 Hz, 10 m/s ² (approx. 1G) for 10 min each in X, Y, and Z directions Destruction: 10 to 55 Hz, 20 m/s ² (approx. 2G) for 2 hrs each in X, Y, and Z directions
Shock resistance	Malfunction: 200 m/s ² min. (approx. 20G), 3 times each in 6 directions (100 m/s ² (approx. 10G) applied to the relay) Destruction: 300 m/s ² min. (30G), 3 times each in 6 directions
Ambient temperature	Operating: −10°C to 55°C (with no icing)/3-year warranty period: −10°C to 50°C Storage: −25°C to 65°C (with no icing)
Ambient humidity	Operating: 35% to 85%
Degree of protection	Front panel: NEMA4 for indoor use (equivalent to IP66) Rear case: IEC standard IP20 Terminals: IEC standard IP00
Memory protection	Non-volatile memory (number of writings: 100,000 operations)
Weight	Approx. 170 g; Adapter: approx. 10 g
EMC	Emission Enclosure: EN55011 Group 1 class A Emission AC Mains: EN55011 Group 1 class A Immunity ESD: EN61000-4-2: 4kV contact discharge (level 2) 8kV air discharge (level 3) Immunity RF-interference: ENV50140: 10V/m (amplitude modulated, 80 MHz to 1 GHz) (level 3) 10 V/m (pulse modulated, 900 MHz) Immunity Conducted Disturbance: ENV50141: 3 V (47 to 68 MHz) 10 V (0.15 to 47 MHz, 68 to 80 MHz) (level 3) Immunity Burst: EN61000-4-4: 2kV power-line (level 3) 2kV I/O signal-line (level 4)
Approved standards	UL1092, CSA22.2 No. 142, CSA C22.2 No. 142 Conforms to EN50081-2, EN50082-2, EN61010-1 (IEC1010-1) Conforms to VDE0106/ part 100 (Finger Protection), when the separately-ordered terminal cover is mounted.

Note: The indication accuracy of the K1, T, and N thermocouples at a temperature of −100°C max. The indication accuracy of the U, L1, and L2 thermocouples at any temperature is ±2°C ±1 digit maximum.
The indication accuracy of the B thermocouple at a temperature of 400°C max. is unrestricted.
The indication accuracy of the R and S thermocouples at a temperature of 200°C max. is ±3°C ±1 digit maximum.
The indication accuracy of the W thermocouple at any temperature is (±0.3% of the indicated value or ±3°C, whichever is greater) ±1 digit maximum.
The indication accuracy of the PLII thermocouple at any temperature is (±0.3% or ±2°C, whichever is greater) ±1 digit maximum.

■ Output Unit Ratings and Characteristics

Model	Control output 1/Control output 2
E53-R4R4	Relay / Relay
E53-Q4R4	Voltage (NPN) / Relay
E53-Q4HR4	Voltage (PNP) / Relay
E53-C4R4	4 to 20 mA / Relay
E53-C4DR4	0 to 20 mA / Relay
E53-V44R4	0 to 10 mA / Relay
E53-Q4Q4	Voltage (NPN) / Voltage (NPN)
E53-Q4HQ4H	Voltage (PNP) / Voltage (PNP)

Output Type	Specifications
Relay	250 VAC, 3 A
Voltage (NPN)	12 VDC, 20 mA (with short-circuit protection)
Voltage (PNP)	12 VDC, 20 mA (with short-circuit protection)
0 to 10 V	0 to 10 VDC, Permissible load impedance: 1 kΩ min., Resolution: Approx. 2600
4 to 20 mA	4 to 20 mA, Permissible load impedance: 500 Ω max., Resolution: Approx. 2600

■ Option Unit Ratings and Characteristics

Model	Specifications
E53-CKB	Event input Contact input: ON: 1 kΩ max., OFF: 100 kΩ min. No-contact input: ON: residual voltage 1.5 V max., OFF: leakage current 0.1 mA max.
E53-CK01	Communications Transmission method: Half-duplex Synchronization method: Start-stop synchronization (asynchronous method) Baud rate: 1.2/2.4/4.8/9.6/19.2 kbps
E53-CK03	
E53-CKF	Transfer output 4 to 20 mA DC: Permissible load impedance: 600 Ω max. Resolution: approx. 2,600

Note: Event input is used for switching the target value, run or stop command, or automatic and manual mode with an external signal input.

Nomenclature

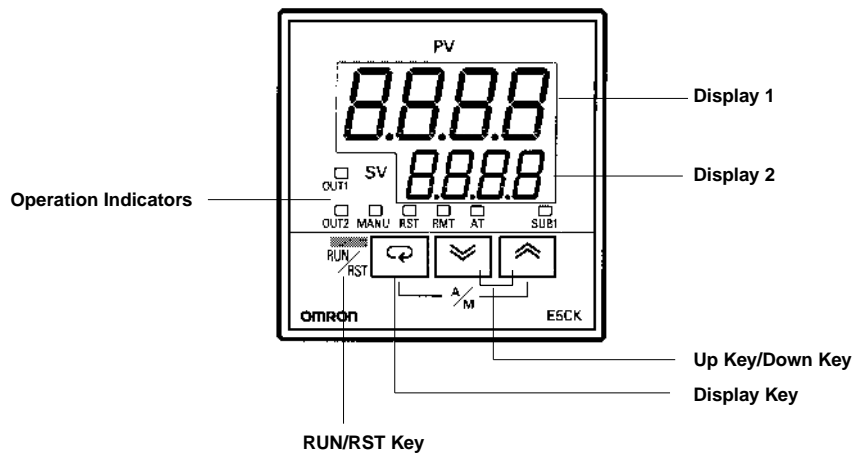

Dimensions

Note: All units are in millimeters unless otherwise indicated.

E5AK

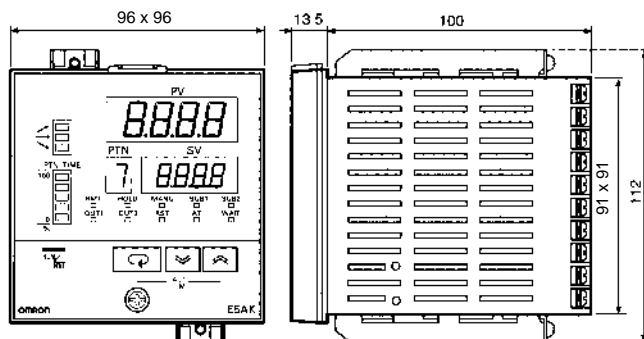

Panel Cutouts

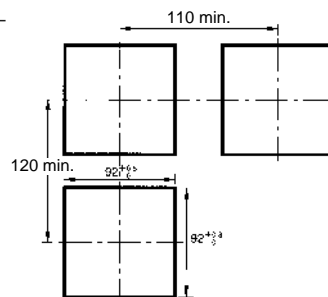

- Note:**
1. Recommended panel thickness is 1 to 8 mm.
 2. Maintain the specified vertical and horizontal mounting space between each Unit. Units must not be closely mounted vertically or horizontally.

E5EK

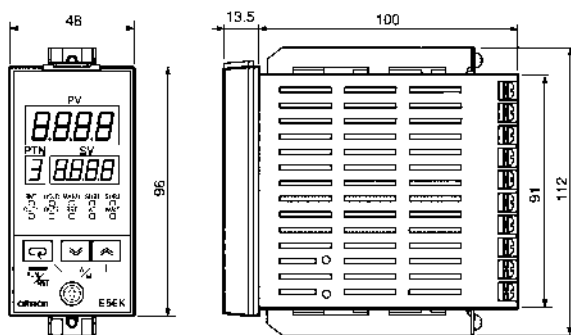
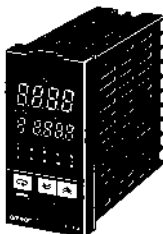

Panel Cutouts

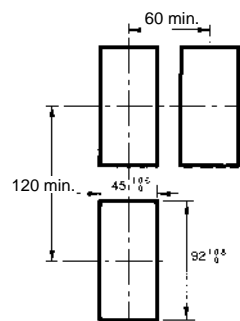

- Note:**
1. Recommended panel thickness is 1 to 8 mm.
 2. Maintain the specified vertical and horizontal mounting space between each Unit. Units must not be closely mounted vertically or horizontally.

E5CK

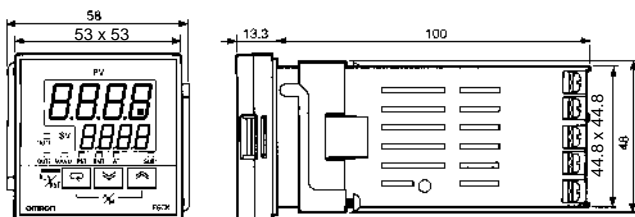

Panel Cutouts

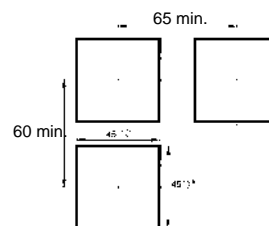

- Note:**
1. Recommended panel thickness is 1 to 5 mm.
 2. Maintain the specified vertical and horizontal mounting space between each Unit. Units must not be closely mounted vertically or horizontally.

Accessories (Order Separately)

Terminal Cover

E53-COV0809 (E5AK)

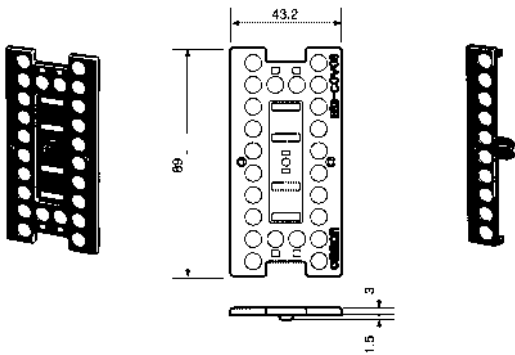

E53-COV08 (E5EK)

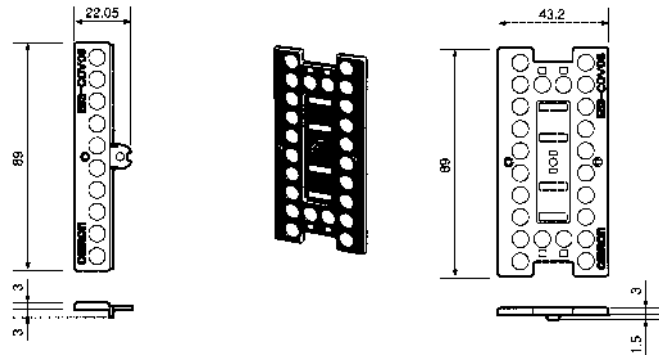

(With rivet)

(With rivet)

E53-COV07

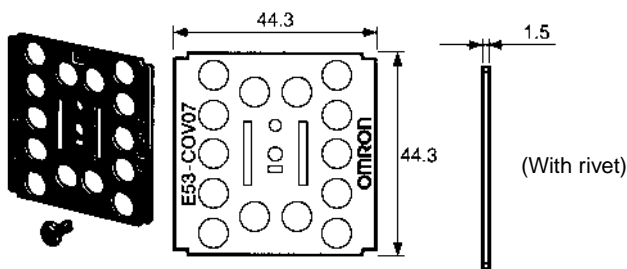

(With rivet)

Current Transformer

E54-CT1

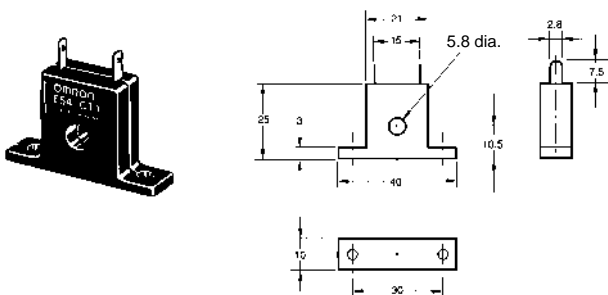

E54-CT3

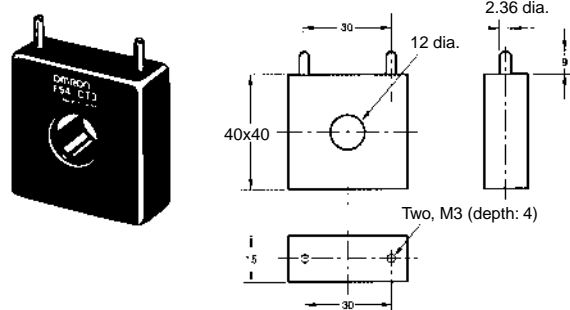

Unit Label (Order Separately)

Y92S-L1

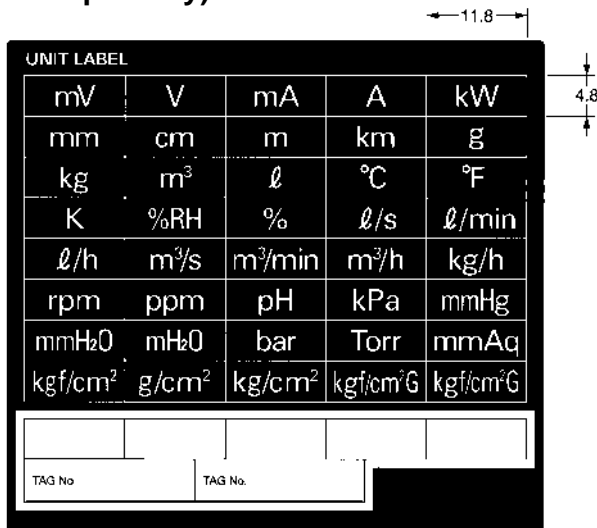

Installation

Note: Always turn OFF the power supply to the Digital Controller before changing any switch settings.

■ Settings (E5AK/E5EK)

On a standard model, set up the Output Units for control outputs 1 and 2 before mounting the Controller.

On a position-proportional model, the Relay Output Unit is already set. Therefore, this setup operation is unnecessary. (Do not replace with other Output Units.)

When setting up the Output Units, draw out the internal mechanism from the housing and insert the Output Units into the sockets for control outputs 1 and 2.

E5AK

Draw-out

When drawing out the internal mechanism from the housing, prepare a Phillips screwdriver matched to the size of the screw on the lower part of the front panel.

1. Press down on the hook on the top of the front panel, and turn the Phillips screwdriver to the left to loosen the screw on the lower part of the front panel.

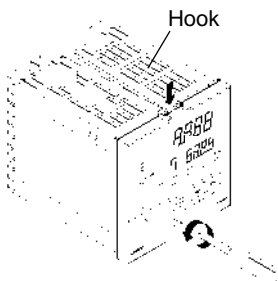

2. Draw out the internal mechanism towards you holding both sides of the front panel.

Setting Up the Output Unit

• Before Setup

Check the type of the Output Unit you are about to set up.

• Procedure

1. Check the positions of the sockets you are about to insert the Output Units into as shown in the following diagram.

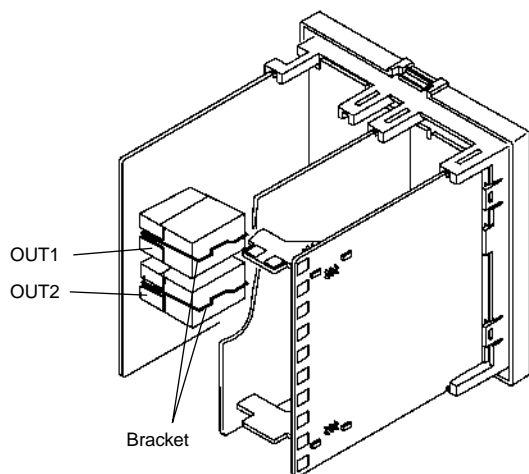

2. Insert the Output Unit for control output 1 into the socket "OUT1" and the Output Unit for control output 2 into the socket "OUT2."
3. Fasten the Output Units with the bracket (accessory).

Setting Up the Option Unit

• Before Setup

Check the type of the Option Unit you are about to set up.

• Procedure

1. Remove the power board and option boards in the order shown in the following diagram.

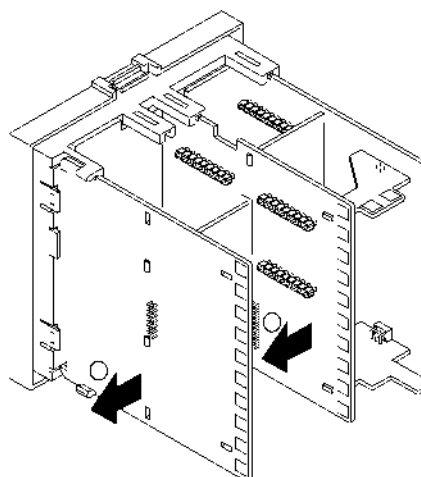

2. Insert the Option Units into the sockets for options 1 to 3. The following diagram shows the relationship between the Option Units and mounting positions.

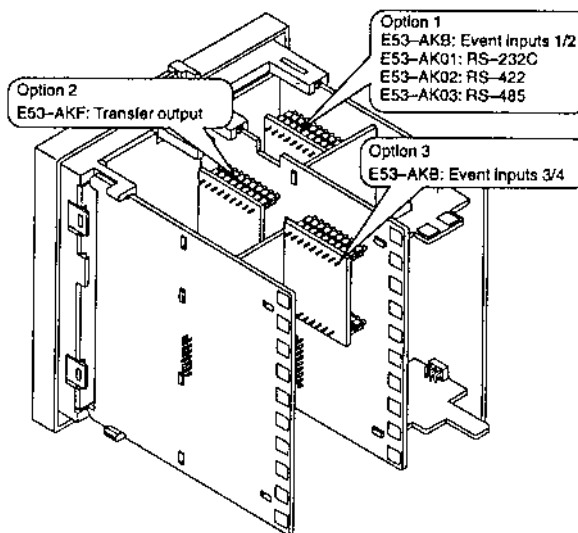

3. Mount the Option Boards and the power board in the order shown.

Mounting

1. Insert the E5AK-T Controller into the mounting hole in the panel.
2. Fit the mounting bracket (accessory) into the fixing slots on the top and bottom of the rear case.

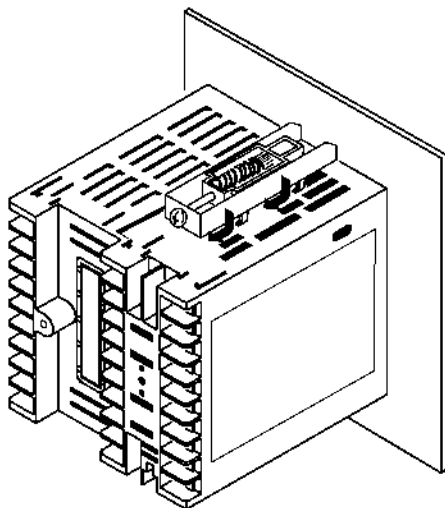

3. Tighten the mounting bracket screws alternately a little at a time until the ratchet starts to slide.

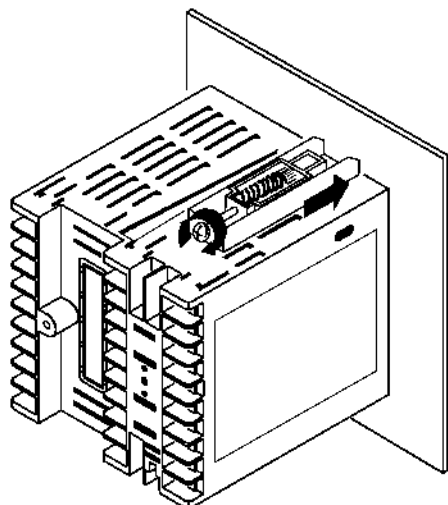

Setting Up the Terminal Cover

Fasten the Terminal Covers (E53-COV0809) to protect terminals.
E5AK-VV2-500 Controller is provided with Terminal Covers.

Use E53-COV09 for terminals 1 to 10, and E53-COV08 for terminals 11 to 33.

Fasten the Terminal Covers as follows by using the snap pins.

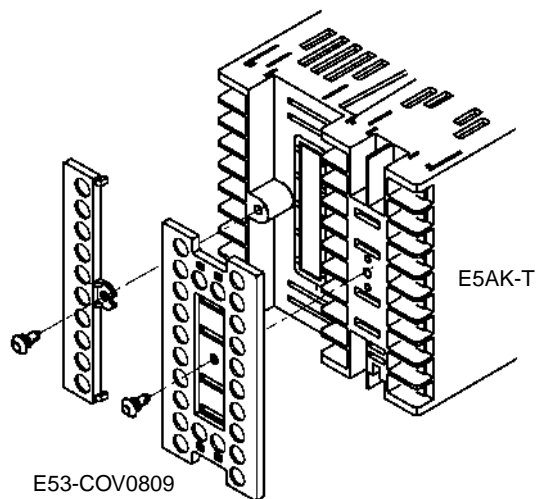

E5EK

Draw-out

When drawing out the internal mechanism from the housing, prepare a Phillips screwdriver matched to the size of the screw on the lower part of the front panel.

1. Press down on the hook on the top of the front panel, and turn the Phillips screwdriver to the left to loosen the screw on the lower part of the front panel.

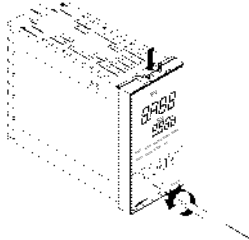

2. Draw out the internal mechanism towards you holding both sides of the front panel.

Setting Up the Output Unit

• Before Setup

Check the type of the Option Unit you are about to set up.

• Procedure

1. Check the positions of the sockets you are about to insert the Output Units into as shown in the following diagram.

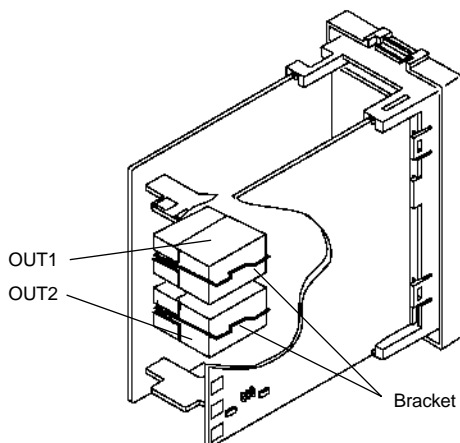

2. Remove the power board in the direction of the arrow in the figure below. The power board is connected to the control board by a connector at the center of the board.

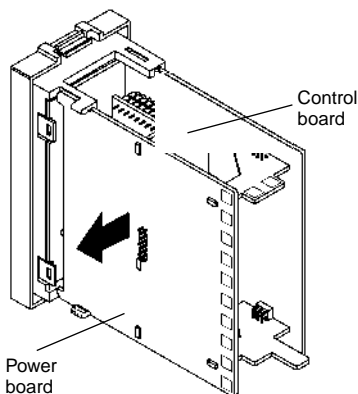

3. Insert the Output Unit for control output 1 into the socket "OUT1" and the Output Unit for control output 2 into the socket "OUT2."
4. Fasten the Output Units with the bracket (accessory).

5. Mount the power board at its original position.

Setting Up the Option Unit

• Before Setup

Check the type of the Option Unit you are about to set up.

• Procedure

1. Remove the power board and Option Boards in the order shown in the following diagram.

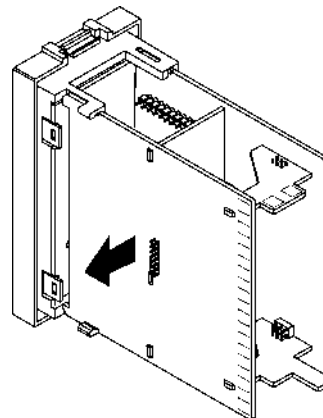

2. Insert the Option Unit into the socket for option 1. The following diagram shows the relationship between Option Unit and mounting position.

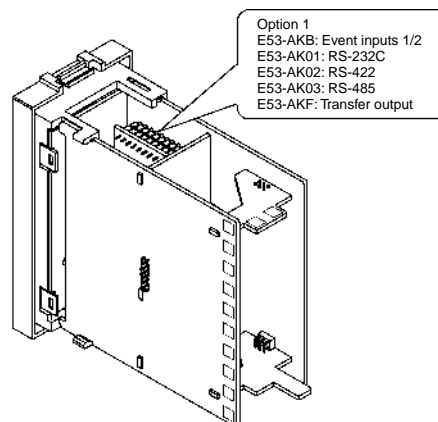

3. Mount the Option Board and the power board in the order shown.

Mounting

1. Insert the E5EK-T Controller into the mounting hole in the panel.
2. Fit the mounting bracket (accessory) into the fixing slots on the top and bottom of the rear case.

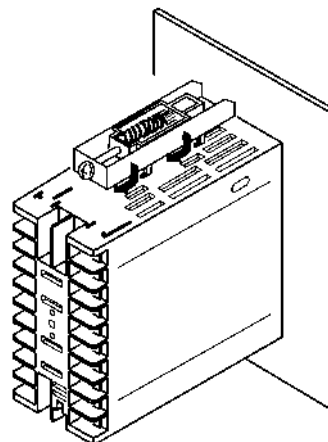

3. Tighten the mounting bracket screws alternately a little at a time until the ratchet starts to slide.

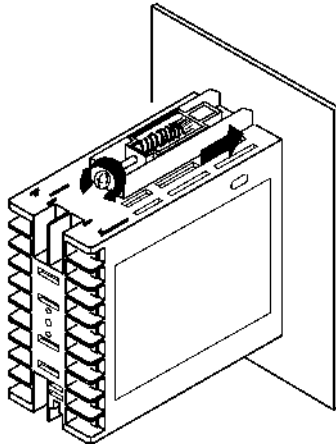

Setting Up the Terminal Cover

Fasten the Terminal Covers (E53-COV0809) to protect terminals.

E5AK-VV2-500 Controller is provided with Terminal Covers.

Use E53-COV09 for terminals 1 to 10, and E53-COV08 for terminals 11 to 33.

Fasten the Terminal Covers as follows by using the snap pins.

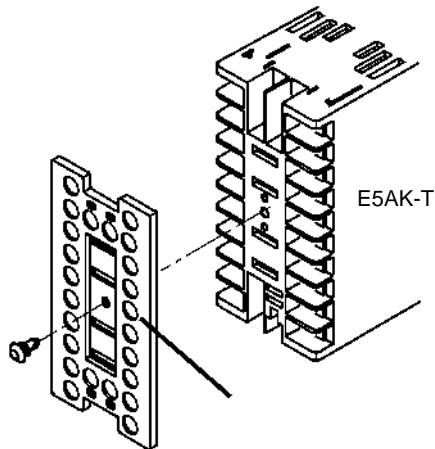

E53-COV08

To remove the Terminal Covers, pull the edges of the snap pins.

E5CK

Draw-out

Draw out the internal mechanism from the housing.

1. Press in both of the hooks on the left and right sides of the front panel to unlock the internal mechanism from the housing.

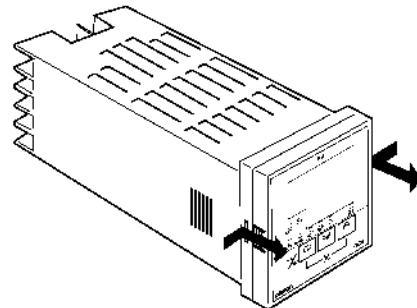

2. Draw out the internal mechanism towards you holding both sides of the front panel.

Setting Up the Output Unit

• Procedure

1. Two rectangular holes for slotting are provided on the power board (on right side of Controller). Fit the two protrusions on the Output Unit into these two holes.
2. With the Output Unit fitted into the power board, fit the Output Unit into the connector on the control board (on left side of Controller).

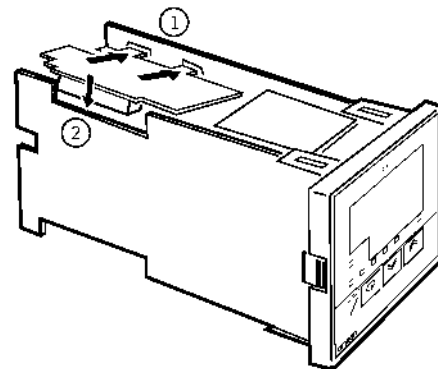

Setting Up the Option Unit

• Procedure

1. Place the Controller with its bottom facing up, and fit the board horizontally into the connector on the power board (on right side of Controller).
2. With the power board connected, fit the board vertically into the connector on the control board (on left side of Controller).

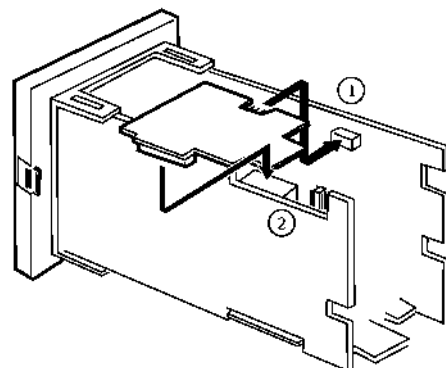

Mounting

1. Insert the E5EK-T Controller into the mounting hole in the panel.
2. Push the adapter along the Controller body from the terminals up to the panel, and fasten temporarily.
3. Tighten the two fixing screws on the adapter. When tightening screws, tighten the two screws alternately keeping the torque to approximately 0.29 to 0.39 N·m, or 3 to 4 kgf·cm.

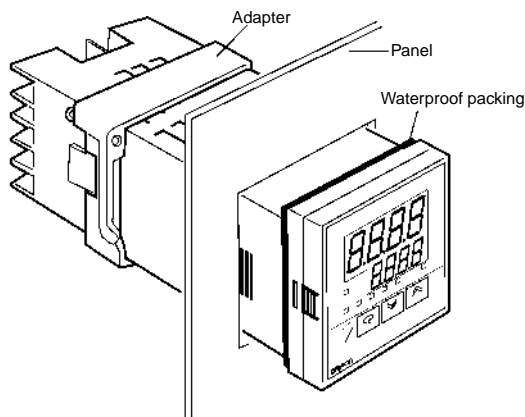

Setting the Input Type Jumper

Set the jumper to one of temperature input, voltage input or current input matched to the type of sensor connected to the input terminal.

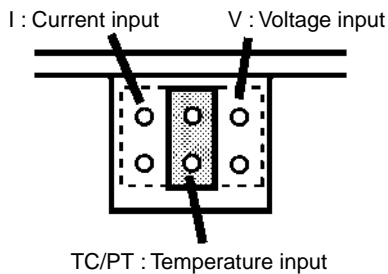

The input type jumper is factory-set to "TC/PT (temperature input)."

When you disconnect or insert the input type jumper, do not hold it directly by its pins.

When you have finished setting the input type jumper, insert the internal mechanism back into the housing.

To do this, push in the internal mechanism until you hear the hooks on the front panel snap into place.

Wiring

■ Wiring Terminals

Terminal Arrangement

E5AK-T

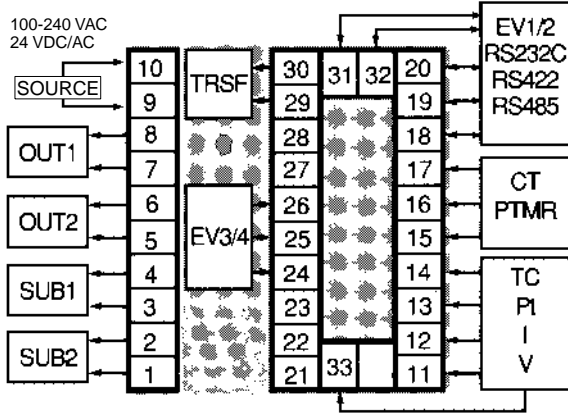

TRSF: Transfer output
EV1 to 4: Event input
PTMR: Potentiometer

E5EK-T

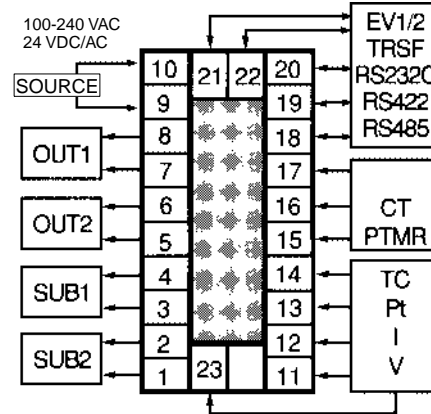

TRSF: Transfer output
EV1/2: Event input
PTMR: Potentiometer

E5CK-T

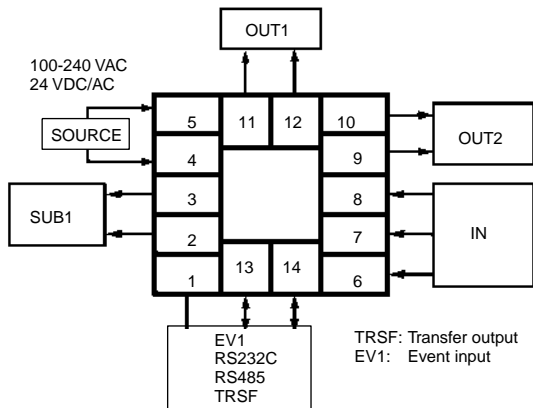

TRSF: Transfer output
EV1: Event input

■ Precautions when Wiring

Use ducts to separate input leads and power lines in order to protect the Controller and its lines from external noise.

Solderless terminals are recommended when wiring the Controller.

Tighten the terminal screws using a torque no greater than 0.78 N·m, or 8 kgf·cm max. Take care not to tighten the terminal screws too tightly.

Power Blocks

The E5AK/E5EK has independent power supplies for each of the terminal blocks shown below.

E5AK

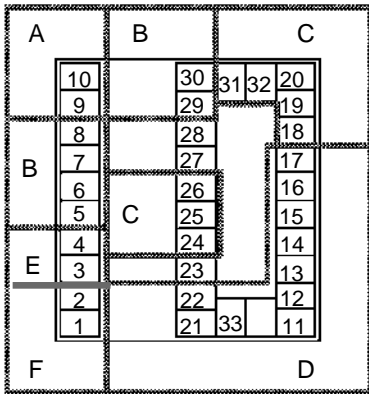

E5EK

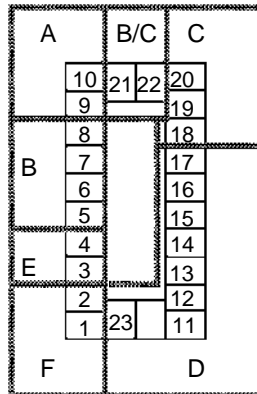

E5CK

The E5CK has independent power supplies for each of the terminal blocks shown below. However, note that the power supplies for blocks C (exclude relay output) and D are shared for the following Option Unit.

- Option Unit: E53-CKB or E53-CKF

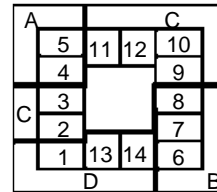

■ E5AK Wiring

In the following wiring diagrams, the left side of the terminal numbers indicate the inside of the Controller.

Power Supply

Input 100 to 240 VAC or 24 VAC/DC to terminal numbers 9 and 10 according to the specifications.

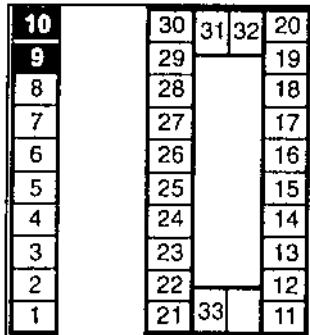

Sensor Input

Connect the sensor input to terminal numbers 11 to 14 and 33 as follows according to the input type.

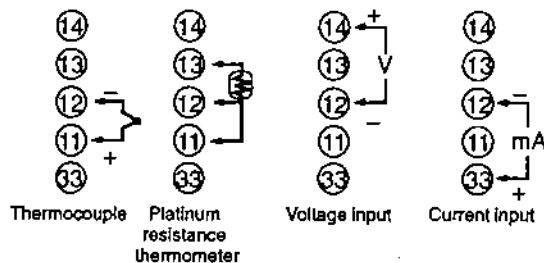
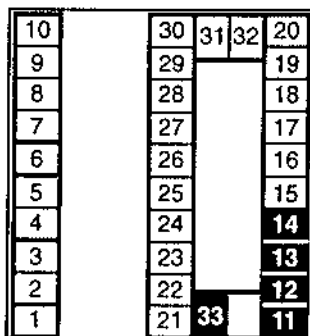

Control Output

Terminal numbers 7 and 8 are for control output 1 (OUT1), and terminal numbers 5 and 6 are for control output 2 (OUT2). The following diagrams show the available Output Units and their internal equalizing circuits.

10		30	31	32	20
9		29			19
8		28			18
7		27			17
6		26			16
5		25			15
4		24			14
3		23			13
2		22			12
1		21	33		11

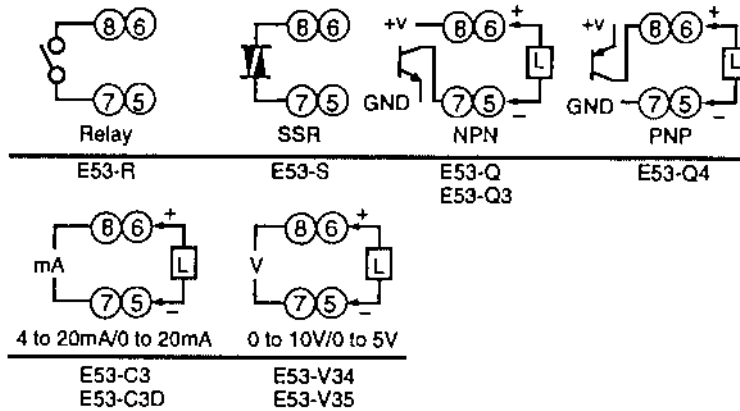

With E53-V□□ Output Units, approx. 2 V is output for one second after the power is interrupted.

With E5AK-TPRR2 Controllers, the relay output (1 A at 250 VAC) is fixed.

When replacing the Output Unit, use the E53-R. The following diagrams show the relationship between terminals and open/close relay settings.

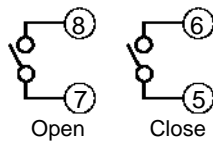

Auxiliary Output

Terminal numbers 3 and 4 are for auxiliary output 1 (SUB1) and terminal numbers 1 and 2 are for auxiliary output 2 (SUB2). The following diagrams show the internal equalizing circuits for the auxiliary outputs:

10		30	31	32	20
9		29			19
8		28			18
7		27			17
6		26			16
5		25			15
4		24			14
3		23			13
2		22			12
1		21	33		11

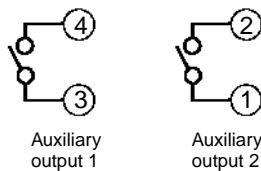

Output specifications are as follows:
SPST-NO, 3 A at 250 VAC

CT Input/Potentiometer

When using the HBA function on the E5AK-AA2 Controller, connect CT input (CT) to terminal numbers 15 to 17. When monitoring the valve opening on the E5AK-PRR2 Controller, connect the potentiometer (PTMR) to terminal numbers 15 to 17. Connect each of these inputs as follows:

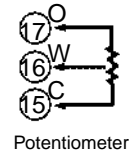
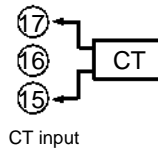
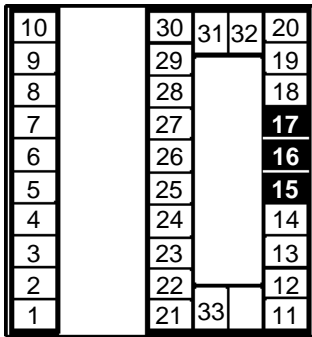

Event Input

Connect event inputs 1 and 2 (EV1/2) to terminal numbers 18 to 20, and event events 3 and 4 (EV3/4) to terminal numbers 24 to 26. However, note that terminal numbers 18 to 20 cannot be used on Controllers with a communications function. Connect the event inputs as follows:

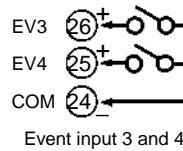
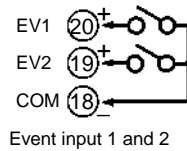
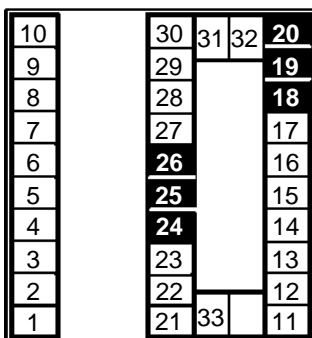

Terminals 18 and 24 (COM) are connected internally.

Use event inputs under the following conditions:

Contact input	ON: 1 kΩ max. OFF: 100 kΩ min.
No-contact input	ON: Residual voltage 1.5 V max., OFF: Leakage current 0.1 mA max.

Polarities during no-contact input are as follows:

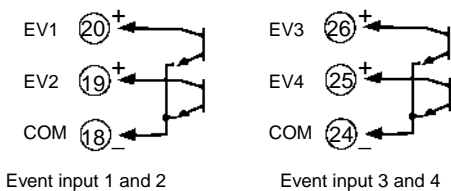

Transfer Output

Connect transfer output (TRSF) to terminal numbers 29 and 30. The internal equalizing circuit for transfer output is as follows:



Transfer output specifications are as follows: 4 to 20 mA DC,
Permissible load impedance: 600 Ω max.,
Resolution: Approx. 2,600

Communications

Terminal numbers 18 to 20, 31 and 32 can be used only on Controllers with Communications Units (E53-AK01/02/03). For details on wiring, refer to Chapter 6, Using the Communications Function in the E5AK-T/E5EK-T/E5CK-T User's Manual (H88/H89/H90).

E5EK Wiring

In the following wiring diagrams, the left side of the terminal numbers indicate the inside of the Controller.

Power Supply

Input 100 to 240 VAC or 24 VAC/DC to terminal numbers 9 and 10 according to the specifications.

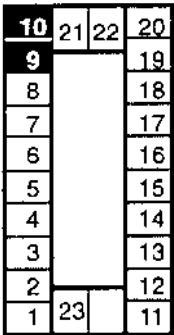

Sensor Input

Connect the sensor input to terminal numbers 11 to 14 and 23 as follows according to the input type.

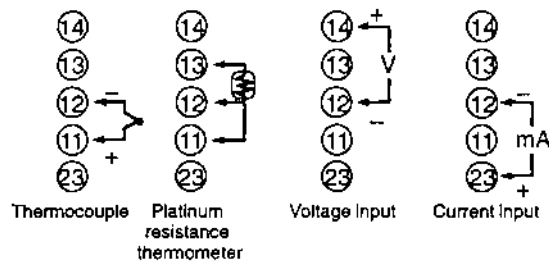
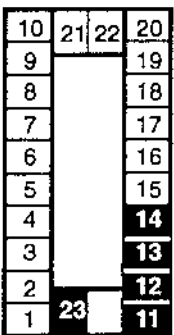

Control Output

Terminal numbers 7 and 8 are for control output 1 (OUT1), and terminal numbers 5 and 6 are for control output 2 (OUT2). The following diagrams show the available Output Units and their internal equalizing circuits.

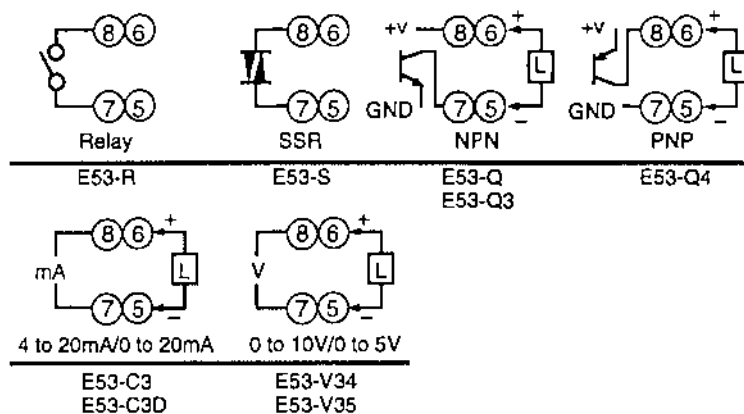
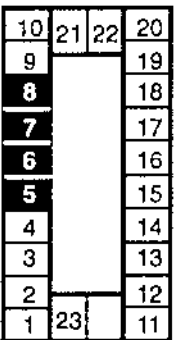

With E53-V□□ Output Units, approx. 2 V is output for one second after the power is interrupted.

With E5EK-TPRR2 Controllers, the relay output (1 A at 250 VAC) is fixed.

When replacing the Output Unit, use the E53-R. The following diagrams show the relationship between terminals and open/close relay settings.

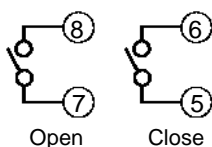

Auxiliary Output

Terminal numbers 3 and 4 are for auxiliary output 1 (SUB1) and terminal numbers 1 and 2 are for auxiliary output 2 (SUB2). The following diagrams show the internal equalizing circuits for the auxiliary outputs:

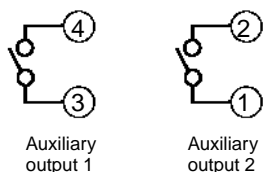
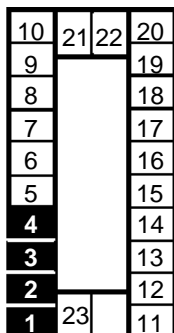

Output specifications are as follows:
SPST-NO, 3A at 250 VAC

CT Input/Potentiometer

When using the HBA function on the E5EK-AA2 Controller, connect CT input (CT) to terminal numbers 15 to 17. When monitoring the valve opening on the E5EK-TPRR2 Controller, connect the potentiometer (PTMR) to terminal numbers 15 to 17. Connect each of these inputs as follows:

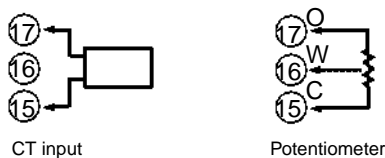
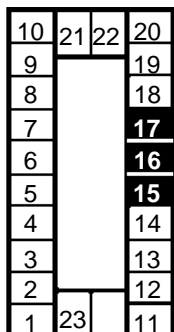

For details on CT inputs, refer to *Appendix, About Current Transformer* in the *E5AK-T/E5EK-T/E5CK-T User's Manual (H88/H89/H90)*. For details on the potentiometer, refer to the *Instruction Manual* for the valve connected to the Controller. The variable resistance range is 100 Ω to 2.5 kΩ.

Event Input

Connect event inputs 1 and 2 (EV1/2) to terminal numbers 18 to 20. However, note that terminal numbers 18 to 20 cannot be used on Controllers with a communications function. Connect the event inputs as follows:

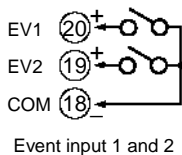
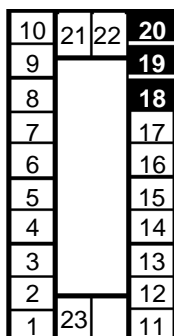

Use event inputs under the following conditions:

Contact input	ON: 1 kΩ max., OFF: 100 kΩ min.
No-contact input	ON: Residual voltage 1.5 V max., OFF: Leakage current 0.1 mA max.

Polarities during no-contact input are as follows:

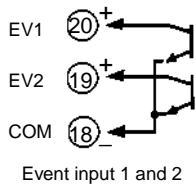

Transfer Output

Connect transfer output (TRSF) to terminal numbers 21 and 22. The internal equalizing circuit for transfer output is as follows:

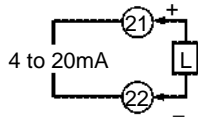

Transfer output specifications are as follows: 4 to 20 mA DC,
Permissible load impedance: 600 Ω max.,
Resolution: Approx. 2,600

Communications

Terminal numbers 18 to 22 can be used only on Controllers with Communications Units (E53-AK01/02/03). For details on wiring, refer to *Chapter 6, Using the Communications Function* in the *E5AK-T/E5EK-T/E5CK-T User's Manual (H88/H89/H90)*.

■ E5CK Wiring

Power Supply

Input 100 to 240 VAC or 24 VAC/DC to terminal numbers 4 and 5 according to the specification.

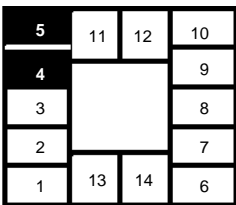

Sensor Input

Connect the input to terminal numbers 6 to 8 as follows according to the input type.

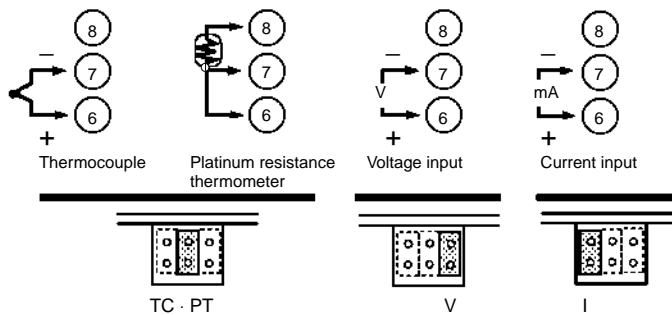
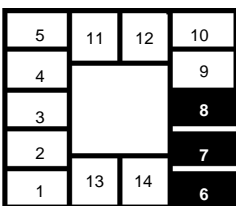

Match the inputs with the internal jumper settings for each input type. For thermocouple or platinum resistance thermometer inputs, set the inputs to a common position (TC/PT) as the temperature input.

Control Output

Terminal numbers 11 and 12 are for control output 1 (OUT1). The five output types and internal equalizing circuits are available according to the Output Unit.

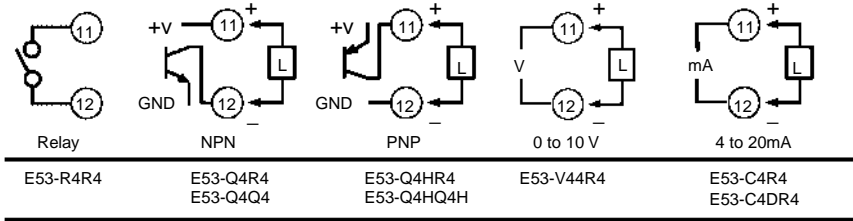
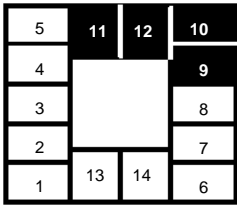

Terminal numbers 9 and 10 are for control output 2 (OUT2). The three output types and internal equalizing circuits are available according to the Output Unit.

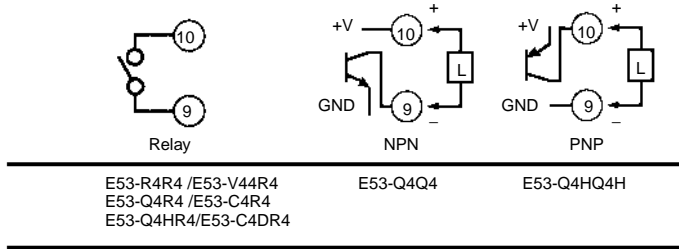

Auxiliary Output 1

Terminal numbers 2 and 3 are for auxiliary output 1 (SUB1). The internal equalizing circuit for auxiliary output 1 is as follows:

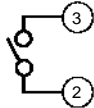
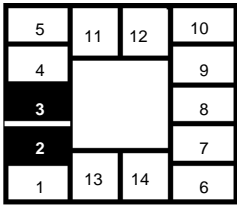

Relay specifications are as follows:
SPST-NO, 250 VAC, 1 A

Option

Terminal numbers 1, 13, and 14 are valid only when the Option Unit is set in the Controller. The following four connections are possible depending on the model of the Option Unit.

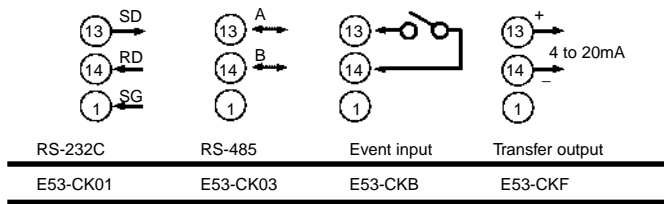
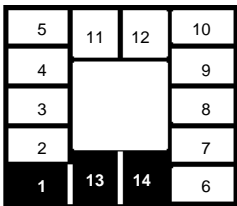

Use event inputs under the following conditions:

Contact input	ON: 1 kΩ max., OFF: 100 kΩ min.
No-contact input	ON: residual voltage 1.5 V max., OFF: leakage current 0.1 mA max.

The polarity for no-contact input is as follows:

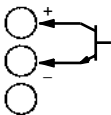

Transfer output specifications are as follows:
4 to 20 mA DC, load: 500 Ω max., resolution approx. 2,600

Operation

■ After Turning ON Power

Determine the I/O specifications of the Digital Controller in setup mode.

Setup Mode

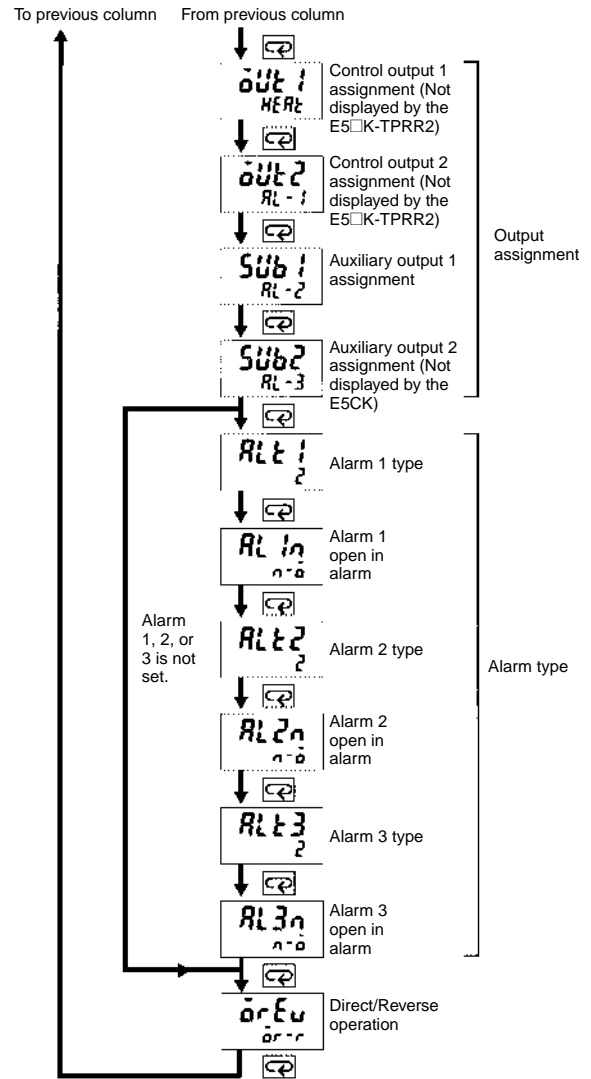
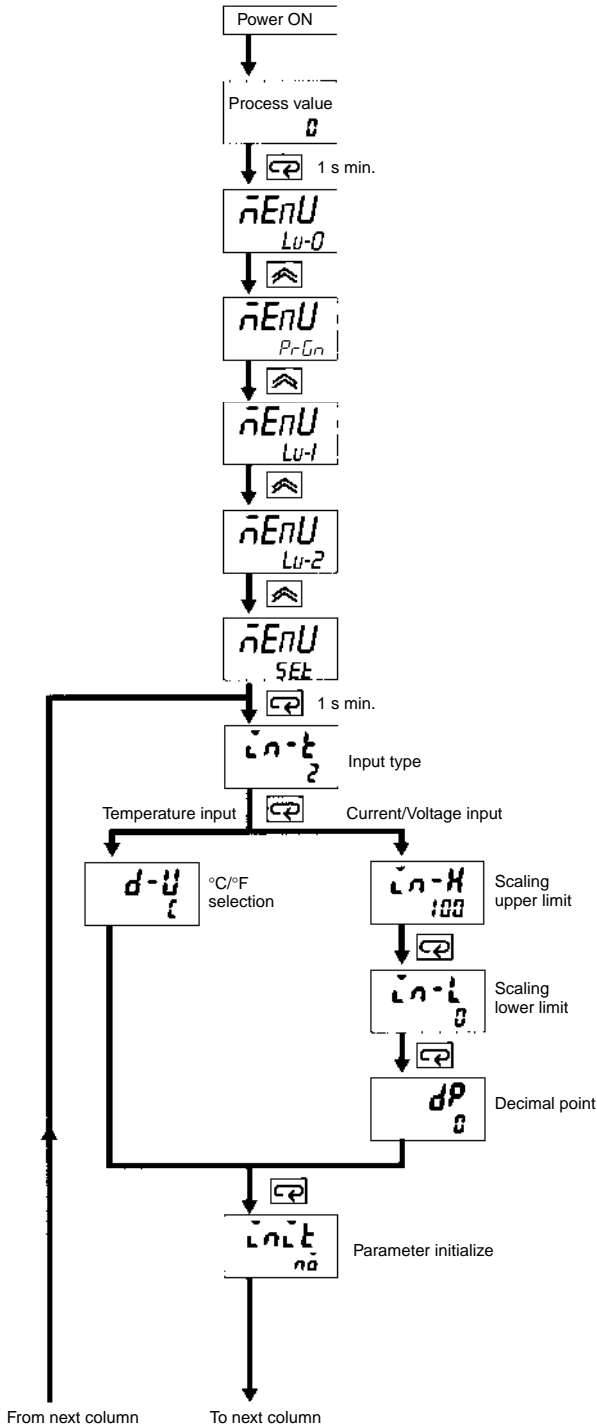

Note: Parameter Initialize
 Parameter initialization sets all parameters to default values except for the input type, scaling upper limit, scaling lower limit, decimal point, and °C/°F selection parameters.

Input Type

Set the code according to the following table. Default is "2: K1 thermocouple."

Platinum Resistance Thermometer

Set value	Input type		
0	JPt100	-199.9 to 650.0 (°C) /-199.9 to 999.9 (°F)	Platinum resistance thermometer
1	Pt100	-199.9 to 650.0 (°C) /-199.9 to 999.9 (°F)	
2	K1	-200 to 1,300 (°C) /-300 to 2,300 (°F)	Thermocouple
3	K2	0.0 to 500.0 (°C) /0.0 to 900.0 (°F)	
4	J1	-100 to 850 (°C) /-100 to 1,500 (°F)	
5	J2	0.0 to 400.0 (°C) /0.0 to 750.0 (°F)	
6	T	-199.9 to 400.0 (°C) /-199.9 to 700.0 (°F)	
7	E	0 to 600 (°C) /0 to 1,100 (°F)	
8	L1	-100 to 850 (°C) /-100 to 1,500 (°F)	
9	L2	0.0 to 400.0 (°C) /0.0 to 750.0 (°F)	
10	U	-199.9 to 400.0 (°C) /-199.9 to 700.0 (°F)	
11	N	-200 to 1,300 (°C) /-300 to 2,300 (°F)	
12	R	0 to 1,700 (°C) /0 to 3,000 (°F)	
13	S	0 to 1,700 (°C) /0 to 3,000 (°F)	
14	B	100 to 1,800 (°C) /300 to 3,200 (°F)	
15	W	0 to 2,300 (°C) /0 to 4,100 (°F)	
16	PLII	0 to 1,300 (°C) /0 to 2,300 (°F)	
17	4 to 20 mA		Current input
18	0 to 20 mA		
19	1 to 5 V		Voltage input
20	0 to 5 V		
21	0 to 10 V		

Output Assignments

Thirteen output functions are available. Allocate these functions to the control outputs 1 and 2 and auxiliary outputs 1 and 2.

There are some limitations on some output function allocations.

Output function types and allocation limitations are as described in the following.

Identical output functions cannot be allocated doubly to the control output 1 or 2 and auxiliary output 1 or 2.

Standard Models

Assignment Destination \ Output Function	Control Output		Auxiliary Output	
	1	2	1	2
Control output (heat) (see note 1)	Yes	Yes	No	No
Control output (cool) (see note 1)	Yes	Yes	No	No
Alarm 1	Yes	Yes	Yes	Yes
Alarm 2	Yes	Yes	Yes	Yes
Alarm 3	Yes	Yes	Yes	Yes
HBA (see notes 1, 2)	Yes	Yes	Yes	Yes
LBA (see note 1)	Yes	Yes	Yes	Yes
Time signal 1	Yes	Yes	Yes	Yes
Time signal 2	Yes	Yes	Yes	Yes
Program end	Yes	Yes	Yes	Yes
Stage output (see note 1)	Yes	Yes	Yes	Yes
Error 1 : Input error	No	No	Yes	Yes
Error 2 : A/D convertor error	No	No	Yes	Yes

Note: 1. Assignment is not possible with the control valve control type.

2. Heater burnout alarm is not available for the E5CK.

Position-proportional Models

Position-proportional-type Controllers support nine output functions. These are assigned to auxiliary outputs 1 and 2.

Restrictions on assignment destinations are placed on some of the outputs. The following table shows where outputs may be assigned to.

Assignment Destination \ Output Function	Control Output		Auxiliary Output	
	1	2	1	2
Alarm 1	No	No	Yes	Yes
Alarm 2	No	No	Yes	Yes
Alarm 3	No	No	Yes	Yes
Time signal 1	No	No	Yes	Yes
Time signal 2	No	No	Yes	Yes
Stage output	No	No	Yes	Yes
Program end output	No	No	Yes	Yes
Error 1 : Input error	No	No	Yes	Yes
Error 2 : A/D converter error	No	No	Yes	Yes

With control output (cool), the conditions for switching from standard control to heating and cooling control are reached when the output function is assigned at the cooling side during heating and cooling control.

In other words, heating and cooling control is carried out when control output (cool) is assigned, and standard control is carried out when output is not assigned.



LBA

The LBA (loop break alarm) function is available when it is assigned as an output. The LBA function is not available when a memory or A/D converter error results.

LBA is a function for determining that an error has occurred somewhere on the control loop and outputting an alarm when the process value does not change with the manipulated variable at a maximum or minimum state. Accordingly, the LBA function can be used as a means for detecting a malfunctioning control loop.

Alarm Mode Selectors

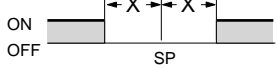
Alarm outputs are available if they are allocated as outputs. Factory setting is "2: Upper-limit alarm (deviation)."

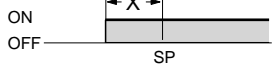
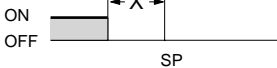
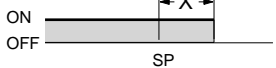
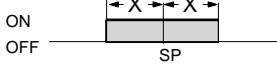
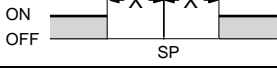
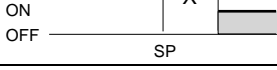
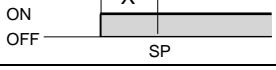
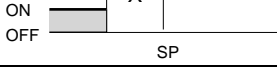
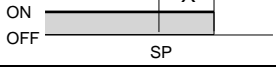
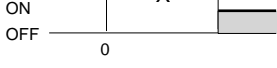
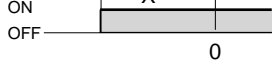
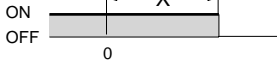
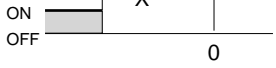
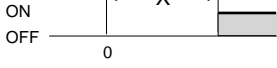
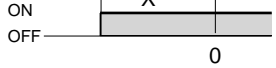
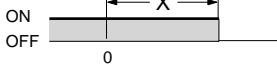
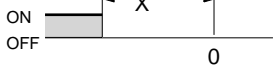
Switch setting	Alarm operation	Alarm output	
		When X is positive	When X is negative
1	Upper- and lower-limit alarm (deviation)		Always ON
2	Upper-limit alarm (deviation)		
3	Lower-limit alarm (deviation)		
4	Upper- and lower-limit range alarm (deviation)		Always OFF
5	Upper- and lower-limit alarm with standby sequence (deviation)		Always OFF
6	Upper-limit alarm with standby sequence (deviation)		
7	Lower-limit alarm with standby sequence (deviation)		
8	Absolute-value upper-limit alarm		
9	Absolute-value lower-limit alarm		
10	Absolute-value upper-limit alarm with standby sequence		
11	Absolute-value lower-limit alarm with standby sequence		

Deviation Alarm

If the alarm mode selector is set to a number between 1 to 7, alarm values are set to the width deviated from the set point as shown in the following illustration.

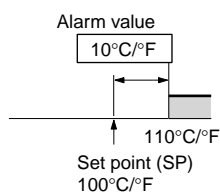

Absolute Alarm

If the alarm mode selector is set to 8 or 9, alarm values are set to the absolute value based on 0°C/°F as shown in the following illustration.

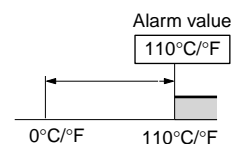

Close in Alarm/Open in Alarm

When the Controller is set to “close in alarm,” the status of the alarm output function is output as it is. When set to “open in alarm,” the status of the alarm output function is output inverted.

Condition	Alarm	Output	Output LED
Close in alarm	ON	ON	Lit
	OFF	OFF	Not lit
Open in alarm	ON	OFF	Lit
	OFF	ON	Not lit

Alarm type and close in alarm (normally open)/open in alarm (normally close) can be set independently from each alarm.

Close in alarm/Open in alarm is set in the “alarm 1 to 3 open in alarm” parameters (setup mode). Factory setting is “close in alarm” [0-0].

Parameter Operation List

Switching to modes other than manual or protect mode is carried out using the mode selection in the menu display.

The figure below shows all parameters in the order that they are displayed. Some parameters are not displayed depending on the protect mode setting and conditions of use.

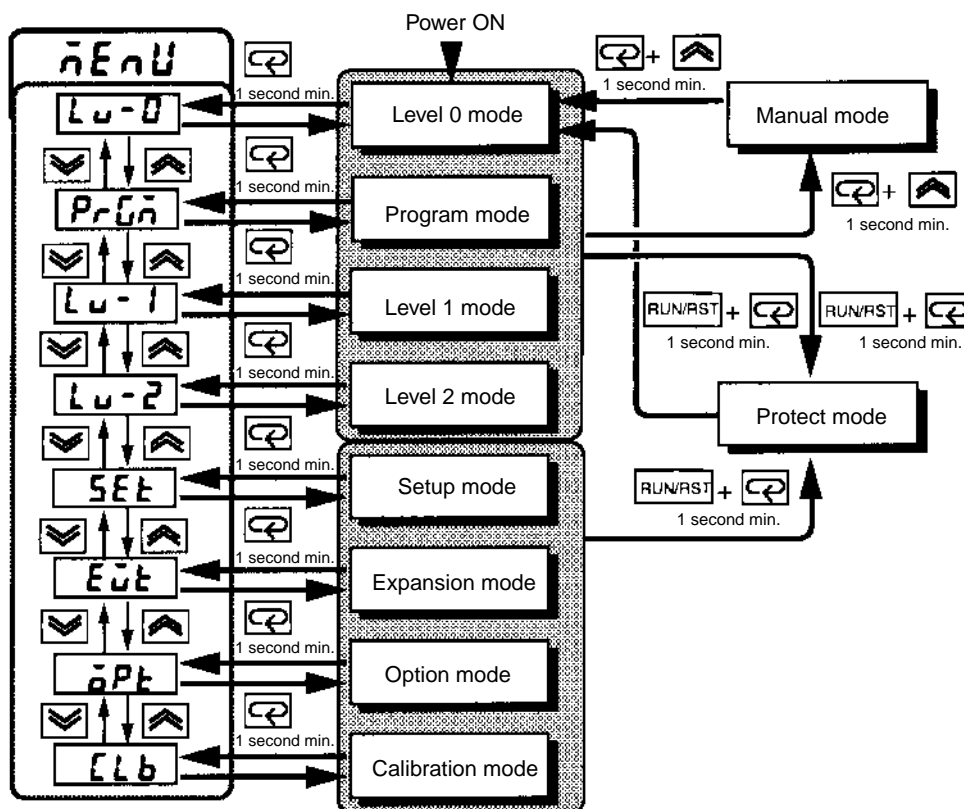

Parameters and Menus

Note: For more details on the functions of each part and display contents, refer to the *E5AK-T/E5EK-T/E5CK-T User's Manual (H88/H89/H90)*.

- Protect Mode** The protect function is for preventing unwanted modification of parameters and switching between run and reset operation or auto and manual operation.
- Manual Mode** In this mode, the Controller can be switched to manual operation. The manipulated variable can be manipulated manually only in this mode.
- Level 0 Mode** Set the Controller to this mode during normal operation. In this mode, you can change the set point and pattern during operation, and execute step operation (e.g. advance). You can only monitor (not change) the process value, step No., standby time, pattern elapsing time, pattern execution count, and manipulated variable.
- Program Mode** This is the programming mode. In this mode, you can set the number of steps used in each pattern, pattern execution count, alarm values, set points for each step, step time, and time signals for two steps.

Level 1 Mode	This is the main mode for adjusting control. In this mode, you can execute AT (auto-tuning), and set up the control period, PID parameters and heater burnout alarm (HDA) conditions.
Level 2 Mode	This is the auxiliary mode for adjusting control. In this mode, you can set the parameters for limiting the manipulated variable, switch between the remote and local modes, and set the loop break alarm (LBA), alarm hysteresis, and the digital filter value of inputs.
Setup Mode	This is the mode for setting the basic specifications. In this mode, you can set parameters that must be checked or set before an operation such as the input type, scaling, output assignments, and direct/reverse operation.
Expansion Mode	This is the mode for setting expanded functions. In this mode, you can set SP setting limiter, switching between 2-PID control or ON/OFF control, program time unit, selection of step time/rate of rise, time unit of ramp rise rate, and the time for automatic return to the monitoring display.
Option Mode	This is the mode for setting optional functions. You can select this mode only when an Option Unit is mounted in the Controller. In this mode, you can set the communications conditions, transfer output and event input parameters to match the type of Option Unit mounted in the Controller. Heater burnout alarm function and position-proportional travel time are also found in this mode.
Calibration Mode	This mode is provided so that the user can calibrate inputs and output. When calibrating input, the selected input type is calibrated. Whereas, transfer output can be calibrated only when the Communications Unit (E53-AKF) is set in the Controller.

Parameter Operation

Refer to the *E5AK-T/E5EK-T/E5CK-T User's Manual (H88/H89/H90)* for each parameter and the calibration mode in detail.

Refer to page 135 for the setting in detail.

Level 0 Mode

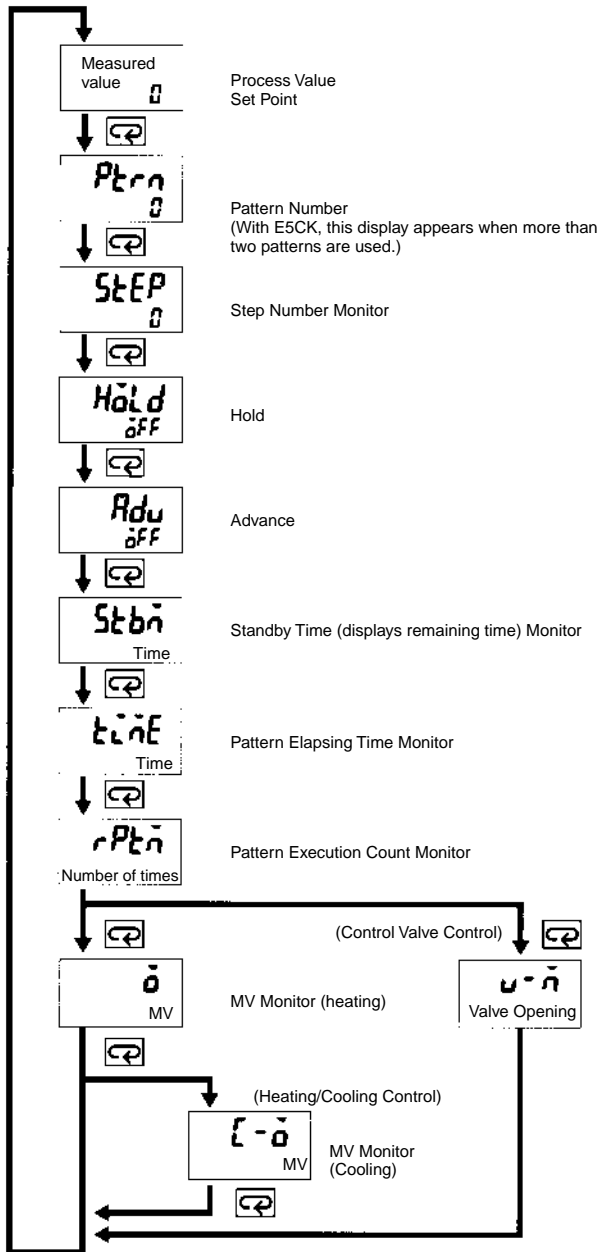

Protect Mode

Under this mode, key operations are invalidated for the Auto/Manual and Run/Reset.

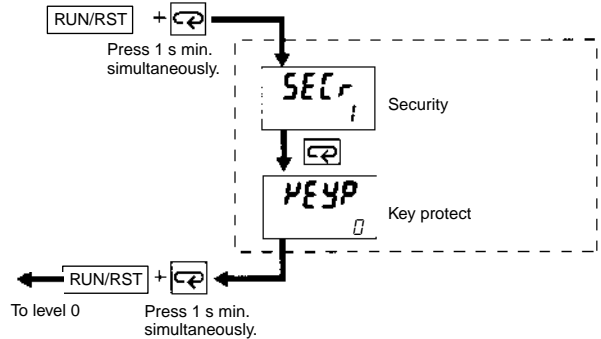

Security

Before starting operation, apply key protection to the parameters that will not be changed during operation in order to prevent any accidental parameter changes.

Depending on the set values for the Security parameter (protect mode), ranges of parameter application will be restricted. The following table shows relationship between the set values and the scope of protection.

Mode	Set value						
	0	1	2	3	4	5	6
Calibration	Yes	No	No	No	No	No	No
Option	Yes	Yes	No	No	No	No	No
Expansion	Yes	Yes	No	No	No	No	No
Setup	Yes	Yes	No	No	No	No	No
Level 2	Yes	Yes	Yes	No	No	No	No
Level 1, 0	Yes	Yes	Yes	Yes	No	No	No
Program	Yes	Yes	Yes	Yes	Yes	No	No
Level 0	Yes	Yes	Yes	Yes	Yes	Yes	*

Note: *Only the "Process Value/Set Point" parameter display is possible.

When the set value is "0," protection will not be applied.

When the set value is "5," only the parameter in the level 0 mode can be used and not possible to change to the menu screen.

When the set value is "6," only the "Process Value/Set Point" can be monitored.

The default setting is "1."

Manual Mode

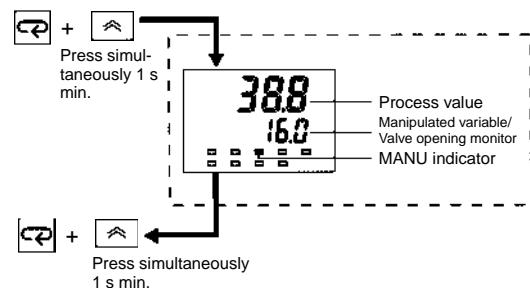

Program Mode

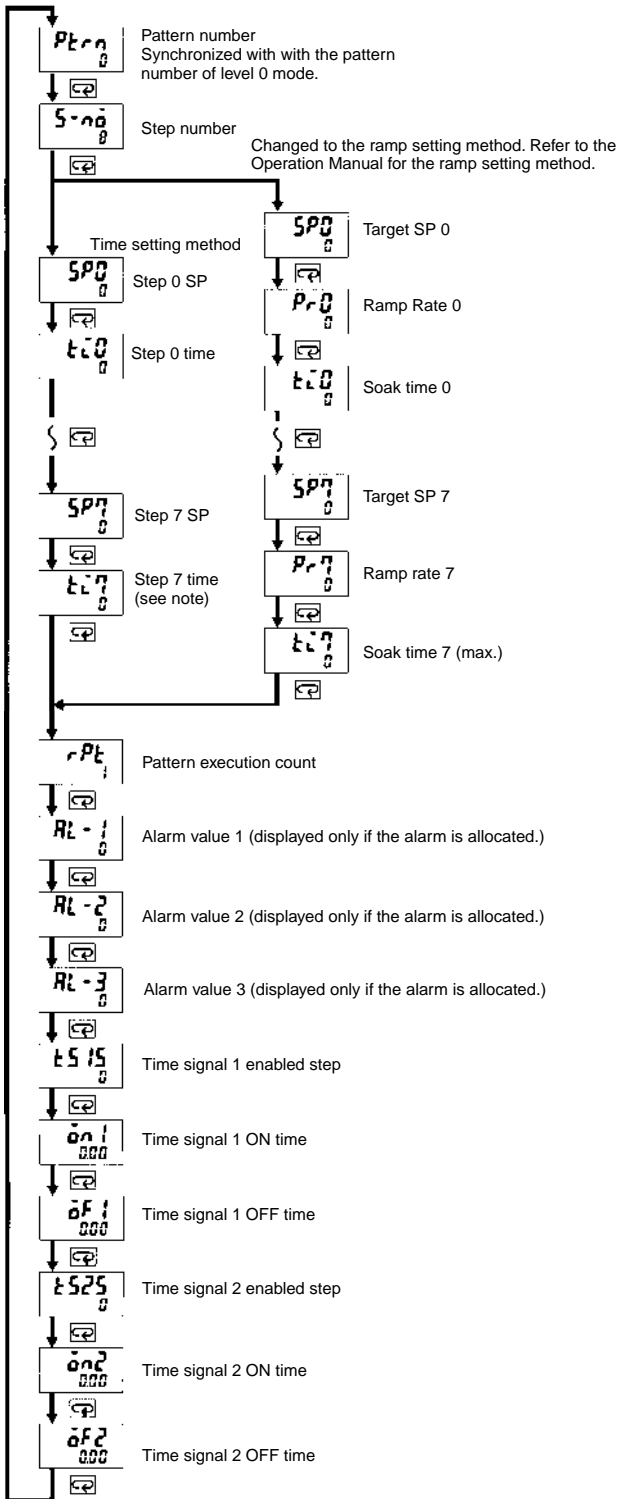

Time Setting Method

Set the number of steps to be used beginning with step 0 (e.g., step 0 SP, step 0 time, step 1 SP, and step 1 time).

The step target value can be set within a range between the lower and upper target value limits. The default value is zero.

The step time can be set within a range between 0.00 and 99.59 (in hr and min or min and s). The default value is 0.00.

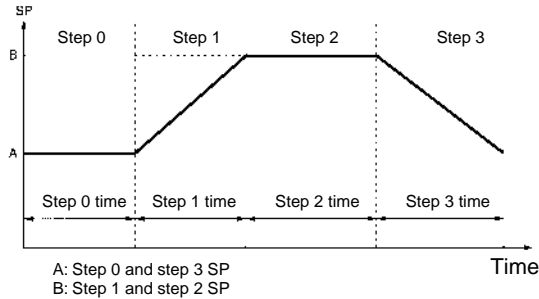

Step 0 is flat as shown in the above graph. Set step 0 to 0.00 so that step 1 will be the actual first step when writing ramp-start programs.

Note: Up to step 15 (i.e., a total of 16 steps) can be set in the time setting method.

Time Signal

Two types of time signal patterns can be set in each pattern.

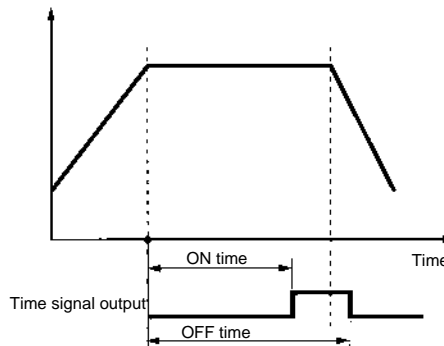

Two types of time signal timers are available (i.e., ON-time and OFF-time use), each of which starts with the edge of the step.

The output is ON from the moment the ON time elapses until the OFF time elapses.

Set the step so that the time signal is triggered by the time signal 1/2 enabled step parameters. The default is step 0.

Set the ON/OFF timing with the timing signal 1/2 ON-time and time signal 1/2 OFF-time parameters in Program mode.

ON Conditions

If the ON time is shorter than the OFF time, the signal will be reset or ON after the ON time elapses until the next pattern starts.

The signal is not ON if there is no difference in period between the ON time and OFF time.

If ADVANCE is executed while the time signal setting step is executed, the time equivalent to the setting step will be deemed to have elapsed. In the above graph, for example, the signal is ON from the edge of the next step until the OFF time elapses.

Level 1 Mode

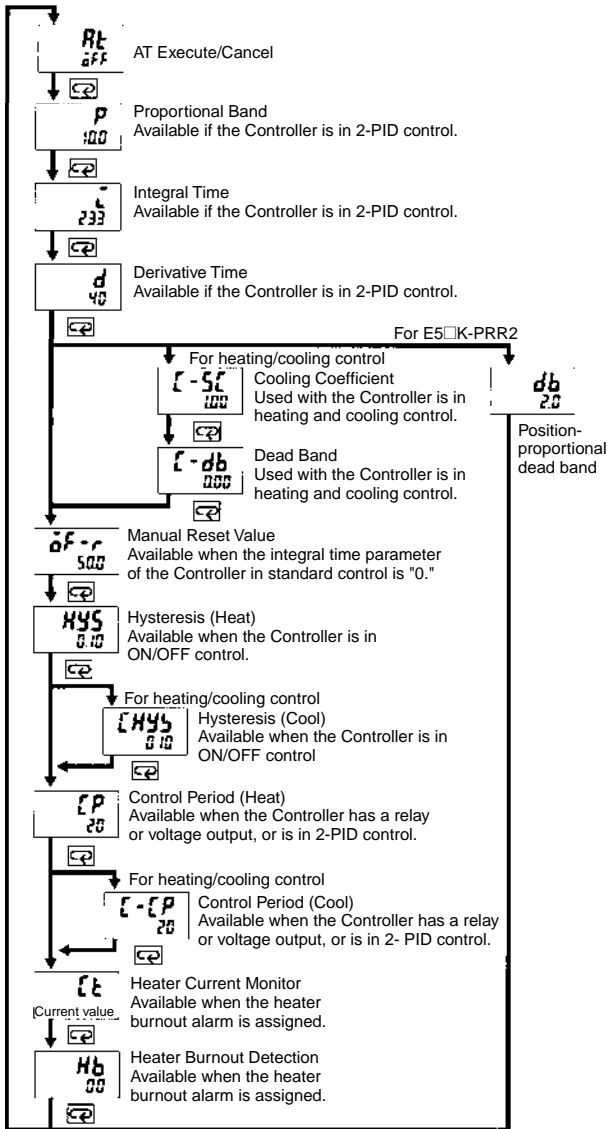

Level 2 Mode

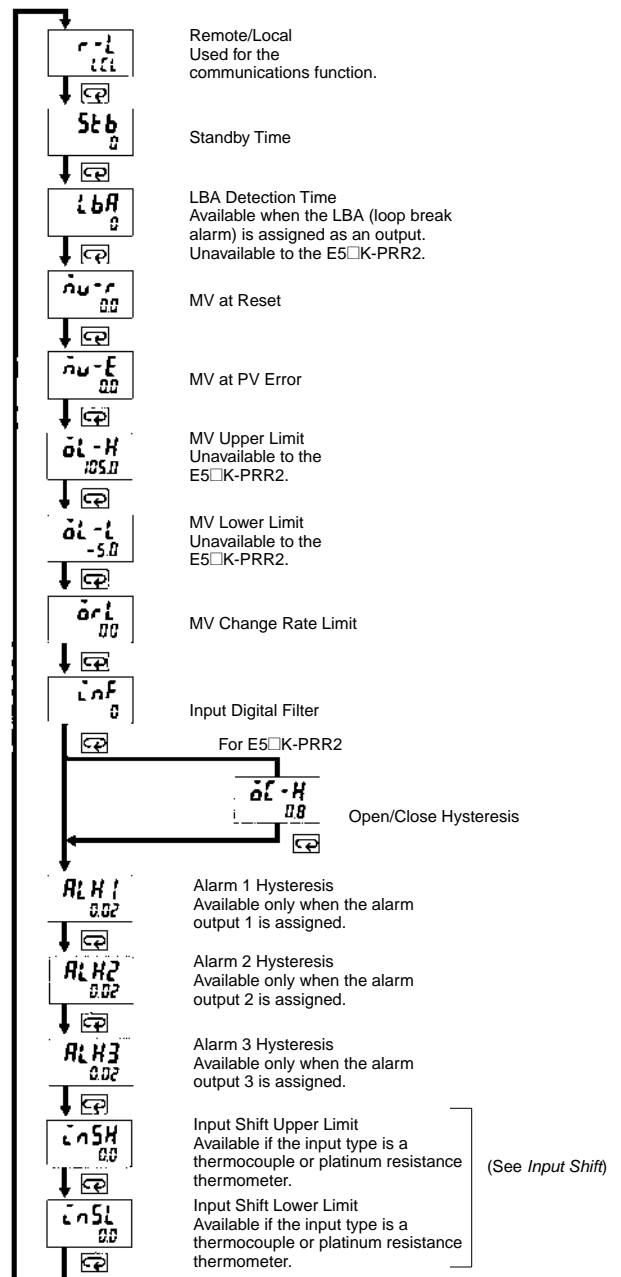

Input Shift

When temperature input is selected, scaling is not required. This is because input is treated as the "temperature" as it is matched to the input type. However, note that the upper- and lower-limit values of the sensor can be shifted. For example, if both the upper- and lower-limit values are shifted by 1.2°C, the process value (before shift) is regarded as 201.2°C after shift when input is 200°C before shift.

To set the input shift, set shift values in the "input shift upper limit" and "input shift lower limit" parameters (level 2 mode).

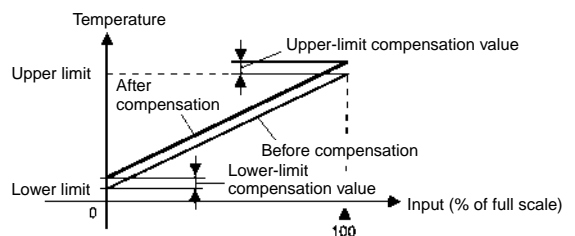

Expansion Mode

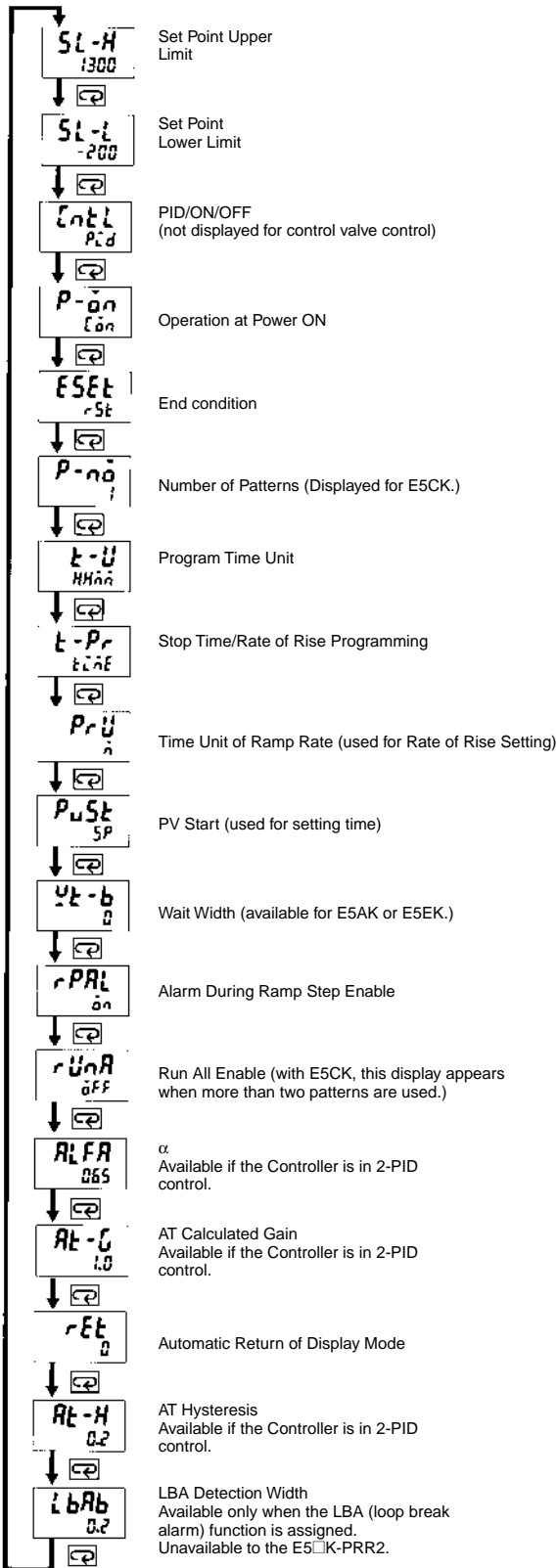

Option Mode

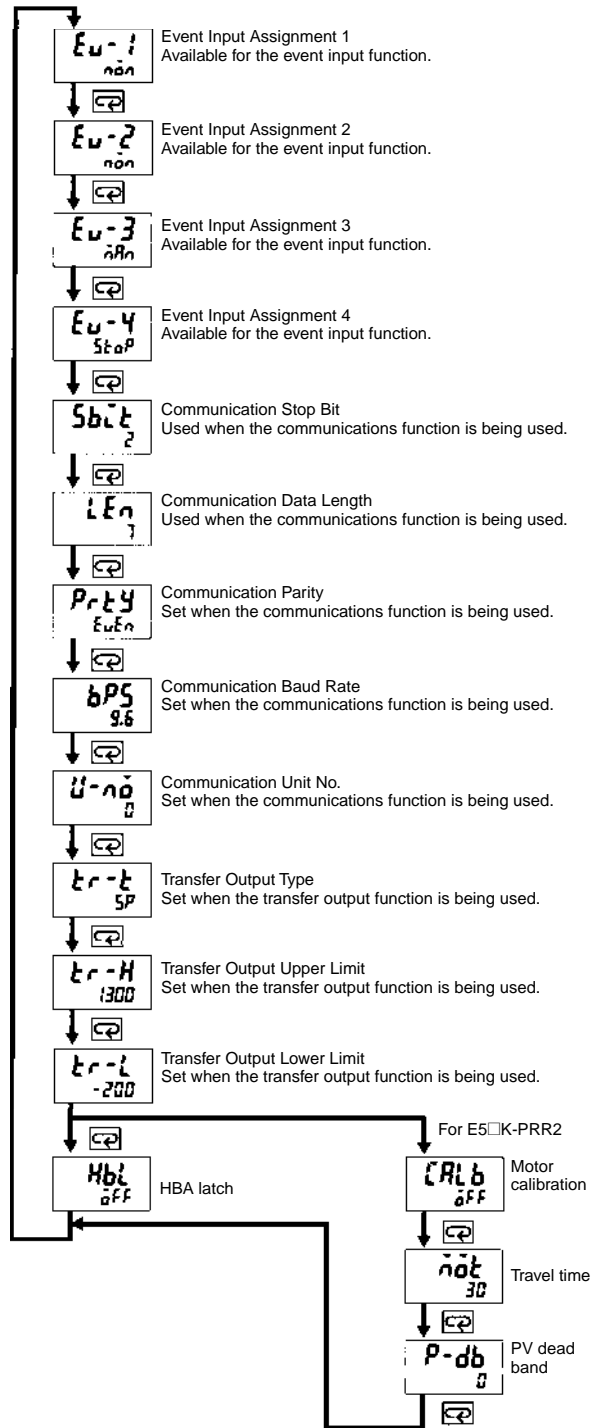

How to Use the Error Display

When an error has occurred, the No.1 display alternately indicates error codes together with the current display item. This section describes how to check error codes on the display, and the actions that must be taken to remedy the problem.

Input Error

- Meaning** Input is in error.
- Action** Check the wiring of inputs, disconnections, and shorts, and check the input type and the input type jumper connector.
- Operation at Error** For control output functions, output the manipulated variable matched to the setting of the "MV at PV error" parameter (level 2 mode). Alarm output functions are activated when the upper limit is exceeded.

Memory Error

- Meaning** Internal memory operation is in error
- Action** First, turn the power OFF then back ON again. If the display remains the same, the E5□K-T Controller must be repaired. If the display is restored to normal, the probable cause may be external noise affecting the control system. Check for external noise.
- Operation at Error** Control output functions turn OFF (2 mA max. at 4 to 20 mA output, and output equivalent to 0% in case of other outputs). Alarm output functions turn OFF.



A/D Converter Error

- Meaning** Internal circuits are in error.
- Action** First, turn the power OFF then back ON again. If the display remains the same, the E5□K-T Controller must be repaired. If the display is restored to normal, the probable cause may be external noise affecting the control system. Check for external noise.
- Operation at Error** Control output functions turn OFF (2 mA max. at 4 to 20 mA output, and output equivalent to 0% in case of other outputs). Alarm output functions turn OFF.

Calibration Data Error

- Meaning** This error is output only during temperature input and is displayed for two seconds when the power is turned ON. Calibration data is in error.
- Action** Must repair.
- Operation at Error** Both control output functions and alarm output functions are active. However, note that the readout accuracy is not assured.

Display Range Over

- Meaning** Though not an error, this is displayed when the process value exceeds the display range when the control range (setting range ±10%) is larger than the display range (-1999 to 9999).
 - When less than "-1999" 
 - When greater than "9999" 
- Operation** Control continues, allowing normal operation.

Peripheral Devices

■ SSR

Connection Example of Digital Controller and SSR

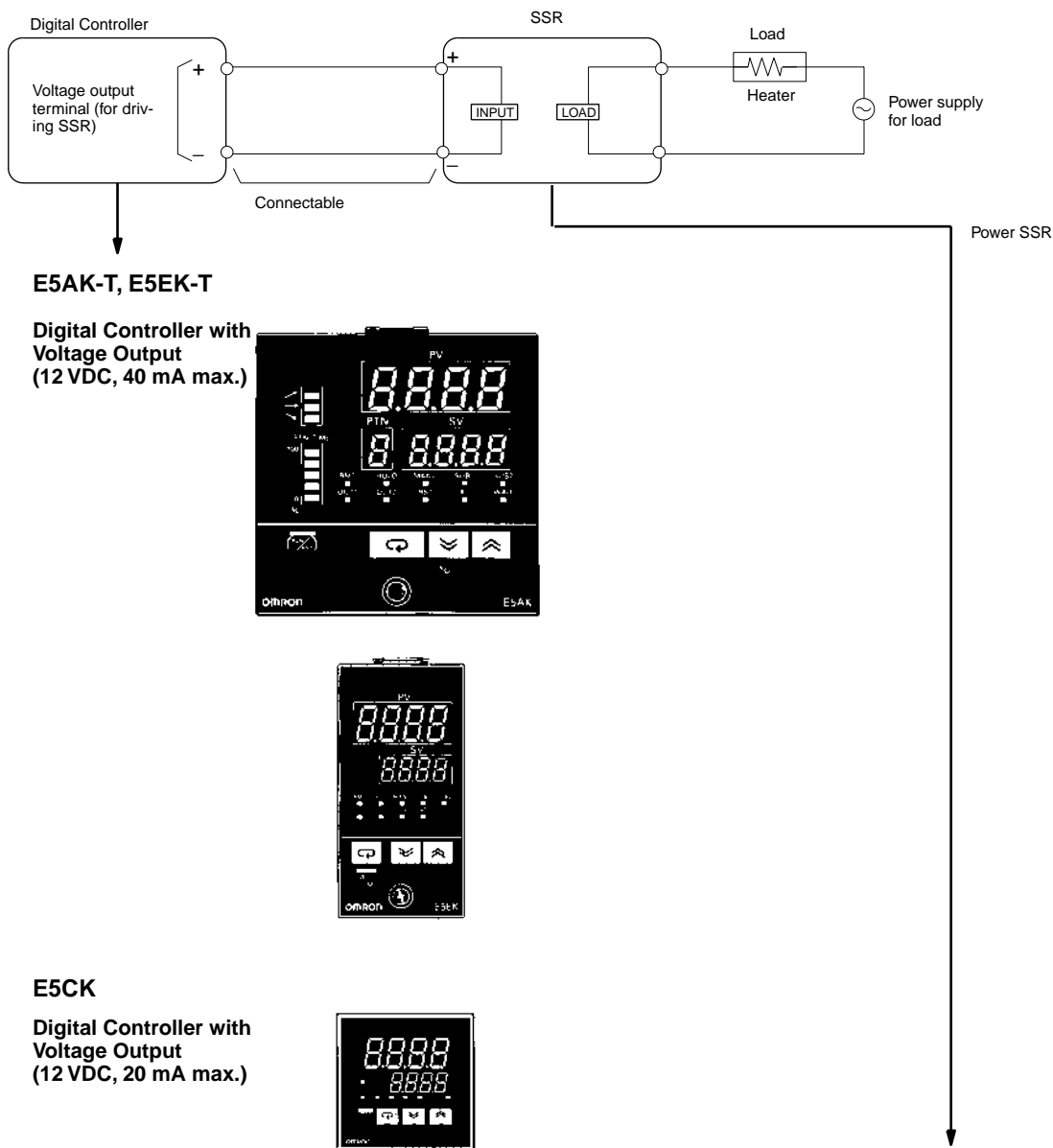

See the following table.

Model	G3PA	G3NH	G3NA	G3NE	G3B
Appearance					
SSRs connected in parallel	E5AK/E5EK: 5 pcs. E5CK: 3 pcs.	E5AK/E5EK: 8 pcs. E5CK: 4 pcs.	E5AK/E5EK: 5 pcs. E5CK: 2 pcs.	E5AK/E5EK: 2 pcs. E5CK: 1 piece	E5AK/E5EK: 5 pcs. E5CK: 2 pcs.
Rated input voltage	5 to 24 VDC	5 to 24 VDC	5 to 24 VDC	12 VDC	5 to 24 VDC
Features	Thin, monoblock construction with heat sink	For high-power heater control	Standard model with screw terminals	Compact, low-cost model with tab terminals	Socket, model with 5-A switching capacity

Precautions

⚠ WARNING

Do not touch any of the terminals while the power is being supplied.
Doing so may result in electric shock.

■ General Precautions

Be sure to observe these precautions to ensure safe use.

- Do not use the product in places where explosive or flammable gases may be present.
- Never disassemble, repair or modify the product.
- Tighten the terminal screws properly.
- Use the specified size of solderless terminals for wiring.
- Use the product within the rated supply voltage.
- Use the product within the rated load.
- The life expectancy of the output relay varies considerably according to its switching capacity and operating conditions. Be sure to use the output relay within its rated load and electrical life expectancy. If the output relay is used beyond its life expectancy, its contacts may become fused or burned.

■ Correct Use

If you remove the Controller from its case, never touch nor apply shock to the electronic parts inside.

Do not cover the E5□K-T. (Ensure sufficient space around the Controller to allow heat radiation.)

Do not use the Controller in the following places:

- Places subject to icing, condensation, dust, corrosive gas (especially sulfide gas or ammonia gas).
- Places subject vibration and large shocks.
- Places subject to splashing liquid or oil atmosphere.
- Places subject to intense temperature changes.
- Places subject to heat radiation from a furnace.

Be sure to wire properly with correct polarity of terminals.

When wiring input or output lines to the Controller, keep the following points in mind to reduce the influence from inductive noise:

- Allow adequate space between the high voltage/current power lines and the input/output lines.
- Avoid parallel or common wiring with high voltage sources and power lines carrying large currents.
- Using separating pipes, ducts, and shielded line is also useful in protecting the Controller, and its lines from inductive noise.

Cleaning: Do not use paint thinner or organic solvents. Use standard grade alcohol to clean the product.

Use a voltage (100 to 240 VAC at 50/60 Hz, or 24 VDC). At power ON, the prescribed voltage level must be attained within two seconds.

Allow as much space as possible between the Controller and devices that generate a powerful high frequency (high-frequency welders, high-frequency sewing machines, etc.) or surge. These devices may cause malfunctions.

If there is a large power-generating peripheral device and any of its lines near the Controller, attach a surge suppressor or noise filter to the device to stop the noise affecting the Controller system. In particular, motors, transformers, solenoids and magnetic coils have an inductance component, and therefore can generate very strong noise.

When mounting a noise filter on the power supply to the Controller, be sure to first check the filter's voltage and current capacity, and then mount the filter as close as possible to the Controller.

Use within the following temperature and humidity ranges:

- Temperature: -10°C to 55°C (with no icing or condensation)
 - Humidity: 35% to 85% (with no icing or condensation)
- If the Controller is installed inside a control board, the ambient temperature must be kept to under 55°C , including the temperature around the Controller.
If the Controller is subjected to heat radiation, use a fan to cool the surface of the Controller to under 55°C .

Store within the following temperature and humidity ranges:

- Temperature: -25°C to 65°C (with no icing or condensation)
- Humidity: 35% to 85% (with no icing or condensation)

Never place heavy objects on, or apply pressure to the Controller that may cause it to deform and deteriorate during use or storage.

Avoid using the Controller in places near a radio, television set, or wireless installing. These devices can cause radio disturbances which adversely affect the performance of the Controller.

Mounting

The dimensions of the Digital Controller conform to DIN 43700.

Recommended panel thickness is 1 to 8 mm (1 to 5 mm for E5CK).

Mount the Unit horizontally.

Connection

To reduce inductive noise influence, the lead wires connecting the input type to the Digital Controller must be separated from the power lines and load lines.

Use the specified compensating conductors for thermocouples. Use lead wires having a small resistance for platinum resistance thermometers.

Connection Example

Wire the terminals of the Unit using solderless terminals.

The tightening torque applied to the terminal screws of the Unit must be approximately 0.78 N·m or 8 kgf·cm.

Use the following type of solderless terminals for M3.5 screws.

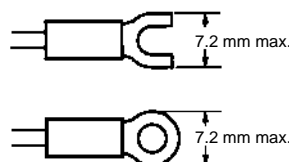

Ph: 03 5278 8222 Fax: 03 5278 9761
65 Douro Street, North Geelong VIC 3215
www.factorycontrols.com.au

ALL DIMENSIONS SHOWN ARE IN MILLIMETERS.

To convert millimeters into inches, multiply by 0.03937. To convert grams into ounces, multiply by 0.03527.