

# Ratchet Relay G4Q

## Unique Ratchet Mechanism Assures Positive Alternate Transfer/Switching Operation

- Each contact in the double-pole contact mechanism performs alternate make-brake operation at each pulse input and is thus ideal for alternate operation or transfer/switching operation of a motor.
- Positive operation is assured due to the unique ratchet mechanism.
- Satisfies dielectric strength of 2,000 VAC.
- Low power consumption.  
 (AC: approx. 6.4 VA; DC: approx. 3.9 W)

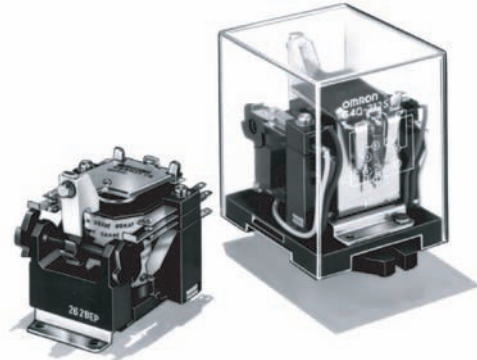

## Ordering Information

### Open Models

Item	DPDT	
	Rated voltage (V)	Model
Basic model	6 VAC	G4Q-211A
	12 VAC	
	24 VAC	
	50 VAC	
	100/(110) VAC	
	200/(220) VAC	
	6 VDC	
	12 VDC	
	24 VDC	
	48 VDC	
	100 VDC	
	200 VDC	

### Plug-in Models

Item	DPDT	
	Rated voltage (V)	Model
Basic model	6 VAC	G4Q-212S
	12 VAC	
	24 VAC	
	50 VAC	
	100/(110) VAC	
	200/(220) VAC	
	6 VDC	
	12 VDC	
	24 VDC	
	48 VDC	
	100 VDC	
	200 VDC	

**Note:** When ordering, add the rated coil voltage (listed in *Specifications*) to the model number.  
 Example: G4Q-211A, 24 VAC  
 \_\_\_\_\_ Rated coil voltage

## Model Number Legend

G4Q-□□□□  
 1 2 3 4

**1. Contact Form**

2: DPDT

**2. Contact Type**

1: Single

**3. Enclosure Construction**

- 1: No casing
- 2: Casing

**4. Terminal Shape**

- A: Solder
- S: Plug-in

## ■ Accessories (Order Separately)

DIN track/Front-connecting Socket	Back-connecting Socket
Screw terminal	Solder terminal
8PFA1	PL08

## Specifications

### ■ Coil Ratings

Item	Current (mA)		Resistance ( $\Omega$ )	Must operate	Must release	Max. voltage	Power consumption	
	Rated voltage (V)	50 Hz					60 Hz	Initial
AC	6	1,233	1,067	80 % max.	10 % min.	110 % max.	Approx. 13.5 VA	Approx. 6.4 VA
	12	614	531					
	24	307	266					
	50	148	128					
	100/ (110)	74	64/73.5					
	200/ (220)	37	32/36.8					

Item	Current (mA)		Resistance ( $\Omega$ )	Must operate	Must release	Max. voltage	Power consumption	
	Rated voltage (V)	50 Hz					60 Hz	Initial
DC	6	640	9.4	5 % min.			Approx. 3.9 W	
	12	320	37.5					
	24	155	155					
	48	80	600					
	100	39	2,580					
	200	19.2	10,400					

- Note:**
1. The rated current and coil resistance are measured at a coil temperature of 23°C with tolerances of +15%/–20% for AC rated current and  $\pm 15\%$  for DC coil resistance.
  2. The AC coil resistance values are for reference only.
  3. Performance characteristic data is measured at a coil temperature of 23°C.
  4. The maximum voltage is one that is applicable instantaneously to the Relay coil at an ambient temperature of 23°C and not continuously.
  5. The AC power consumption is measured at 60 Hz.

### ■ Contact Ratings

Load	Resistive load ( $\cos\phi = 1$ )	Inductive load ( $\cos\phi = 0.4$ ) (L/R = 7 ms)
Contact mechanism	Single	
Contact material	Silver alloy	
Rated load	5 A at 220 VAC, 5 A at 24 VDC	3 A at 220 VAC, 4 A at 24 VDC
Rated carry current	5 A	
Max. switching voltage	250 VAC, 250 VDC	
Max. switching current	5 A	

## ■ Characteristics

<b>Contact resistance (See note 2.)</b>	50 mΩ max.
<b>Operate time (See note 3.)</b>	60 ms max.
<b>Max. operating frequency</b>	Mechanical: 1,200 operations/hr Electrical: 1,200 operations/hr (under rated load)
<b>Insulation resistance (See note 4.)</b>	100 MΩ min. (at 500 VDC)
<b>Dielectric strength</b>	2,000 VAC, 50/60 Hz for 1 min between coil and contact (1,000 VAC, 50/60 Hz for 1 min between contacts of same polarity) (2,000 VAC between contacts of different polarities)
<b>Vibration resistance</b>	Destruction: 10 to 55 to 10 Hz, 0.75 mm single amplitude (1.5 mm double amplitude) Malfunction: 10 to 55 to 10 Hz, 0.5 mm single amplitude (1.0 mm double amplitude)
<b>Shock resistance</b>	Destruction: 500 m/s <sup>2</sup> Malfunction: 100 m/s <sup>2</sup>
<b>Endurance</b>	Mechanical: 5,000,000 operations min. (at operating frequency of 1,200 operations/hr) Electrical: 500,000 operations min. (under rated load and at operating frequency of 1,200 operations/hr) (See note 5.)
<b>Error rate (See note 6.)</b>	1 A at 5 VDC (0.1 A at 5 VDC)
<b>Ambient temperature</b>	Operating: -10°C to 55°C (with no icing or no condensation)
<b>Ambient humidity</b>	Operating: 5% to 85%
<b>Weight</b>	Open model: Approx. 240 g; cased model: Approx. 340 g

- Note:**
- The data shown above are initial values.
  - The contact resistance was measured with 0.1 A at 5 VDC using the voltage drop method.
  - The operate time was measured with the rated voltage imposed with any contact bounce ignored at an ambient temperature of 23°C.
  - The insulation resistance was measured with a 500-VDC megger applied to the same places as those used for checking the dielectric strength.
  - The electrical endurance was measured at an ambient temperature of 23°C.
  - This value was measured at a switching frequency of 60 operations per minute. The value in parentheses is for the cased model.

## Engineering Data

### Maximum Switching Power

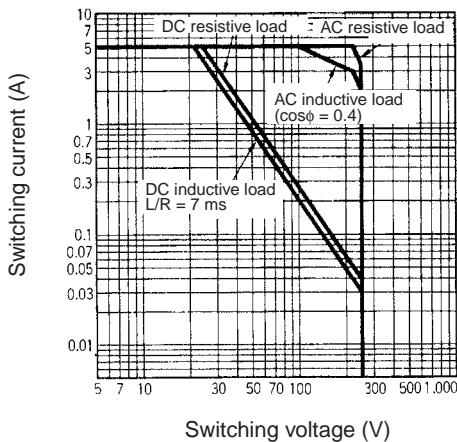

### Electrical Endurance

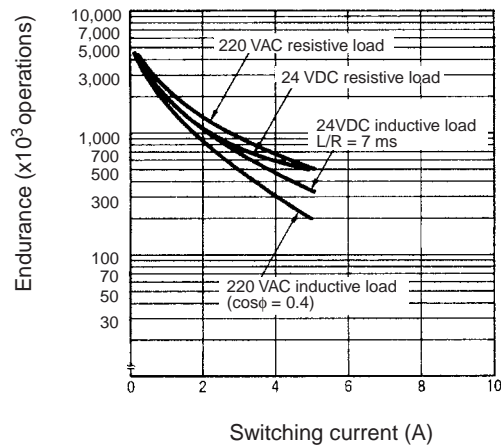

**Ambient Temperature vs. Coil Temperature Rise**  
100 VAC 50 Hz

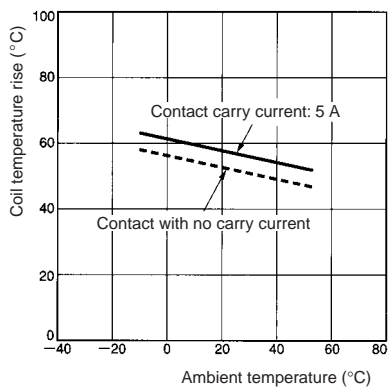

**24 VDC**

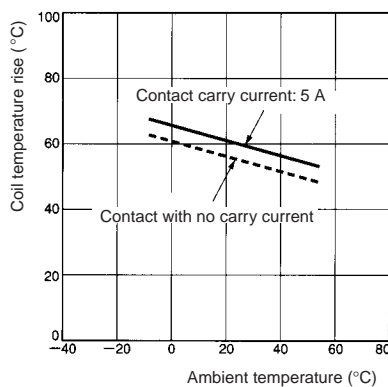

**Malfunctioning Shock**

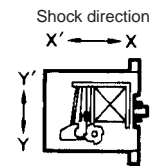
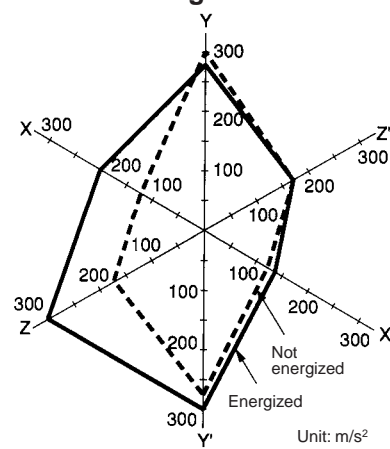

Number of samples: 5  
Measurement conditions:  
Impose a shock of 100 m/s<sup>2</sup> in the ±X, ±Y, and ±Z directions three times each with the Relay energized and not energized to check the shock values that cause the Relay to malfunction.

**Operation**

**Operation Timing Chart**

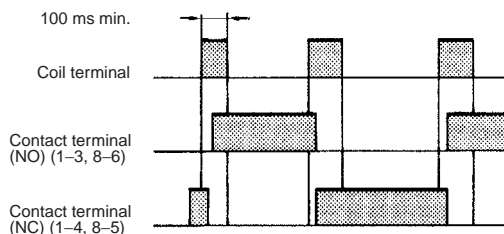

**Note:** When a pulse for application to the coil is used, such a pulse should have a width of 100 ms or more. If a pulse is applied with a width less than the operate time, the cam may fail to rotate fully.

**Dimensions**

**Note:** All units are in millimeters unless otherwise indicated.

**Open Model**  
G4Q-211A

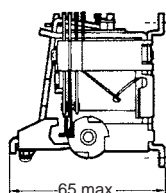
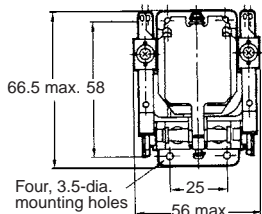
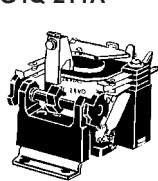

**Terminal Arrangement/ Internal Connections**

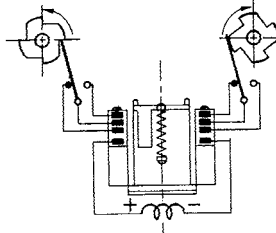

**Mounting Holes**

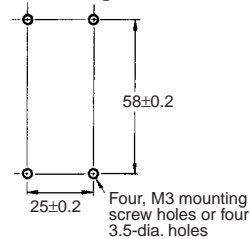

**Plug-in Terminal Model**  
G4Q-212S

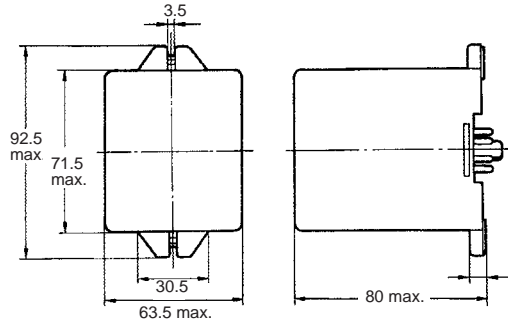
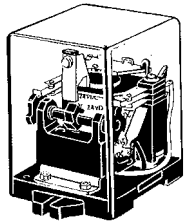

**Terminal Arrangement/  
Internal Connections**  
(Bottom view)

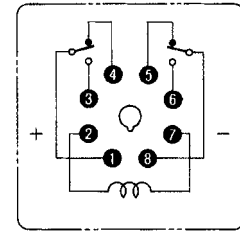

**Relay Mounting Height with Socket**

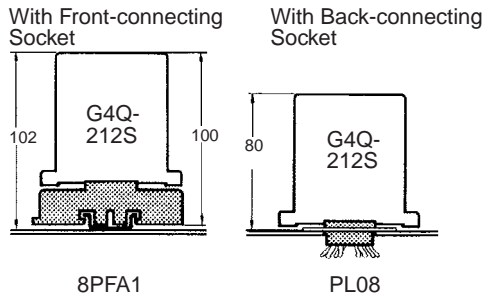

**Precautions**

Refer to page 11 for general precautions.

**■ Surface Mounting Socket**

Be sure to provide a mounting space according to the width of the Relay. The width of the Relay is 63.5 mm and the width of the Socket is 51 mm.

**■ Mounting**

Mount the Relay so that the coil faces upward and the cam faces downwards with the mounting plate secured vertically. Do not change the cam angle.

Make sure that Relay terminals are free of flux or any other foreign substance before soldering the Relay terminals.

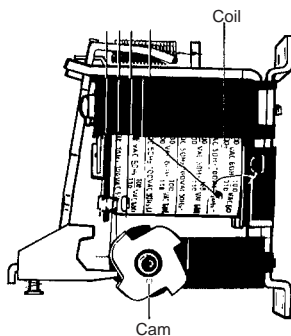

Ph: 03 5278 8222 Fax: 03 5278 9761  
65 Douro Street, North Geelong VIC 3215  
[www.factorycontrols.com.au](http://www.factorycontrols.com.au)

ALL DIMENSIONS SHOWN ARE IN MILLIMETERS.  
To convert millimeters into inches, multiply by 0.03937. To convert grams into ounces, multiply by 0.03527.