

Solid-state Timer H3DE

DIN Track Mounted, Standard 22.5-mm Width Timer Range

- A wide AC/DC power supply range (24 to 230 VAC/DC) reduces the number of timer models kept in stock. (except for H3DE-H)
- 12-VDC model available for a specific application. (H3DE-M2)
- Nameplate provided for easy timer identification and management.
- Terminal clamp left open when delivered.
- Finger protection terminal block to meet VDE0106/P100.
- Enables easy sequence checks through instantaneous outputs for a zero set value at any time range.
- Incorporates environment-friendly, cadmium-free contacts. (except for H3DE-H)
- High immunity to inverter noise.
- Approved by UL and CSA.
- Conforms to EN61812-1 and IEC60664-1 4 kV/2 for Low Voltage, and EMC Directives.

■ Broad Line-up of H3DE Series

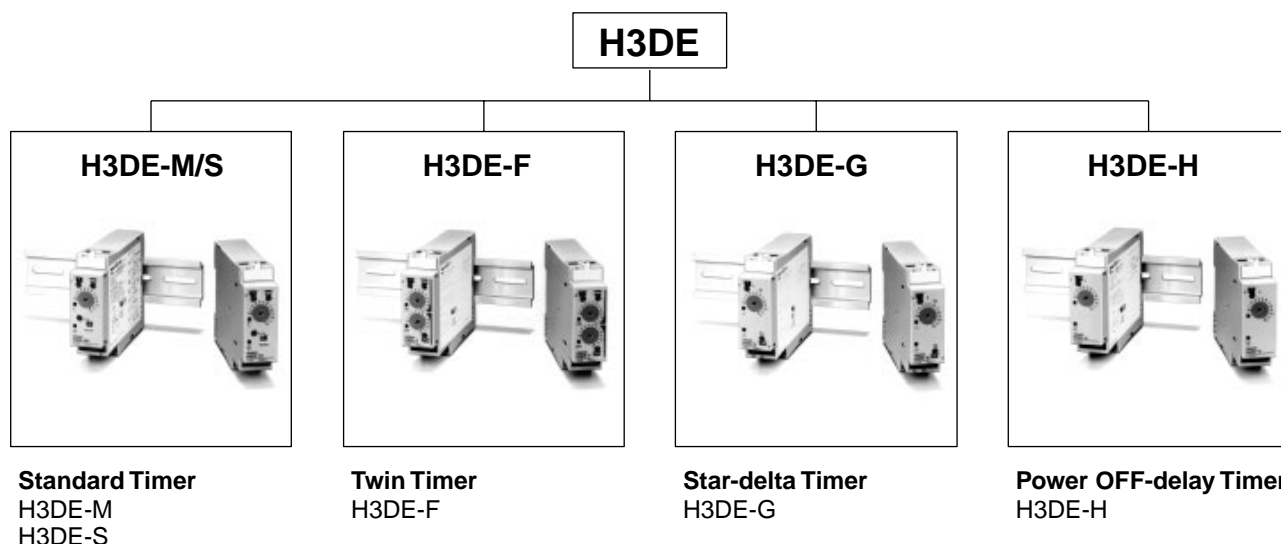

Contents

Solid-state Timer

H3DE-M/-S.....	B-55
H3DE-F	B-65
H3DE-G	B-71
H3DE-H.....	B-77

Common to ALL Timers

Accessories.....	B-83
Precautions	B-84

Solid-state Multi-functional Timer H3DE-M/-S

- Eight operating modes (H3DE-M) and four operating modes (H3DE-S) cover a wide range of applications.
- Programmable contact enables the building of a self-holding relay circuit (-□2 models).
- A wide time setting range of 0.10 s to 120 h.



Model Number Structure

Model Number Legend

H3DE - □ □
 1 2

- 1. M: Multi-function type
 S: Standard type
- 2. 2: DPDT
 1: SPDT

Ordering Information

List of Models

Supply voltage	Control output	Model	
		Multi-function type	Standard type
12 VDC	Contact output: DPDT (time-limit output SPDT and switchable SPDT (time-limit ↔ instantaneous))	H3DE-M2 (see note)	---
24 to 230 VAC/DC	Contact output: DPDT (time-limit output SPDT and switchable SPDT (time-limit ↔ instantaneous))	H3DE-M2 (see note)	H3DE-S2
	Contact output: SPDT (time-limit output SPDT)	H3DE-M1	H3DE-S1

Note: Specify both the model number and supply voltage when ordering H3DE-M2.
Example: H3DE-M2 24 to 230 VAC/DC

└── Supply voltage

Accessories (Order Separately)

Mounting Track	50 cm (l) x 7.3 mm (t)	PFP-50N
	1 m (l) x 7.3 mm (t)	PFP-100N
	1 m (l) x 16 mm (t)	PFP-100N2
End Plate	PFP-M	
Spacer	PFP-S	

Specifications

■ General

Item	H3DE-M2	H3DE-M1	H3DE-S2	H3DE-S1
Operating mode	A: ON-delay (Signal or Power) B: Flicker OFF start (Signal or Power) B2: Flicker ON start (Signal or Power) C: Signal ON/OFF-delay D: Signal OFF-delay E: Interval (Signal or Power) G: Signal ON/OFF-delay J: One-shot (Signal or Power)		A: ON-delay B2: Flicker ON start E: Interval J: One-shot	
Terminal block	Clamps two 2.5 mm ² max. bar terminals without sleeves.			
Terminal screw tightening torque	0.98 N·m max. {approx. 10 kgf·cm max.}			
Input type	Voltage input		---	
Output type	Relay: DPDT	Relay: SPDT	Relay: DPDT	Relay: SPDT
Mounting method	DIN track mounting (see note)			
Attachment	Nameplate			
Approved standards	UL508, CSA 22.2 No.14 Conforms to EN61812-1, IEC60664-1 4 kV/2, VDE0106/P100 Output category according to IEC60947-5-1 (AC-13; 250 V 5A/AC-15; 250 V 3 A/DC-13; 30 V 0.1 A)			

Note: Can be mounted to 35-mm DIN track with a plate thickness of 1 to 2.5 mm.

■ Time Ranges

Time scale display	Time unit display			
	sec	min	hrs	10 h
x 0.1	0.1 to 1.2 s	0.1 to 1.2 min	0.1 to 1.2 h	1 to 12 h
x 1	1 to 12 s	1 to 12 min	1 to 12 h	10 to 120 h

Note: When the main dial is set to "0" for all settings, the output will operate instantaneously.

■ Ratings

Rated supply voltage (see notes 1 and 2)	24 to 230 VAC/DC (50/60 Hz) 12 VDC (H3DE-M2 model only)	
Operating voltage range	85% to 110% of rated supply voltage	
Power reset	Minimum power-off time: 0.1 s	
Reset voltage	2.4 VAC/DC max.	
Power consumption (see note 3)	H3DE-M1	AC: approx. 4.3 VA (2.2 W) at 230 VAC DC: approx. 0.7 W at 24 VDC
	H3DE-M2	AC: approx. 4.8 VA (2.4 W) at 230 VAC DC: approx. 1.0 W at 24 VDC
	H3DE-S1	AC: approx. 2.7 VA (1.6 W) at 230 VAC DC: approx. 0.7 W at 24 VDC
	H3DE-S2	AC: approx. 3.2 VA (1.9 W) at 230 VAC DC: approx. 1.0 W at 24 VDC
Voltage input	Max. permissible capacitance between input lines (terminals B1 and A2): 2000 pF Load connectable in parallel with inputs (terminals B1 and A2) H-level: 20.4 to 253 VAC/DC L-level: 0 to 2.4 VAC/DC	
Control output	Contact output: 5 A at 250 VAC with resistive load ($\cos\phi = 1$) 5 A at 30 VDC with resistive load ($\cos\phi = 1$)	
Ambient temperature	Operating: -10°C to 55°C (with no icing) Storage: -25°C to 65°C (with no icing)	
Ambient humidity	Operating: 35% to 85%	

Note: 1. DC ripple rate: 20% max.

- Since an inrush current of 0.25 A will occur when using the power supply voltage at 24 VDC, pay careful attention when turning on or off the power supply to the Timer with a solid-state output such as a sensor.
- The power consumption is for mode A after the Timer counts the time-up time and for the AC input at 50 Hz. The power consumption of the H3DE-M□ includes the input circuit with the B1 and A1 terminals short-circuited.

■ Characteristics

Accuracy of operating time	±1% max. of FS (±1% ±10 ms max. at 1.2-s range) (see note 1)	
Setting error	±10% ±50 ms max. of FS (see note 1)	
Signal input time	50 ms min. (see note 1)	
Influence of voltage	±0.5% max. of FS (±0.5% ±10 ms max. at 1.2-s range)	
Influence of temperature	±2% max. of FS (±2%±10 ms max. at 1.2-s range)	
Insulation resistance	100 MΩ min. at 500 VDC	
Dielectric strength	Between current-carrying metal parts and exposed non-current-carrying metal parts: 2,000 VAC for 1 min. Between control output terminals and operating circuit: 2,000 VAC for 1 min. Between contacts of different polarities: 2,000 VAC for 1 min. Between contacts not located next to each other: 1,000 VAC for 1 min.	
Vibration resistance	Malfunction: 0.5-mm single amplitude at 10 to 55 Hz Destruction: 0.75-mm single amplitude at 10 to 55 Hz	
Shock resistance	Malfunction: 100 m/s ² Destruction: 1,000 m/s ²	
Contact material	AGNi+gold plating (Use the G6RN-1 at 12 VDC.)	
Impulse withstand voltage	3 kV (between power terminals) 4.5 kV (between current-carrying metal parts and exposed non-current-carrying metal parts)	
Noise immunity	Square-wave noise generated by noise simulator (pulse width: 100 ns/1 μs, 1-ns rise) ±1.5 kV	
Static immunity	Malfunction: 4 kV Destruction: 8 kV	
Life expectancy	Mechanical: 10 million operations min. (under no load at 1,800 operations/h) Electrical: 100,000 operations min. (5 A at 250 VAC, resistive load at 360 operations/h) (see note 2)	
EMC	(EMI)	EN61812-1
	Emission Enclosure:	EN55011 Group 1 class B
	Emission AC Mains:	EN55011 Group 1 class B
	Harmonic Current:	EN61000-3-2
	Voltage Fluctuation and Flickering:	EN61000-3-3
	(EMS)	EN61812-1
	Immunity ESD:	EN61000-4-2: 6 kV contact discharge (level 3) 8 kV air discharge (level 3)
	Immunity RF-interference from AM Radio Waves:	EN61000-4-3: 10 V/m (80 MHz to 1 GHz) (level 3)
	Immunity Burst:	EN61000-4-4: 2 kV power port and output port (level 3) 1 kV control port with capacitive clamp (level 3)
	Immunity Surge:	EN61000-4-5: 2 kV common mode (level 3) 1 kV differential mode (level 3)
Degree of protection	IP30 (Terminal block: IP20)	
Weight	120 g	

Note: 1. With the H3DE-M□, if the voltage exceeds 26.4 VAC/DC, the following hold at signal OFF for C, D, and G modes:

Accuracy of operating time: ±1% ±50 ms max. at 1.2-s range
Setting error: ±10% +100/-50 ms max.
Signal input time: 100 ms min.

2. For reference: A maximum current of 0.15 A can be switched at 125 VDC (cosφ=1).
A maximum current of 0.1 A can be switched if L/R is 7 ms.
In both cases, a life of 100,000 operations can be expected.
The minimum applicable load is 10 mA at 5 VDC (failure level: P).

Connections

■ Block Diagram

H3DE-M1/-M2

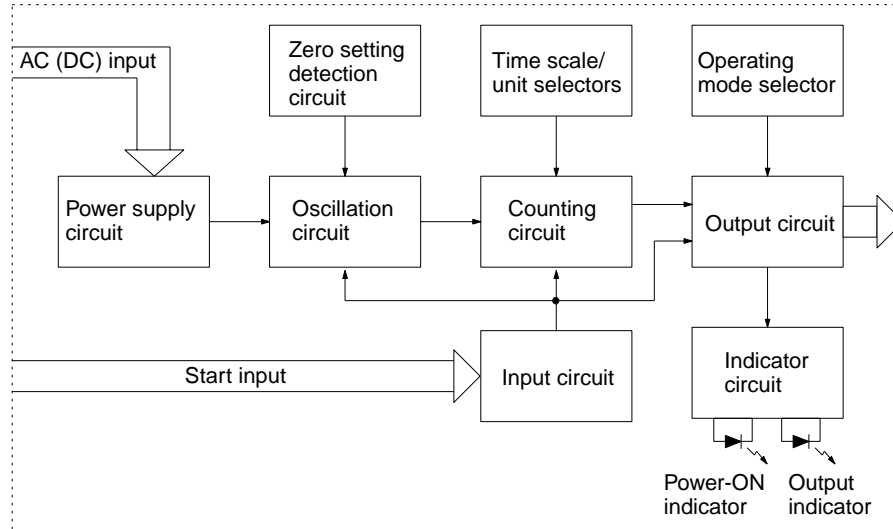

H3DE-S1/-S2

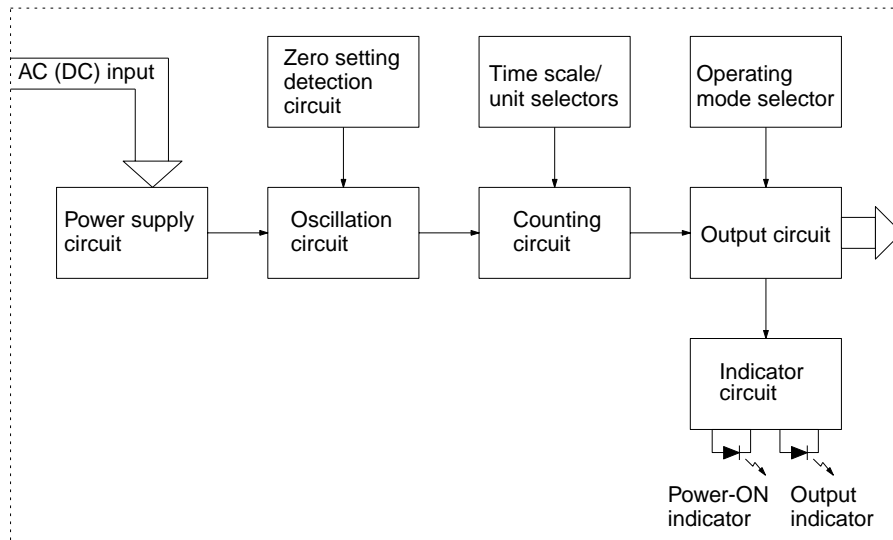

■ I/O Functions

Item		H3DE-M1/-M2	H3DE-S1/-S2
Input	Start	Starts operation.	No input is available.
Output	Control output	Outputs are turned ON according to designated output mode when preset value is reached. (See note.)	Outputs are turned ON according to designated output mode when preset value is reached. (see note.)

Note: When the output type selector switch on the bottom of the Timer is set to the instantaneous side, the relay R2 (terminal numbers 21/25, 22/26, and 24/28) becomes an instantaneous contact and turns ON/OFF in synchronization with the changes in the power supply.

Terminal Arrangement

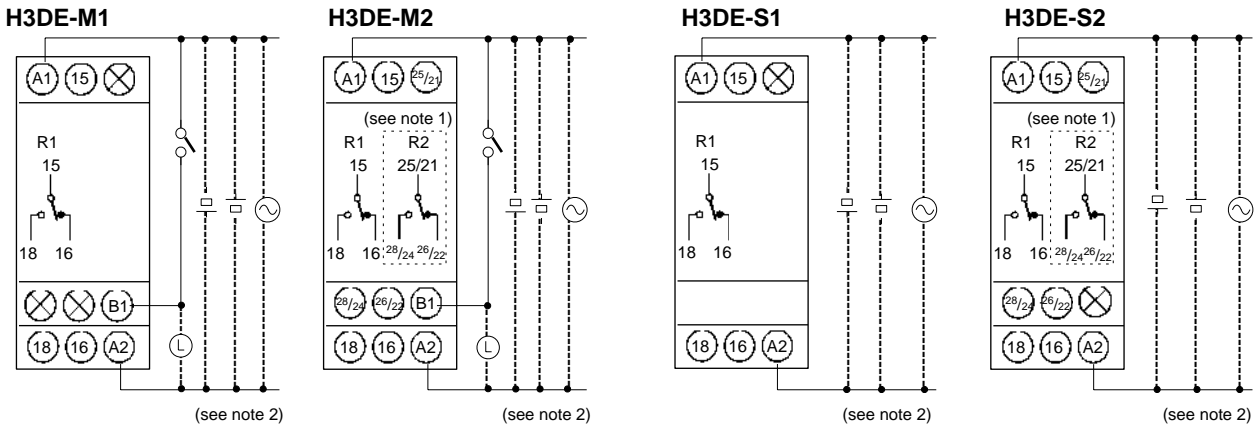

(DIN notation)

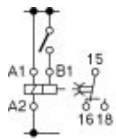

(DIN notation)

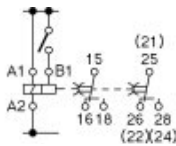

(DIN notation)

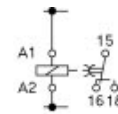

(DIN notation)

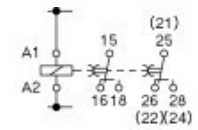

- Note:** 1. The relay R2 can be set to either instantaneous or time-limit contact using the switch located on the bottom of the Timer.
 2. DC supply voltage does not require the designation of polarity.
 3. The contact symbol for the H3DE is indicated with  because it offers multiple operating modes and is different from the delayed contact for conventional timers.

Input Connections

The inputs of the H3DE-M1/M-2 are voltage (voltage imposition or open) inputs.

No-contact Input

(Connection to PNP output sensor.)

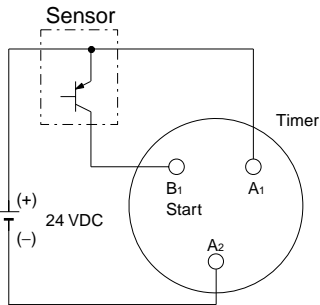

Operates with PNP transistor ON

No-contact Input

(Connection to NPN output sensor.)

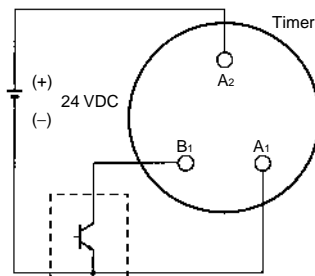

Operates with NPN transistor ON

Contact Input

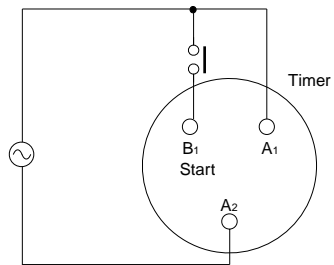

Operates with relay ON

Voltage Input Signal Levels

No-contact input	1. Transistor ON Residual voltage: 1 V max. (Voltage between terminals B1 and A2 must be more than the rated "H-level" voltage (20.4 VDC min.).)
	2. Transistor OFF Leakage current: 0.01 mA max. (Voltage between terminals B1 and A2 must be less than the rated "L-level" voltage (2.4 VDC max.).)
Contact input	Use contacts that can adequately switch 0.1 mA at each voltage to be imposed. (When the contacts are ON or OFF, voltage between terminals B1 and A2 must be within the following ranges: When contacts are ON: 20.4 to 253 VAC/DC When contacts are OFF: 0 to 2.4 VAC/DC

Operation

■ Basic Operation

Setting of Selector

The selectors can be turned clockwise and counterclockwise to select the desired time unit, time scale, or operating mode.

Each selector has a snap mechanism that secures the selector at a given position. Set the selector at a position at which it is secured. Do not set it midway between two securing positions or a malfunction could result from improper setting.

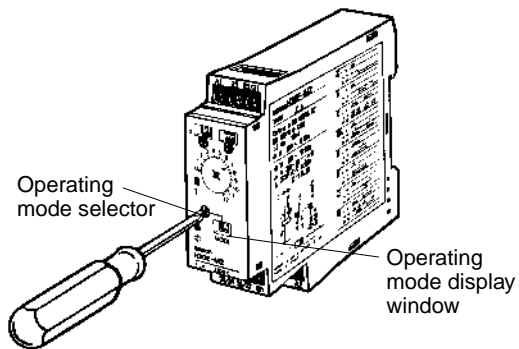

Selection of Operating Mode

The H3DE-M/-S can be set to any one of the operating modes A to J. Turn the operating mode selector with a screwdriver until the desired operating mode (A, B, C, B2, D, E, J, or G for the H3DE-M and A, E, J, or B2 for the H3DE-S) appears in the operating mode display window located below the selector.

Selection of Time Unit and Time Scale

The desired time unit (s, m, h, or 10h) can be displayed in the time unit display window above the time setting dial by turning the time unit selector located at the upper right corner of the front panel. Time scale (0.1 or 1) is selected with the time scale selector at the upper left corner of the front panel, it appears in the time scale display window above the selector.

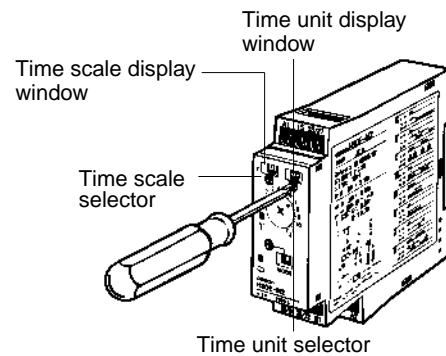

Timing Chart

- Note:**
1. The minimum power reset time is 0.1 s and the minimum signal input time is 0.05 s.
 2. The letter "t" in the timing charts stands for the set time and "t-a" means that the period is less than the time set.
 3. There is no start input with H3DE-S□ models. Operation starts when the power is turned ON.
 4. There is no instantaneous output with H3DE-M1/S1 models.

Operating mode	Timing chart	
A: ON-delay Power (A ₁ and A ₂) Start (B ₁ and A ₂) (see note) Time-limit contacts: NC 15 and 16 (25 and 26) Time-limit contacts: NO (output indicator) 15 and 18 (25 and 28) Instantaneous contacts: NC 25 and 26 Instantaneous contacts: NO 25 and 28 Power indicator		<p>Basic operation</p> <p>* For power-on operation, impose voltage to the Start input. The Timer starts operating at the moment the power is turned on. ** Start input is invalid while the Timer is in operation.</p>
B: Flicker OFF start Power (A ₁ and A ₂) Start (B ₁ and A ₂) (see note) Output relay: NC 15 and 16 (25 and 26) Output relay: NO (output indicator) 15 and 18 (25 and 28) Instantaneous contacts: NC 25 and 26 Instantaneous contacts: NO 25 and 28 Power indicator		<p>Basic operation</p> <p>* For power-on operation, impose voltage to the Start input. The Timer starts operating at the moment the power is turned on. ** Start input is invalid while the Timer is in operation.</p>
B2: Flicker ON start Power (A ₁ and A ₂) Start (B ₁ and A ₂) (see note) Output relay: NC 15 and 16 (25 and 26) Output relay: NO (output indicator) 15 and 18 (25 and 28) Instantaneous contacts: NC 25 and 26 Instantaneous contacts: NO 25 and 28 Power indicator		<p>Basic operation</p> <p>* For power-on operation, impose voltage to the Start input. The Timer starts operating at the moment the power is turned on. ** Start input is invalid while the Timer is in operation.</p>
C: Signal ON/OFF-delay Power (A ₁ and A ₂) Start (B ₁ and A ₂) (see note) Output relay: NC 15 and 16 (25 and 26) Output relay: NO (output indicator) 15 and 18 (25 and 28) Instantaneous contacts: NC 25 and 26 Instantaneous contacts: NO 25 and 28 Power indicator		<p>Basic operation</p> <p>* Start input is valid and re-triggerable while the Timer is in operation.</p>

Note: The start input of the H3DE-M1 or H3DE-M2 model is activated by applying a voltage to B1 and A2 terminals. The voltage can be applied by turning on the contact between B1 and A1 (Refer to *Terminal Arrangement*)

Operating mode	Timing chart	
D: Signal OFF-delay		<p>Basic operation</p> <p>* Start input is valid and re-triggerable while the Timer is in operation.</p>
E: Interval		<p>Basic operation</p> <p>* For power-on operation, impose voltage to the Start input. The Timer starts operating at the moment the power is turned on. ** Start input is valid and re-triggerable while the Timer is in operation.</p>
G: Signal ON/OFF-delay		<p>Basic operation</p> <p>* Start input is valid and re-triggerable while the Timer is in operation.</p>
J: One-shot output (ON delay)		<p>Basic operation</p> <p>* For power-on operation, impose voltage to the Start input. The Timer starts operating at the moment the power is turned on. ** Start input is valid and re-triggerable while the Timer is in operation.</p>

Note: The start input of the H3DE-M1 or H3DE-M2 model is activated by applying a voltage to B1 and A2 terminals. The voltage can be applied by turning on the contact between B1 and A1 (Refer to *Terminal Arrangement*).

Nomenclature

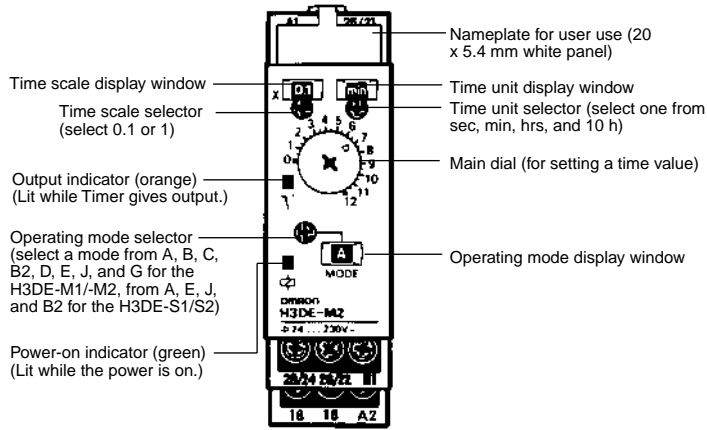

(Front View)

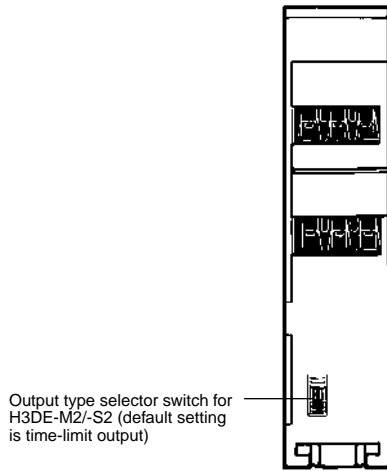

(Bottom View)

Output Type Selector Switch Settings

Setting	Output type
	Time-limit output (terminal numbers 25, 26 and 28) (default setting)
	Instantaneous output (terminal numbers 21, 22 and 24)

Dimensions

Note: All units are in millimeters unless otherwise indicated.

H3DE-M/-S

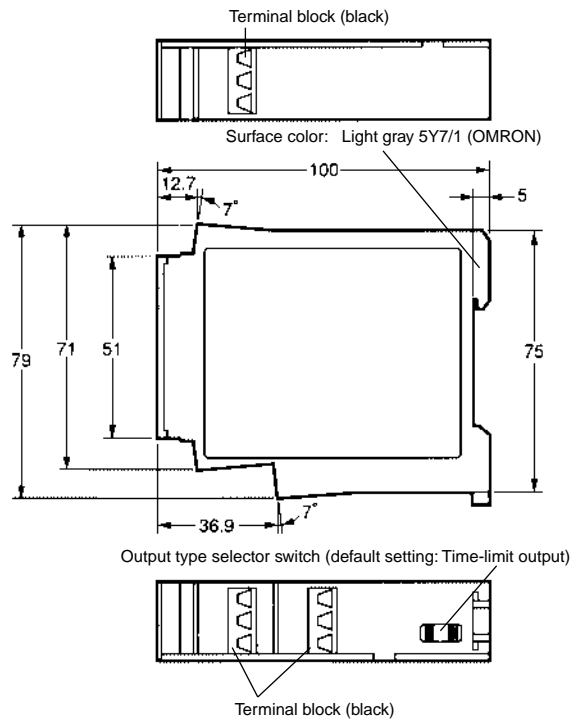
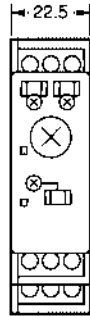
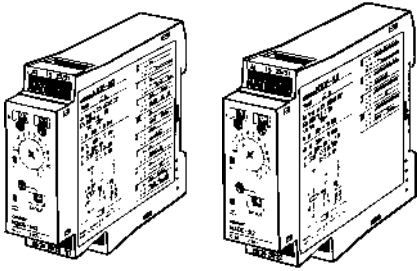

Solid-state Twin Timer H3DE-F

- Operates in flicker-OFF or flicker-ON start mode with one Unit.
- Independent ON- and OFF-time settings.
Combinations of long ON- or OFF-time and short OFF- or ON-time setting are possible.
- Long time range from 0.1 s to 12 h for both ON and OFF time settings.



Model Number Structure

■ Model Number Legend

H3DE -
1

1. F: Twin timers

Ordering Information

■ List of Models

Operating mode	Supply voltage	Model
Flicker-OFF/Flicker-ON start	24 to 230 VAC/VDC	H3DE-F

■ Accessories (Order Separately)

Mounting Track	50 cm (l) x 7.3 mm (t)	PFP-50N
	1 m (l) x 7.3 mm (t)	PFP-100N
	1 m (l) x 16 mm (t)	PFP-100N2
End Plate	PFP-M	
Spacer	PFP-S	

Specifications

■ General

Item	H3DE-F
Operating mode	Flicker-OFF/Flicker-ON start
Operating/Reset method	Time-limit operation/Time-limit reset or self-reset
Terminal block	Clamps two 2.5 mm ² max. bar terminals without sleeves
Terminal screw tightening torque	0.98 N·m max. {approx. 10 kgf·cm max.}
Output type	Relay: SPDT
Mounting method	DIN track mounting (see note)
Attachment	Nameplate
Approved standards	UL508, CSA 22.2 No.14 Conforms to EN61812-1, IEC60664-1 4 kV/2, VDE0106/P 100 Output category according to IEC60947-5-1 (AC-13; 250 V 5A/AC-15; 250 V 3 A/DC-13; 30 V 0.1 A)

Note: Can be mounted to 35-mm DIN track with a plate thickness of 1 to 2.5 mm.

■ Time Ranges

Time scale display (see note 1)	Time unit display			
	sec	10 s	min	hrs
x 0.1	0.1 to 1.2 s	1 to 12 s	0.1 to 1.2 min	0.1 to 1.2 h
x 1	1 to 12 s	10 to 120 s	1 to 12 min	1 to 12 h

- Note:** 1. Time scale display is applied commonly for ON and OFF time.
2. When the main dial is set to "0" for all settings, the output will operate instantaneously.

■ Ratings

Rated supply voltage (see note)	24 to 230 VAC/VDC (50/60 Hz)
Operating voltage range	85% to 110% of rated supply voltage
Power reset	Minimum power-off time: 0.1 s
Reset voltage	2.4 VAC/DC max.
Power consumption	AC: Approx. 3.1 VA (1.8 W) at 230 VAC DC: Approx. 0.8 W at 24 VDC
Control output	Contact output: 5 A at 250 VAC with resistive load ($\cos\phi = 1$) 5 A at 30 VDC with resistive load ($\cos\phi = 1$)
Ambient temperature	Operating: -10°C to 55°C (with no icing) Storage: -25°C to 65°C (with no icing)
Ambient humidity	Operating: 35% to 85%

Note: DC ripple rate: 20% max.

■ Characteristics

Accuracy of operating time	±1% max. of FS (±1% ±10 ms max. at 1.2-s range)
Setting error	±10% ± 0.05 s max. of FS
Influence of voltage	±0.5% max. of FS (±0.5% ±10 ms max. at 1.2-s range)
Influence of temperature	±2% max. of FS (±2% ± 10 ms max. at 1.2-s range)
Insulation resistance	100 MΩ min. at 500 VDC
Dielectric strength	Between current-carrying metal parts and exposed non-current-carrying metal parts: 2,000 VAC (50/60 Hz) for 1 min. Between control output terminals and operating circuit: 2,000 VAC (50/60 Hz) for 1 min. Between contacts not located next to each other: 1,000 VAC (50/60 Hz) for 1 min.
Impulse withstand voltage	3 kV (between power supply terminals) 4.5 kV (between current-carrying metal parts and exposed non-current-carrying metal parts)
Noise immunity	Square-wave noise generated by noise simulator (pulse width: 100 ns/1 μs, 1-ns rise) ±1.5 kV
Static immunity	Malfunction: 4 kV Destruction: 8 kV
Vibration resistance	Malfunction: 0.5-mm single amplitude at 10 to 55 Hz Destruction: 0.75-mm single amplitude at 10 to 55 Hz
Shock resistance	Malfunction: 100 m/s ² Destruction: 1,000 m/s ²
Life expectancy	Mechanical: 10 million operations min. (under no load at 1,800 operations/h) Electrical: 100,000 operations min. (5 A at 250 VAC, resistive load at 360 operations/h)
EMC	(EMI) EN61812-1 Emission Enclosure: EN55011 Group 1 class B Emission AC Mains: EN55011 Group 1 class B Harmonic Current: EN61000-3-2 Voltage Fluctuation and Flickering: EN61000-3-3 (EMS) EN61812-1 Immunity ESD: EN61000-4-2: 6 kV contact discharge (level 3) 8 kV air discharge (level 3) Immunity RF-interference from AM Radio Waves: EN61000-4-3: 10 V/m (80 MHz to 1 GHz) (level 3) Immunity Burst: EN61000-4-4: 2 kV power port and output port (level 3) 1 kV control port with capacitive clamp (level 3) Immunity Surge: EN61000-4-5: 2 kV common mode (level 3) 1 kV differential mode (level 3)
Degree of protection	IP30 (IP20 for terminal block)
Weight	Approx. 110 g

Note: For reference:

- A maximum current of 0.15 A can be switched at 125 VDC (cosφ=1).
- A maximum current of 0.1 A can be switched if L/R is 7 ms.
- In both cases, a life of 100,000 operations can be expected.
- The minimum applicable load is 10 mA at 5 VDC (failure level: P).

Connections

■ Block Diagram

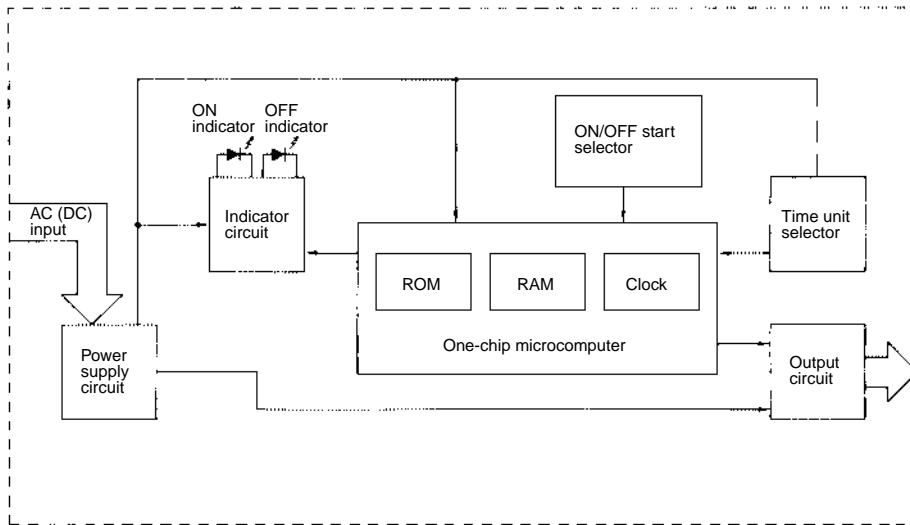

■ I/O Function

Inputs	---	
Outputs	Control output	Outputs are turned ON/OFF according to the time set by the ON-and OFF-time setting dial.

■ Terminal Arrangement

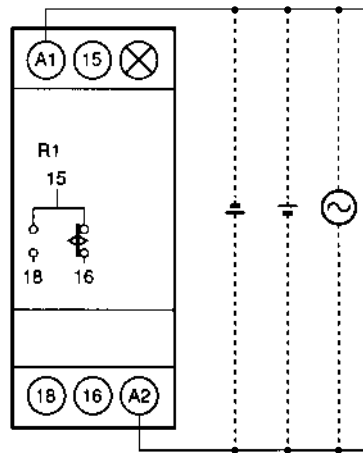

(DIN notation)

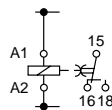

Note: DC supply voltage does not require the designation of polarity.

Operation

Basic Operation

Time Unit Selection

The time unit display window for output ON is located on the upper-right side of the front panel above the corresponding time unit selector.

The time unit display window for output OFF is located on the lower-right side of the front panel below the corresponding time unit selector.

According to the setting of each time unit selector, "sec" for seconds, "10s" for 10 seconds, "min" for minutes, or "hrs" for hours will appear in the corresponding time unit display window.

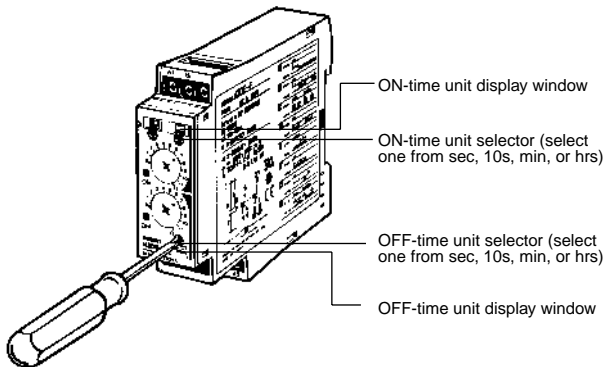

Time Scale Selection

The time scale selector on the upper-left side of the front panel can be set to 0.1 or 1 as a magnification coefficient.

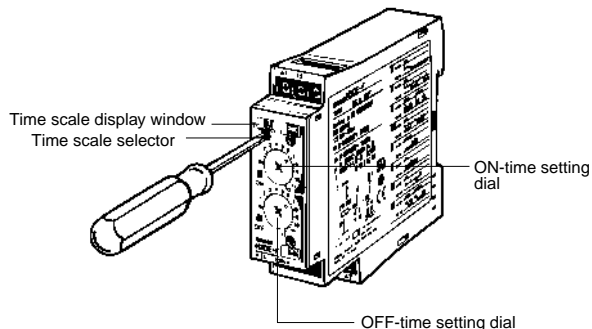

Time Setting

Use the ON/OFF-time setting dial to set the ON/OFF time.

Timing Charts

Operating mode	Timing chart	
Flicker-OFF start	<p>Power (A₁ and A₂)</p> <p>Output relay: NO 15 and 18 (ON indicator)</p> <p>Output relay: NC 15 and 16</p> <p>OFF indicator</p>	
Flicker-ON start	<p>Power (A₁ and A₂)</p> <p>Output relay: NO 15 and 18 (ON indicator)</p> <p>Output relay: NC 15 and 16</p> <p>OFF indicator</p>	

- Note:**
1. The reset time requires a minimum of 0.1 s.
 2. When power is supplied in flicker-ON start mode, the OFF indicator lights momentarily. This, however, has no effect on the performance of the Timer.

Nomenclature

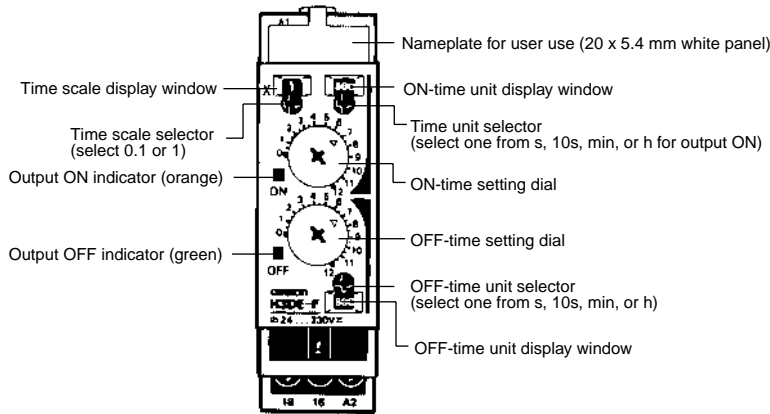

(Front View)

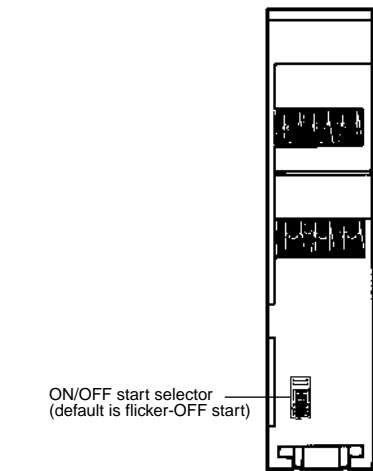

(Bottom View)

ON/OFF Start Selector Switch Settings

Setting	Operating mode
	Flicker-ON start
	Flicker-OFF start

Dimensions

H3DE-F

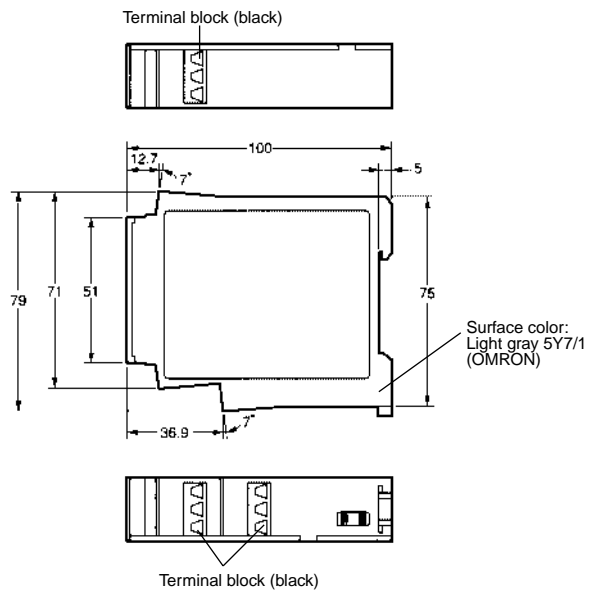
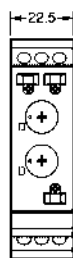
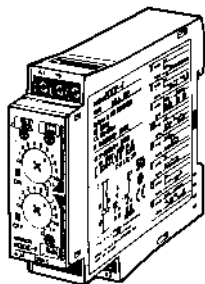

Solid-state Star-delta Timer H3DE-G

- A wide star-time range (up to 120 seconds) and star-delta transfer time range (up to 0.5 seconds)



Model Number Structure

Model Number Legend

H3DE -
1

1. G: Star-delta timer

Ordering Information

List of Models

Supply voltage	Model
24 to 230 VAC/VDC	H3DE-G

Accessories (Order Separately)

Mounting Track	50 cm (l) x 7.3 mm (t)	PFP-50N
	1 m (l) x 7.3 mm (t)	PFP-100N
	1 m (l) x 16 mm (t)	PFP-100N2
End Plate	PFP-M	
Spacer	PFP-S	

Specifications

■ General

Item	H3DE-G
Operating mode	Star-delta operation
Operating/Reset method	Time-limit operation/Self-reset
Terminal block	Clamps two 2.5 mm ² max. bar terminals without sleeves
Terminal screw tightening torque	0.98 N·m max. {approx. 10 kgf·cm max.}
Output type	(Star operation circuit) Relay: SPDT (Delta operation circuit) Relay: SPDT
Mounting method	DIN track mounting (see note)
Attachment	Nameplate
Approved standards	UL508, CSA 22.2 No.14 Conforms to EN61812-1, IEC60664-1 4 kV/2, VDE0106/P100 Output category according to IEC60947-5-1 (AC-13; 250 V 5A/AC-15; 250 V 3 A/DC-13; 30 V 0.1 A)

Note: Can be mounted to 35-mm DIN track with a plate thickness of 1 to 2.5 mm.

■ Time Ranges

Time scale display	Star operation time ranges
x 1	1 to 12 s
x 10	10 to 120 s

Star-delta transfer time	Programmable at 0.05 s, 0.1 s, 0.25 s or 0.5 s
--------------------------	--

■ Ratings

Rated supply voltage (see note)	24 to 230 VAC/VDC (50/60 Hz)
Operating voltage range	85% to 110% of rated supply voltage
Power reset	Minimum power-off time: 0.5 s
Reset voltage	24 VAC/DC max.
Power consumption	AC: Approx. 3 VA (1.8 W) at 230 VAC DC: Approx. 0.8 W at 24 VDC
Control output	Contact output: 5 A at 250 VAC with resistive load ($\cos\phi = 1$) 5 A at 30 VDC with resistive load ($\cos\phi = 1$)
Ambient temperature	Operating: -10°C to 55°C (with no icing) Storage: -25°C to 65°C (with no icing)
Ambient humidity	Operating: 35% to 85%

Note: DC ripple rate: 20% max.

■ Characteristics

Accuracy of operating time	±1% max. of FS
Setting error	±10% ± 0.05 s max. of FS
Total tolerance of transfer time	± (25% FS + 5 ms) max.
Influence of voltage	±0.5% max. of FS
Influence of temperature	±2% max. of FS
Insulation resistance	100 MΩ min. at 500 VDC
Dielectric strength	Between current-carrying metal parts and exposed non-current-carrying metal parts: 2,000 VAC (50/60 Hz) for 1 min. Between control output terminals and operating circuit: 2,000 VAC (50/60 Hz) for 1 min. Between contacts not located next to each other: 1,000 VAC (50/60 Hz) for 1 min.
Impulse withstand voltage	3 kV (between power supply terminals) 4.5 kV (between current-carrying metal parts and exposed non-current-carrying metal parts)
Noise immunity	Square-wave noise generated by noise simulator (pulse width: 100 ns/1 μs, 1-ns rise) ±1.5 kV
Static immunity	Malfunction: 4 kV Destruction: 8 kV
Vibration resistance	Malfunction: 0.5-mm single amplitude at 10 to 55 Hz Destruction: 0.75-mm single amplitude at 10 to 55 Hz
Shock resistance	Malfunction: 100 m/s ² Destruction: 1,000 m/s ²
Life expectancy	Mechanical: 10 million operations min. (under no load at 1,800 operations/h) Electrical: 100,000 operations min. (5 A at 250 VAC, resistive load at 360 operations/h)
EMC	(EMI) EN61812-1 Emission Enclosure: EN55011 Group 1 class B Emission AC Mains: EN55011 Group 1 class B Harmonic Current: EN61000-3-2 Voltage Fluctuation and Flickering: EN61000-3-3 (EMS) EN61812-1 Immunity ESD: EN61000-4-2: 6 kV contact discharge (level 3) 8 kV air discharge (level 3) Immunity RF-interference from AM Radio Waves: EN61000-4-3: 10 V/m (80 MHz to 1 GHz) (level 3) Immunity Burst: EN61000-4-4: 2 kV power port and output port (level 3) 1 kV control port with capacitive clamp (level 3) Immunity Surge: EN61000-4-5: 2 kV common mode (level 3) 1 kV differential mode (level 3)
Degree of protection	IP30 (IP20 for terminal block)
Weight	Approx. 120 g

Note: For reference:

A maximum current of 0.15 A can be switched at 125 VDC (cosφ=1).

A maximum current of 0.1 A can be switched if L/R is 7 ms.

In both cases, a life of 100,000 operations can be expected.

The minimum applicable load is 10 mA at 5 VDC (failure level: P).

Connections

■ Block Diagram

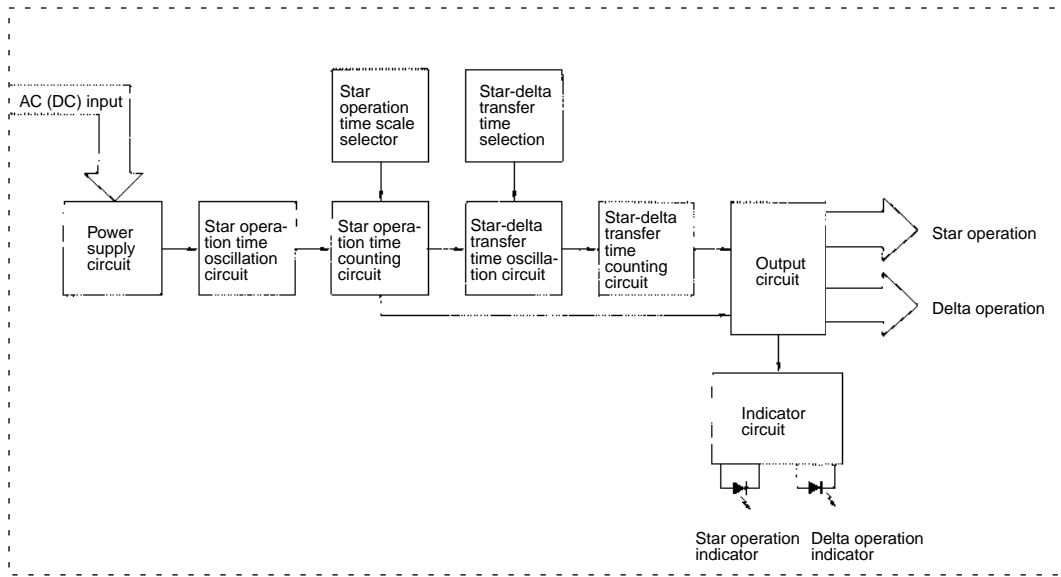

■ I/O Functions

Inputs	---
Outputs	Control output Star output is turned OFF when the dial set value is reached and delta output is ON after the preset transfer time elapses

■ Terminal Arrangement

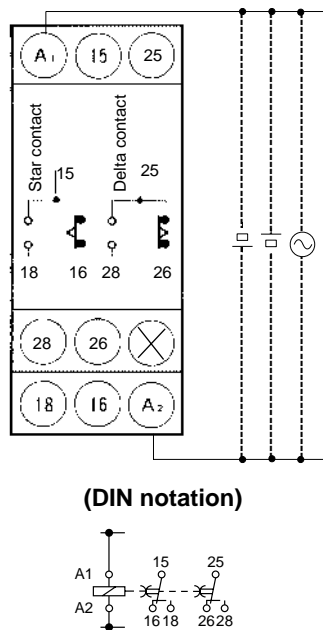

Note: DC supply voltage does not require the designation of polarity.

Operation

Basic Operation

Time Unit Setting

The star-delta transfer time is set to 0.05, 0.1, 0.25 or 0.5 with the star-delta transfer time selector on the lower-right side of the front panel and the set value appears in the star-delta transfer time display window below the selector.

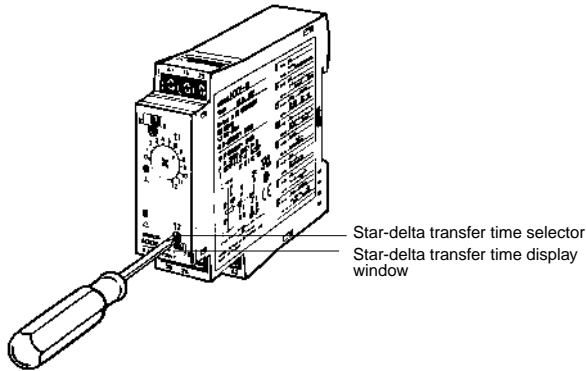

Time Scale Selection

The star operation time scale selector on the upper-left side of the front panel can be set to 1 or 10 as a magnification.

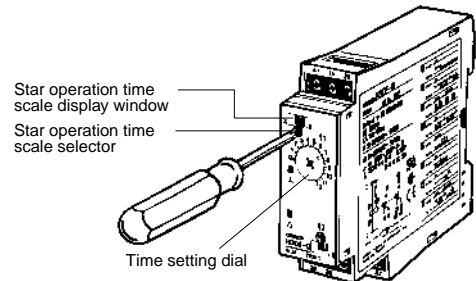

Time Setting

The operation time of the Timer is set with the time setting dial.

Timing Charts

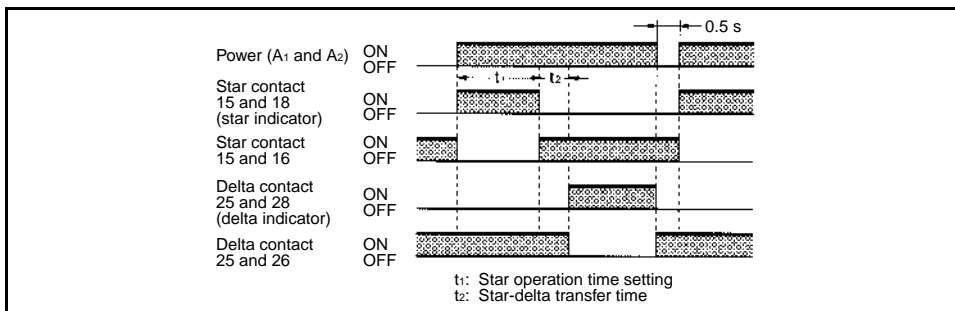

Note: The reset time requires a maximum of 0.5 s.

Nomenclature

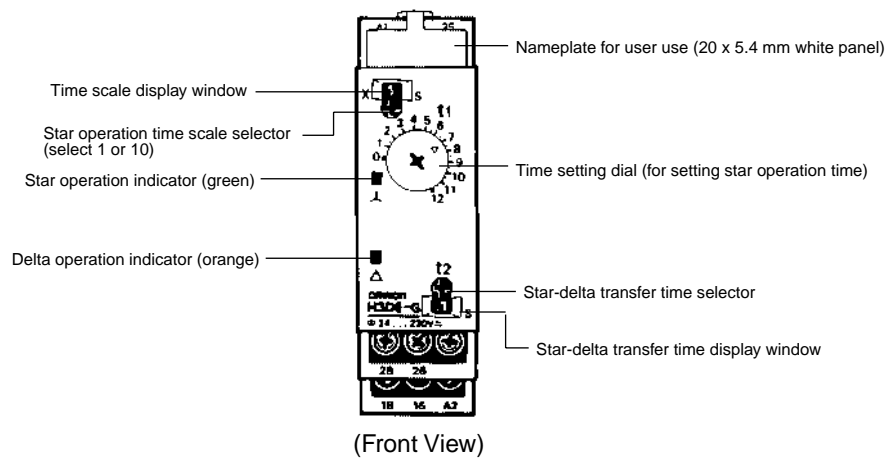

Dimensions

H3DE-G

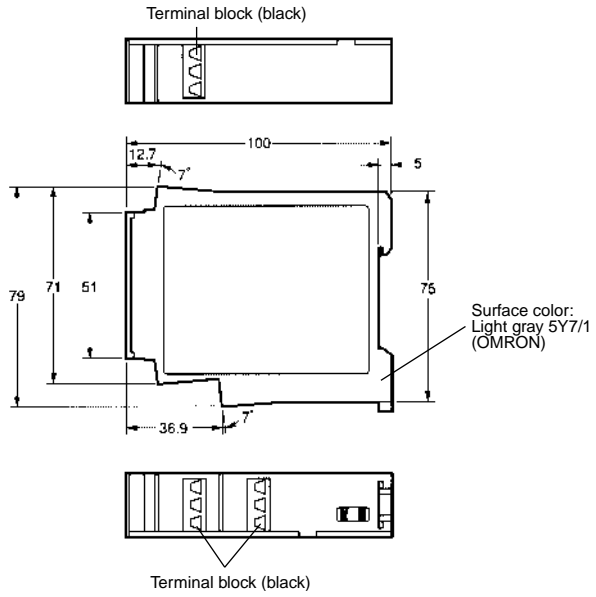
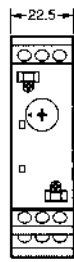
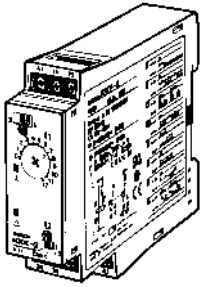

Solid-state Power OFF-delay Timer H3DE-H

- Two delay-time models available.
0.1 to 12 seconds (S Series)
1 to 120 seconds (L Series)
- Covers wide range of supply voltage.



Model Number Structure

Model Number Legend

H3DE -
1

1. H: Power OFF-delay timer

Ordering Information

List of Models

Supply voltage	Model	
	S Series (time range: 0.1 to 12 s)	L Series (time range: 1 to 120 s)
100 to 120 VAC	H3DE-H	H3DE-H
200 to 230 VAC		
24 VAC/VDC		
48 VAC/VDC		

Note: Specify both the model number and supply voltage when ordering.
Example: H3DE-H 24 VAC/DC S

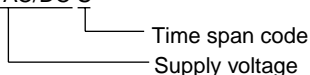

Accessories (Order Separately)

Mounting Track	50 cm (l) x 7.3 mm (t)	PFP-50N
	1 m (l) x 7.3 mm (t)	PFP-100N
	1 m (l) x 16 mm (t)	PFP-100N2
End Plate	PFP-M	
Spacer	PFP-S	

Specifications

■ General

Item	H3DE-H
Operating mode	Power OFF-delay
Operating/Reset method	Instantaneous operation/Time-limit reset
Terminal block	Clamps Two 2.5 mm ² max. bar terminals without sleeves
Terminal screw tightening torque	0.98 N·m max. {approx. 10 kgf·cm max.}
Output type	Relay: SPDT
Mounting method	DIN track mounting (see note)
Attachment	Nameplate
Approved standards	UL508, CSA 22.2 No.14 Conforms to EN61812-1, IEC60664-1 4 kV/2, VDE0106/P100 Output category according to IEC60947-5-1 (AC-13; 250 V 5A/AC-15; 250 V 3 A/DC-13; 30 V 0.1 A)

Note: Can be mounted to 35-mm DIN track with a plate thickness of 1 to 2.5 mm.

■ Time Ranges

Time scale display		Time ranges	Min. power ON time
S series	x 0.1 s	0.1 to 1.2 s	0.1 s minimum
	x 1 s	1 to 12 s	
L series	x 1 s	1 to 12 s	0.3 s minimum
	x 10 s	10 to 120 s	

Note: The Timer will not operate if the specified power-on time is not kept. Be sure to supply power for at least the period specified.

■ Ratings

Rated supply voltage (see note)		100 to 120 VAC (50/60 Hz) 200 to 230 VAC (50/60 Hz) 24 VAC/VDC (50/60 Hz) 48 VAC/VDC (50/60 Hz)
Operating voltage range		85% to 110% of rated supply voltage
Power consumption	24 VAC/VDC Type	AC: Approx. 0.3 VA (0.2 W) at 24 VAC DC: Approx. 0.2 W at 24 VDC
	48 VAC/VDC Type	AC: Approx. 0.5 VA (0.5 W) at 48 VAC DC: Approx. 0.5 W at 48 VDC
	100 to 120 VAC Type	AC: Approx. 0.8 VA (0.7 W) at 120 VAC
	200 to 230 VAC Type	AC: Approx. 1.6 VA (1.0 W) at 230 VAC
Control output		Contact output: 5 A at 250 VAC with resistive load ($\cos\phi = 1$) 5 A at 30 VDC with resistive load ($\cos\phi = 1$)
Ambient temperature		Operating: -10°C to 55°C (with no icing) Storage: -25°C to 65°C (with no icing)
Ambient humidity		Operating: 35% to 85%

Note: The ripple in DC power supply must be 20% max. A single-phase, full-wave rectifying power supply can be connected if the ripple output of the power supply is a maximum of 20% of the whole output.

■ Characteristics

Accuracy of operating time	±1% max. of FS (±1% ±10 ms max. at 1.2-s range)
Setting error	±10% ± 0.05 s max. of FS
Influence of voltage	±0.5% max. of FS (±0.5% ±10 ms max. at 1.2-s range)
Influence of temperature	±2% max. of FS (±2% ± 10 ms max. at 1.2-s range)
Insulation resistance	100 MΩ min. at 500 VDC
Dielectric strength	Between current-carrying metal parts and exposed non-current-carrying metal parts: 2,000 VAC (50/60 Hz) for 1 min. Between control output terminals and operating circuit: 2,000 VAC (50/60 Hz) for 1 min. Between contacts not located next to each other: 1,000 VAC (50/60 Hz) for 1 min.
Impulse withstand voltage	3 kV (or 1 kV for 24/48 VAC/VDC models) (between power supply terminals) 4.5 kV (or 1.5 kV for 24/48 VAC/VDC models) (between current-carrying metal parts and exposed non-current-carrying metal parts)
Noise immunity	Square-wave noise generated by noise simulator (pulse width: 100 ns/1 μs, 1-ns rise) ±1.5 kV (between power supply terminals)
Static immunity	Malfunction: 4 kV Destruction: 8 kV
Vibration resistance	Malfunction: 0.5-mm single amplitude at 10 to 55 Hz Destruction: 0.75-mm single amplitude at 10 to 55 Hz
Shock resistance	Malfunction: 100 m/s ² Destruction: 1,000 m/s ²
Life expectancy	Mechanical: 10 million operations min. (under no load at 1,200 operations/h) Electrical: 100,000 operations min. (5 A at 250 VAC, resistive load at 1,200 operations/h)
EMC	(EMI) Emission Enclosure: EN61812-1 EN55011 Group 1 class A Emission AC Mains: EN55011 Group 1 class A Harmonic Current: EN61000-3-2 Voltage Fluctuation and Flickering: EN61000-3-3 (EMS) Immunity ESD: EN61812-1 EN61000-4-2: 6 kV contact discharge (level 3) 8 kV air discharge (level 3) Immunity RF-interference from AM Radio Waves: EN61000-4-3: 10 V/m (80 MHz to 1 GHz) (level 3) Immunity Burst: EN61000-4-4: 2 kV power port and output port (level 3) 1 kV control port with capacitive clamp (level 3) Immunity Surge: EN61000-4-5: 2 kV common mode (level 3) 1 kV differential mode (level 3)
Degree of protection	IP30 (IP20 for terminal block)
Weight	Approx. 120 g

Note: For reference:

A maximum current of 0.15 A can be switched at 125 VDC (cosφ=1).

A maximum current of 0.1 A can be switched if L/R is 7 ms.

In both cases, a life of 100,000 operations can be expected.

The minimum applicable load is 100 mA at 5 VDC (failure level: P).

Connections

■ Block Diagram

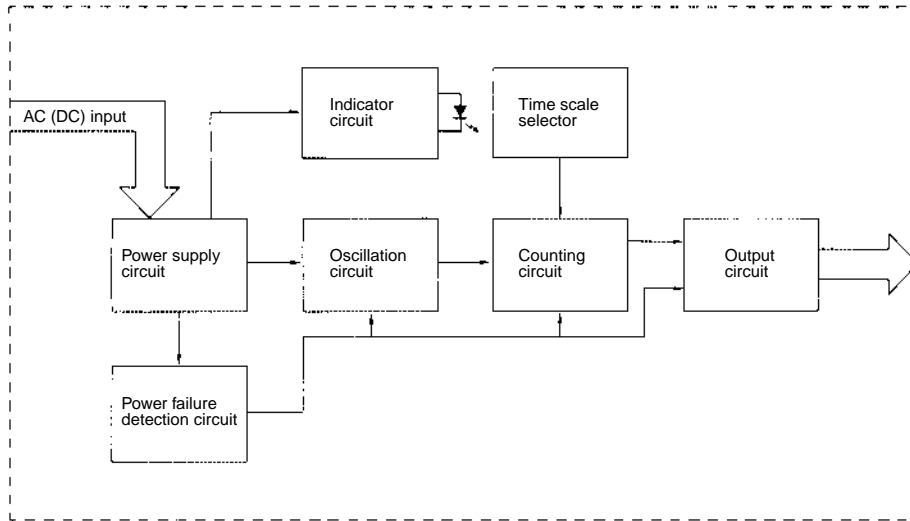

■ I/O Functions

Inputs		---
Outputs	Control output	The Timer operates instantaneously when the Timer is turned ON. The Timer is in counting operation after the Timer is turned OFF and the output of the Timer is turned OFF when the preset time elapses.

■ Terminal Arrangement

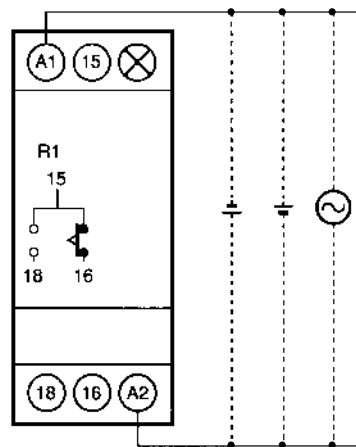

(DIN notation)

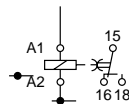

Note: DC supply voltage does not require the designation of polarity.

Operation

Basic Operation

Time Scale Selection

The time scale selector on the upper left-hand side of the front panel of the S Series can be set to 0.1 or 1 and that of the L Series can be set to 1 or 10 as magnification coefficients.

Time Setting

The operating time of the Timer is set with the time setting dial.

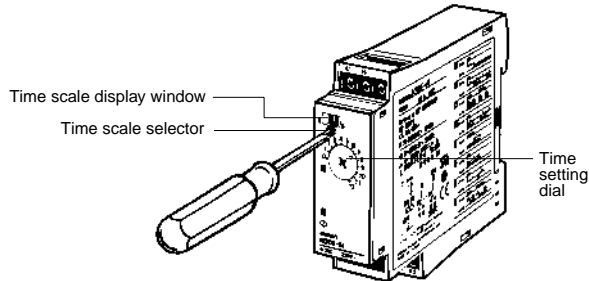

Timing Charts

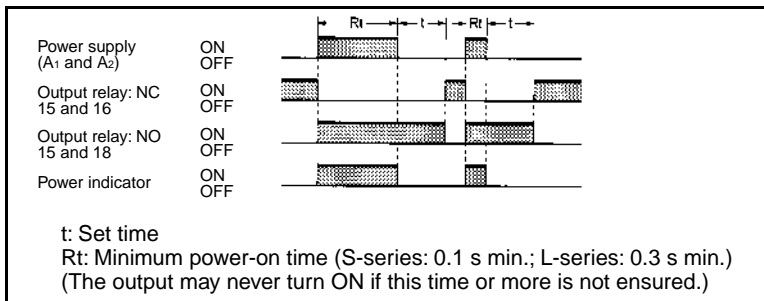

Nomenclature

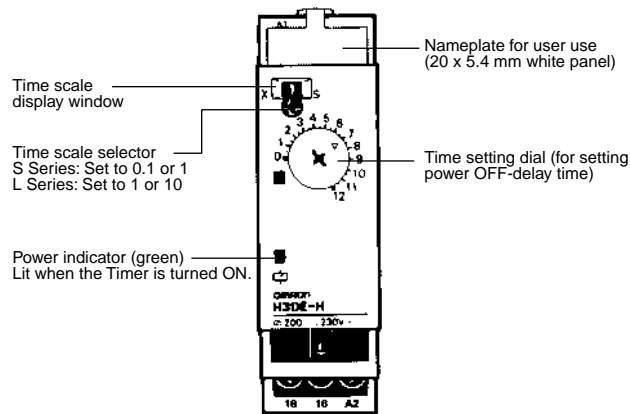

(Front View)

Dimensions

H3DE-H

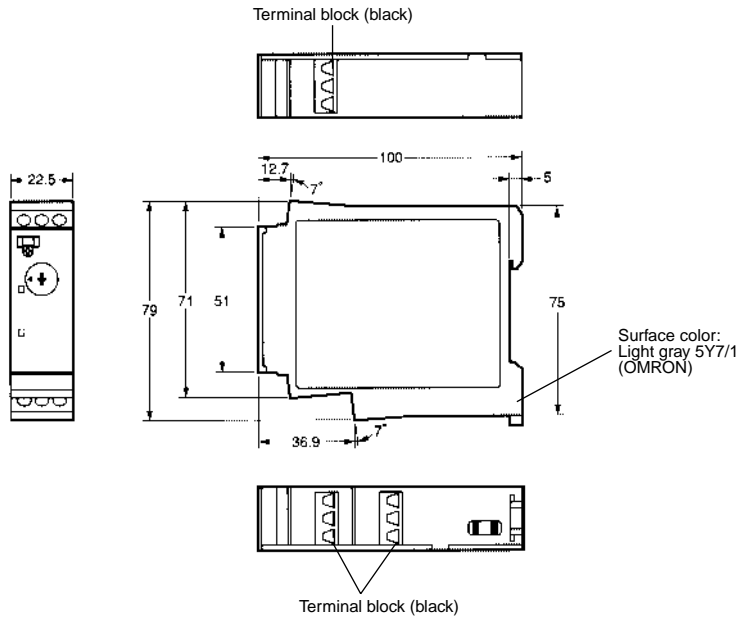
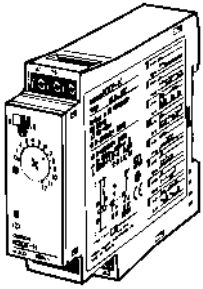

Accessories (Order Separately) (Common)

Note: The undermentioned is common for all H3DE models.

Note: All units are in millimeters unless otherwise indicated.

■ Dimensions

Mounting Track

PFP-100N, PFP-50N

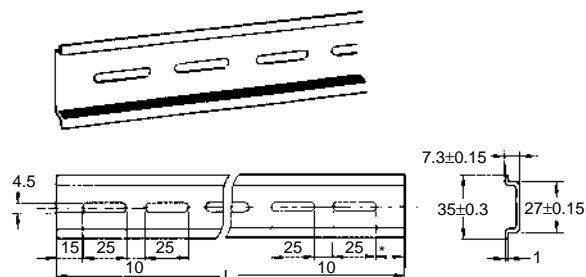

PFP-100N2

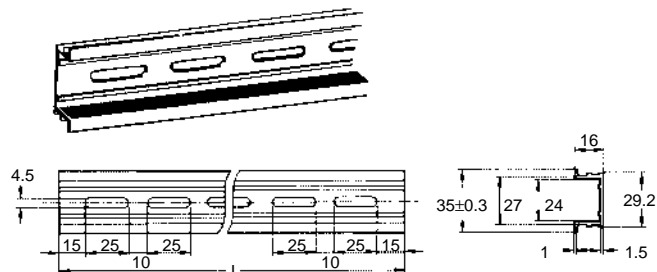

L: Length

1 m	PFP-100N
50 cm	PFP-50N
1 m	PFP-100N2

End Plate

PFP-M

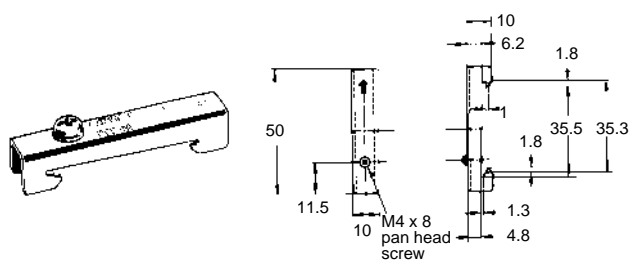

Spacer

PFP-S

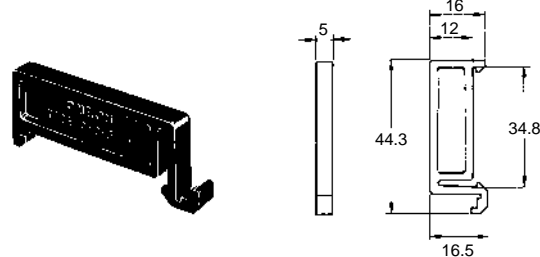

Precautions (Common)

Note: The undermentioned is common for all H3DE models.

■ Changing of Setting

Caution
Do not change the time unit, time scale, operating mode, or output type selector switch while the Timer is in operation or malfunction could result.

■ Mounting and Dismounting

The H3DE should be mounted as horizontally as possible.
When mounting the H3DE on a socket mounting track, hook portion (A) of the Timer to an edge of the track first, and then depress the Timer in the direction of (B).

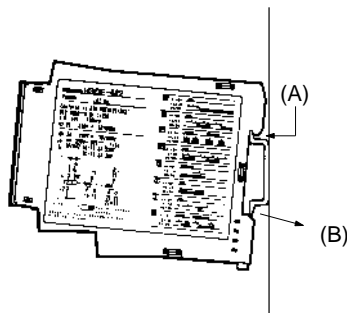

When dismantling the H3DE, pull out portion (C) with a flat-blade screwdriver and remove the Timer from the mounting track.

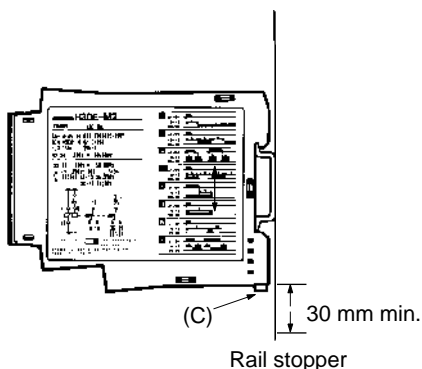

The H3DE can be mounted and dismantled with ease if a distance of 30 mm or more is kept between the H3DE and the top surface of other equipment located below the H3DE.

■ Power Supplies

The H3DE Series is provided with a transformerless power supply system. An electric shock may be received if the input terminal or the output type selector switch is touched while power is being supplied.

Use the bar terminal for wiring the H3DE. Using a stranded-wire terminal may cause a short-circuit due to a stray wire entering into the Timer.

Both AC and DC power supplies can be connected to the power input terminals without regarding polarity.

With the H3DE only, a DC power supply must be connected to the power input terminals as designated according to the polarity of the terminals.

A DC power supply can be connected if its ripple factor is 20% or less and the mean voltage is within the rated operating voltage range of the Timer.

Connect the power supply voltage through a relay or switch in such a way that the voltage reaches a fixed value at once or the Timer may not be reset or a timer error could result.

For the power supply of an input device, use an isolating transformer, of which the primary and secondary windings are mutually isolated and the secondary winding is not grounded.

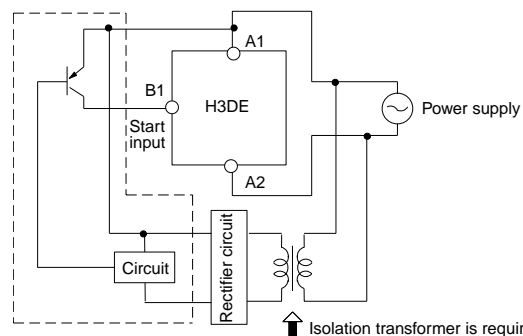

The H3DE-H has a large inrush current; provide sufficient power supply capacity. If the power supply capacity is too small, there may be delays in turning ON the output.

■ Installation

If the load current is continuously being supplied to the Timer for a long period of time, be sure to provide the mounting clearance as shown in the figure below. If used under the conditions other than those specified below, the life of internal components may be shortened due to an excessive rise in the internal temperature.

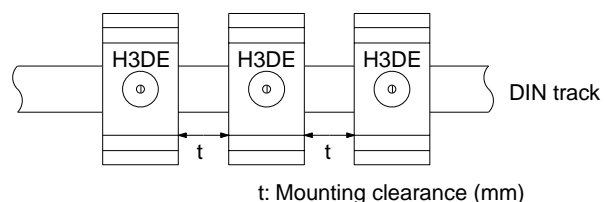

Switching Current vs. Ambient Temperature (When Mounting Two or More H3DE Units Side-by-Side)

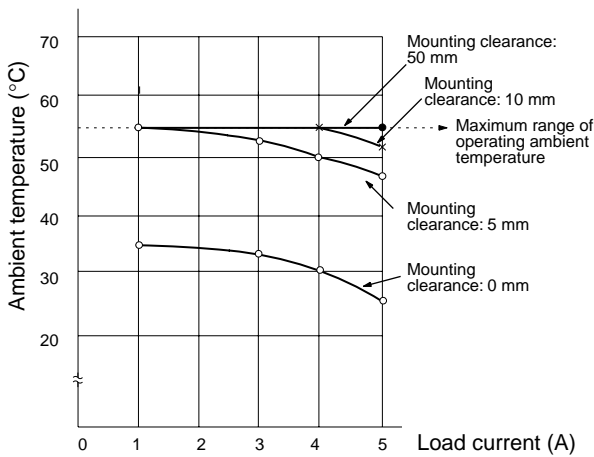

Input/Output

Relationship between Input and Power Supply Circuits

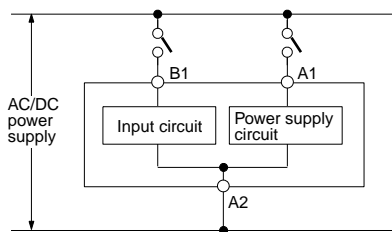

Since the input circuit and the power supply circuit are configured independently, the input circuit can be turned on or off irrespective of the on/off state of the power supply. It must be noted that a voltage equivalent to the power supply voltage is applied to the input circuit.

When connecting a relay or a transistor as an external signal input device, pay attention to the following points to prevent short-circuiting due to a sneak current to the transformerless power supply.

If a relay or transistor is connected to two or more Timers, the input terminals of those Timers must be wired properly so that they will not be different in phase or the terminals will be short-circuited to one another (refer to the figures below).

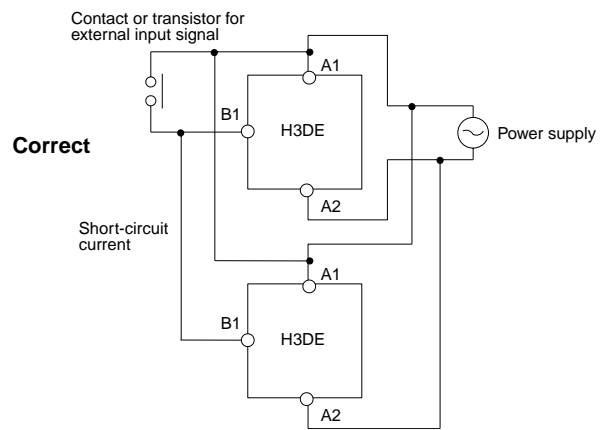
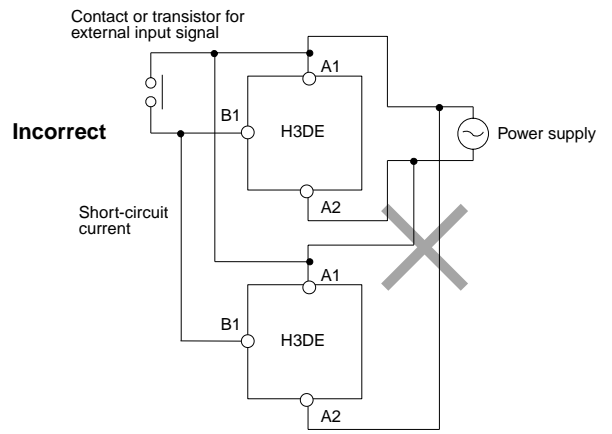

The H3DE Series is provided with a transformerless power supply system.

Input Wires

The input wires must be as short as possible. If the floating capacity of wires exceeds 2,000 pF (approx. 17 m for cables with 120 pF/m), the operation will be affected. Pay particular attention when using shielded cables.

Wiring (H3DE-H)

The H3DE has a high impedance circuit. Therefore, the H3DE may not be reset if the H3DE is influenced by inductive voltage. In order to eliminate any influence of inductive voltage, the wires connected to the H3DE must be as short as possible and should not be installed alongside power lines. If the H3DE is influenced by inductive voltage that is 30% or more of the rated voltage, connect a CR filter with a capacitance of approximately 0.1 μF and a resistance of approximately 120 Ω or a bleeder resistor between the power supply terminals. If there is any residual voltage due to current leakage, connect a bleeder resistor between the power supply terminals.

■ Operation (H3DE-H)

An interval of 3 s minimum is required to turn on the H3DE after the H3DE is turned off. If the H3DE is turned on and off repeatedly with an interval of shorter than 3 s, the internal parts of the H3DE may deteriorate and the H3DE may malfunction.

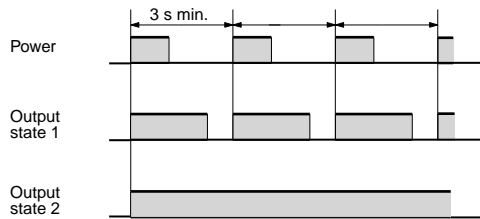

If it is required that the output be turned on repeatedly with an interval of shorter than 3 s, consider use of the H3DE-M2/-M1 in mode D (signal OFF-delay).

■ Precautions for EN61812-1 Conformance

The H3DE as a built-in timer conforms to EN61812-1 provided that the following conditions are satisfied:

The output section of the H3DE is provided only with basic isolation. To ensure reinforced isolation required by the EN61812-1, provide supplementary basic isolation on the load side connected to the output.

The H3DE itself is designed according to the following:

- Overvoltage category III
- Pollution degree 2

On the above basis:

Operation parts on the front and bottom: Reinforced isolation

- With clearance of 5.5 mm and creepage distance of 5.5 mm at 230 VAC

Output: Basic isolation

- With clearance of 3 mm and creepage distance of 3 mm at 230 VAC

■ Environment

When using the Timer in an area with excess electronic noise, separate the Timer, wiring, and the equipment which generates the input signals as far as possible from the noise sources. It is also recommended to shield the input signal wiring to prevent electronic interference.

Organic solvents (such as paint thinner), as well as very acidic or basic solutions can damage the outer casing of the Timer.

Do not use the Timer in places where it is exposed to dust, corrosive gas, or direct sunlight.

When storing the Timer, make sure that the ambient temperature and humidity are within the rated values. Leave the Timer at room temperature for at least three hours before using the Timer if it has been stored at an ambient temperature of -10°C or below.

■ Others

If the Timer is mounted on a control board, dismantle the Timer from the control board or short-circuit the circuitry of the power board before carrying out a voltage withstand test between the electric circuitry and non current-carrying metal part of the Timer, in order to prevent the internal circuitry of the Timer from damage.

It must be noted that although the electrical life expectancy of the H3DE Timer shown in the catalog is the same as the H3DR Timer shown in the catalog, the actual performance varies because the built-in relays are different as follows:

Built-in relay for the H3DR: G2R; 100,000 operations min. (10 A for SPDT and 5 A for DPDT at 250 VAC, resistive load at 1,800 operations/h.)

Built-in relay for the H3DE: G6RN; 50,000 operations min. (8 A at 250 VAC, resistive load at 360 operations/h.)



Ph: 03 5278 8222 Fax: 03 5278 9761
65 Douro Street, North Geelong VIC 3215
www.factorycontrols.com.au

ALL DIMENSIONS SHOWN ARE IN MILLIMETERS.

To convert millimeters into inches, multiply by 0.03937. To convert grams into ounces, multiply by 0.03527.