

Smart Sensors (with Ultra-High-Speed CCD Camera) ZFV Series



Ph: 03 5278 8222 Fax: 03 5278 9761
65 Douro Street, North Geelong VIC 3215
www.factorycontrols.com.au



Ordering Information

■ Sets of Sensor Head and Amplifier Unit

Type	NPN	PNP
Narrow View/Single Function	ZFV-R1010	ZFV-R1015
Narrow View/Standard	ZFV-R1020	ZFV-R1025
Wide View/Single Function	ZFV-R5010	ZFV-R5015
Wide View/Standard	ZFV-R5020	ZFV-R5025

■ Sensor Heads

Appearance	Type	Working length	Sensing area	Model
	Narrow View	34 to 49 mm (variable)	5 × 4.6 mm (H × V) to 9 × 8.3 mm (H × V)	ZFV-SR10
	Wide View	38 to 194 mm (variable)	10 × 9.2 mm (H × V) to 50 × 46 mm (H × V)	ZFV-SR50

■ Amplifier Units

Appearance	Type	Power supply	Output type	Model
	Single Function	24 VDC ± 10%	NPN	ZFV-A10
			PNP	ZFV-A15
	Standard		NPN	ZFV-A20
			PNP	ZFV-A25

■ Accessories (Order Separately)

Data Storage Units

Appearance	Power supply	Output type	Model
	24 VDC	NPN	ZS-DSU11
		PNP	ZS-DSU41

Controller Link Unit

Appearance	Model
	ZS-XCN

Sensor Head Extension Cable

Cable length	Model	Quantity
3 m	ZFV-XC3BV2 (See note.)	1
8 m	ZFV-XC8BV2	1

Note: ZFV-XC3BRV2 Robot Cable is also available.

Panel-mounting Adapter

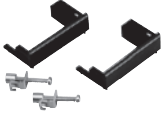
Appearance	Model	
	ZS-XPM1	First Unit
	ZS-XPM2	Additional Units (for expansion)

Specifications

■ Sensor Heads

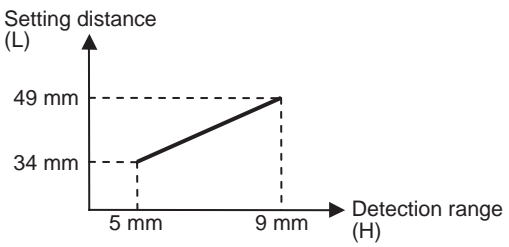
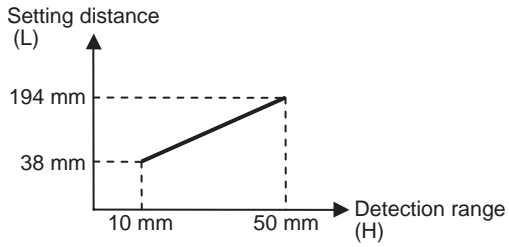
Item	ZFV-SR10 (Narrow View)	ZFV-SR50 (Wide View)
Setting distance (L)	34 to 49 mm	38 to 194 mm
Detection range (H × V)	5 × 4.6 mm to 9 × 8.3 mm	10 × 9.2 mm to 50 × 46 mm
Relation between setting distance and detection range		
Guide light	Provided (center, sensing area)	
Built-in lens	Focus: f15.65	Focus: f13.47
Object lighting method	Pulse lighting	
Object light source	Eight red LEDs	
Sensing element	1/3-inch CCD, partial scan	
Shutter	Electronic shutter, shutter time: 1/1,000 to 1/4,000	
Power supply voltage	15 VDC (Supplied from Amplifier Unit.)	
Current consumption	Approx. 200 mA	
Dielectric strength	1,000 VAC, 50/60 Hz for 1 min	
Vibration resistance (destruction)	10 to 150 Hz, 0.35-mm single amplitude, 10 times each in X, Y, and Z directions for 8 min	
Shock resistance (destruction)	150 m/s ² , three times each in six directions (up/down, left/right, forward/backward)	
Ambient temperature	Operating: 0 to 40°C, Storage: -25 to 65°C (with no icing or condensation)	
Ambient humidity	Operating and storage: 35% to 85% (with no condensation)	
Ambient atmosphere	Must be free of corrosive gas.	
Connection method	Prewired, Standard cable length: 2 m	
Degree of protection	IEC60529, IP65	
Materials	Case: ABS, Mounting bracket: PBT	
Weight	Approx. 200 g (including mounting bracket and cord)	
Accessories	Mounting bracket (1), Ferrite core (1), Instruction sheet	

■ Amplifier Units

Item	Single-function models		Standard models	
	ZFV-A10	ZFV-A15	ZFV-A20	ZFV-A25
Output method	NPN	PNP	NPN	PNP
Output	NPN: NPN open-collector output, 50 mA max. at 30 VDC, Residual voltage: 1.2 V max. PNP: PNP open-collector output, 50 mA max., Residual voltage: 1.2 V max.			
Inspection items	Pattern (PTRN), Brightness (BRGT)		Patterns (PTRN), Brightness (BRGT), Area (AREA), Width (WID), Position (POSI), Count (CNT), Characters (CHAR)	
Teaching area	Rectangular, one area			
Teaching area size	<ul style="list-style-type: none"> • Pattern (PTRN), Brightness (BRGT): Any rectangular area (256 × 256 max.) • Area (AREA), Width (WID), Position (POSI), Count (CNT), Characters (CHAR): Any rectangular area (full screen max.) 			
Sensing area	Full screen			
Resolution	468 × 432 (H × V) max.			
Bank selection	Supported for 8 banks.			
Response time	Pattern (PTRN), Brightness (BRGT): High-speed: 4 ms, Standard: 8 ms, High-precision: 12 ms Area (AREA), Width (WID), Position (POSI), Count (CNT), Characters (CHAR): 128 × 128: 15 ms max.			
Other functions	Control output switching: ON for OK or ON for NG ON delay/OFF delay, One-shot output, "ECO" mode			
Output signals	(1) Control output (OUTPUT), (2) Enable output (ENABLE), (3) Error output (ERROR)			
Input signals	(1) Simultaneous measurement input (TRIG) or Continuous measurement input (TRIG), Switched by using menu. (2) Bank selection inputs (BANK1 to BANK3) (3) Workpiece still teaching (TEACH) or Workpiece moving teaching (TEACH), Switched by using menu.			
Connect- ing to ZS- DSU	Image log- ging trigger	Stores NG images or all images.		
	Sampling rate	ZFV measurement cycle (See note 1.)		
	Number of logged im- age	Logs up to 128 images in series		
	Number of connected	15 max. (ZFV: 5 Units max., ZS-LDC: 9 Units max., ZS-MDC (See note 2.): 1 Unit max.)		
	External bank func- tion	Amplifier Unit setting data can be saved to the memory card as bank data. Reading bank data enables bank switching.		
Sensor Head interface	Digital interface			
Image display	Compact TFT 1.8-inch LCD (Display dots: 557 × 234)			
Indicators	<ul style="list-style-type: none"> • Judgement result indicator (OUTPUT) • Inspection mode indicator (RUN) 			
Operation interface	<ul style="list-style-type: none"> • Cursor keys (up, down, left, right) • Setting key (SET) • Escape key (ESC) • Operating mode switching (slide switch) • Menu switching (slide switch) • Teaching/Display switching key (TEACH/VIEW) 			
Power supply voltage	20.4 to 26.4 VDC (including ripple)			
Current consumption	600 mA max. (with Sensor Head connected)			
Dielectric strength	1,000 VAC, 50/60 Hz for 1 min between leads and Amplifier Unit case			
Noise immunity	1 kV, Pulse rise: 5 ns, Pulse width: 50 ns, Burst duration: 15 ms, Cycle: 300 ms			
Vibration resistance	Destruction: 10 to 150 Hz, 0.1-mm single amplitude, 10 times each in X, Y, and Z directions for 8 min			
Shock resistance	Destruction: 150 m/s ² , three times each in six directions (up/down, left/right, forward/backward)			
Ambient temperature	Operating: 0 to 50°C Storage: -25 to 65°C (with no icing or condensation)			
Ambient humidity	Operating and storage: 35% to 85%			
Ambient atmosphere	Must be free of corrosive gas.			
Degree of protection	IEC60529, IP20			
Materials	Polycarbonate			
Weight	Approx. 300 g (including cord)			
Accessories	Ferrite core (1), Instruction sheet			

Note 1. This is the sampling rate when logging images. To log measurement data only, use the ZS-DSU settings.

2. Image logging is not possible when the ZS-MDC is connected.

Dimensions

Note: All units are in millimeters unless otherwise indicated.

Sensor Heads

ZFV-SR□

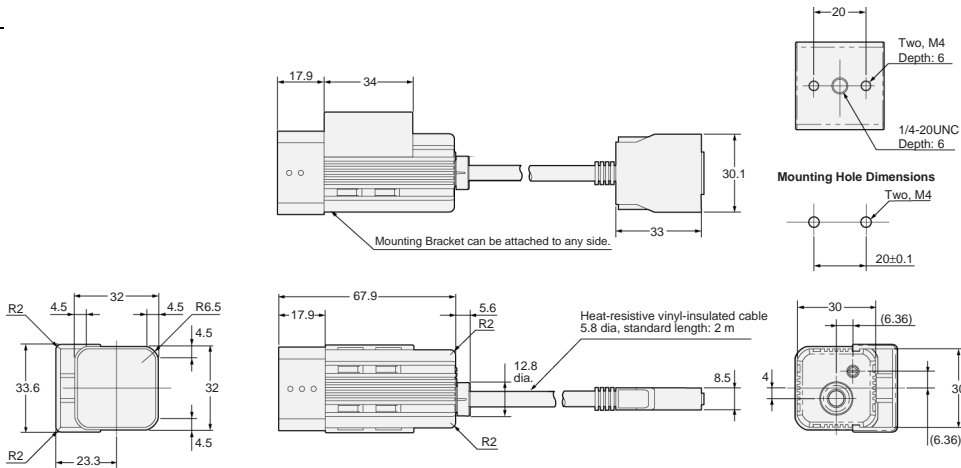

Amplifier Units

ZFV-A□

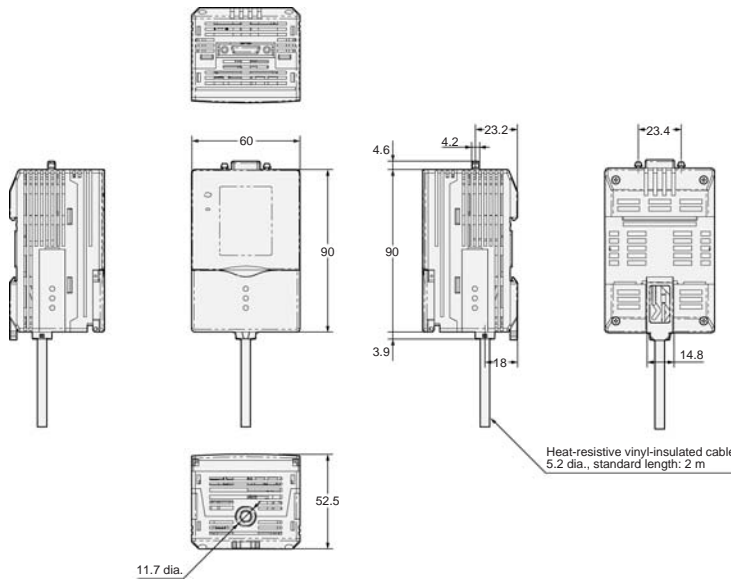

This document provides information mainly for selecting suitable models. Please read the User's manual carefully for information that the user must understand and accept before purchase, including information on warranty, limitations of liability, and precautions.

- The application examples provided in this catalog are for reference only. Check functions and safety of the equipment before use.
- Never use the products for any application requiring special safety requirements, such as nuclear energy control systems, railroad systems, aviation systems, medical equipment, amusement machines, vehicles, safety equipment, or other application involving serious risk to life or property, without ensuring that the system as a whole has been designed to address the risks, and that the OMRON products are properly rated and installed for the intended use within the overall equipment or system.

ALL DIMENSIONS SHOWN ARE IN MILLIMETERS.

To convert millimeters into inches, multiply by 0.03937. To convert grams into ounces, multiply by 0.03527.

Cat. No. Z205-E1-03A

In the interest of product improvement, specifications are subject to change without notice.

OMRON Corporation

Industrial Automation Company

Sensing Devices Division H.Q.

Application Sensors Division

Shiokoji Horikawa, Shimogyo-ku,

Kyoto, 600-8530 Japan

Tel: (81)75-344-7068/Fax: (81)75-344-7107



Ph: 03 5278 8222 Fax: 03 5278 9761

65 Douro Street, North Geelong VIC 3215

www.factorycontrols.com.au