

Smart Sensors Through-beam Laser Type
ZX-LT030

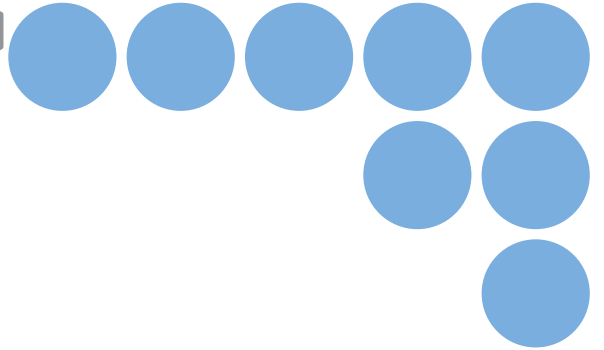

New Line-up of Wide-line-beam Sensors (30-mm Width)!

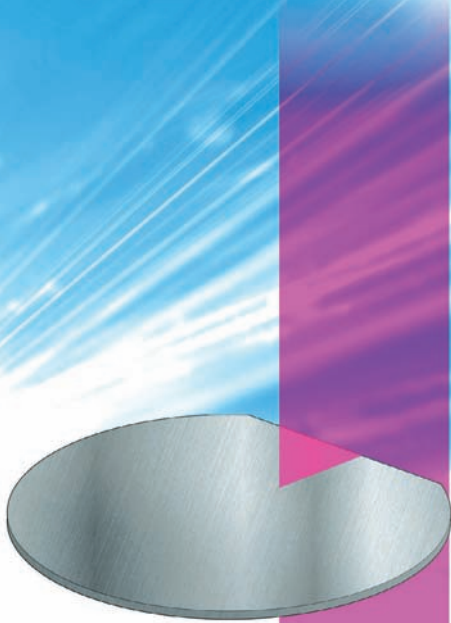

ZX Series multi-point measurement and calculation functions further expand the application coverage.

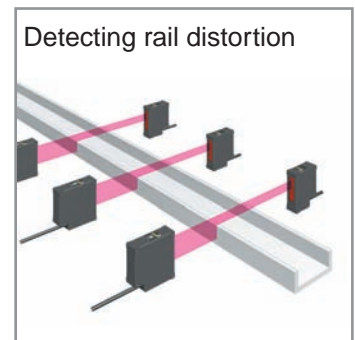
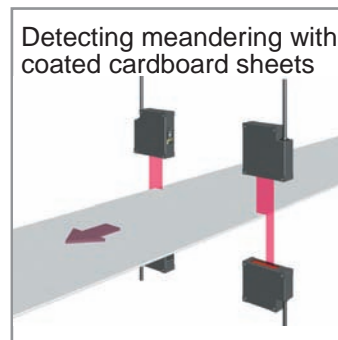
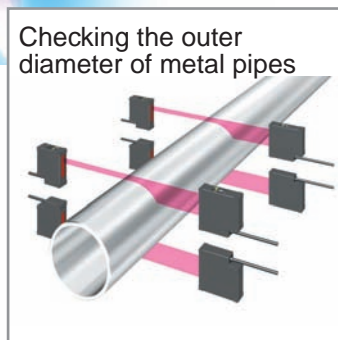
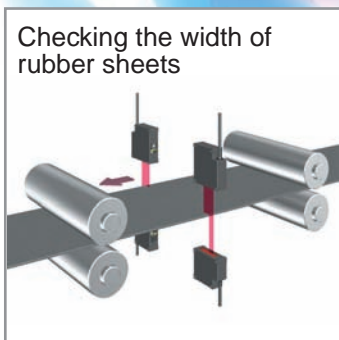

ZX-LT030

Features

Multi-Point Measurement with Calculation Functions

Use of the ZX-CAL2 Calculating Unit makes it easy to configure inspection systems requiring outer diameter (A-B) or width (A+B) calculations.



The ZX-SAM14 Multi-point Smart Sensor Package lets you easily perform multi-point calculations on a personal computer.



ZX-SAM14 Multi-point Smart Sensor Package

Note: The ZX-CN1 Calculating Unit is used for multi-point calculations.

Remote (External) Reference Light Intensity Setting (Use ZX-LDA□1-(N)-01)

The reference light intensity can be set to cancel measurement errors due to the effects of paper dust and other matter when there is no sensing object present. This enables high-speed meandering control.

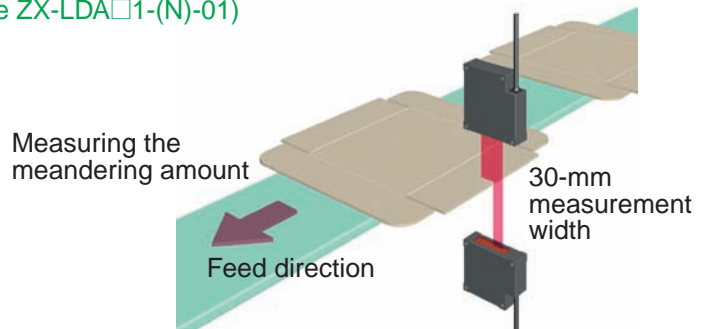

Meandering control for applications where paper dust is generated (for example, with cardboard)

"Front" APC Function

Front APC (Auto Power Control) reduces the effect of light reflecting from wafers. Ideal for high-precision, high-speed orientation flat positioning.

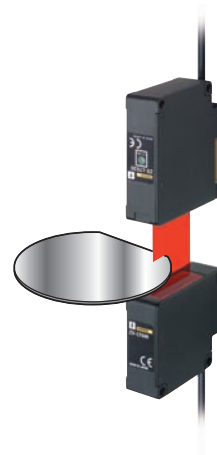

Technology Front APC nulls the effects of light reflections from workpieces with mirror surfaces

The output power of the semiconductor laser in conventional laser sensors has to be monitored and controlled. When reflections from the workpiece enter the built-in monitoring photodiode that is used for this purpose, the output power changes and adversely affects the measurement. The ZX-LT030 uses front APC technology to solve this problem.

*APC: Auto Power Control

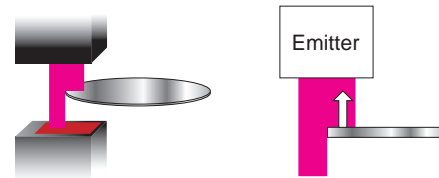

Integrated APC Method (Conventional Laser Sensor)

Light reflected from the workpiece returns directly to the monitoring photodiode inside the laser diode, which reduces the output power and causes measurement errors.

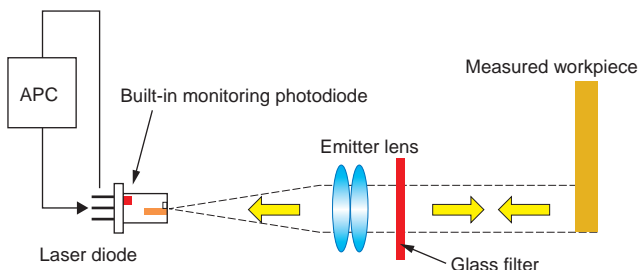

Front APC Method (ZX-LT030)

Light reflected from the workpiece does not return to the external monitoring photodiode, so there is no change in output power.

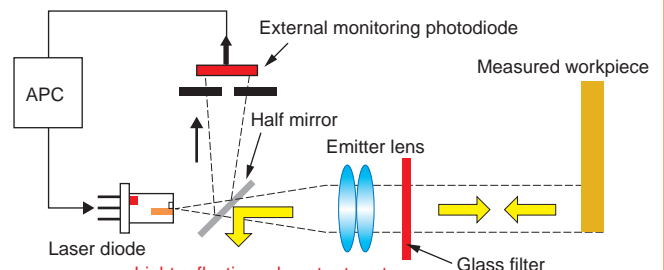

Ordering Information

(Unit: mm)

■ Sensor Heads (Through-beam)

| Optical system | Measuring width | Sensing distance | Resolution (See note.) | Model |
|----------------|-----------------|------------------|------------------------|----------|
| Through-beam | 1 mm dia. | 0 to 2000 mm | 4 μm | ZX-LT001 |
| | 5 mm | 0 to 500 mm | | ZX-LT005 |
| | 10 mm | | | ZX-LT010 |
| | 30 mm | 12 μm | ZX-LT030 | |

Note: For an average count of 64.

■ Amplifier Units

| Appearance | Power supply | Output type | Model |
|---|--------------|-------------|------------|
|  | DC | NPN | ZX-LDA11-N |
| | | PNP | ZX-LDA41-N |

Note: Compatible connection with the Sensor Head.

Ratings

| Model | | ZX-LT001 | ZX-LT005 | ZX-LT010 | ZX-LT030 | |
|----------------------------|--------------|--|---------------------|-----------------------|----------------------|----------------------|
| Item | | | | | | |
| Applicable Amplifier Units | | ZX-LDA11(-N) or ZX-LDA41(-N) | | | | |
| Light source | | Visible-light semiconductor laser with a wavelength of 650 nm; class1 | | | | |
| Maximum output | | 0.2 mW max. | 0.35 mW max. | | 0.2 mW max. | |
| Measurement distance | | 0 to 500 mm | 500 to 2000 mm | 0 to 500 mm | | |
| Measurement width | | 1-mm dia. | 1- to 2.5-mm dia. | 5 mm | 10 mm | 30 mm |
| Minimum sensing object | | 8-μm dia. (opaque) | 50-μm dia. (opaque) | 0.05-mm dia. (opaque) | 0.1-mm dia. (opaque) | 0.3-mm dia. (opaque) |
| Resolution (See note 1.) | | 4 μm (See note 2.) | — | 4 μm (See note 3.) | | 12 μm (See note 4.) |
| Temperature characteristic | | ±0.2% FS/°C (FS = measurement range) | | | | ±0.3% FS/°C |
| Ambient illumination | | Incandescent lamp: 10,000 lx max. | | | | |
| Ambient temperature | | Operating: 0 to 50 °C (with no icing or condensation) Storage: -25 to 70 °C | | | | |
| Ambient humidity | | Operating: 35% to 85% (with no condensation) | | | | |
| Materials | Case | Polyether imide | | | | Zinc die-cast |
| | Cover | Polycarbonate | | | | |
| | Front filter | Glass | | | | |
| Degree of protection | | IP40 | | | | |
| Weight (packed state) | | Approx. 220 g | | | | Approx. 450 g |
| Accessories | | Instruction manual, sensor head-amplifier connection cable | | | | |
| | | Optical axis adjustment seal | | | | Mounting Bracket |

Note 1. This value is obtained by converting the deviation ($\pm 3\sigma$) in the linear output that results when the sensor head is connected to the amplifier unit, into the measurement width.

- For an average count of 64 with measurement distance of 0 to 500 mm. The value is 5 μm for an average count of 32. This is the value that results when a minimum sensing object blocks the light near the center of the 1-mm measurement width.
- For an average count of 64. The value is 5 μm for an average count of 32.
- For an average count of 64. The value is 15 μm for an average count of 32.

Engineering Data

Linearity Characteristic (WD: Distance from Receiver to workpiece)
(Measurement distance: 500 mm)

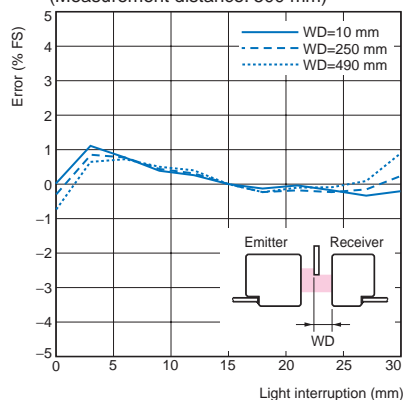

Dimensions

(Unit: mm)

■ Sensor Heads

Emitter

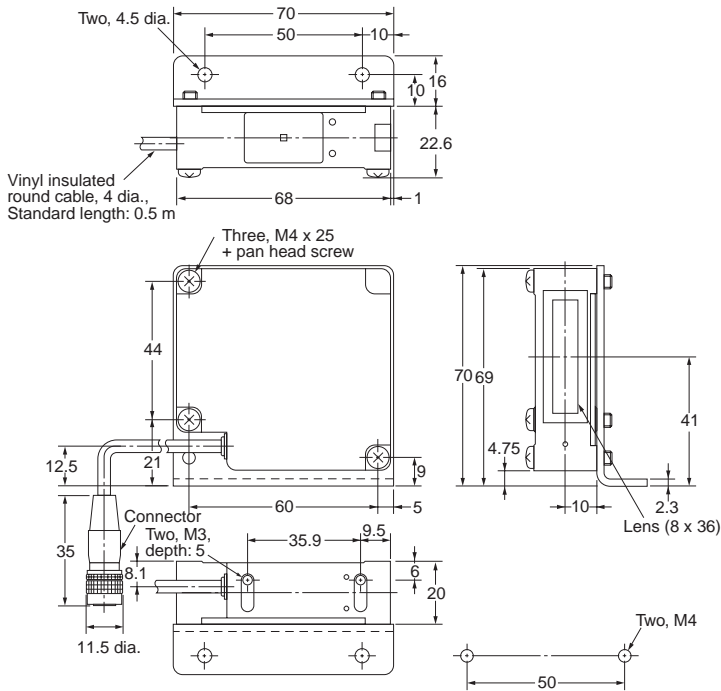

Receiver

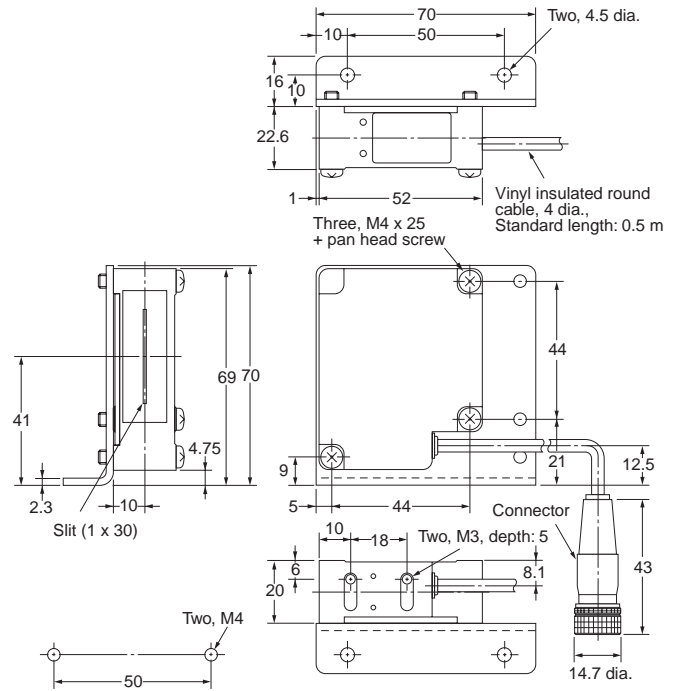

■ Sensor Head - Amplifier Connection Cable

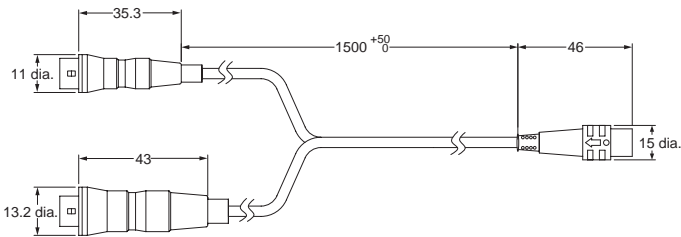

This document provides information mainly for selecting suitable models. Please read the Instruction Sheet carefully for information that the user must understand and accept before purchase, including information on warranty, limitations of liability, and precautions.

Note: Do not use this document to operate the Unit.

OMRON Corporation Industrial Automation Company

Application Sensors Division
Sensing Devices and Components Division H.Q.
Shiokoji Horikawa, Shimogyo-ku,
Kyoto, 600-8530 Japan
Tel: (81)75-344-7068/Fax: (81)75-344-7107

Regional Headquarters

OMRON EUROPE B.V.
Sensor Business Unit,
Carl-Benz-Str. 4, D-71154 Nufringen,
Germany
Tel: (49)7032-811-0/Fax: (49)7032-811-199

OMRON ELECTRONICS LLC
1 East Commerce Drive, Schaumburg,
IL 60173 U.S.A.
Tel: (1)847-843-7900/Fax: (1)847-843-8568

OMRON ASIA PACIFIC PTE. LTD.
83 Clemenceau Avenue,
#11-01, UE Square,
239920 Singapore
Tel: (65)6835-3011/Fax: (65)6835-2711

OMRON CHINA CO., LTD. BEIJING OFFICE
Room 1028, Office Building,
Beijing Capital Times Square,
No. 88 West Chang'an Road,
Beijing, 100031 China
Tel: (86)10-8391-3005/Fax: (86)10-8391-3688

Authorized Distributor:



Ph: 03 5278 8222 Fax: 03 5278 9761
65 Douro Street, North Geelong VIC 3215
www.factorycontrols.com.au

Note: Specifications subject to change without notice.

Cat. No. E362-E1-01
Printed in Japan
0405-0.5M (0405) (H)