

Guard Lock Safety-door Switch D4BL

Release Protective Cover Locks Using Controller Signals or Pushbutton Switches after the Cutting Tool Stops Moving Due to Inertia

- A mechanical lock is applied automatically when the Operation Key is inserted. A high level of safety is achieved using a mechanism where the lock is only released when voltage is applied to the solenoid.
- Conforms to EN (TÜV) standards corresponding to the CE marking.
- Approved by UL, CSA, BIA, SUVA and CCC standards.
- The Switch contact is opened by a direct opening mechanism (NC contacts only) when the protective cover is opened. Direct opening mechanism that is EN-approved is indicated by on the Switch.
- Auxiliary release key ensures easy maintenance and unlocks the door in the case of a power failure.
- Tough aluminum die-cast body incorporating a switch box with degree of protection satisfying IP67, UL, and CSA TYPE6P, 13.
- Equipped with a horizontal and vertical conduit opening.
- Models incorporating easy-to-see indicators for monitoring and those using an adjustable Operation Key for a double door are available.
- The mounting direction of the head can be changed to allow the Operation Key to be inserted from four directions.

Note: Be sure to read the "Safety Precautions" on page A-78 and the "Precautions for All Safety Door Switches" on page A-2.



Safety Door Switches
D4BL

Model Number Structure

Model Number Legend

Switch

D4BL - -
 1 2 3 4 5

1. Conduit Size (2-conduit)

- 1: PG13.5
- 2: G1/2
- 3: 1/2-14NPT

2. Built-in Switch (with Safety Switch and Lock Monitor Switch Contacts)

- C: 1NC/1NO (slow-action) + 1NC (slow-action)
- D: 2NC (slow-action) + 1NC (slow-action)

3. Head Mounting Direction

- R: Four mounting directions possible (right-side mounting at shipping)

4. Door Lock and Release

(Auxiliary Release Key is Incorporated by All Models)

- A: Mechanical lock/24-VDC solenoid release
- B: Mechanical lock/110-VAC solenoid release
- G: 24-VDC Solenoid lock/Mechanical release

5. Indicator

- Blank: Without indicator
- A: 10 to 115 VAC or VDC driving (with orange and green LED indicator unit)

Operation Key (Order Separately)

D4BL - K
 1

1. Operation Key Type

- 1: Horizontal mounting
- 2: Vertical mounting
- 3: Adjustable mounting (Horizontal)



Ordering Information

List of Models

Switches

| Lock method | Conduit size | Voltage for solenoid | Without indicator 1NC/1NO+ 1NC (Slow-action) | With LED indicator 1NC/1NO+ 1NC (Slow-action) | Without indicator 2NC+ 1NC (Slow-action) | With LED indicator 2NC+ 1NC (Slow-action) |
|-----------------|--------------|----------------------|--|---|--|---|
| Mechanical lock | PG13.5 | 24 VDC | D4BL-1CRA | D4BL-1CRA-A | D4BL-1DRA | D4BL-1DRA-A |
| | | 110 VAC | D4BL-1CRB | D4BL-1CRB-A | D4BL-1DRB | D4BL-1DRB-A |
| | G1/2 | 24 VDC | D4BL-2CRA | D4BL-2CRA-A | D4BL-2DRA | D4BL-2DRA-A |
| | | 110 VAC | D4BL-2CRB | D4BL-2CRB-A | D4BL-2DRB | D4BL-2DRB-A |
| | 1/2-14NPT | 24 VDC | D4BL-3CRA | D4BL-3CRA-A | D4BL-3DRA | D4BL-3DRA-A |
| | | 110 VAC | D4BL-3CRB | D4BL-3CRB-A | D4BL-3DRB | D4BL-3DRB-A |
| Solenoid lock | Pg 13.5 | 24 VDC | D4BL-1CRG | D4BL-1CRG-A | D4BL-1DRG | D4BL-1DRG-A |
| | G1/2 | 24 VDC | D4BL-2CRG | D4BL-2CRG-A | D4BL-2DRG | D4BL-2DRG-A |
| | 1/2-14NPT | 24 VDC | D4BL-3CRG | D4BL-3CRG-A | D4BL-3DRG | D4BL-3DRG-A |

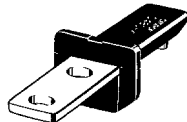
Operation Keys (Order Separately)

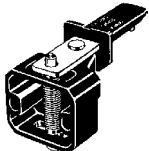
| Mounting type | Model |
|---|---------|
| Horizontal mounting  | D4BL-K1 |
| Vertical mounting  | D4BL-K2 |
| Adjustable mounting (Horizontal)  | D4BL-K3 |

Specifications

Standards and EC Directives

- Conforms to the following EC Directives:
 - Machinery Directive
 - Low Voltage Directive
 - EN1088

Approved Standards

| Agency | Standard | File No. |
|---------------|------------------|--|
| TÜV Rheinland | EN60947-5-1 | R9451050  (Direct opening: approved) |
| BIA | GS-ET-19 | Mechanical lock: 9402293 Solenoid lock: 1998 20462-01 |
| SUVA | SUVA | E6186/2.d |
| UL | UL508 | E76675 |
| CSA | CSA C22.2, No.14 | LR45746 |
| CQC (CCC) | GB14048.5 | 2003010305073836 |

Note: Ask your OMRON representative for information on approved models.

■ Approved Standard Ratings

TÜV (EN60947-5-1), CCC (GB14048.5)

| Item | Standard model | Indicator model |
|-----------------------------------|----------------|-----------------|
| Utilization category | AC-15 | AC-15 |
| Rated operating current (I_e) | 3 A | 6 A |
| Rated operating voltage (U_e) | 250 V | 115 V |

Use a 10-A fuse type gI or gG that conforms to IEC60269 as a short-circuit protection device.

UL/CSA (UL508, CSA C22.2 No. 14)

A300

| Rated voltage | Carry current | Current | | Volt-amperes | |
|---------------|---------------|---------|-------|--------------|--------|
| | | Make | Break | Make | Break |
| 120 VAC | 10 A | 60 A | 6 A | 7,200 VA | 720 VA |
| 240 VAC | | 30 A | 3 A | | |

Note: The UL/CSA approved rating for products with indicators (-A) is 6 A/115 VAC.

■ Characteristics

| | |
|---|---|
| Degree of protection (See note 2.) | IP67 (EN60947-5-1) (This applies for the Switch only. The degree of protection for the key hole is IP00.) |
| Durability (See note 3.) | Mechanical: 1,000,000 operations min. Electrical: 500,000 operations min. (10-A resistive load at 250 VAC) |
| Operating speed | 0.05 to 0.5 m/s |
| Operating frequency | 30 operations/min max. |
| Rated frequency | 50/60 Hz |
| Contact gap | 2 x 2 mm min. |
| Operating characteristics | Direct opening force: 19.61 N min. (EN60947-5-1) (See note 4.) Direct opening travel: 20 mm min. (EN60947-5-1) (See note 4.) All stroke: 23 mm min. |
| Lock holding strength | 700 N min. (GS-ET-19) |
| Insulation resistance | 100 MΩ min. (at 500 VDC) |
| Rated insulation voltage (U_i) | 300 V (EN60947-5-1) |
| Conventional enclosed thermal current (I_{the}) | 10 A (EN60947-5-1) |
| Dielectric strength (U_{imp}) | Impulse dielectric strength (U_{imp}) 4 kV (EN60947-5-1) between terminals of different polarity, between each terminal and ground, and between each terminal and non-current-carrying metal part; 2.5 kV between solenoid and ground (EN60947-5-1) |
| Conditional short-circuit current | 100 A (EN60947-5-1) |
| Pollution degree (operating environment) | 3 (EN60947-5-1) |
| Protection against electric shock | Class I (with ground terminal) |
| Switching overvoltage | 1,500 V max. (EN60947-5-1) |
| Contact resistance | 50 mΩ max. (initial value) |
| Vibration resistance | Malfunction: 10 to 55 Hz, 0.35-mm single amplitude |
| Shock resistance | Destruction: 1,000 m/s ² min. (IEC68-2-27) Malfunction: 300 m/s ² min. (IEC68-2-27) |
| Ambient temperature | Operating: -10°C to 55°C (with no icing) |
| Ambient humidity | Operating: 95% max. |
| Weight | Approx. 800 g |

Note: 1. The above values are initial values.

- The degree of protection is tested using the method specified by the standard (EN60947-5-1). Confirm that sealing properties are sufficient for the operating conditions and environment beforehand. Although the switch box is protected from dust, oil or water penetration, do not use the D4BL in places where dust, oil, water, or chemicals may enter through the key hole on the head, otherwise Switch damage or malfunctioning may occur.
- The durability is for an ambient temperature of 5°C to 35°C and an ambient humidity of 40% to 70%.
- These figures are minimum requirements for safe operation.

Solenoid Coil Characteristics

| Item | 24-VDC mechanical lock models | 110-VAC mechanical lock models | 24-VDC solenoid lock models |
|-------------------------|----------------------------------|--------------------------------|----------------------------------|
| Rated operating voltage | 24 VDC $+10\%$ -15% (100% ED) | 110 VAC $\pm 10\%$ (50/60 Hz) | 24 VDC $+10\%$ -15% (100% ED) |
| Current consumption | Approx. 300 mA | Approx. 98 mA | Approx. 300 mA |
| Insulation | Class F (130°C or less) | | |

Indicator Characteristics

| Item | LED |
|-----------------|-------------------|
| Rated voltage | 10 to 115 VAC/VDC |
| Current leakage | Approx. 1 mA |
| Color (LED) | Orange, green |

Connections

■ Contact Form (Diagrams Show State with Key Inserted and Lock Engaged)

| Model | Contact | Operating pattern | Remarks |
|--------------|-------------|-------------------|--|
| D4BL-□C□□□-□ | 1NC/1NO+1NC | | <p>Only NC contacts 11-12 and 31-32 have an approved direct opening mechanism. </p> <p>The terminals 11-12 and 23-24 can be used as unlike poles.</p> |
| D4BL-□D□□□-□ | 2NC+1NC | | <p>NC contacts 11-12, 21-22, and 31-32 have an approved direct opening mechanism. </p> <p>The terminals 11-12 and 21-22 can be used as unlike poles.</p> |

Note: The EN-approved direct opening mechanism is indicated by on the Switch.

■ Contact Form 2NC + 2NC

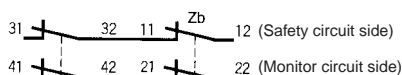

■ Indicator Unit

Dimensions

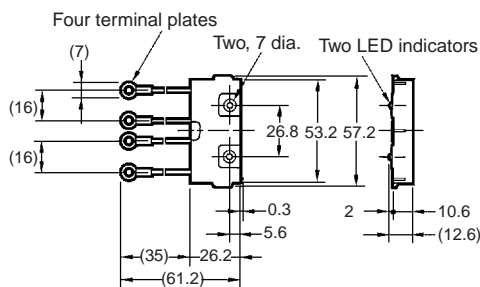

Internal Circuit

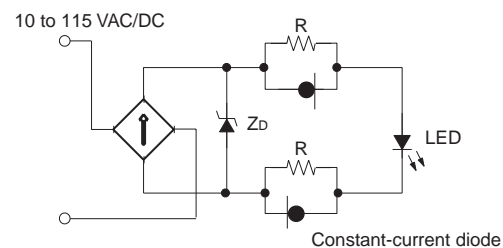

■ Circuit Connection Example

- Terminals 11 and 32 are connected internally and so connect terminals 12 and 31 for safety-circuit input. (GS-ET-19).
- When using indicators, connect them to the auxiliary circuit side (monitor circuit) or the solenoid input terminals as shown below.
- The indicators can be used to confirm the open/closed status of the door, the ON/OFF status of the power supply, and the ON/OFF status of the solenoid.
- Do not connect the indicators in parallel with the direct opening contact. If the indicators are broken, a short-circuit current may flow, causing equipment to malfunction.
- The 24-VDC solenoid terminals have polarity. Confirm the polarity before wiring.
- Be sure to use a special pushbutton switch to stop and start machinery and release locks.

**1. Orange: Lights when the solenoid turns ON.
Green: Lights when the door opens.**

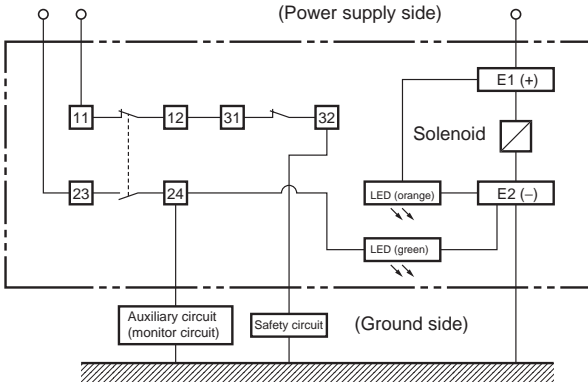

**2. Orange: Lights when the solenoid turns ON.
Green: Lights when power turns ON.**

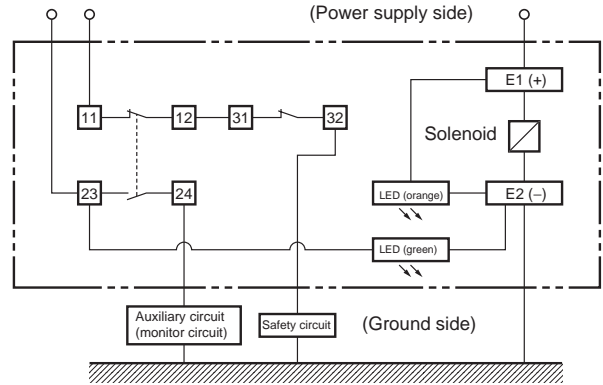

**3. Orange: Lights when the solenoid turns ON.
Green: Lights when door closes.**

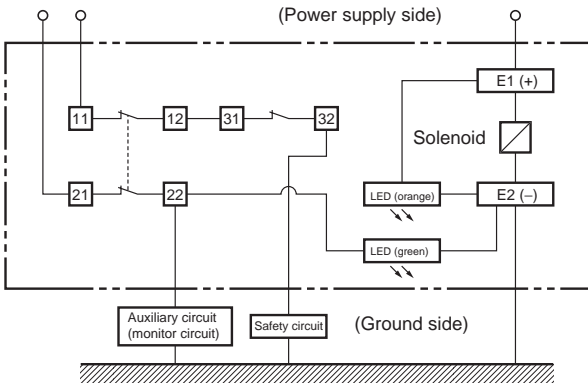

**4. Orange: Lights when the solenoid turns ON.
Green: Lights when power turns ON.**

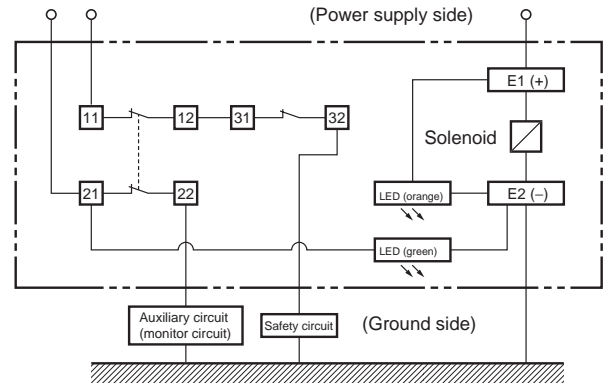

■ Connection Example with OMRON's G9SA Safety Relay Unit

G9SA-321-T□ (24 VAC/VDC) + D4BL-□A-□, □B-□ (Mechanical Lock Type) Circuit Diagram (Manual Reset)

Note: This example circuit is for Category 3.

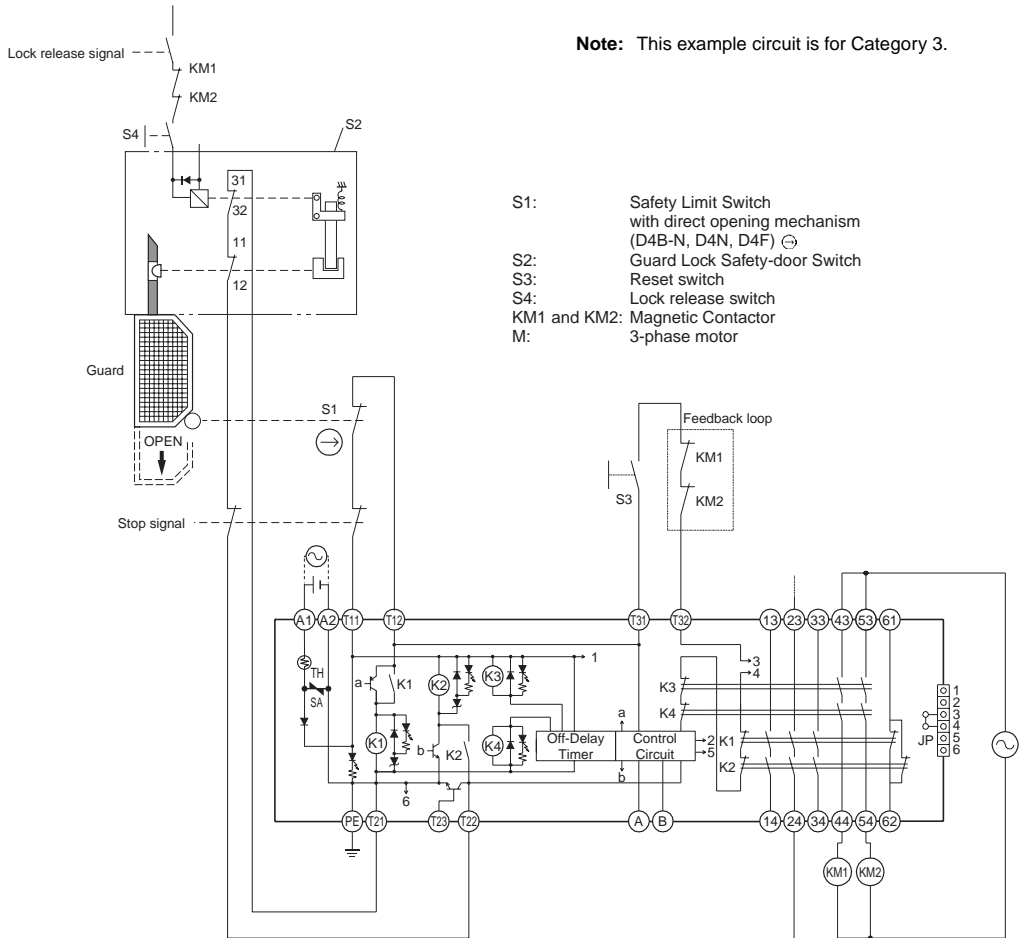

- S1: Safety Limit Switch with direct opening mechanism (D4B-N, D4N, D4F) ☺
- S2: Guard Lock Safety-door Switch
- S3: Reset switch
- S4: Lock release switch
- KM1 and KM2: Magnetic Contactor
- M: 3-phase motor

Timing Chart

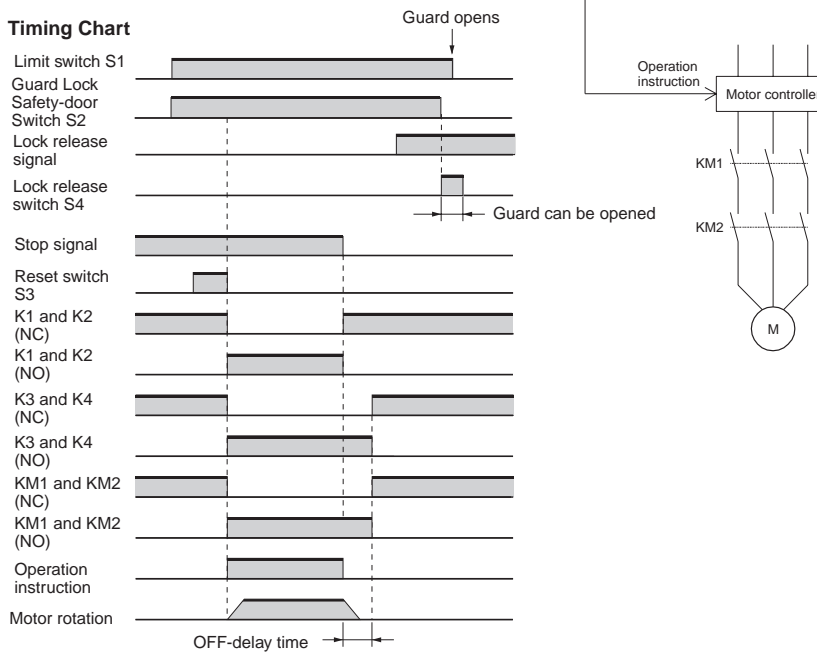

Safety Door Switches D4BL

G9SA-301 (24 VAC/VDC) + D4BL-□G-□ (Solenoid Lock Type) Circuit Diagram (Auto-reset)

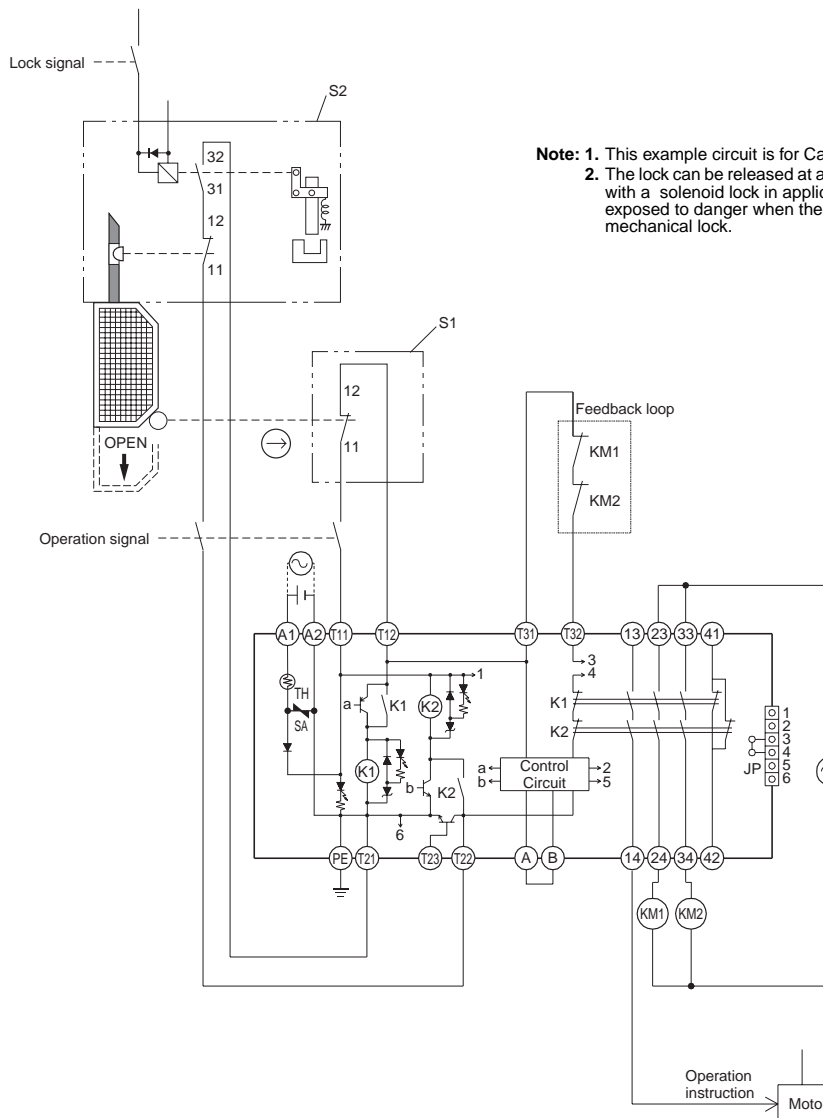

Note 1: This example circuit is for Category 4.
Note 2: The lock can be released at any time. Therefore, do not use a model with a solenoid lock in applications where the operator may be exposed to danger when the guard opens. Use a model with a mechanical lock.

Timing Chart

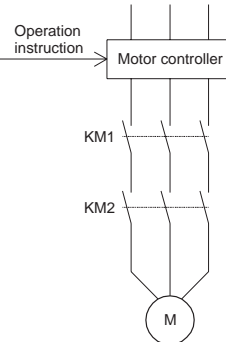
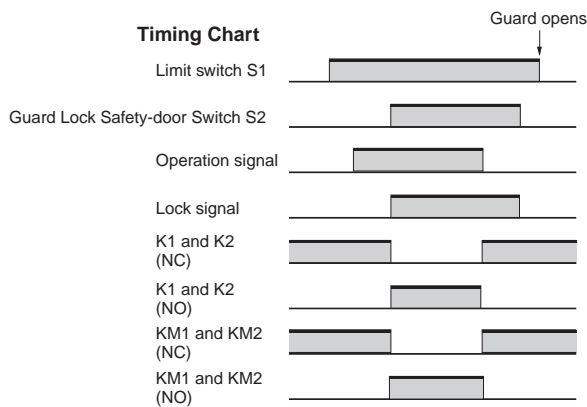

- S1: Safety Limit Switch with direct opening mechanism (D4B-N, D4N, D4F) ⊕
- S2: Guard Lock Safety-door Switch
- KM1 and KM2: Magnetic Contactor
- M: 3-phase motor

Nomenclature

D4BL-□C□□-□

D4BL-□D□□-□

Safety Door Switches
D4BL

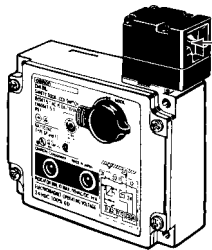
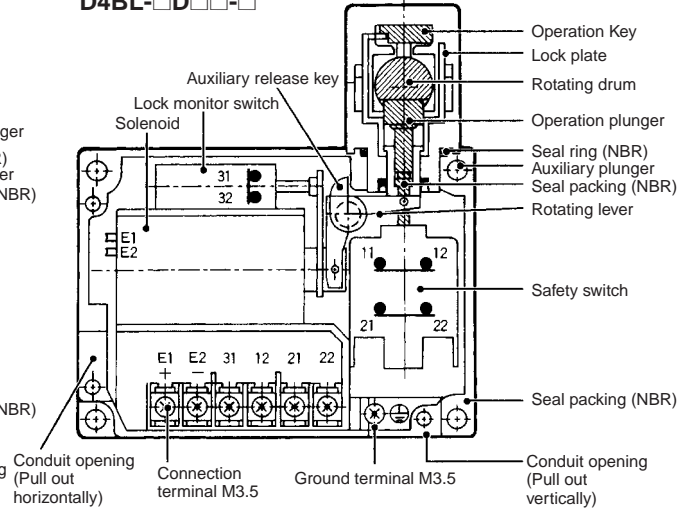
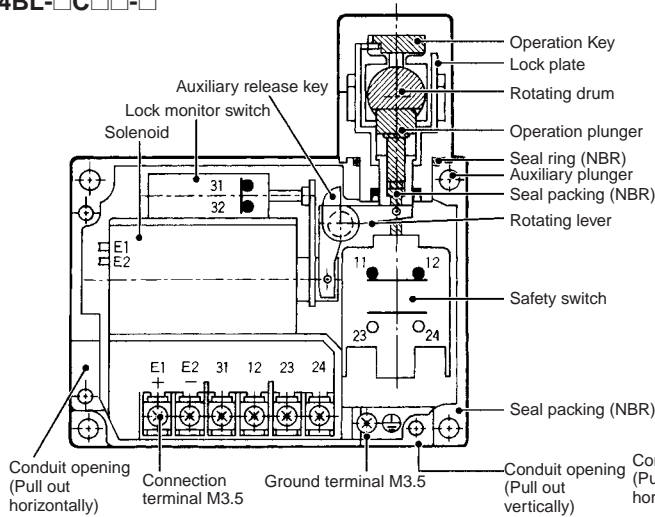

The head can be changed to any of four directions.

Dimensions

- Note:** 1. All units are in millimeters unless otherwise indicated.
 2. Unless otherwise specified, a tolerance of ± 0.4 mm applies to all dimensions.
 3. There are fluctuations in the contact ON/OFF timing for 2NC contacts. Confirm performance before application.

Switches

D4BL-□□□□-□

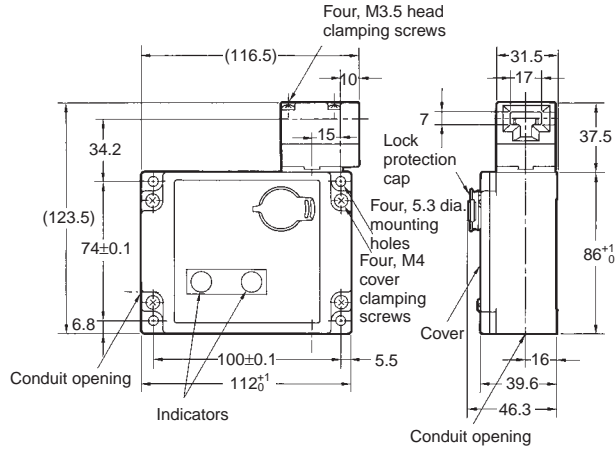
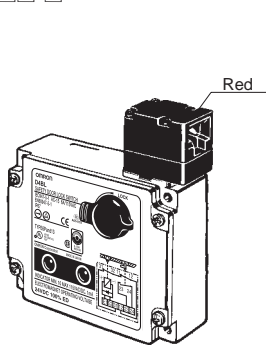

| Operating Characteristics | D4BL-□□□□ |
|------------------------------|--------------|
| Key insertion force | 19.61 N max. |
| Key extraction force | 19.61 N max. |
| Movement before being locked | 15 mm max. |

D4BL-2GRD-AT

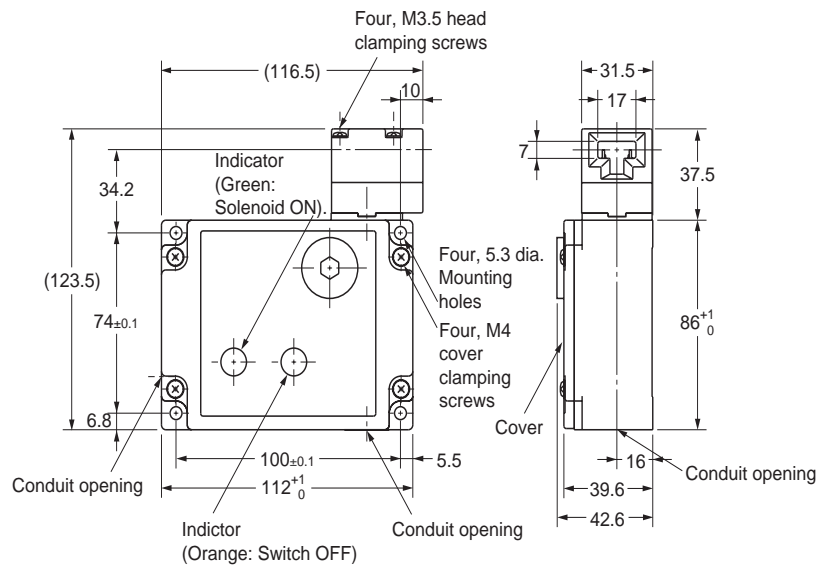
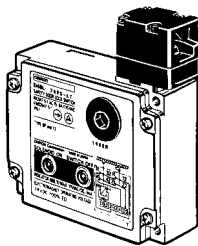

| Operating Characteristics | D4BL-2GRD-AT |
|------------------------------|--------------|
| Key insertion force | 19.61 N max. |
| Key extraction force | 19.61 N max. |
| Movement before being locked | 15 mm max. |

■ Operation Keys

Horizontal Mounting

D4BL-K1

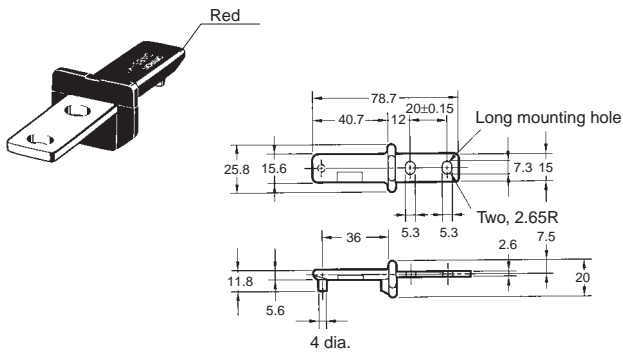

Vertical Mounting

D4BL-K2

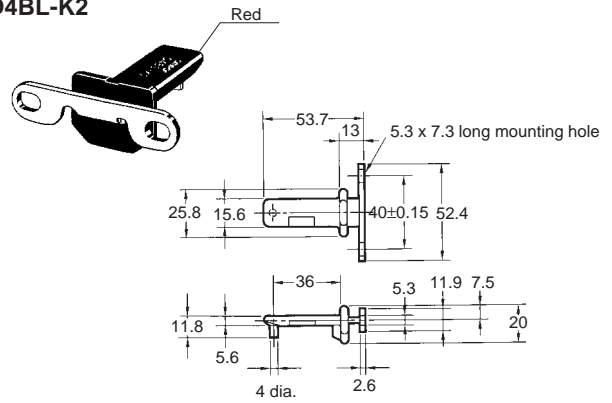

Adjustable Mounting (Horizontal)

D4BL-K3

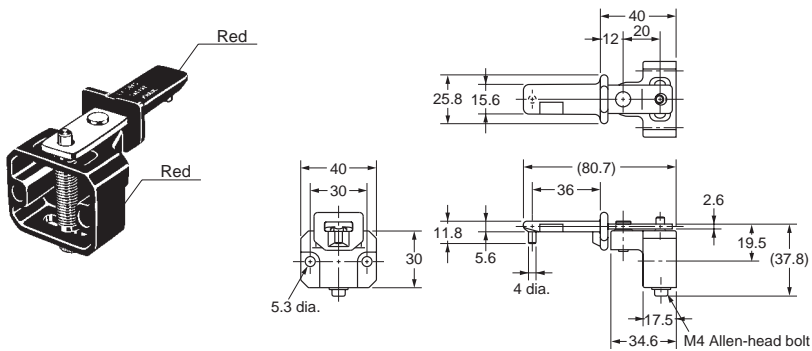

Safety Door Switches
D4BL

■ With Operation Key Inserted

Horizontal Mounting

D4BL + D4BL-K1

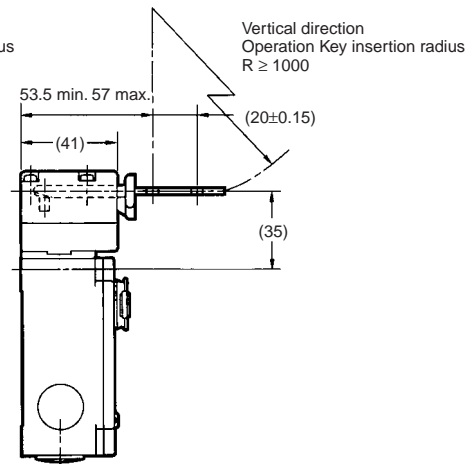
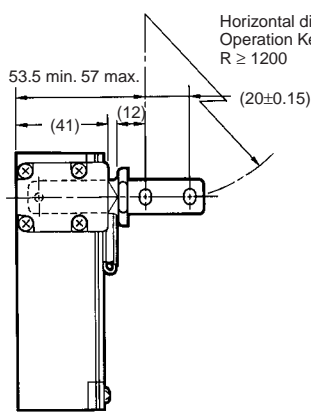
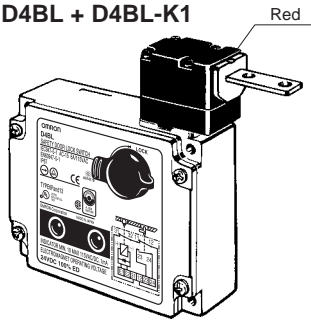

Vertical Mounting

D4BL + D4BL-K2

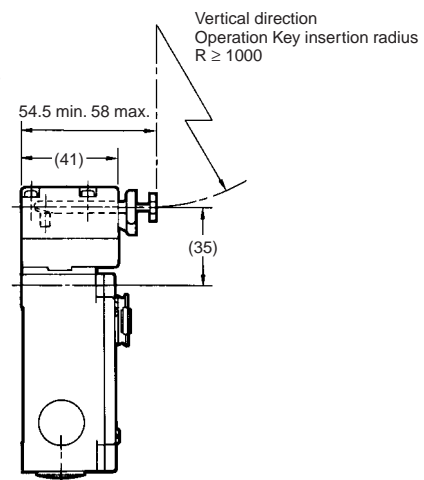
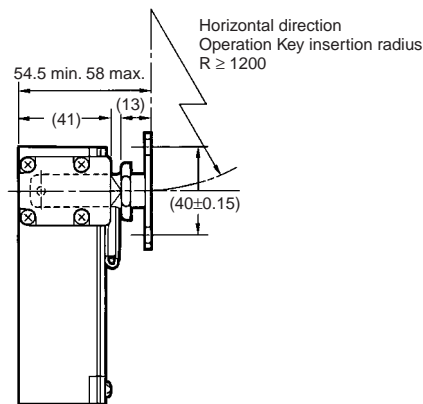
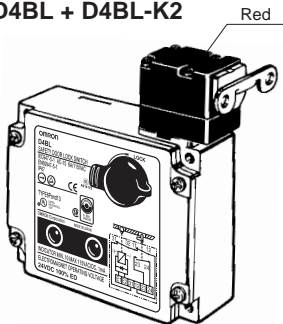

Adjustable Mounting (Horizontal)

D4BL + D4BL-K3

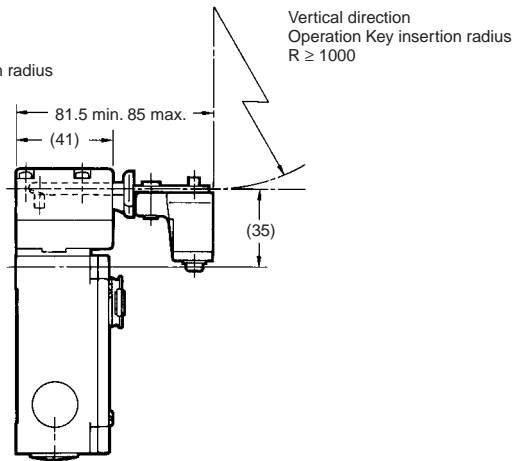
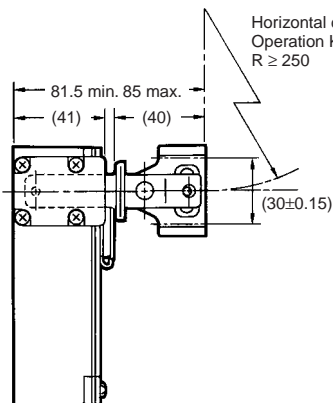
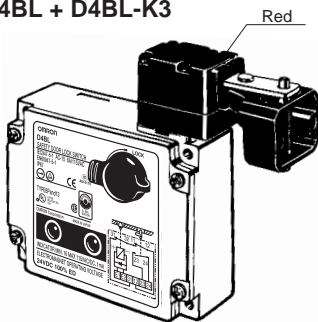

- Note:** 1. Unless otherwise specified, a tolerance of ± 0.4 mm applies to all dimensions.
2. In the above diagrams, the Operation Key is inserted from the front.

Safety Precautions

Refer to the "Precautions for All Switches" on page I-2 and "Precautions for All Safety Door Switches" on page A-2.

CAUTION

Do not insert the Operation Key when the door is open. The machine may operate, possibly resulting in injury. Before using the machine, be sure to remove the shock-absorbing damper, which is provided before shipping.



Precautions for Safe Use

- Do not use the Switch submerged in oil or water or in locations continuously subject to splashes of oil or water. Doing so may result in oil or water entering the Switch. (The IP67 degree of protection of the Switch specifies the amount of water penetration after the Switch is submerged in water for a certain period of time.)
- Although the Switch body is protected from the ingress of dust or water, avoid the ingress of foreign substance through the key hole on the head. Otherwise, accelerated wear or breaking may result.
- Always attach the cover after completing wiring and before using the Switch. Electric shock may occur if the Switch is used without the cover attached.

Connect a fuse in series with the D4BL in series to protect it from short-circuit damage. The value of the breaking current of the fuse must be calculated by multiplying the rated current by 150% to 200%.

To prevent the D4BL from burning due to overvoltage, insert a protection fuse into the solenoid circuit.

Stopper Installation

Do not use a Switch as a stopper. Be sure to install a stopper as shown in the following illustration when mounting the Switch so that the Operation Key is within 0.5 to 5 mm of the set zone.

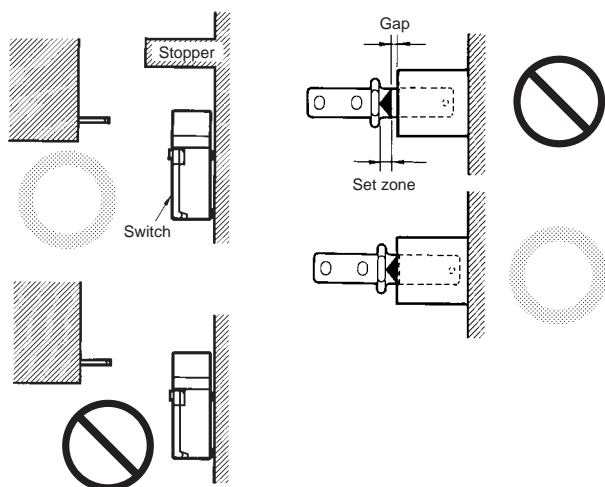

Precautions for Correct Use

Tightening Torque

Loose screws may result in malfunction. Tighten the screws to the specified torques.

| | Type | Torque |
|---|--|------------------|
| 1 | M3.5 terminal screw (including terminal screw) | 0.59 to 0.78 N·m |
| 2 | Cover mounting screw | 1.18 to 1.37 N·m |
| 3 | Head mounting screw | 0.78 to 0.98 N·m |
| 4 | M5 body mounting screw (See note.) | 4.90 to 5.88 N·m |
| 5 | Operation Key mounting screw | 2.35 to 2.75 N·m |
| 6 | Connector | 1.77 to 2.16 N·m |
| 7 | Cap screw | 1.27 to 1.67 N·m |

Note: Use M5 screws. Apply a torque of 4.90 to 5.88 N·m for an Allen-head bolt. For a pan head screw, apply a torque of 2.35 to 2.75 N·m

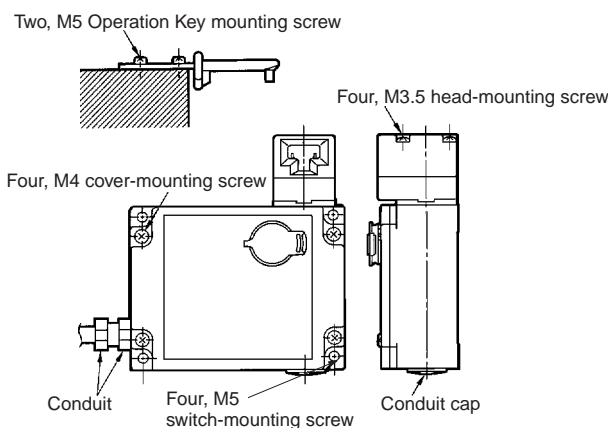

Auxiliary Release Key

The auxiliary release key is used to unlock the D4BL in case of emergency or in case the power supply to the D4BL fails.

Use the enclosed Release Key to change the lock from LOCK to UNLOCK so that the lock will be released and the door can be opened. (Applies only to mechanical locks.)

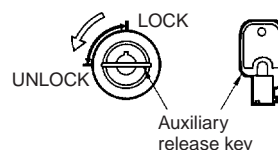

The auxiliary release key applied to the door of a machine room ensures the safety of people adjusting the equipment in the machine room. If the auxiliary release key is set to UNLOCK, the door will not be locked when the door is closed and no power will be supplied to the equipment.

Whenever the lock has been changed to UNLOCK, always return it to LOCK before using the Switch.

Do not use the auxiliary release key to start or stop machines.

To prevent the auxiliary release key from being handled carelessly by unauthorized people, seal the auxiliary release key with sealing wax and the provided seal cap to ensure IP67.

Make sure that the auxiliary release key is kept with the person in charge.

Before attaching the cover to the D4BL, make sure that the auxiliary release key position is set to LOCK.

Solenoid Lock Models

The solenoid lock locks the door only when power is supplied to the solenoid. Therefore, the door will be unlocked if the power supply to the solenoid stops. Therefore, do not use solenoid lock models for machines that may be operating and dangerous even after the machine stops operating.

Switch and Operation Key Mounting

Mount the D4BL and Operation Key with four M5 screws with washers and tighten each screw to the specified torque.

Mounting Dimensions

Switch Mounting Dimensions

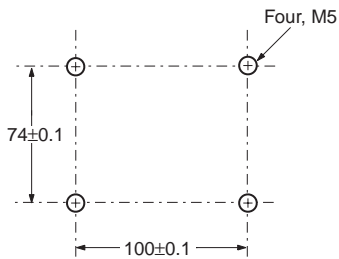

Operation Key Mounting Holes

- Horizontal Mounting
D4BL-K1

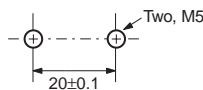

- Vertical Mounting
D4BL-K2

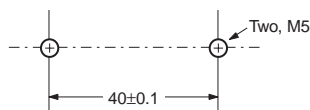

- Adjustable Mounting (Horizontal)
D4BL-K3

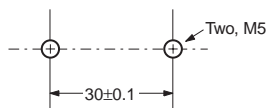

Operation Key

The D4BL is provided with a shock-absorbing damper to protect the D4BL from damage that may result from dropping the D4BL during transportation. Be sure to remove the damper after mounting the D4BL.

The mounting tolerance of the Operation Key is ± 0.3 mm vertically or horizontally. Be sure to mount the D4BL correctly without leaning, otherwise the D4BL may soon break or wear out.

Observe the specified insertion radius for the Operation Key and insert it in a direction perpendicular to the key hole.

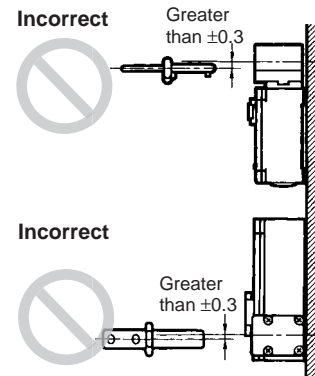

The Operation Key for the D4BL is different from the one for the D4BS.

Head Direction

The head can be mounted in four directions. To remove the head, turn the head by 45° as shown in figures (A) and (B) below.

To change the direction of the head, make sure that the protruding part of the rotating lever engages with the groove of the plunger. Then turn the head clockwise or counterclockwise to the desired direction. At that time, make sure that the groove of the plunger is located under the rotating lever. If the direction of the head is not set when the plunger is rotated by 45° , the groove of the plunger presses the rotating lever. The head, plunger, or the built-in switch may be damaged as a result.

Head Direction Changes

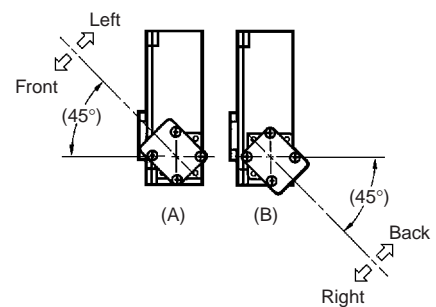

Head Bottom View

Switch Top View

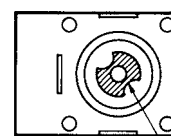

Operation plunger and groove mechanism

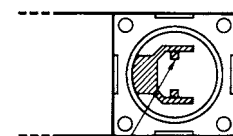

Rotation lever and protruding part

Normal Positions of Rotating Lever and Plunger

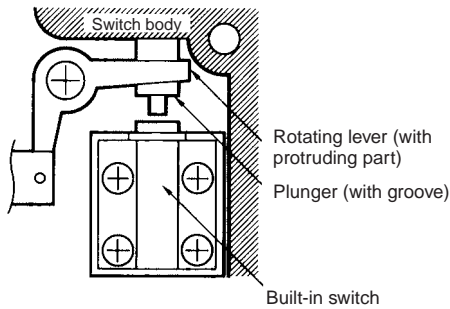

Mounting the Cover

When tightening the cover, first check the specified torque, and then tighten each screw to the that torque. Also, make sure that no foreign material has entered the Switch.

When mounting the cover, make sure that the cover and switch box are properly aligned.

Be sure to check the mechanical lock and solenoid release functions when mounting the D4BL.

If the head direction is changed, recheck the tightening torque of each of screw. Make sure that no foreign materials will enter through the key hole on the head.

Processing and Connecting Cable/Conduit

The following procedures are recommended for mounting and wiring the indicator unit securely.

To ensure IP67, use OMRON's SC-□M and Nippon Flex's ABS-08Pg13.5 and ABS-12 Pg13.5 Connectors.

Recommended cable: UL2464-type cable that is AWG20 to AWG18 (0.5 to 1.0 mm²) in size and has seven conductors

If the 1/2-14NPT is used, cover the cable and conduit end with sealing tape to ensure IP67. Tighten the connector to a torque of 1.77 to 2.16 N·m.

Connect the indicator unit after connecting the seven-conductor cable.

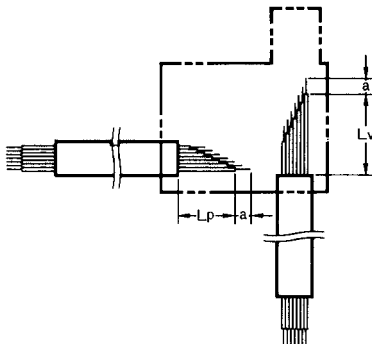

| Terminal no. | Lp (mm) | Lv (mm) | a (mm) |
|----------------|---------|---------|--------|
| E ₁ | 30±2 | 80±2 | 8±1 |
| E ₂ | 35±2 | 75±2 | |
| 31 | 45±2 | 60±2 | |
| 12 | 55±2 | 50±2 | |
| 23 (21) | 65±2 | 45±2 | |
| 24 (22) | 70±2 | 35±2 | |
| ⊕ | 90±2 | 50±2 | |

Properly attach and securely tighten the provided conduit cap to the unused conduit opening when wiring the D4BL.

Cable Connection Example

1. Connect the wires to the terminals in the order shown below for wiring efficiency.

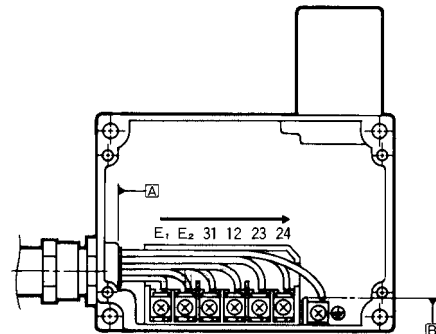

Tighten each wired terminal clockwise to a torque of 0.59 to 0.78 N·m.

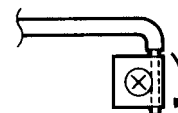

Twist the wire two or three times and make sure that no bare wire exists outside the terminal when tightening the terminal.

2. The insulation sheath of the seven-conductor cable must come into contact with the wall of the conduit mouth, side A or side B.

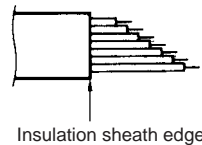

Others

Do not touch the solenoid because the solenoid radiates heat while power is being supplied.

ALL DIMENSIONS SHOWN ARE IN MILLIMETERS.
To convert millimeters into inches, multiply by 0.03937. To convert grams into ounces, multiply by 0.03527.