

Compact Magnetic Non-contact Safety Switches

F3S-TGR-N□C

Ph: 03 5278 8222 Fax: 03 5278 9761
65 Douro Street, North Geelong VIC 3215
www.factorycontrols.com.au

Magnetic Coded Non-contact switches are designed to interlock hinge, sliding or removal guard doors. All coded Non-contact switches have a LED for easy diagnosis.

- Coded actuator for applications requiring anti tamper switches
- Non-contact = no abrasion = no particles
- Excellent coverage of mechanical tolerances
- Can operate behind stainless steel fittings
- Conforms to safety categories up to 4 acc. EN 954-1 and PDF-M acc. EN60947-5-3.

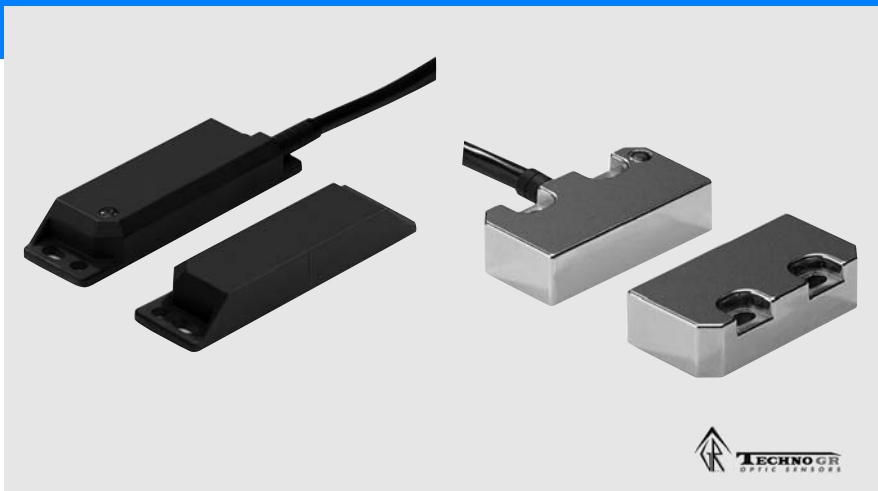

Model Number Structure

F3S-TGR-N□□C-□□-□□

1 2 3 4

1. Type

- L: Elongated Sensor
- S: Small Sensor

2. Housing Material

- P: Plastic Housing
- M: Stainless Steel Housing

3: Contact configuration

- 20: 2 Normally Closed Contacts (NC)
- 21: 2 Normally Closed Contacts (NC) +
1 Normally Open Contact (NO)

4: Cable Length/connection

- 02: 2m Cable
- 05: 5m Cable
- 10: 10m Cable
- M1J8: M12 male connector, 8pin

Ordering Information

Elongated Sensors	Type	Cable Connection	Contact Configuration
	F3S-TGR-NLPC-20-02	2 m pre-wired	2NC
	F3S-TGR-NLPC-20-05 *	5 m pre-wired	2NC
	F3S-TGR-NLPC-20-10	10 pre-wired	2NC
	F3S-TGR-NLPC-20-M1J8	M12, 8-pin	2NC
	F3S-TGR-NLPC-21-02	2 m pre-wired	2NC/1NO
	F3S-TGR-NLPC-21-05 *	5 m pre-wired	2NC/1NO
	F3S-TGR-NLPC-21-10	10 pre-wired	2NC/1NO
	F3S-TGR-NLPC-21-M1J8	M12, 8-pin	2NC/1NO

*. Preferred stock items.

Small Sensor	Type	Cable Connection	Contact Configuration
	F3S-TGR-NSMC-20-02	2 m pre-wired	2NC
	F3S-TGR-NSMC-20-05 *	5 m pre-wired	2NC
	F3S-TGR-NSMC-20-10	10 pre-wired	2NC
	F3S-TGR-NSMC-20-M1J8	M12, 8-pin	2NC
	F3S-TGR-NSMC-21-02	2 m pre-wired	2NC/1NO
	F3S-TGR-NSMC-21-05 *	5 m pre-wired	2NC/1NO
	F3S-TGR-NSMC-21-10	10 pre-wired	2NC/1NO
	F3S-TGR-NSMC-21-M1J8	M12, 8-pin	2NC/1NO

*. Preferred stock items.

Accessories

Safety relay units	G9SA		G9SA-301 G9SA-501 G9SA-321-T075 G9SA-321-T15 G9SA-321-T30
	G9SB		G9SB-2002-C G9SB-2002-A G9SB-200-B G9SB-200-D G9SB-3012-A G9SB-301-B G9SB-3012-C G9SB-301-D
	G9SX		G9SX-BC202-RC G9SX-BC202-RT G9SX-AD322-T15-RC G9SX-AD322-T15-RT G9SX-AD322-T150-RC G9SX-AD322-T150-RT G9SX-ADA222-T15-RC G9SX-ADA222-T15-RT G9SX-ADA222-T150-RC G9SX-ADA222-T150-RT
Safety Network	Safety Network controller		NE1A-SCPU01
	Safety input terminal		DST1-ID12SL-1
	Safety mixed terminal		DST1-MD16SL-1
	Safety mixed terminal (relay out)		DST1-MRD08SL-1
Cables 8-pin	2 m		F39-TGR-SB4-CVLB2R
	5 m		F39-TGR-SB4-CVLB5R
	10 m		F39-TGR-SB4-CVLB10R

Specifications

Mechanical Data

		Elongated Sensor	Small sensor
Operating distance	OFF → ON (Sao)	12 mm Close	
	ON → OFF (Sar)	17 mm Open	
Actuator approach speed	Min.	4mm/s	
	Max.	1000mm/s	
Switching frequency	Max.	1Hz	
Operating temperature		-25°C...+80°C	-25°C...+105°C
Enclosure protection	Flying lead M12 connector	IP 67	
Material		Black Polycarbonate	Stainless steel 316
Mounting bolts		2 x M4 recommended	
Tightening torque	Max.	1Nm	
Mounting position		any	
Mechanical life expectancy		10.000.000 cycles	
Electrical life expectancy		1.000.000 cycles	
	De-rating Safety factor 2	2.000.000 cycles @ 24VDC/100mA	
Cable diameter		6 mm	

Electrical Data

		Elongated Sensor	Small sensor
Power supply		24VDC ±15%	
Power consumption	Max.	50mA	
Switching current	Min.	10mA @ 10VDC	
Rated loads	Max.	100mA @ 24VDC	
NC contacts NO contact		100mA @ 24VDC	
Insulation resistance		100MΩ	
Rated insulation voltage		250VAC	
Output type		electronic output (potential-free optocoupler output)	

Approved Standards

- EN standards certified by TÜV Rheinland
- EN 954-1
- EN 60204-1
- EN/IEC 60947-5-3
- UL 508, CSA C22.2
- BS 5304
- EN 1088-1 conformance

Connection diagram

Cable version

Pin No.	Signal name
red	+24 VDC
blue	GND
black	NC Channel 1, +
white	NC Channel 1, -
yellow	NC Channel 2, +
green	NC Channel 2, -
brown	NO Channel +
orange	NO Channel, -

M12-Connector version

Pin No.	Signal name	Wire color (F39-TGR-SB4-CVLB)
2	+24 VDC	Brown
3	GND	Green
7	NC Channel 1, +	Blue
1	NC Channel 1, -	White
4	NC Channel 2, +	Yellow
6	NC Channel 2, -	Pink
5	NO Channel +	Grey
8	NO Channel, -	Red

Operating characteristics

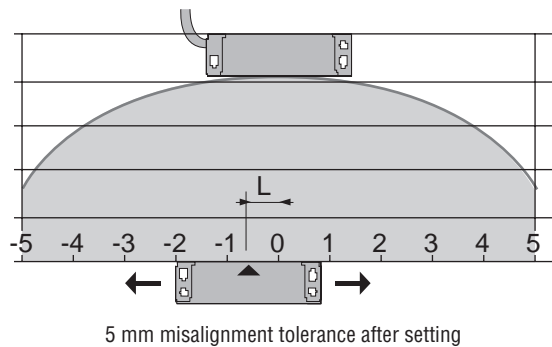

Dimensions

Elongated Sensor (Sensor/Actuator)

F3S-TGR-NLPC

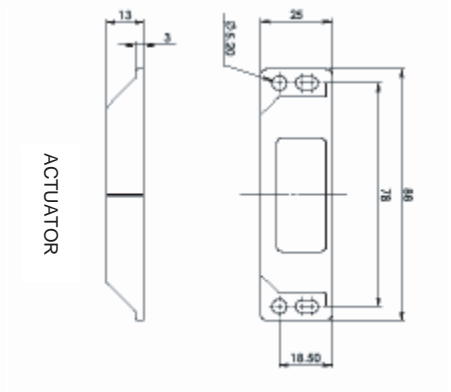
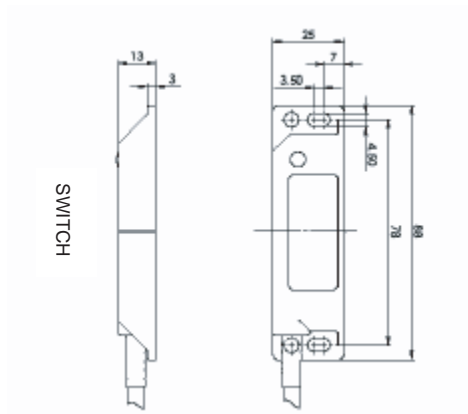

Small Sensor (Sensor/Actuator)

F3S-TGR-NSMC

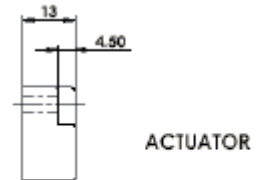
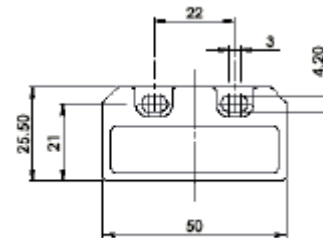
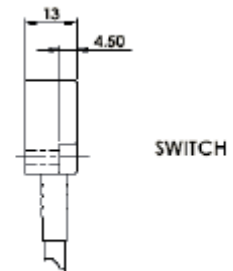
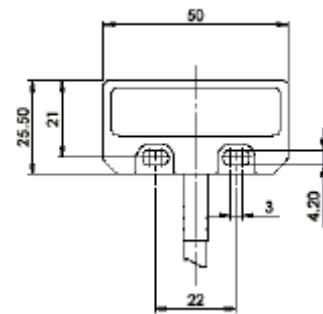

Wiring examples (Single head connection up to category 4 acc. EN954-1)

G9SA

Single Sensor Application with G9SA-301

(up to Safety Category 4 acc. EN954-1)

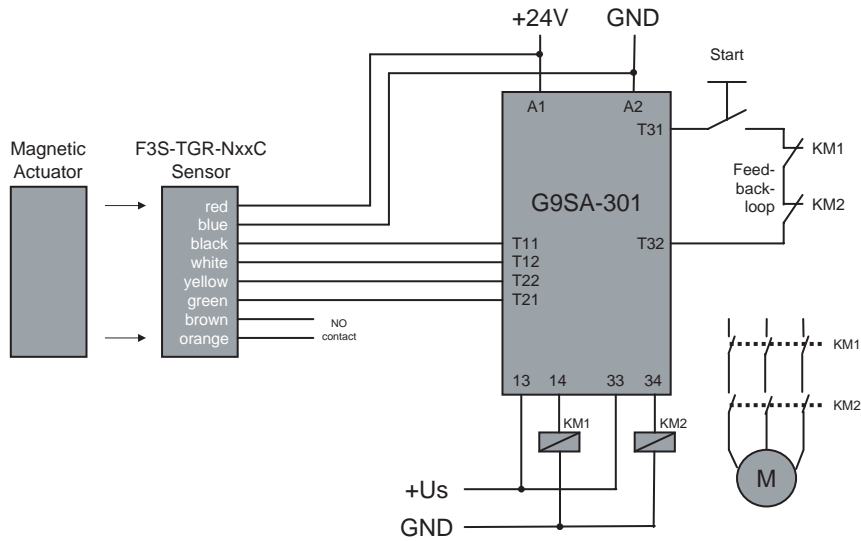

Series connection Application, up to 6 Sensors with G9SA-301

(up to Safety Category 3 acc. EN954-1)

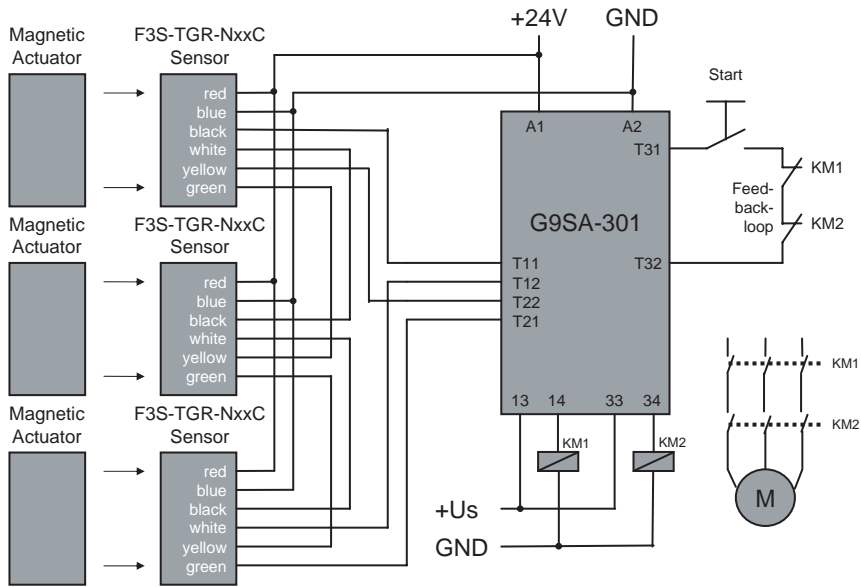

G9SB

Single Sensor Application with G9SB-2002-C

(up to Safety Category 4 acc. EN954-1)

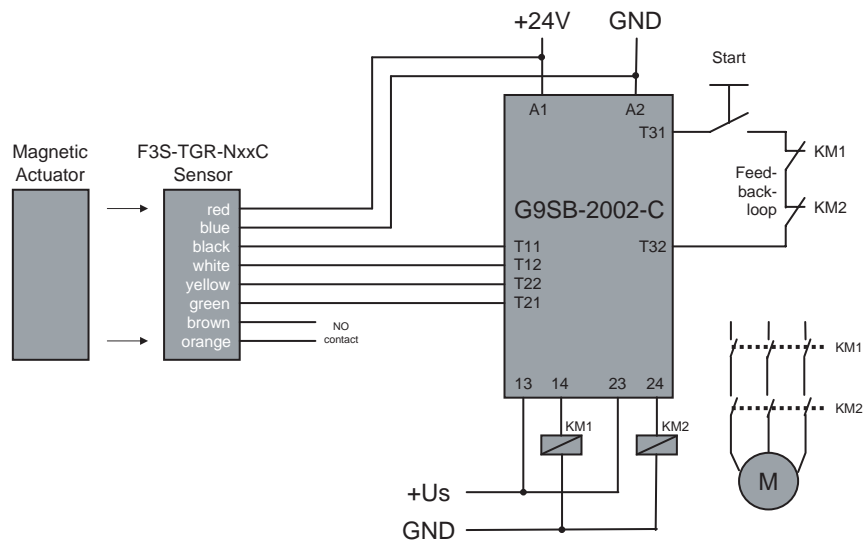

Series connection Application, up to 6 Sensors with G9SB-2002-C

(up to safety Category 3 acc. EN954-1)

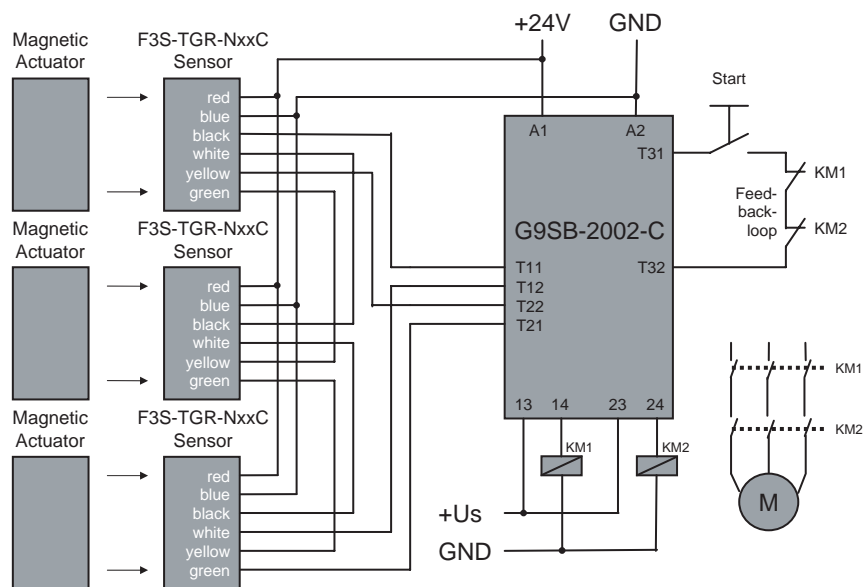

G9SX

Single Sensor Application with G9SX-AD322-T15

(up to Safety Category 4 acc. EN954-1)

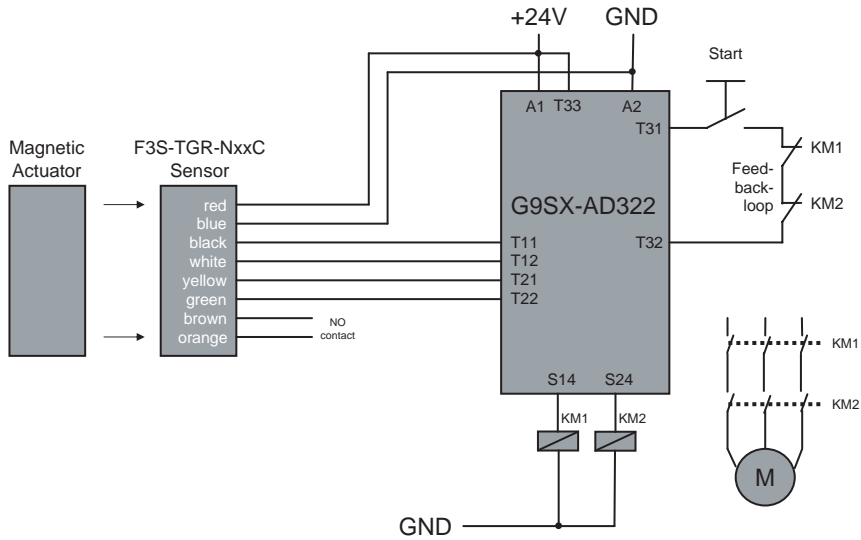

Series connection Application, up to 6 Sensors with G9SX-AD322-T15

(up to Safety Category 3 acc. EN954-1)

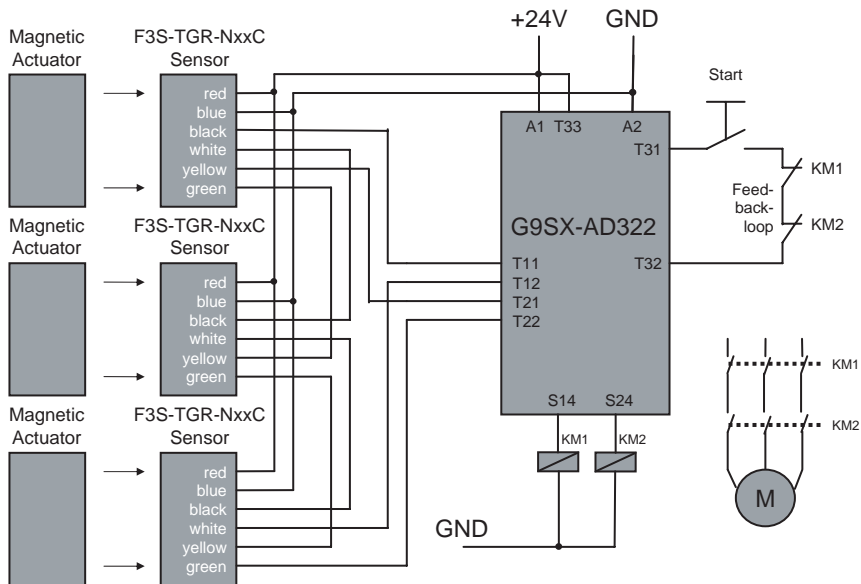

DeviceNet Safety NE1A and DST1-I/O-Terminals

Single Sensor Application with NE1A and DST1-Safety-IO

(up to safety Category 4 acc. EN954-1)

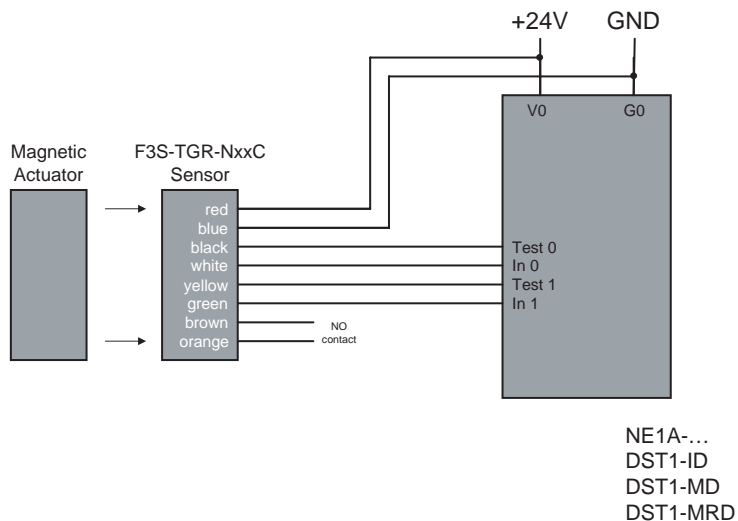

Series connection Application, up to 6 Sensors with NE1A or DST1-Safety-IO

(up to Safety Category 3 acc. EN954-1)

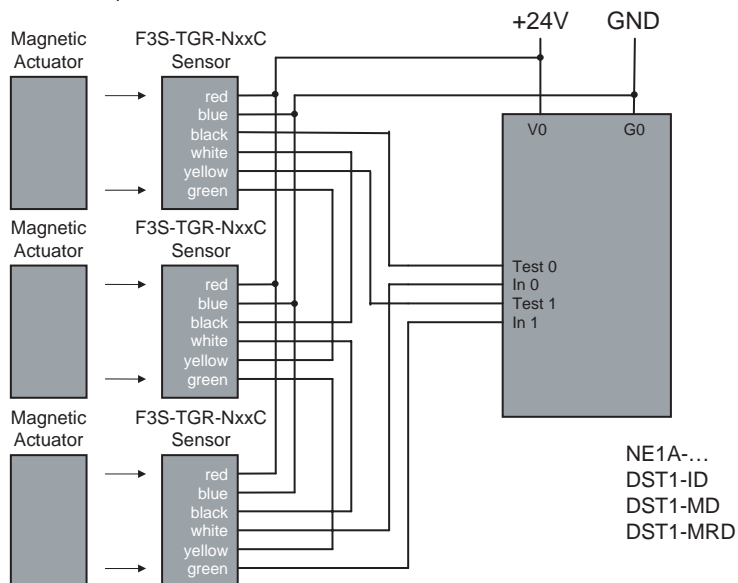

Application with multiple Sensors with NE1A or DST1-Safety-IO

(up to Safety Category 4 acc. EN954-1)

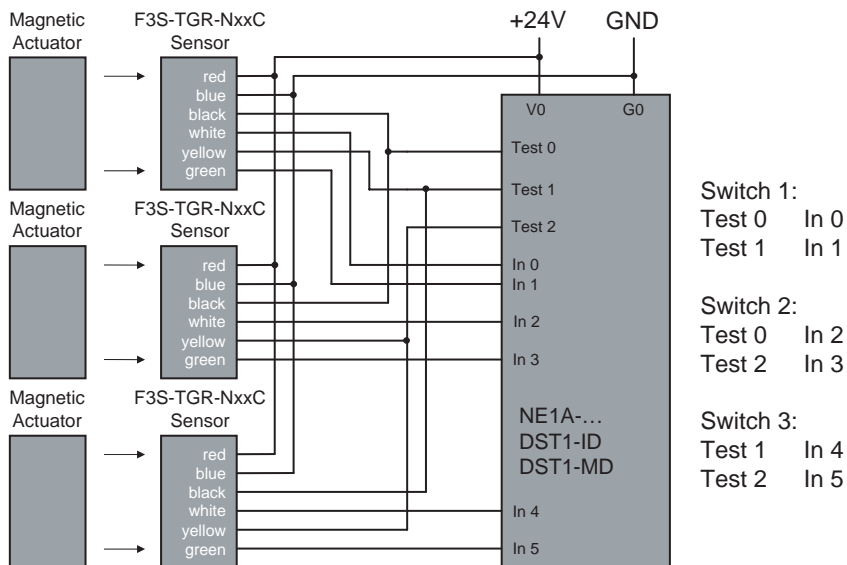

Safety Precautions

WARNING

Be sure to turn OFF the power before performing wiring. Do not touch charge parts (e.g., terminals) while power is ON. Doing so may result in electric shock.



Do not allow the actuator to come close to the switch with the door open. Doing so may cause machinery to start operating and may result in injury.



Keep actuators (magnets) away from magnetically sensitive equipment like PC harddisks, floppy disks etc. The magnetic field of the magnet will damage existing data.

CAUTION

Use guard stops in the way shown below to ensure that the switch and actuator do not make contact when the guard door is closed.

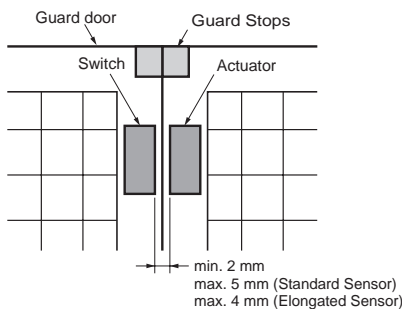

Application Precautions

- Do not use the product in locations subject to explosive or flammable gases.
- Do not use load currents exceeding the rated value.
- Be sure to wire each conductor correctly.
- Be sure to confirm correct operation after completing mounting and adjustment.
- Do not drop or attempt to disassemble the product.
- Be sure to use the correct combination of switch and actuator.
- Use a power supply of the specified voltage. Do not use power supplies with large ripples or power supplies that intermittently generate incorrect voltages.
- Capacitors are consumable and require regular maintenance and inspection.

Precautions for Safe Use

Mounting Direction of Switch and Actuator

The Sensor will not operate properly if the switch and actuator come towards each other diagonally. The Sensor will, however, operate properly if the switch and actuator come towards each other head-on, horizontally or vertically (as long as the faces have the same orientation).

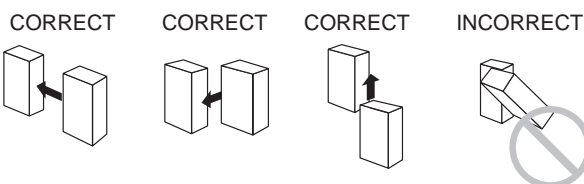
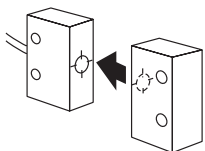

Mutual Interference

If the switch and actuator are mounted in parallel, be sure to separate them by at least 25 mm, as shown below.

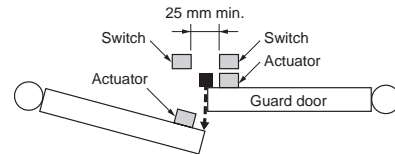

Using for Hinged Doors

On hinged doors, install the Sensor at an opening edge as shown below.

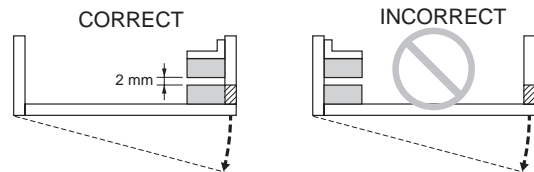

Solvents

Ensure that solvents, such as alcohol, thinner, trichloroethane, or gasoline do not adhere to the product. Solvents may cause markings to fade and components to deteriorate.

Installation Location

Do not install the product in the following locations. Doing so may result in product failure or malfunction.

- Locations subject to direct sunlight
- Locations subject to humidity levels outside the range 35% to 85% or subject to condensation due to extreme temperature changes
- Locations subject to corrosive or flammable gases
- Locations subject to shocks or vibration in excess of the product ratings
- Locations subject to dust (including iron dust) or salts

Take appropriate and sufficient countermeasures when using the product in the following locations.

- Locations subject to static electricity or other forms of noise
- Locations subject to possible exposure to radioactivity
- Locations subject to power supply lines

Wiring

Perform wiring using wire with the following dimensions.

Stranded wire: 2.5 mm²

Solid wire: 4.0 mm²

Tighten the terminal screws with the specified torque. Not doing so may result in malfunction or abnormal heat generation.

Terminal screw tightening torque: 1 N·m



Ph: 03 5278 8222 Fax: 03 5278 9761
65 Douro Street, North Geelong VIC 3215
www.factorycontrols.com.au