

60-m long-distance detection.

This transmissive-type photoelectric sensor for human body detection (Type 4) is ideal for integrated protection of an entire line or multi-sided detection of intrusion into large machines.



- Mutual interference protection function for up to four sets.
- Complies with IEC standards and North American standards (received IEC61496-1, -2, and UL/CSA certification). Can be used as a safety guard for satisfaction of OSHA requirements for on-site labor safety in North America.
- Special controller not needed. Detection of human body intrusion is possible using just the sensor unit.
- Includes “Start/restart interlock function” to prevent automatic reset of output.
- The projector lens and receiver lens are equipped with heaters for worry-free operation even in environments where condensation easily forms.
- Optional glass and stainless steel mirrors are available.

 Be sure to read the “Safety Precautions” on page 8 and the “Precautions for All Safety Sensors”.

Ordering Information

Sensors

Infrared

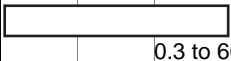
| Sensor type | Appearance | Case material | Connection method | Sensing distance | Output | Model |
|--------------|---|---------------|--|---|------------|------------|
| Through-beam |  | Aluminum | Connected to the terminal block on the internal board. |  0.3 to 60 m | PNP output | F3SS-AT60P |

Note: F3SS-AT60P-L Emitter and F3SS-AT60P-D Receiver can also be ordered individually.

Accessories (Order Separately)

| Item | Model |
|--|----------|
| Laser Alignment Kit (for beam alignment) | F39-LLK |
| Glass Mirror | F39-MSG |
| Stainless Steel Mirror | F39-MSS |
| 45° Mirror Clamp | F39-LM45 |
| Mirror Clamp for Wall Mounting | F39-LA |
| Sensor Clamp for 42-mm-diameter Pipe Stand | F39-LSP |

Note: Wiring is based on a built-in terminal block. Please purchase a 4-mm to 7-mm (dia.) cable separately.

Specifications

| Item | Model | F3SS-AT60P |
|---|-------|--|
| Sensor type | | Through-beam models |
| Safety category | | Category 4, 3, 2, 1, or B |
| Detection capability | | Opaque objects, 31 mm in diameter or greater |
| Lens diameter | | Diameter 36 mm |
| Sensing distance | | 0.3 to 60 m |
| Response time (under stable light incident condition) | | 35 ms max. |
| Startup waiting time | | 4 s or less |
| Power supply voltage (Vs) | | 24 VDC \pm 10% (ripple p-p: 5% max.) |
| Current consumption (no load) | | Emitter: 170 mA max. Receiver: 800 mA max. |
| Light source (emitted wavelength) | | Infrared LED (880 nm) |
| Effective aperture angle (EAA) | | \pm 2.5° at 3 m |
| Control outputs (OSSD) | | Two PNP transistor outputs, load current 250 mA or less (residual voltage 1 V or less) (excluding voltage drop due to cable extension) |
| Output operation mode | | Light-ON |
| Indicators | | Emitter: Power indicator (orange), error mode indicator (red) Receiver: Light intensity level indicator (orange), OFF-state indicator (red), ON-state indicator (green), interlock indicator (yellow) |
| Mutual interference prevention function | | Emitter Frequency Switch |
| Safety functions | | Auto start mode, start interlock mode, and start/restart interlock mode can all be selected using a switch in the receiver. |
| Connection method | | Connected to the terminal block on the internal board. |
| Protective circuits | | Output load short and power supply reverse connection protection |
| Ambient temperature | | Operating/Storage: 0 to 55°C (with no icing or condensation) |
| Ambient humidity | | Operating/Storage: 35% to 95% (with no icing or condensation) |
| Degree of protection | | IEC Standard IP65 |
| Vibration resistance | | Malfunction/destruction: 10 to 55 Hz, amplitude 0.7 mm, 20 sweeps each in X, Y, and Z directions |
| Shock resistance | | Malfunction/destruction: 100 m/s ² , 1,000 times each in X, Y, and Z directions |
| Material | | Aluminum (case and cap) |
| Weight (packed state) | | Approx. 2.5 kg (1 set) |
| Accessories | | Set of mounting clamps, operation manual, caps for conduits |
| Applicable standards | | IEC (EN) 61496-1 Type4 ESPE *1, IEC(prEN)61496-2 Type4 AOPD *2 |

*1. ESPE (Electro-Sensitive Protective Equipment)

*2. AOPD (Active Opto-electronic Protective Devices)

Connections

Wire the F3SS only after all power has been turned off.

Emitter

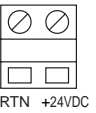
| Terminal block number | Terminal name | Functions | Terminal block assignments |
|-----------------------|---------------|-----------|---|
| J3 | +24 VDC | +24 VDC |  |
| | RTN | 0V (GND) | |

Receiver

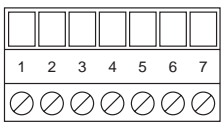
| Terminal block number | Terminal name | Functions | Terminal block assignments |
|-----------------------|---------------|--------------------------------|---|
| J5 | 1 | Control output 1 (+) |  |
| | 2 | For control output 1/2 COM (-) | |
| | 3 | Control output 2 (+) | |
| | 4 | START(-) | |
| | 5 | START(+) | |
| | 6 | +24 VDC | |
| | 7 | 0V (GND) | |

Note: Ground the projector and receiver to the ground terminal inside the case.

Start Interlock or Start/Reset Interlock Mode

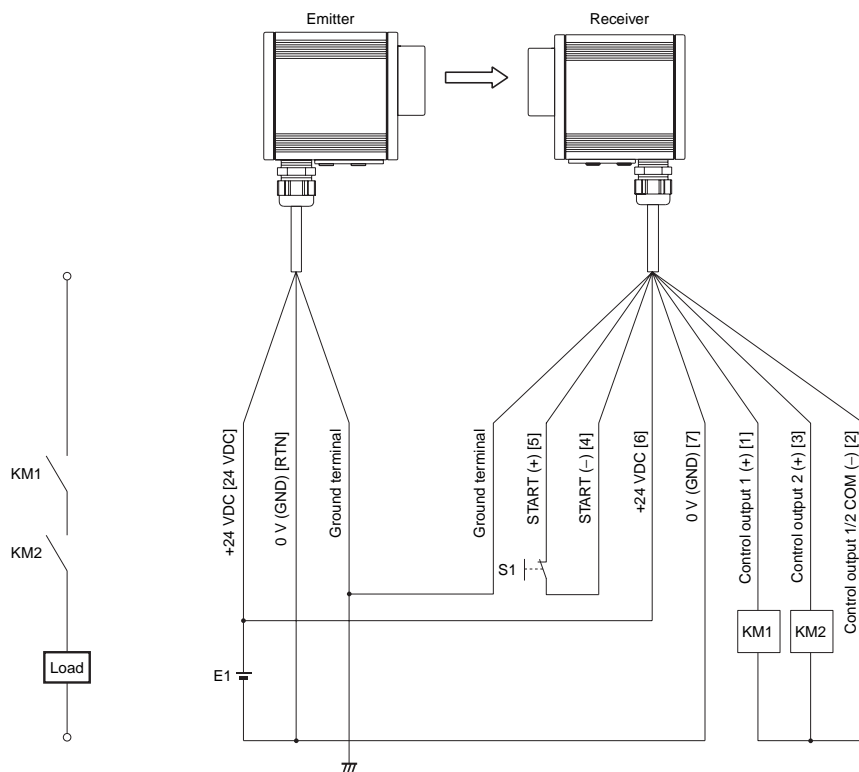

Timing Chart



Terminal names or numbers are given in brackets [].
 E1: 24-VDC power supply (recommended: S82K)
 S1: Start switch (to release interlock): NC contact
 KM1, KM2: DC-driven high-sensitivity contactors (e.g., J7AN)

Auto-start Mode

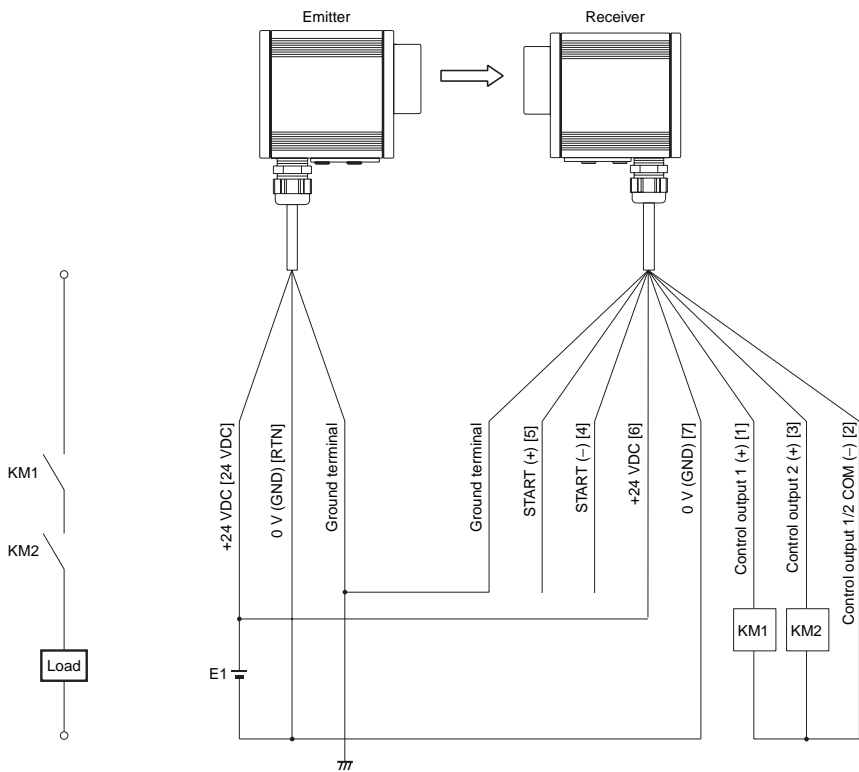

Timing Chart

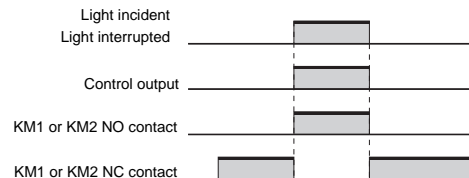

Terminal names or numbers are given in brackets [].
 E1: 24-VDC power supply (recommended: S82K)
 KM1, KM2: DC-driven high-sensitivity contactors (e.g., J7AN)

Connection with OMRON G9SA-301 Safety Relay Unit (Category 4)

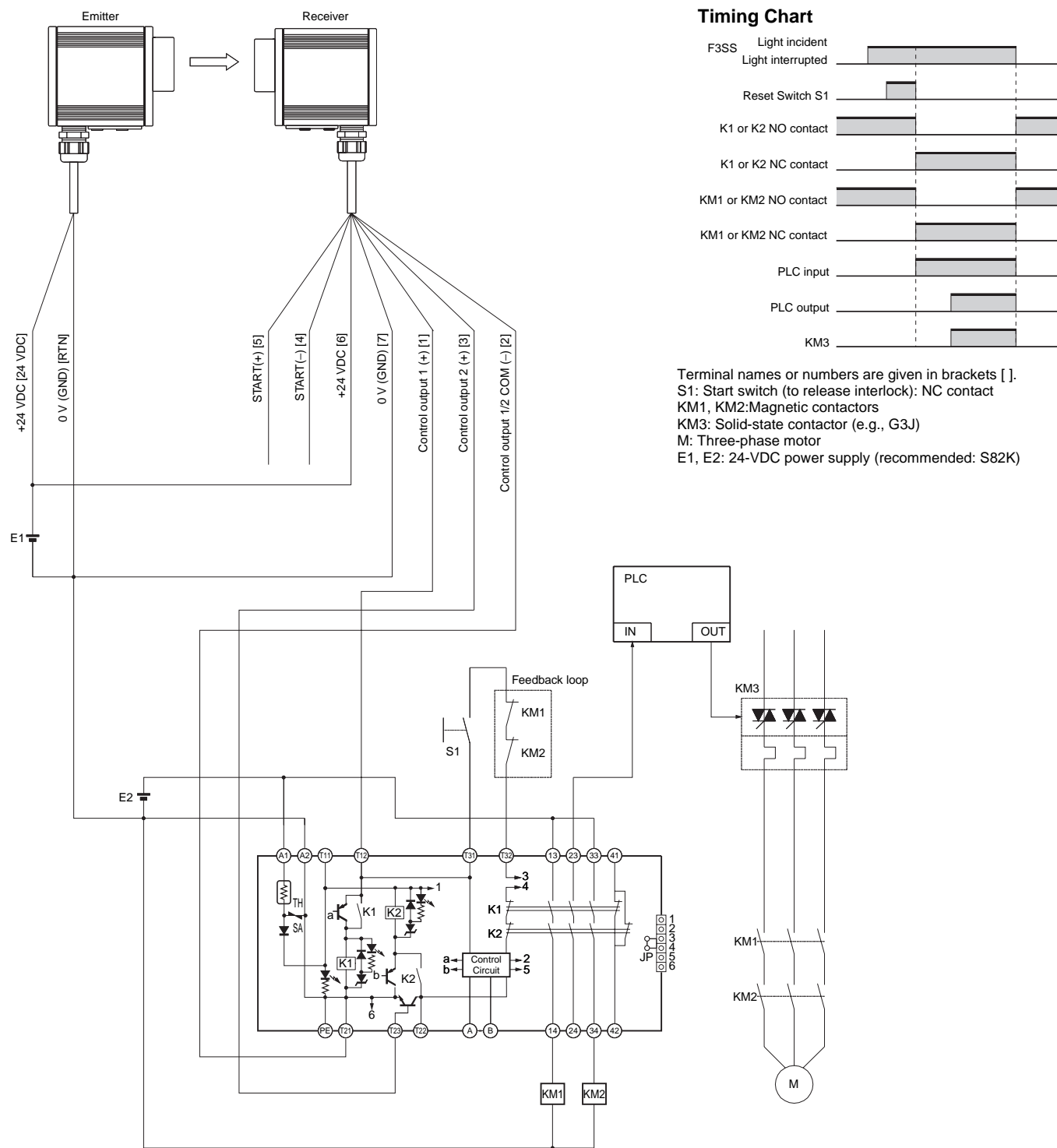

Note: When connecting the F3SS to the G9SA-301, disable the F3SS's start/restart interlock function and use the interlock function in the G9SA-301 instead.

Refer to the *Instruction Manual* included with the product for details.

Dimensions

F3SS-AT60P

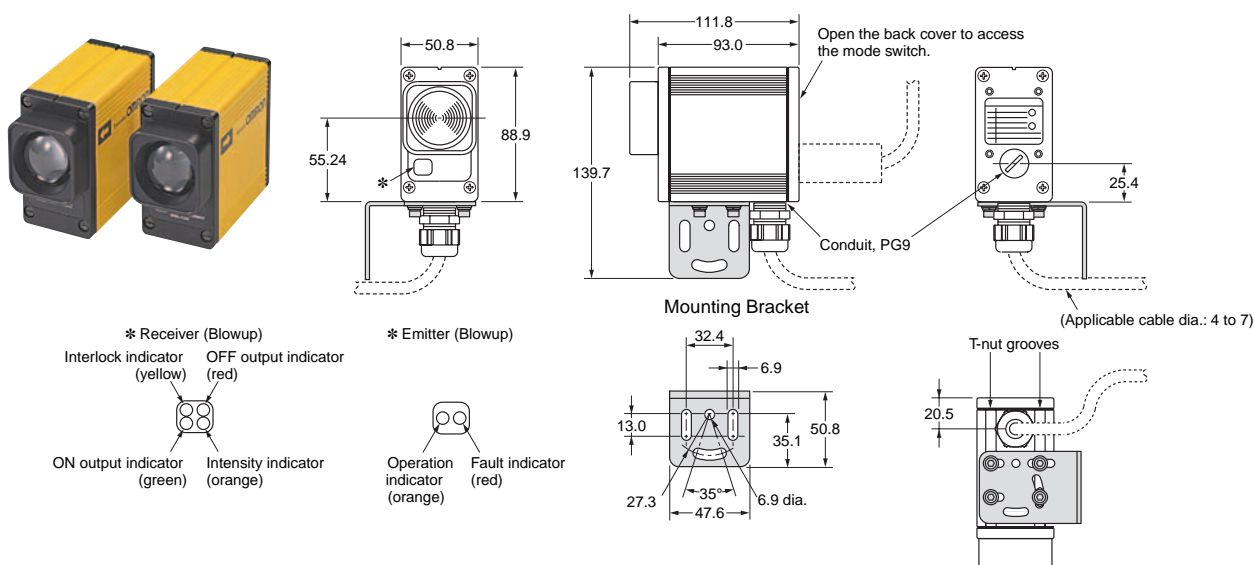

Accessories (Order Separately)

Laser Alignment Kit (for Beam Alignment)

F39-LLK

The Laser Alignment Kit is used to align beams for long detection distances or when using Mirrors in the installation. A Level with a Visible Laser Beam is mounted on top of the Emitter and an Alignment Plate is mounted on the Receiver. First, the built-in levels are used to level the Emitter and Receiver and then the visible laser is turned ON. The heights and angles of the Emitter and Receiver are then adjusted so that the visible laser beam strikes the cross marks on the alignment plate. (Power supply: Three AA batteries, included in the Kit.)

Not Using Mirrors or Using Mirror To Bend Beam Horizontally

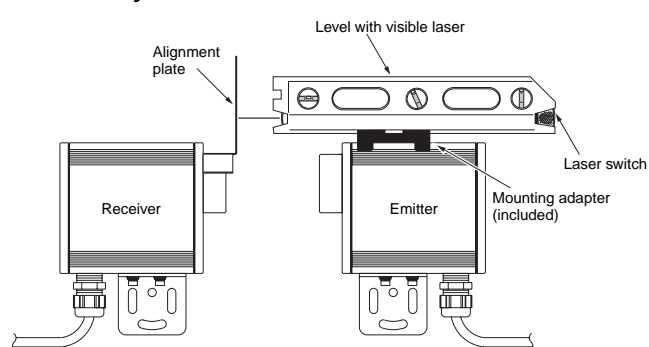

Using Two Mirrors to Bend Beam at a Right Angle

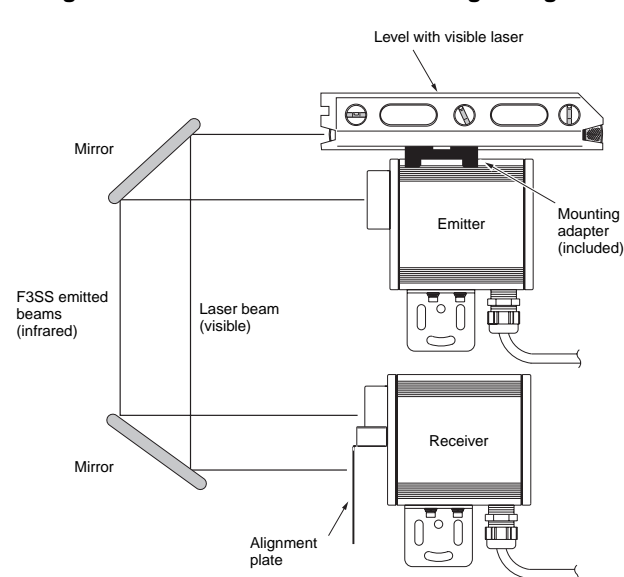

Note: The Laser Alignment Kit includes the alignment plate, level with visible laser, mounting attachment, and three AA batteries.

Glass Mirror
F39-MSG
Stainless Steel Mirror
F39-MSS

These Mirrors are used to bend the beams at 90° angles. Multiple Mirrors can be used to provide protection in two directions or to build a detection system with a 2-beam configuration.

There are two types of Mirror: Glass and Stainless Steel. The reflection rate of the Stainless Steel Mirror is lower, but there is no change of breakage.

The rate of attenuation in the detection distance is 12% for each F39-MSG Glass Mirror and 18% for each F39-MSS Stainless Steel Mirror. The detection distances according to the number of Mirrors used is given in the following table.

| Mirror material | Model | Detection distance (m) vs. No. of mirrors | | | |
|-----------------|---------|---|-----------|-----------|-----------|
| | | 1 Mirror | 2 Mirrors | 3 Mirrors | 4 Mirrors |
| Glass | F39-MSG | 52 | 46 | 40 | 35 |
| Stainless steel | F39-MSS | 49 | 40 | 33 | 27 |

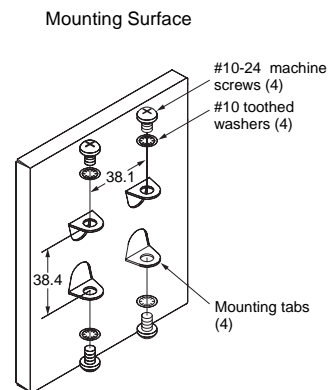
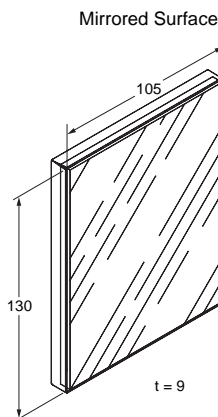

45° Mirror Clamp (for F39-MSG/-MSS)
F39-LM45

Use the F39-LM45 Mirror Clamp when mounting the F39-MSG/-MSS Mirror to a wall or pipe (dia.: 42 ±1). This Clamp enables mounting the Mirror at a 45° angle and bending the beam at a 90° angle.

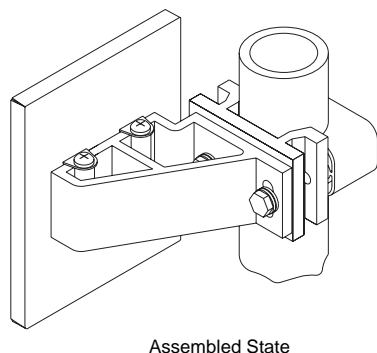
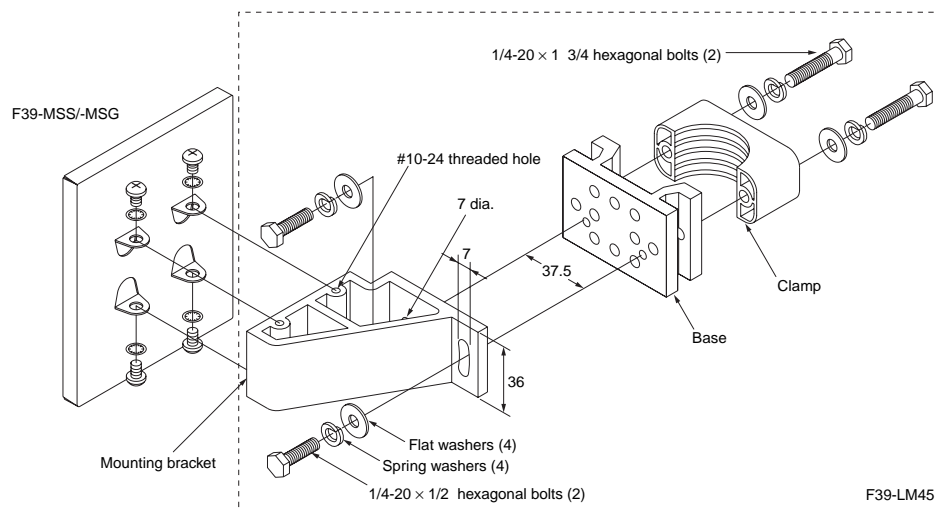

Sensor Clamp for 42-mm-dia. Pipe Stand F39-LSP

This Clamp is used to mount the F3SS Sensor to a pipe with a diameter of 42 ± 1 mm.

F39-LSP (Two Sets of Following Parts)

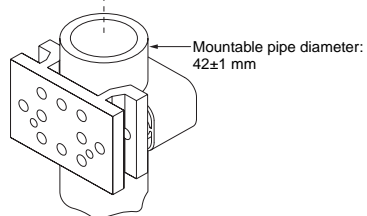
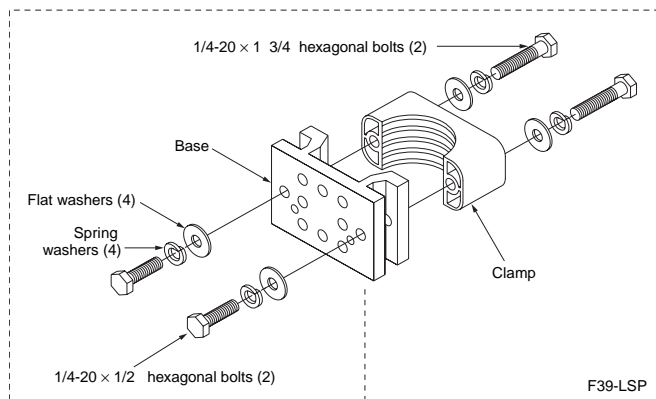

Mounting Method Using Bracket Included with F3SS

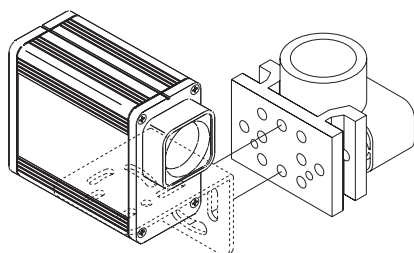

Mirror Clamp for Wall Mounting F39-LA

This Clamp is used to mount the F39-LSP or F39-LM45 to a wall without using a pipe.

F39-LA (Top and Bottom Brackets)

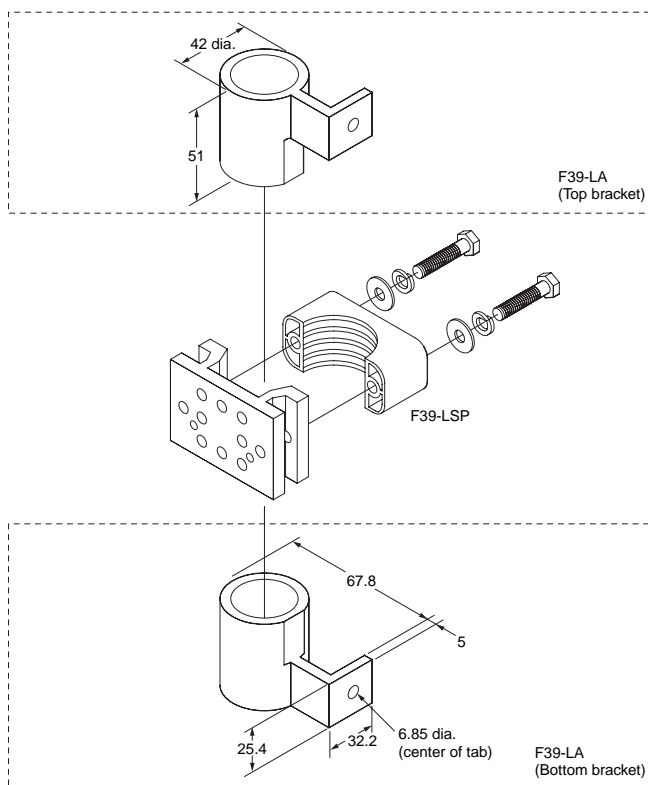

Using the F39-LM45 and F39-LA to Mount the F39-MSS/-MSG Mirror to a Wall

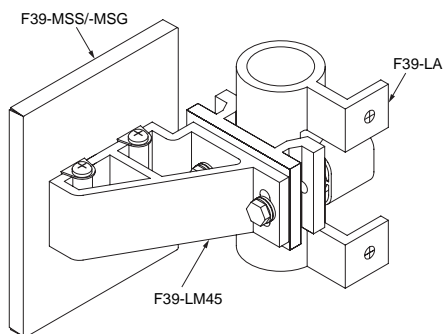

Safety Precautions

Observe the following precautions when using the F3SS.

Regulations and Standards

The F3SS has not received the type certification provided by Article 44-2 of the Industrial Safety and Health Law of Japan. Therefore, it cannot be used in Japan as a safety device for pressing or shearing machines provided by Article 42 of that law.



Safety Distance

Always maintain a safety distance (S) between the F3SS and a hazardous part of a machine.

Failure to do so causes the machine to fail to stop before an operator reaches the dangerous area and may result in serious injury.



Refer to the “*Precautions for All Safety Sensors*” for calculating the Safety distance.

Precautions for Safe Use

Do not use the product in atmospheres or environments that exceed product ratings.

Refer to the *Instruction Manual* for details on installation, connections, and operating methods.

Read and Understand This Catalog

Please read and understand this catalog before purchasing the products. Please consult your OMRON representative if you have any questions or comments.

Warranty and Limitations of Liability

WARRANTY

OMRON's exclusive warranty is that the products are free from defects in materials and workmanship for a period of one year (or other period if specified) from date of sale by OMRON.

OMRON MAKES NO WARRANTY OR REPRESENTATION, EXPRESS OR IMPLIED, REGARDING NON-INFRINGEMENT, MERCHANTABILITY, OR FITNESS FOR PARTICULAR PURPOSE OF THE PRODUCTS. ANY BUYER OR USER ACKNOWLEDGES THAT THE BUYER OR USER ALONE HAS DETERMINED THAT THE PRODUCTS WILL SUITABLY MEET THE REQUIREMENTS OF THEIR INTENDED USE. OMRON DISCLAIMS ALL OTHER WARRANTIES, EXPRESS OR IMPLIED.

LIMITATIONS OF LIABILITY

OMRON SHALL NOT BE RESPONSIBLE FOR SPECIAL, INDIRECT, OR CONSEQUENTIAL DAMAGES, LOSS OF PROFITS OR COMMERCIAL LOSS IN ANY WAY CONNECTED WITH THE PRODUCTS, WHETHER SUCH CLAIM IS BASED ON CONTRACT, WARRANTY, NEGLIGENCE, OR STRICT LIABILITY.

In no event shall the responsibility of OMRON for any act exceed the individual price of the product on which liability is asserted.

IN NO EVENT SHALL OMRON BE RESPONSIBLE FOR WARRANTY, REPAIR, OR OTHER CLAIMS REGARDING THE PRODUCTS UNLESS OMRON'S ANALYSIS CONFIRMS THAT THE PRODUCTS WERE PROPERLY HANDLED, STORED, INSTALLED, AND MAINTAINED AND NOT SUBJECT TO CONTAMINATION, ABUSE, MISUSE, OR INAPPROPRIATE MODIFICATION OR REPAIR.

Application Considerations

SUITABILITY FOR USE

OMRON shall not be responsible for conformity with any standards, codes, or regulations that apply to the combination of products in the customer's application or use of the products.

At the customer's request, OMRON will provide applicable third party certification documents identifying ratings and limitations of use that apply to the products. This information by itself is not sufficient for a complete determination of the suitability of the products in combination with the end product, machine, system, or other application or use.

The following are some examples of applications for which particular attention must be given. This is not intended to be an exhaustive list of all possible uses of the products, nor is it intended to imply that the uses listed may be suitable for the products:

- Outdoor use, uses involving potential chemical contamination or electrical interference, or conditions or uses not described in this catalog.
- Nuclear energy control systems, combustion systems, railroad systems, aviation systems, medical equipment, amusement machines, vehicles, safety equipment, and installations subject to separate industry or government regulations.
- Systems, machines, and equipment that could present a risk to life or property.

Please know and observe all prohibitions of use applicable to the products.

NEVER USE THE PRODUCTS FOR AN APPLICATION INVOLVING SERIOUS RISK TO LIFE OR PROPERTY WITHOUT ENSURING THAT THE SYSTEM AS A WHOLE HAS BEEN DESIGNED TO ADDRESS THE RISKS, AND THAT THE OMRON PRODUCTS ARE PROPERLY RATED AND INSTALLED FOR THE INTENDED USE WITHIN THE OVERALL EQUIPMENT OR SYSTEM.

PROGRAMMABLE PRODUCTS

OMRON shall not be responsible for the user's programming of a programmable product, or any consequence thereof.

Disclaimers

CHANGE IN SPECIFICATIONS

Product specifications and accessories may be changed at any time based on improvements and other reasons.

It is our practice to change model numbers when published ratings or features are changed, or when significant construction changes are made. However, some specifications of the products may be changed without any notice. When in doubt, special model numbers may be assigned to fix or establish key specifications for your application on your request. Please consult with your OMRON representative at any time to confirm actual specifications of purchased products.

DIMENSIONS AND WEIGHTS

Dimensions and weights are nominal and are not to be used for manufacturing purposes, even when tolerances are shown.

PERFORMANCE DATA

Performance data given in this catalog is provided as a guide for the user in determining suitability and does not constitute a warranty. It may represent the result of OMRON's test conditions, and the users must correlate it to actual application requirements. Actual performance is subject to the OMRON Warranty and Limitations of Liability.

ERRORS AND OMISSIONS

The information in this document has been carefully checked and is believed to be accurate; however, no responsibility is assumed for clerical, typographical, or proofreading errors, or omissions.

2008.12

In the interest of product improvement, specifications are subject to change without notice.

OMRON Corporation
Industrial Automation Company

<http://www.ia.omron.com/>

(c)Copyright OMRON Corporation 2008 All Right Reserved.