

Relays Conforming to EN Standard

- Relays with forcibly guided contacts (EN50205 Class A, certified by VDE).
- Supports the CE marking of machinery (Machinery Directive).
- Helps avoid hazardous machine status when used as part of an interlocking circuit.
- Track-mounting and Back-mounting Sockets are available.

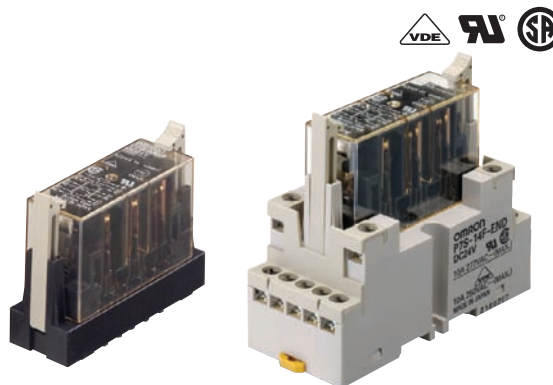

Be sure to read the "Safety Precautions" on page 5 and the "Precautions for All Relays with Forcibly Guided Contacts".

Model Number Structure

Model Number Legend

G7S- A B

1 2

- 1. NO Contact Poles**
4: 4PST-NO
3: 3PST-NO
- 2. NC Contact Poles**
2: DPST-NC
3: 3PST-NC

Ordering Information

Relays with Forcibly Guided Contacts

Type	Poles	Contact configuration	Rated voltage	Model
Standard	6 poles	4PST-NO, DPST-NC	24 VDC	G7S-4A2B
		3PST-NO, 3PST-NC		G7S-3A3B

Sockets

Type		Rated voltage	Model
Track-mounting	Common for track mounting and screw mounting	24 VDC	P7S-14F-END
Back-mounting	PCB terminals	---	P7S-14P-E

Specifications

Ratings

Coil

Rated voltage	Item	Rated current (mA)	Coil resistance (Ω)	Must operate voltage (V)	Must release voltage (V)	Max. voltage (V)	Power consumption (W)
24 VDC		30	800	80% max.	10% min.	110%	Approx. 0.8

- Note:**
1. The rated current and coil resistance are measured at a coil temperature of 23°C with tolerances of $\pm 15\%$.
 2. Performance characteristics are based on a coil temperature of 23°C.
 3. The maximum voltage is based on an ambient operating temperature of 23°C maximum.

Contacts

Item	Load	Resistive load	Inductive load ($\cos \phi = 0.4$, L/R = 7 ms)
Rated load		240 VAC: 3 A, 24 VDC: 3 A	240 VAC: 3 A, 24 VDC: 1 A
Rated carry current		6 A	
Maximum switching voltage		250 VAC, 24 VDC	
Maximum switching current		6 A	

Characteristics of Sockets

Model	Continuous current	Dielectric strength	Insulation resistance
P7S-14□	10 A	2,000 VAC for 1 min. between terminals	1,000 M Ω min. *

Note: Use the P7S-14F-END in the ambient humidity range of 35 to 85%.

* The insulation resistance was measured with a 500-VDC megohmmeter at the same locations as the dielectric strength was measured.

Characteristics

Contact resistance *1		100 m Ω max.
Operating time *2		50 ms max.
Release time *2		50 ms max.
Maximum operating frequency	Mechanical	18,000 operations/h
	Rated load	1,800 operations/h
Insulation resistance *3		100 M Ω min.
Dielectric strength		2,500 VAC, 50/60 Hz for 1 min. (1,500 VAC between contacts of same polarity)
Vibration resistance	Destruction	10 to 55 to 10 Hz, 0.75-mm single amplitude (1.5-mm double amplitude)
	Malfunction	10 to 55 to 10 Hz, 0.375-mm single amplitude (0.75-mm double amplitude)
Shock resistance	Destruction	1,000 m/s ²
	Malfunction	100 m/s ²
Durability *4	Mechanical	10,000,000 operations min. (at approx. 18,000 operations/h)
	Electrical	100,000 operations min. (at the rated load and approx. 1,800 operations/h)
Failure rate (P level) (reference value *5)		5 VDC, 1 mA
Ambient operating temperature		-25 to 70°C (with no icing or condensation)
Ambient operating humidity		5% to 85%
Weight		Approx. 65 g

Note: The above values are initial values.

*1. Measurement conditions: 5 VDC, 10 mA, voltage drops.

*2. Measurement conditions: Rated voltage operation

Ambient operating temperature: 23°C

Contact bounce time is not included.

*3. The insulation resistance was measured with a 500-VDC megohmmeter at the same locations as the dielectric strength was measured.

*4. The durability is for an ambient temperature of 15 to 35°C and an ambient humidity of 25% to 75%.

*5. The failure rate is based on an operating frequency of 60 operations/min.

Engineering Data

Durability Curve (Rated Resistive Load)

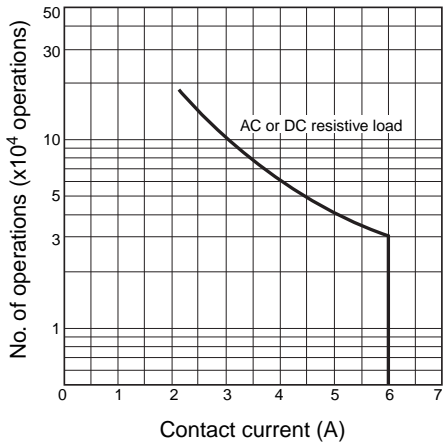

Dimensions

(Unit: mm)

Relays with Forcibly Guided Contacts

G7S-4A2B
G7S-3A3B

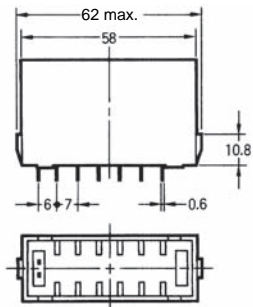
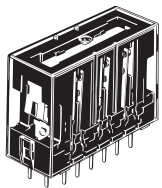

Terminal Arrangement/Internal Connection Diagram (Bottom View) G7S-4A2B

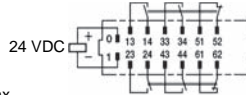

G7S-3A3B

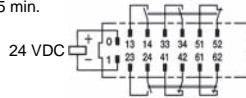

Mounting Hole Dimensions

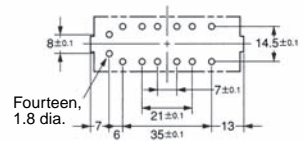

Sockets

Track-mounting Socket
P7S-14F-END

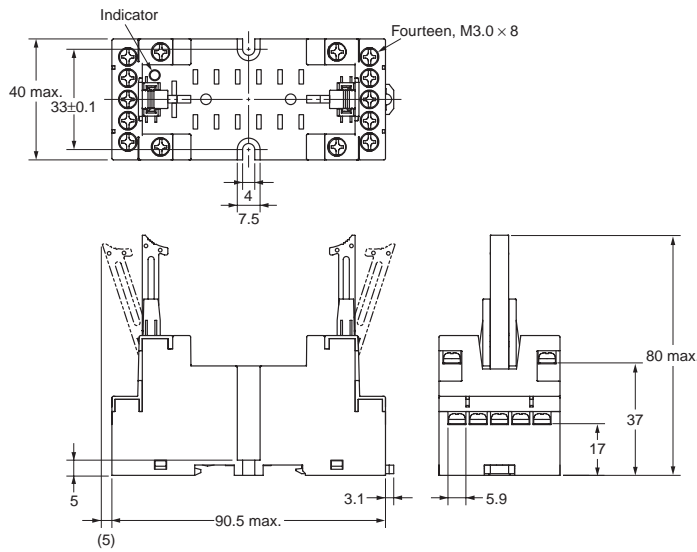
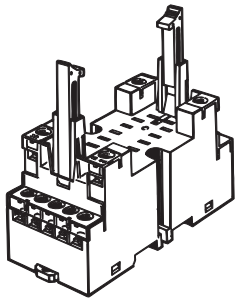

Terminal Arrangement/Internal Connection Diagram (Top View)

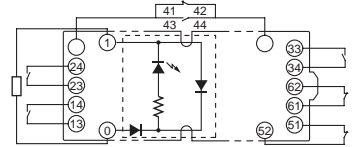

Mounting Hole Dimensions

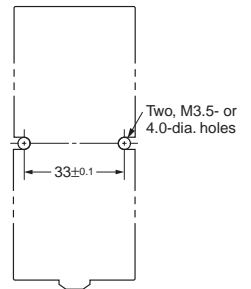

Back-mounting Socket (PCB Terminals)
P7S-14P-E

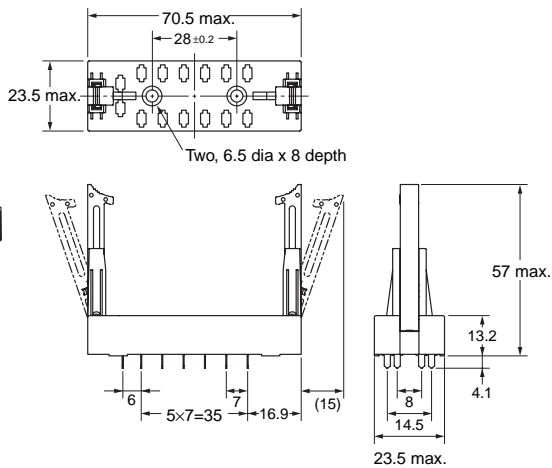
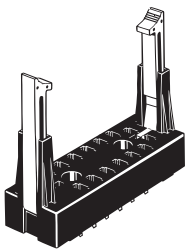

Terminal Arrangement/Internal Connection Diagram (Bottom View) With G7S-4A2B mounted

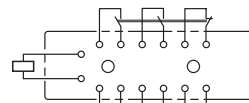

With G7S-3A3B mounted

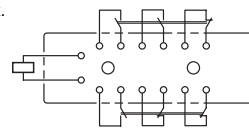

Mounting Hole Dimensions

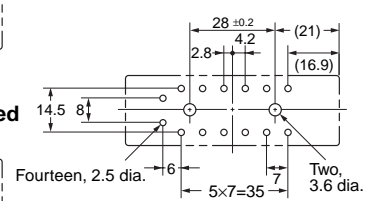

Certified Standards

- EN Standards, VDE Certified
EN61810-1 (Electromechanical non-specified time all-or-nothing relays)
EN50205 (Relays with forcibly guided (linked) contacts)
- UL standard UL508 Industrial Control Devices
- CSA standard CSA C22.2 No. 14 Industrial Control Devices

Forcibly Guided Contacts (from EN50205)

If an NO contact becomes welded, all NC contacts will maintain a minimum distance of 0.5 mm when the coil is not energized. Likewise if an NC contact becomes welded, all NO contacts will maintain a minimum distance of 0.5 mm when the coil is energized.

Safety Precautions

Refer to the *“Precautions for All Relays”* and *“Precautions for All Relays with Forcibly Guided Contacts”*.

Precautions for Correct Use

Wiring

- Use one of the following wires to connect to the P7S-14F-END.
Stranded wire: 0.75 to 1.5 mm²
Solid wire: 1.0 to 1.5 mm²
- Tighten each screw of the P7S-14F-END to a torque of 0.78 to 0.98 N·m.
- Refer to the internal connections diagram of the G9S Safety Relay Unit for an application example of the G7S.
- Wire the terminals correctly with no mistakes in coil polarity, otherwise the G7S will not operate.

Cleaning

The G7S is not of enclosed construction. Therefore, do not wash the G7S with water or detergent.