

- Photoelectric Sensor with built-in amplifier is applicable to a wide variety of lines and ensures a longer sensing distance than any other model.
- User-friendly Sensor takes all installation and on-site conditions into consideration.
- Eliminates the influence of installation and on-site conditions, thus increasing the reliability of the line.
- OMRON has been making efforts towards environmental protection by adopting user and environment-friendly measures.
- Greatly saves energy and resources. The economy-oriented age has evolved into the ecology-oriented age.
- Meets a variety of international standards, thus allowing use in any country.



Ph: 03 5278 8222 Fax: 03 5278 9761
 65 Douro Street, North Geelong VIC 3215
www.factorycontrols.com.au



Ordering Information

List of Models

Red light Infrared light

Sensing method	Appearance	Connection method	Sensing distance	Model	
				NPN output	PNP output
Through-beam		Pre-wired (see note 3)		E3Z-T61	E3Z-T81
		Connector		E3Z-T66	E3Z-T86
Retroreflective (with MSR function)		Pre-wired (see note 3)		E3Z-R61	E3Z-R81
		Connector		E3Z-R66	E3Z-R86
Diffuse-reflective		Pre-wired (see note 3)		E3Z-D61	E3Z-D81
		Connector		E3Z-D66	E3Z-D86
		Pre-wired (see note 3)		E3Z-D62	E3Z-D82
		Connector		E3Z-D67	E3Z-D87

- Note:**
1. The Reflector is sold separately. Select the Reflector model most suited to the application.
 2. The sensing distance specified is possible when the E39-R1S used. Figure in parentheses indicate the minimum required distance between the Sensor and Reflector.
 3. Models provided with a 0.5-m cable are available. When ordering, specify the cable length by adding the code "0.5M" to the model number (e.g., E3Z-T61 0.5M).

Nomenclature

Through-beam Models

E3Z-T6 Receiver

Retroreflective Models

E3Z-R6

Diffuse-reflective Models

E3Z-D6

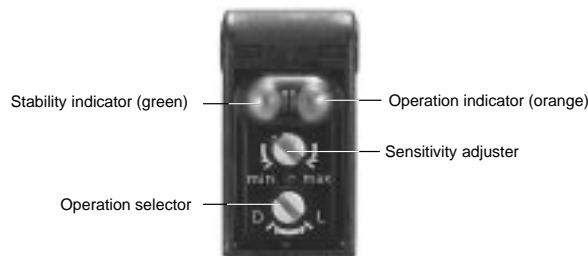

■ Accessories (Order Separately)

Slit for Through-beam Models

Slit width	Sensing distance (typical)	Minimum sensing object (typical)	Model	Quantity required	Remarks
0.5 mm dia.	50 mm	0.5 mm dia.	E39-S65A	One each for the emitter and receiver.	These Slits are available for the E3Z-T□□.
1 mm dia.	200 mm	1 mm dia.	E39-S65B		
2 mm dia.	800 mm	2 mm dia.	E39-S65C		
0.5 × 10 mm	1 m	0.7 mm dia.	E39-S65D		
1 × 10 mm	2.2 m	1.2 mm dia.	E39-S65E		
2 × 10 mm	5 m	2.4 mm dia.	E39-S65F		





Reflectors for Retroreflective Models

Name	Sensing distance (typical)	Model	Remarks
Reflector	3 m (100 mm)	E39-R1	Retroreflective models are not provided with Reflectors. The MSR function is available.
	4 m (100 mm)	E39-R1S	
	5 m (100 mm) (see note 2)	E39-R2	
Miniature Reflector	1.5 m (50 mm) (see note 2)	E39-R3	
Tape Reflector	700 mm (150 mm) (see note 2)	E39-RS1	
	1.1 m (150 mm) (see note 2)	E39-RS2	
	1.4 m (150 mm) (see note 2)	E39-RS3	

Note: 1. Figure in parentheses indicates the minimum required distance between the Sensor and Reflector.



2. The actual sensing distance may be reduced to approximately 70% of the typical sensing distance when using a Reflector other than E39-R1 or E39-R1S.

Mounting Brackets

Appearance	Model	Appearance	Model	Remarks
	E39-L104		E39-L93	For Sensor adjustment use. Mounted to the aluminum frame rails of conveyors and adjustable with ease.
	E39-L43			
	E39-L44			
			E39-L98	Vertical protective cover bracket

Note: If a through-beam model is used, order two Mounting Brackets for the emitter and receiver respectively.

Sensor I/O Connectors

Cable	Appearance	Cable type		Model
Standard	Straight 	2 m	Four-wire type	XS3F-M421-402-A
		5 m		XS3F-M421-405-A
	L-shaped 	2 m		XS3F-M422-402-A
		5 m		XS3F-M422-405-A

Specifications

■ Ratings/Characteristics

Item	Sensing method	Through-beam	Retroreflective with MSR function	Diffuse-reflective	
		E3Z-T61/T66	E3Z-R61/R66	E3Z-D61/D66	E3Z-D62/D67
NPN output					
PNP output (see note 3)		E3Z-T81/T86	E3Z-R81/R86	E3Z-D81/D86	E3Z-D82/D87
Sensing distance		15 m	4 m (100 mm)* (when using E39-R1S) 3 m (100 mm)* (when using E39-R1)	White paper (100 × 100 mm): 100 mm	White paper (300 × 300 mm): 1 m
Standard sensing object		Opaque: 12-mm dia. min.	Opaque: 75-mm dia. min.	---	
Hysteresis		---		20% max. of setting distance	
Directional angle		Both emitter and receiver: 3 to 15°	2 to 10°	---	
Light source (wave length)		Infrared LED (860 nm)	Red LED (680 nm)	Infrared LED (860 nm)	
Power supply voltage		12 to 24 VDC ±10% including 10% (p-p) max. ripple			
Current consumption		Emitter: 15 mA Receiver: 20 mA	30 mA max.		
Control output		Load power supply voltage: 26.4 V max. Load current: 100 mA max. (Residual voltage: 1 V max.) Open collector output (NPN or PNP depending on model) L-ON/D-ON selectable			
Circuit protection		Protection from load short-circuit and reversed power supply connection	Protection from reversed power supply connection, output short-circuit, and mutual interference protection		
Response time		Operation or reset: 1 ms max.			
Sensitivity adjustment		One-turn adjuster			
Ambient illumination (receiver side)		Incandescent lamp: 3,000 lx max. Sunlight: 10,000 lx max.			
Ambient temperature		Operating: -25°C to 55°C/Storage: -40°C to 70°C (with no icing or condensation)			
Ambient humidity		Operating: 35% to 85%/Storage: 35% to 95% (with no condensation)			
Insulation resistance		20 MΩ min. at 500 VDC			
Dielectric strength		1,000 VAC, 50/60 Hz for 1 min			
Vibration resistance		10 to 55 Hz, 1.5-mm double amplitude or 300 m/s ² for 2 hours each in X, Y, and Z directions			
Shock resistance		Destruction: 500 m/s ² 3 times each in X, Y, and Z directions			
Degree of protection		IP67 (IEC60529)			
Connection method		500-mm-thick pre-wired cable (standard length: 2 m) with M8 connector			
Indicator		Operation indicator (orange) Stability indicator (green) Emitter has power indicator (orange) only.			
Weight (packed state)	Pre-wired cable (2 m)	Approx. 120 g	Approx. 65 g		
	Connector	Approx. 30 g	Approx. 20 g		
Material	Case	PBT (polybutylene terephthalate)			
	Lens	Methacrylate resin			
Accessories		Instruction manual (The Reflector or Mounting Bracket is not provided with any of the above models.)			

Note: *Figures in parentheses indicate the minimum required distances between the Sensors and Reflectors.

Engineering Data

Parallel Operating Range (Typical)

Through-beam Models
E3Z-T□1 (T□6)

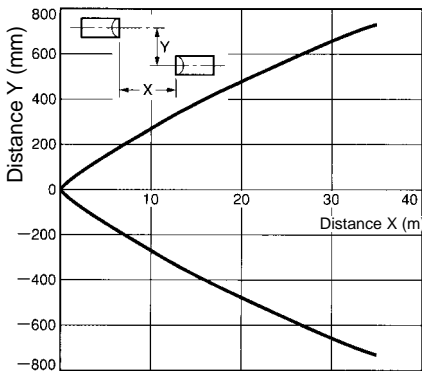

Through-beam Models
E3Z-T□1 (T□6) and Slit

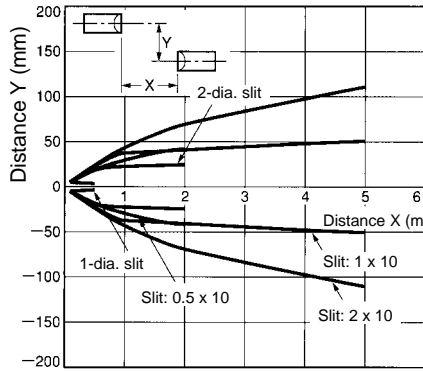

Retroreflective Models
E3Z-R□1 (R□6) and Reflector

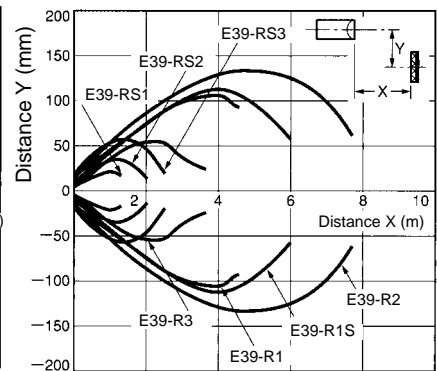

Operating Range (Typical)

Diffuse-reflective Models
E3Z-D□1 (D□6)

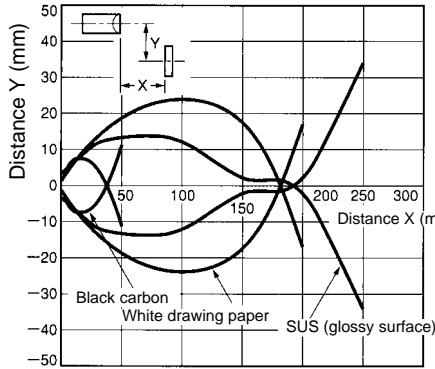

Diffuse-reflective Models
E3Z-D□2 (D□7)

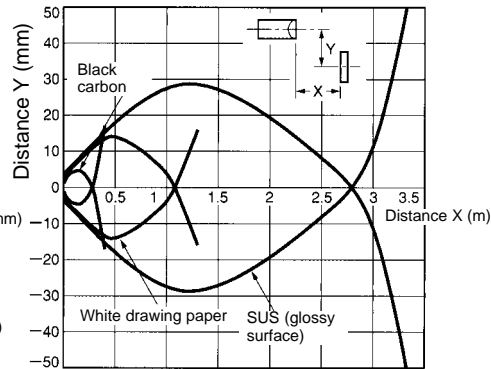

■ Excess Gain Ratio vs. Distance (Typical)

Through-beam Models

E3Z-T□1 (T□6)

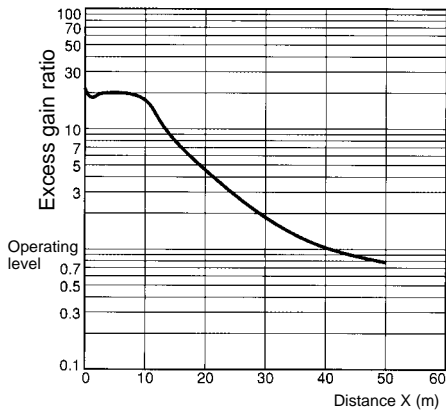

Retroreflective Models

E3Z-R□1 (R□6) and Reflector

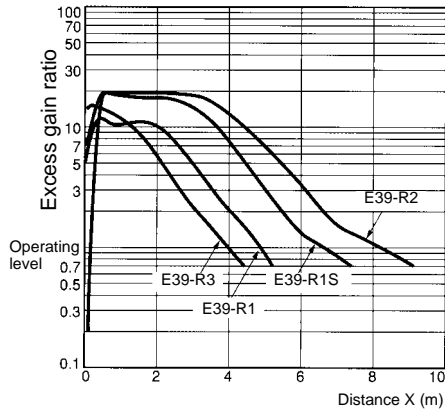

Diffuse-reflective Models

E3Z-D□1 (D□6)

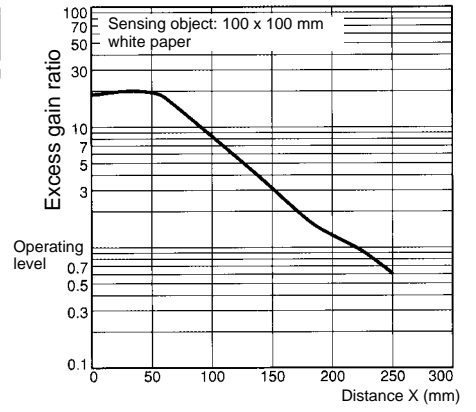

Diffuse-reflective Model

E3Z-D□2 (D□7)

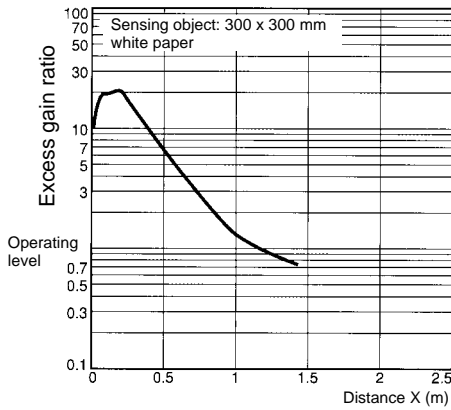

■ Sensing Object Size vs. Sensing Distance (Typical)

Diffuse-reflective Models

E3Z-D□1 (D□6)

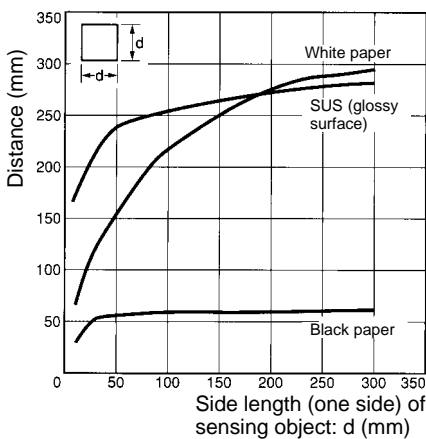

Diffuse-reflective Models

E3Z-D□2 (D□7)

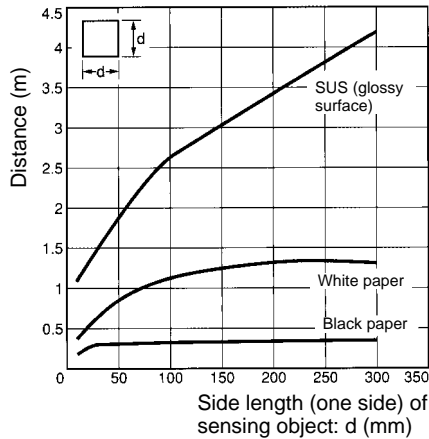

Operation

NPN Output

Model	E3Z-T61/-T66/-R61/-R66/-D61/-D66/-D62/-D67	
Output transistor status	Light ON	Dark ON
Timing chart		
Mode selector	Light ON (L/ON)	Dark ON (D/ON)
Output circuit	<p style="text-align: center;">Connector Pin Arrangement</p> <p style="text-align: center;">Pin 2 is open.</p>	
	<p style="text-align: center;">Through-beam emitter</p> <p style="text-align: center;">Connector Pin Arrangement</p> <p style="text-align: center;">Pins 2, 4 are open.</p>	

PNP Output

Model	E3Z-T81/-T86/-R81/-R86/-D81/-D86/-D82/-D87	
Output transistor status	Light ON	Dark ON
Timing chart		
Mode selector	Light ON (L/ON)	Dark ON (D/ON)
Output circuit	<p style="text-align: center;">Connector Pin Arrangement</p> <p style="text-align: center;">Pin 2 is open.</p>	
	<p style="text-align: center;">Through-beam emitter</p> <p style="text-align: center;">Connector Pin Arrangement</p> <p style="text-align: center;">Pins 2, 4 are open.</p>	

Structure of Sensor I/O Connector

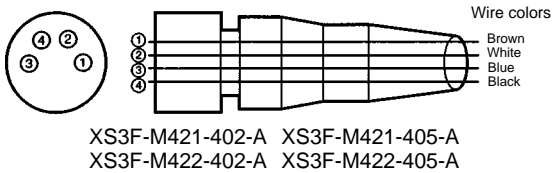

Classification	Wire color	Connector pin No.	Use
DC	Brown	①	Power supply (+V)
	White	②	---
	Blue	③	Power supply (0 V)
	Black	④	Output

Note: Pin 2 is not used.

Dimensions

Note: All units are in millimeters unless otherwise indicated.

■ Sensors

Through-beam (Pre-wired Models)

E3Z-T61
E3Z-T81

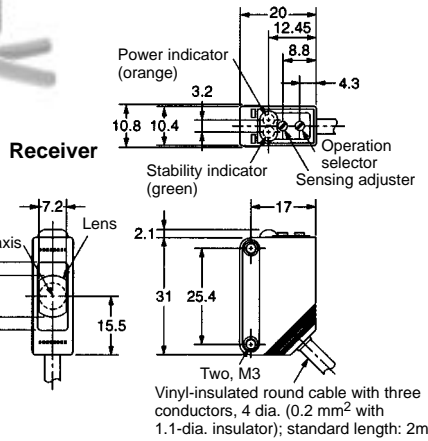
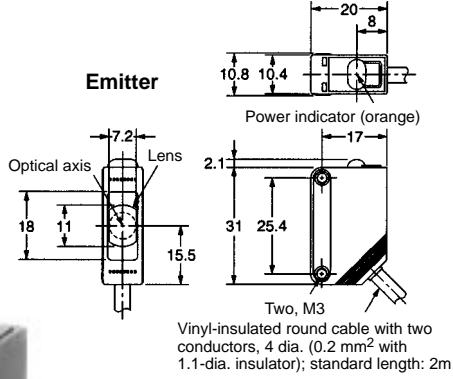

Through-beam (Connector Models)

E3Z-T66
E3Z-T86

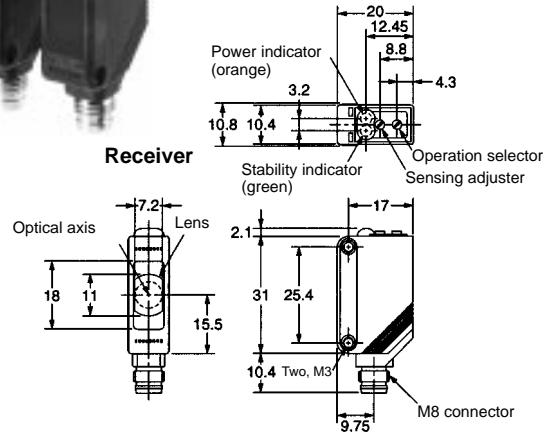
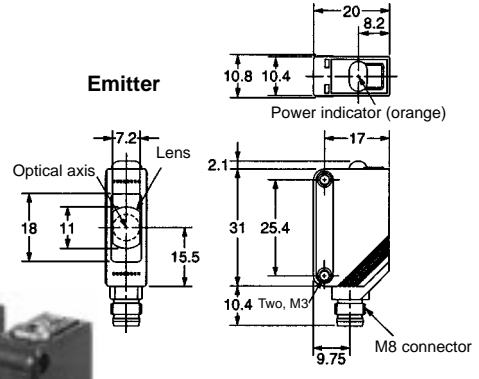

Retroreflective Models (Pre-wired Models)

E3Z-R61
E3Z-R81

Diffuse-reflective Models

E3Z-D61
E3Z-D62
E3Z-D81
E3Z-D82

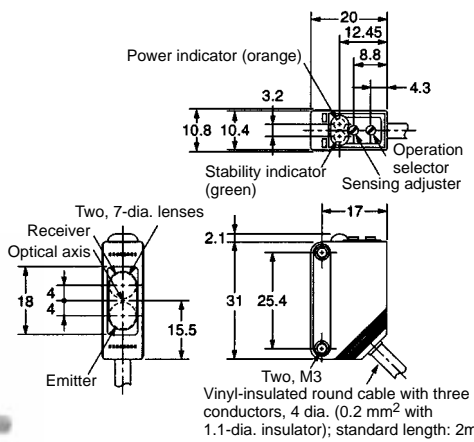

Retroreflective Models (Connector Models)

E3Z-R66
E3Z-R86

Diffuse-reflective Models

E3Z-D66
E3Z-D67
E3Z-D86
E3Z-D87

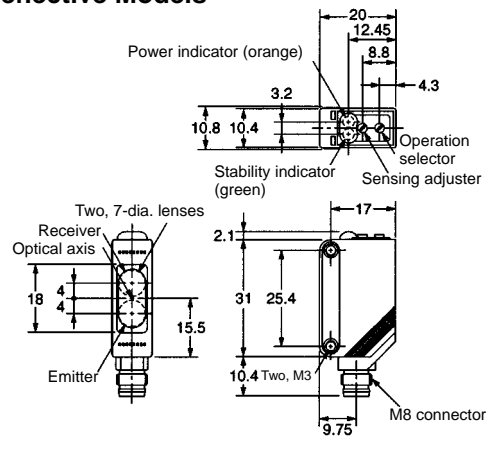

■ Accessories (Order Separately)

Slits

E39-S65A
E39-S65B
E39-S65C

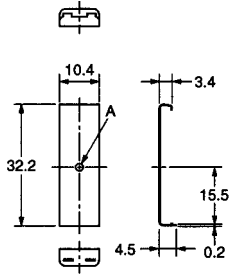

Model	Side A	Material
E39-S65A	0.5 dia.	SUS301 stainless steel
E39-S65B	1.0 dia.	
E39-S65C	2.0 dia.	

E39-S65D
E39-S65E
E39-S65F

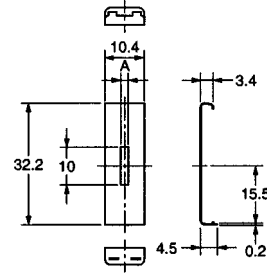

Model	Side A	Material
E39-S65D	0.5	SUS301 stainless steel
E39-S65E	1.0	
E39-S65F	2.0	

Reflectors

E39-R1
E39-R1S

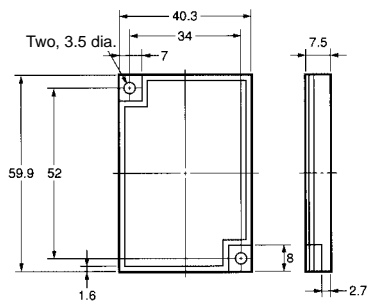
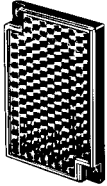

Material
Surface: Acrylic resin
Backside: ABS resin

E39-R2

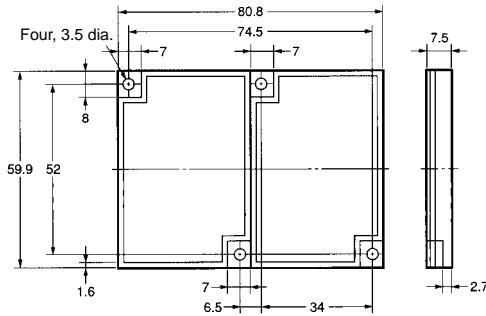
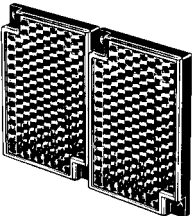

Material
Surface: Acrylic resin
Backside: ABS resin

Miniature Reflector

E39-R3



Material
Surface: Acrylic resin
Backside: ABS resin

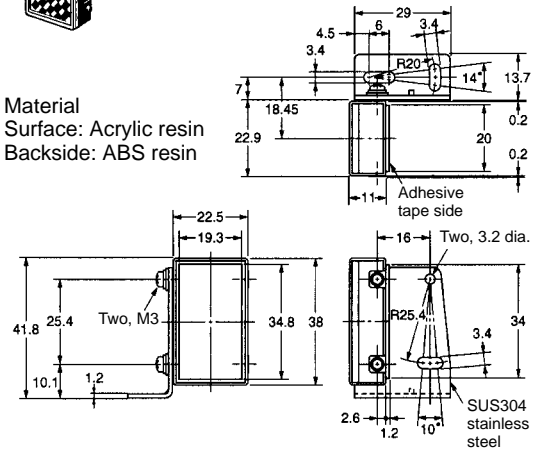

Tape Reflectors

E39-RS1

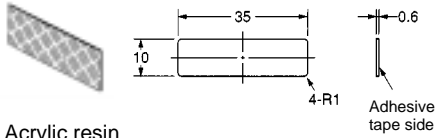

Material: Acrylic resin

E39-RS2

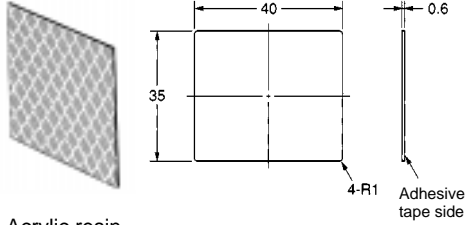

Material: Acrylic resin

E39-RS3

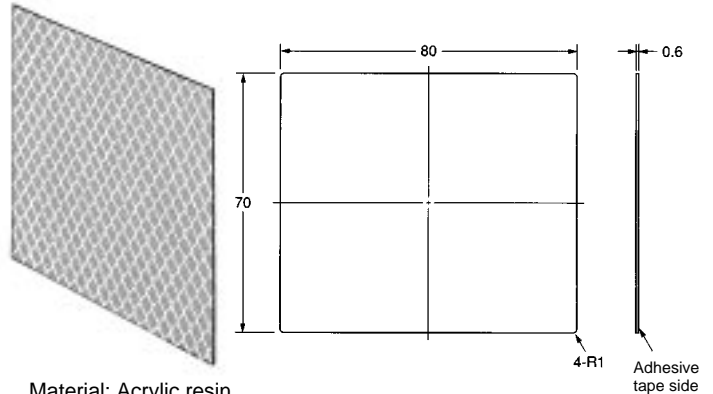

Material: Acrylic resin

Mounting Brackets

E39-L104

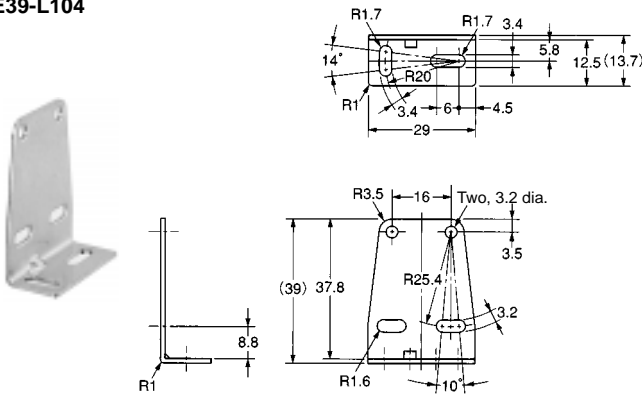

Material: SUS304 stainless steel

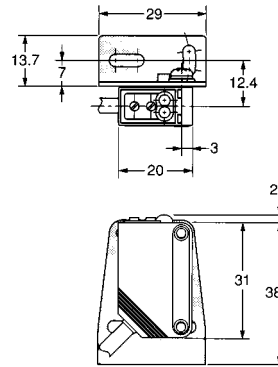

With Mounting Bracket (E3Z-D62)

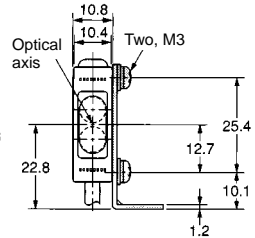

E39-L43

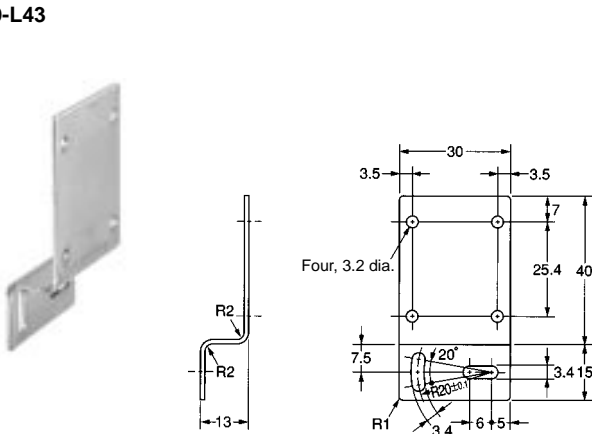

Material: SUS304 stainless steel

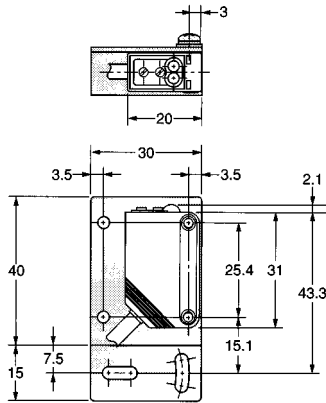

With Mounting Bracket (E3Z-D62)

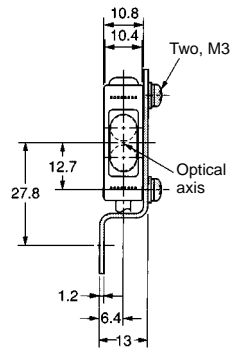

E39-L44

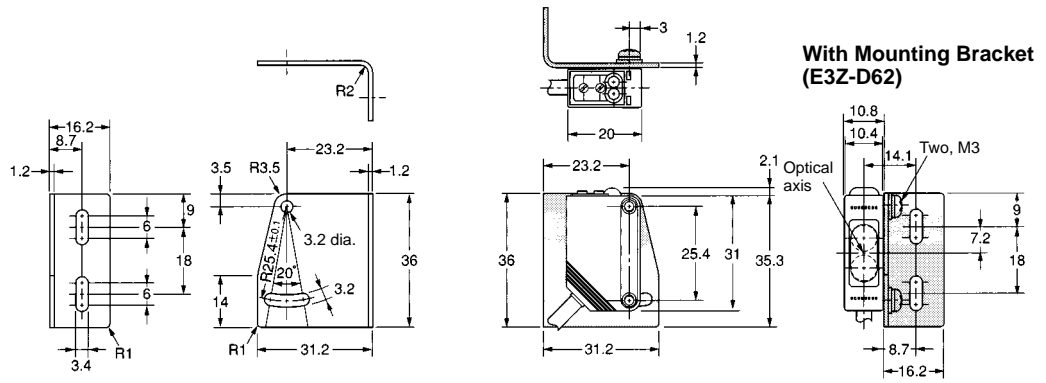

Material: SUS304 stainless steel

E39-L93

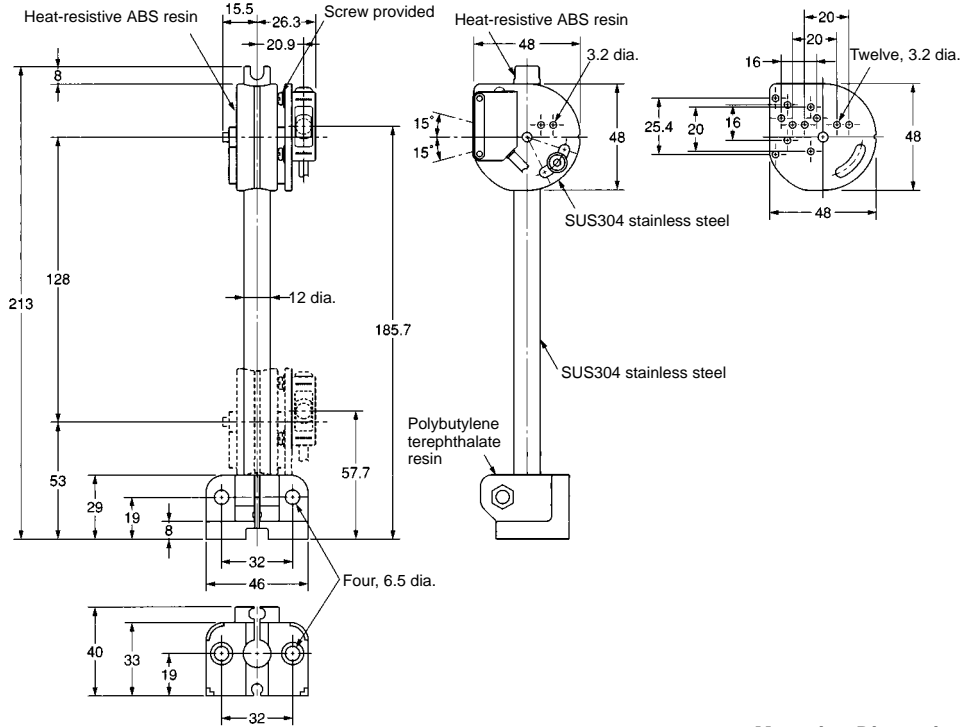

E39-L98

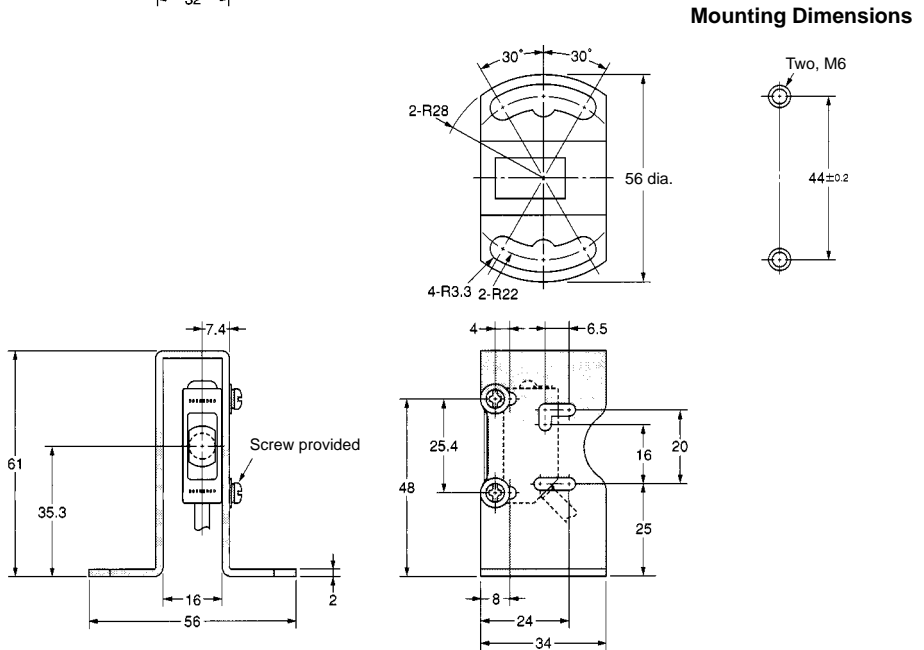

Material: SUS304 stainless steel

Sensor I/O Connectors

Straight

XS3F-M421-402-A (L=2 m)
XS3F-M421-405-A (L=5 m)

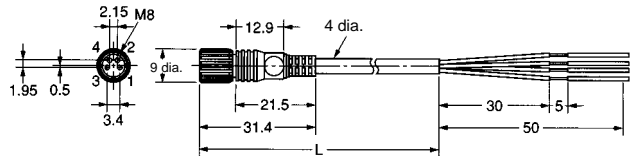

L-shaped

XS3F-M422-402-A (L=2 m)
XS3F-M422-405-A (L=5 m)

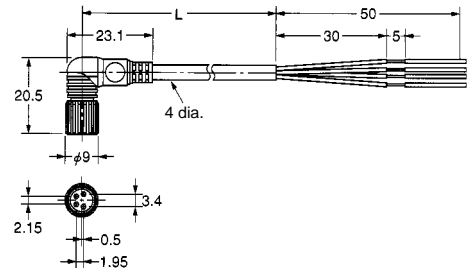

Precautions

Be sure to abide by the following precautions for the safe operation of the Sensor.

Wiring

Power Supply Voltage

Make sure that the power supply to the Sensor is within the rated voltage range and do not apply 100 VAC or more if the Sensor is a DC model, or otherwise the Sensor may explode or burn.

Load Short-circuiting

Do not short-circuit the load, otherwise the Sensor may be damaged.

■ Correct Use

Settings

Power Reset Time

The Sensor is ready to operate 100 ms after the Sensor is turned ON. If the load and Sensor are connected to independent power supplies respectively, be sure to turn ON the Sensor before turning the load ON.

Connections

M8 Metal Connector

- Be sure to connect or disconnect the metal connector after turning OFF the Sensor.
- Hold the connector cover to connect or disconnect the metal connector.
- Secure the connector cover by hand. Do not use any pliers, otherwise the connector may be damaged.
- The proper tightening torque range is between 0.3 and 0.4 N • m. Be sure to tighten the connector securely, otherwise the specified degree of protection may not be maintained or the connector may be disconnected due to vibration.

Wiring Mistakes

Do not make mistakes in wiring, such as mistakes in polarity, otherwise the Sensor may be damaged.

Connection without Load

Do not connect power supply to the Sensor with no load connected, otherwise the internal elements may explode or burn.

Operating Environment

Do not use the Sensor in locations with explosive or flammable gas.

Mounting

Sensor Mounting

Use M3 screws to mount the sensor and tighten each screw to a maximum torque of 0.53 N • m.

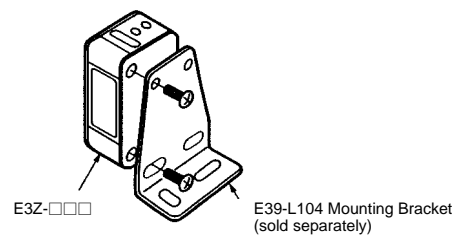

Adjustment

**Slits for Through-beam Models
(E39-S65A/B/C/D/E/F (Sold Separately))**

<p>Mounting method</p> <ol style="list-style-type: none"> 1. Hook the upper protruding portion of the Slit to the upper indented mounting portion of the Sensor and adjust the position of the Slit so that the Slit will be in parallel to the lens side of the Sensor. 2. Press the lower protruding portion of the Slit onto the indented mounting portion of the Sensor until the Slit snaps in. 	
<p>Mounting condition</p>	<p>Side view Front view</p>
<p>Removal method</p> <ol style="list-style-type: none"> 1. Press the upper portion of the Slit. 2. Disconnect the lower protruding portion of the Slit from the Sensor and remove the Slit. 	

ALL DIMENSIONS SHOWN ARE IN MILLIMETERS.
To convert millimeters into inches, multiply by 0.03937. To convert grams into ounces, multiply by 0.03527.

Cat. No. E308-E1-1 In the interest of product improvement, specifications are subject to change without notice.

OMRON Corporation
Industrial Automation Company

Industrial Sensors Division
Sensing Devices and Components Division H.Q.
28th Fl., Crystal Tower Bldg.,
1-2-27, Shiromi, Chuo-ku,
Osaka 540-6028 Japan
Phone: (81)6-6949-6012 Fax: (81)6-6949-6021



Ph: 03 5278 8222 Fax: 03 5278 9761
65 Douro Street, North Geelong VIC 3215
www.factorycontrols.com.au

Printed in Japan
0799-5M (0799) ④