

- Switching between background and foreground suppression (BGS/FGS) enables detecting a variety of objects under various background/foreground conditions.
- Influence of external interference, including inverter fluorescent lighting, minimized with unique avoidance algorithm.
- Red beam for easy spot position confirmation.
- Almost no differences in detection distances for different colors.
- Minimal hysteresis to enable detecting small steps (2/3 of previous models: E3S-LS20□4S).
- Same compact size as the E3Z Series: Use the same Mounting Brackets.



Ordering Information

■ Sensors

Sensing method	Appearance	Connection method	Sensing distance (white paper)	Model	
				NPN output	PNP output
Distance-settable		Pre-wired (2-m cable) (See note.)		E3Z-LS61	E3Z-LS81
		M8 Connector		E3Z-LS66	E3Z-LS86

Note: Models are also available with 0.5-m cables. Specify the cable length after the model number (example: E3Z-LS61 0.5M).

■ Accessories (Order Separately)

Sensor I/O Connectors

Cable specification	Appearance	Cable type		Model
		Length	Wires	
Standard M8 cable	Straight	2 m	4-wire	XS3F-M421-402-A
		5 m		XS3F-M421-405-A
	L-shaped	2 m		XS3F-M422-402-A
		5 m		XS3F-M422-405-A

Note: Refer to page 11 for details on Mounting Brackets.

Application Example

Simple Detection of Glossy, Uneven Objects

BGS (Background Suppression)

Selectable by Changing Cable Connection

FGS (Foreground Suppression)

Objects beyond the set distance, such as the conveyor, will not be detected. The hysteresis is 10% or less, so at a set distance of 40 mm, steps with a thickness of 4 mm can be detected on objects.

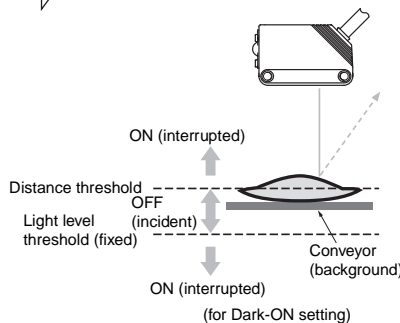
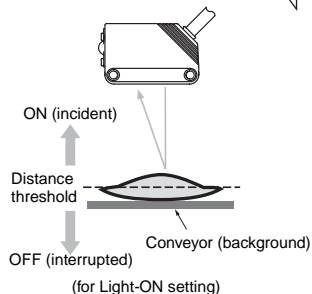

Glossy, uneven objects are reliably detected because the OFF (incident) status occurs only when the conveyor is detected, and ON (interrupted) status occurs only when an object exists or when reflected light is not returned to the Sensor. (Depending on the shape of the object, an OFF-delay timer may be required.)

Specifications

■ Ratings/Characteristics

Item	Sensing method		Distance-settable	
	NPN output	E3Z-LS61		E3Z-LS66
	PNP output	E3Z-LS81		E3Z-LS86
Sensing distance	BGS	White or black paper (100 x 100 mm): 20 mm to set distance		
	FGS	White paper (100 x 100 mm): Set distance to 200 mm min. Black paper (100 x 100 mm): Set distance to 160 mm min.		
Setting range	White paper (100 x 100 mm): 40 to 200 mm Black paper (100 x 100 mm): 40 to 160 mm			
Hysteresis	10% of set distance max. (Refer to <i>Hysteresis vs. Sensing Distance</i> on page 4.)			
Reflectivity characteristic (black/white error)	10% of set distance max.			
Light source (wavelength)	Red LED (680 nm)			
Power supply voltage	12 to 24 VDC \pm 10%, ripple (p-p) 10% max.			
Current consumption	30 mA max.			
Control output	Load power supply voltage 26.4 VDC max., load current 100 mA max. (residual voltage 1 V max.) Open collector output (NPN or PNP depending on model) Light-ON/Dark-ON switch selectable			
BGS/FGS selection	BGS: Open or connected to GND FGS: Connected to Vcc			
Protective circuits	Reverse polarity protection, output short-circuit protection, mutual interference prevention			
Response time	Operation or reset: 1 ms max.			
Distance setting	5-turn endless adjuster			
Ambient illumination	Incandescent lamp: 3,000 lx max.; Sunlight: 10,000 lx max.			
Ambient temperature	Operating: -25 to 55°C , Storage: -40 to 70°C (with no icing or condensation)			
Ambient humidity	Operating: 35% to 85%, Storage: 35% to 95% (with no condensation)			
Insulation resistance	20 M Ω min. at 500 VDC			
Dielectric strength	1,000 VAC at 50/60 Hz for 1 minute			
Vibration resistance (destruction)	10 to 55 Hz, 1.5-mm double amplitude for 2 hours each in X, Y, and Z directions			
Shock resistance (destruction)	500 m/s ² for 3 times each in X, Y, and Z directions			
Degree of protection	IEC 60529 IP67			
Connection method	Pre-wired (standard length: 2 m/0.5 m)		M8 connector	
Indicators	Operation indicator (orange), stability indicator (green)			
Weight (packed state)	Pre-wired Sensors, 2 m: Approx. 65 g		Approx. 20 g	
Material	Case	PBT (polybutylene terephthalate)		
	Lens	Denaturated polyallylate		
Accessories	Instruction sheet (Mounting Brackets must be purchased separately.)			

Engineering Data

Operating Range

BGS

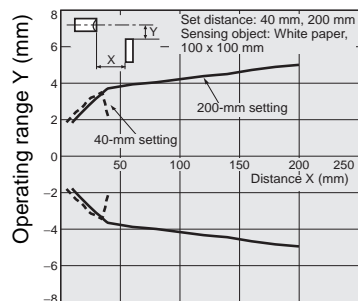

FGS

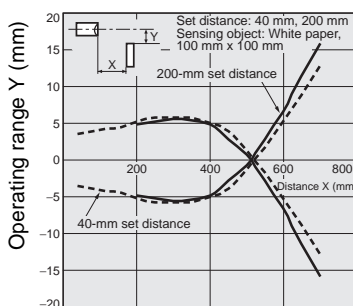

Spot Diameter vs. Sensing Distance

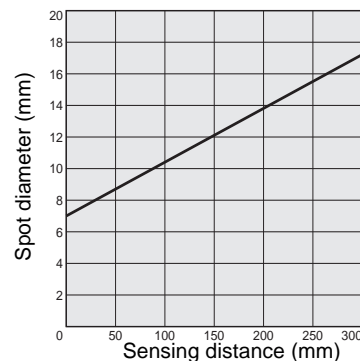

Inclination Characteristics

Vertical

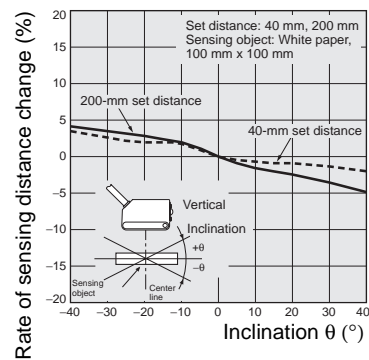

Horizontal

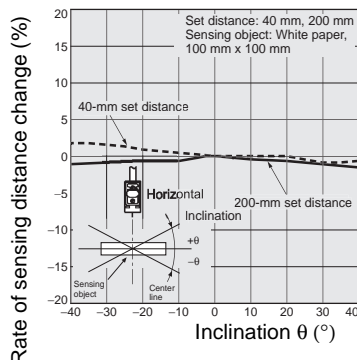

Short-distance Characteristic

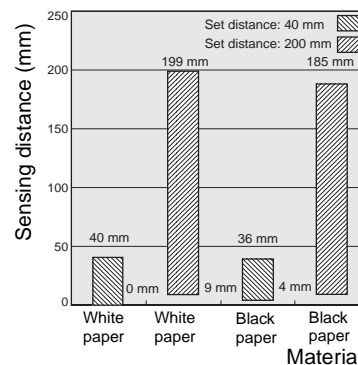

FGS Mode Set Distance vs. Sensing Range

White Paper

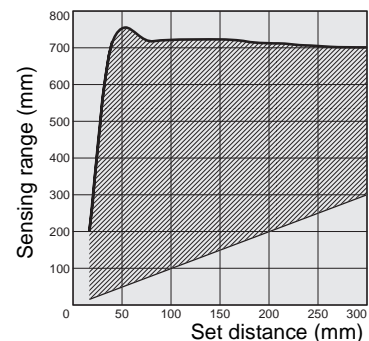

Black Paper

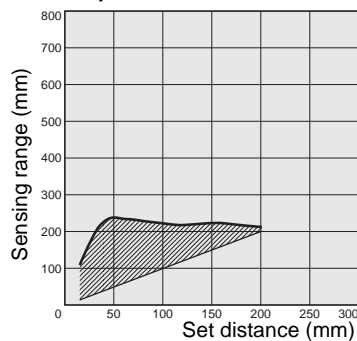

Hysteresis vs. Sensing Distance

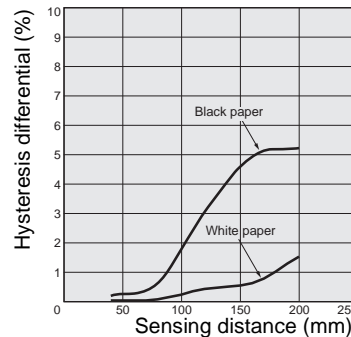

Sensing Distance vs. Material

At Set Distance of 40 mm

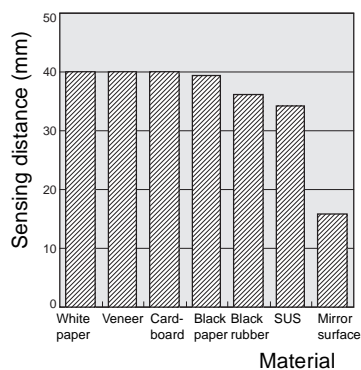

At Set Distance of 200 mm

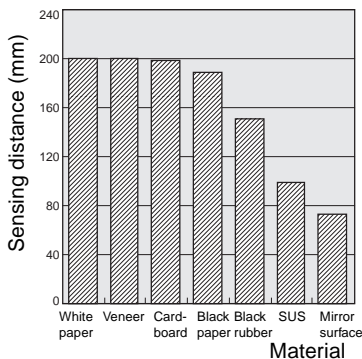

Operation

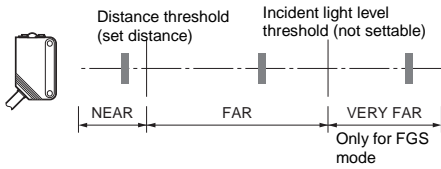

Note: The VERY FAR region is supported only for FGS. The incident light level threshold is fixed and cannot be set.

■ NPN Output

Model	Output transistor status	Timing chart	Mode selection switch	BGS/FGS selection method	Output circuit
E3Z-LS61 E3Z-LS66	Light ON		L side (L/ON)	BGS: Either leave the pink wire (2) open or connect it to the blue wire (3).	<p style="text-align: center;">Connector Pin Arrangement</p>
	Dark ON		D side (D/ON)		
	Light ON		L side (L/ON)	FGS: Connect the pink wire (2) to the brown wire (1).	
	Dark ON		D side (D/ON)		

■ PNP Output

Model	Output transistor status	Timing chart	Mode selection switch	BGS/FGS selection method	Output circuit
E3Z-LS81 E3Z-LS86	Light ON		L side (L/ON)	BGS: Either leave the pink wire (2) open or connect it to the blue wire (3).	<p>Connector Pin Arrangement</p>
	Dark ON		D side (D/ON)		
	Light ON		L side (L/ON)	FGS: Connect the pink wire (2) to the brown wire (1).	
	Dark ON		D side (D/ON)		

■ Connectors (Sensor I/O Connectors)

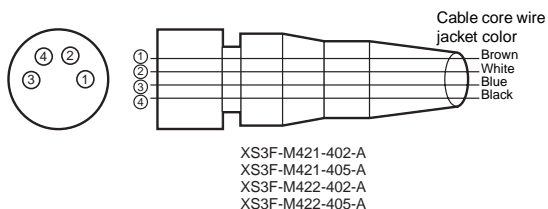

Class	Wire jacket color	Connector pin No.	Application
For DC	Brown	①	Power supply (+V)
	White	②	BGS/FGS selection
	Blue	③	Power supply (0 V)
	Black	④	Output

Nomenclature

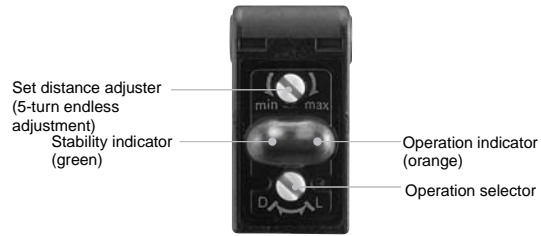

Dimensions

Pre-wired Sensors

E3Z-LS61
E3Z-LS81

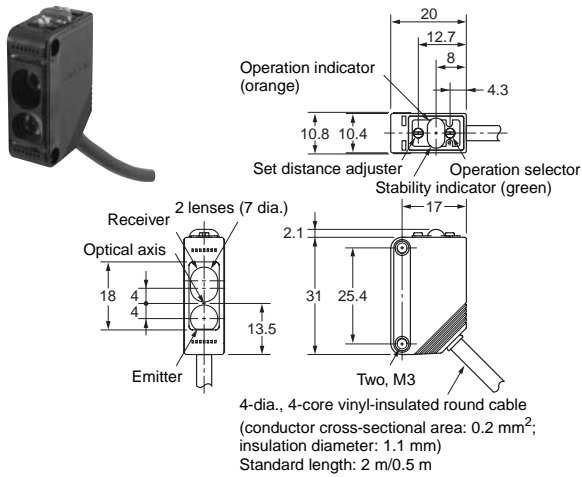

Sensors with M8 Connectors

E3Z-LS66
E3Z-LS86

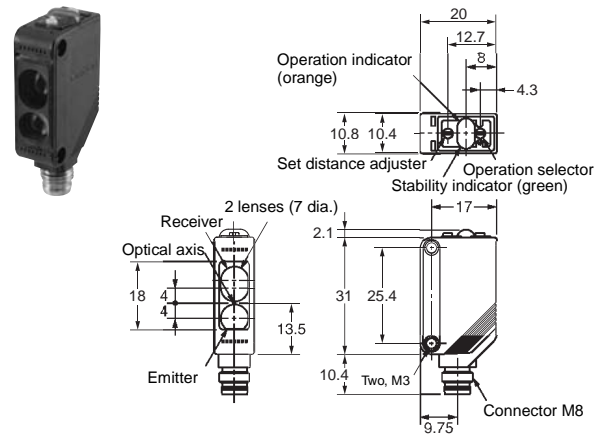

Precautions

⚠ Caution

Do not connect an AC power supply to the Sensor. If AC power (100 VAC or more) is supplied to the Sensor, it may explode or burn.

Be sure to abide by the following precautions for the safe operation of the Sensor.

Wiring

Power Supply Voltage and Output Load Power Supply Voltage

Make sure that the power supply to the Sensor is within the rated voltage range. If a voltage exceeding the rated voltage range is supplied to the Sensor, it may explode or burn.

Load Short-circuiting

Do not short-circuit the load, otherwise the Sensor may be damaged.

Connection without Load

Do not connect the power supply to the Sensor with no load connected, otherwise the internal elements may explode or burn.

Operating Environment

Do not use the Sensor in locations with explosive or flammable gas.

■ Correct Use

Design

Power Reset Time

The Sensor is ready to operate 100 ms after the Sensor is turned ON. If the load and Sensor are connected to independent power supplies respectively, be sure to turn ON the Sensor before supplying power to the load.

Wiring

Avoiding Malfunctions

If using the Photoelectric Sensor with an inverter or servomotor, always ground the FG (frame ground) and G (ground) terminals, otherwise the Sensor may malfunction.

Mounting

Mounting the Sensor

- If Sensors are mounted face-to-face, make sure that the optical axes are not in opposition to each other. Otherwise, mutual interference may result.
- Always install the Sensor carefully so that the aperture angle range of the Sensor will not cause it to be directly exposed to intensive light, such as sunlight, fluorescent light, or incandescent light.
- Do not strike the Photoelectric Sensor with a hammer or any other tool during the installation of the Sensor, or the Sensor will lose its water-resistive properties.
- Use M3 screws to mount the Sensor.
- When mounting the case, make sure that the tightening torque applied to each screw does not exceed 0.54 N·m.

M8 Connector

- Always turn OFF the power supply to the Sensor before connecting or disconnecting the metal connector.
- Hold the connector cover to connect or disconnect it.
- Secure the connector cover by hand. Do not use pliers, otherwise the connector may be damaged.

- If the connector is not connected securely, it may be disconnected by vibration or the proper degree of protection of the Sensor may not be maintained.

Mounting Directions

- Make sure that the sensing side of the Sensor is parallel with the surface of the sensing objects. Normally, do not incline the Sensor towards the sensing object.

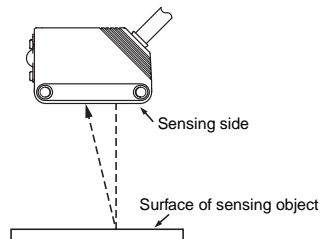

If the sensing object has a glossy surface, however, incline the Sensor by 5° to 10° as shown in the illustration, provided that the Sensor is not influenced by background objects.

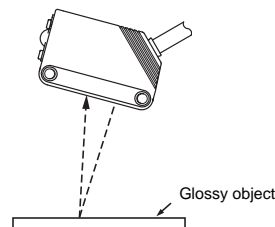

- If there is a mirror-like object below the Sensor, the Sensor may not operate stably. Therefore, incline the Sensor or separate the Sensor from the mirror-like object as shown below.

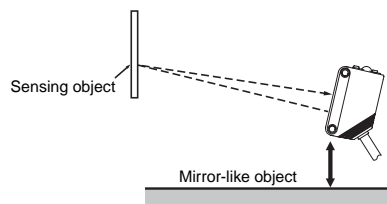

- Do not install the Sensor in the wrong direction. Refer to the following illustration.

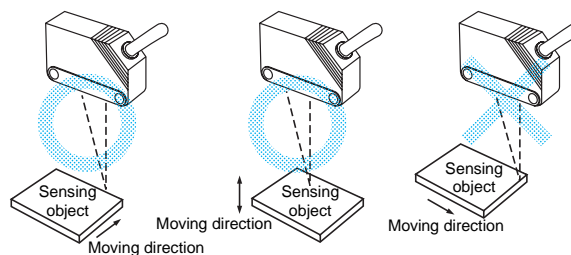

Install the Sensor as shown in the following illustration if each sensing object greatly differs in color or material.

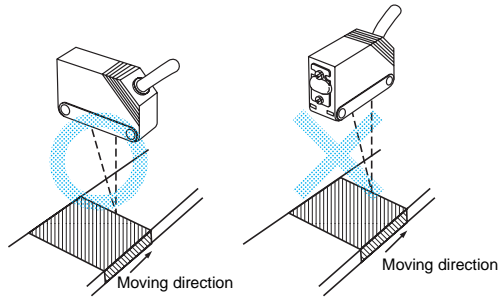

Adjustments

Indicator Operation

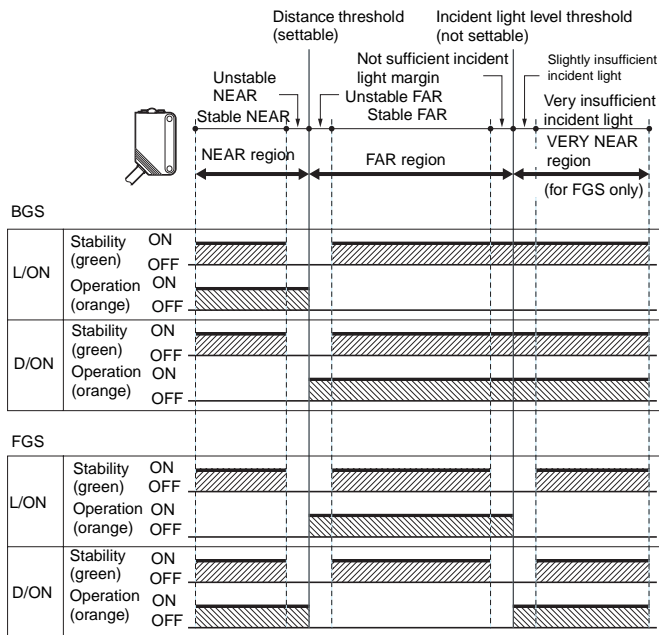

- Note:**
1. If the stability indicator is lit, the detection/no detection status is stable within the rated ambient operating temperature (-25 to 55°C).
 2. The VERY FAR region is supported only for FGS. The incident light threshold is fixed and cannot be set. The distance to the incident light threshold depends on the color and gloss of the sensing object's surface.





Inspection and Maintenance

Cleaning

Never use paint thinners or other organic solvents to clean the surface of the product.









E3Z Series Lineup

■ Complete E3Z Series Lineup: Photoelectric Sensors for the 21st Century





Sensing method item	Distance-settable (NEW)	Diffuse reflective		Narrow-beam diffuse reflective	Retroflective	Retroflective for PET bottles		Through-beam		Grooved type
Appearance										
Model	E3Z-LS	E3Z-D		E3Z-L	E3Z-R	E3Z-B		E3Z-T		E3Z-G
Sensing distance	20 mm to set distance (BGS mode) Set distance to 200 mm min. (FGS mode)	5 to 100 mm (wide vision)	1 m	90 ± 30 mm	4 m (100 mm) (See note 1.)	500 mm (80 mm) (See note 1.)	2 m (500 mm) (See note 1.)	15 m	10 m	25 mm
Light source (wavelength)	Red LED (680 nm)	Infrared LED (860 nm)		Red LED (670 nm)	Red LED (680 nm)		Infrared LED (860 nm)	Red LED (700 nm)	Infrared LED (940 nm)	
Power supply voltage	12 to 24 VDC ±10%, ripple (p-p) 10% max.									
Current consumption	30 mA max.							Emitter: 15 mA Receiver: 20 mA		25 mA max.
Control outputs	Load power supply voltage 26.4 VDC max., load current 100 mA max. (residual voltage 1 V max.) Open collector output (NPN or PNP depending on model) Light-ON/Dark-ON switch selectable									
Protective circuits	Reverse polarity protection, output short-circuit protection, mutual interference prevention (Mutual interference prevention is not provided on E3Z-T.)									
Response time	Operation or reset: 1 ms max.									
Sensitivity adjustment	5-turn endless adjuster	Single-turn adjuster								---
Ambient temperature	Operating: -25 to 55°C, Storage: -40 to 70°C (with no icing or condensation)									
Ambient humidity	Operating: 35% to 85%, Storage: 35% to 95% (with no condensation)									
Protective structure	IEC 60529 IP67									IEC 60529 IP64
Connection method	Pre-wired (standard length: 2 m/0.5 m) or M8 connector	Pre-wired (standard length: 2 m/0.5 m), M8 connector, or M12 connector relay (0.3 m)		Pre-wired (standard length: 2 m/0.5 m) or M8 connector	Pre-wired (standard length: 2 m/0.5 m), M8 connector, or M12 connector relay (0.3 m)	Pre-wired (standard length: 2 m/0.5 m) or M8 connector		Pre-wired (standard length: 2 m/0.5 m), M8 connector, or M12 connector relay (0.3 m, infrared type only)		Pre-wired (standard length: 2 m/0.5 m) or M8 connector relay (0.3 m)
Datasheet catalog number	E327-01	E308-01A		E311-01	E308-01A	E316-01		Infrared type: E319-01A Red type: E308-01A		E320-01

- Note:**
1. The sensing distance is for when an E39-R1S Reflector is used. The minimum distance between the Reflector and Sensor is given in parentheses.
 2. For details, refer to the main *Sensors* catalog (X042) and individual catalogs.

Mounting Brackets (Same for Entire E3Z Series)

Appearance	Model	Qty	Remarks	Appearance	Model	Qty	Remarks
	E39-L153	1	Mounting Bracket		E39-L150	1 set	Sensor Adjusters For easy mounting and adjustment with aluminum frames and rails, such as those on conveyors For horizontal adjustment
	E39-L104	1					
	E39-L43	1	Horizontal Mounting Bracket		E39-L151	1 set	
	E39-L142	1	Horizontal Protective Cover/ Mounting Bracket				
	E39-L44	1	Rear-connecting Mounting Bracket				
	E39-L98	1	Protective Cover/ Mounting Bracket		E39-L144	1 set	Compact Protective Cover/Mounting Bracket (for E3Z only)

Sensor I/O Connectors (Same for Entire E3Z Series)

Size	Cable specifications	Shape	Cable type		Model number
M8	Standard cable	Straight 	2 m	4-wire	XS3F-M421-402-A
			5 m		XS3F-M421-405-A
		L-shaped 	2 m		XS3F-M422-402-A
			5 m		XS3F-M422-405-A
M12 (for -M1J)		Straight 	2 m	3-wire	XS2F-D421-DC0-A
			5 m		XS2F-D421-GC0-A
		L-shaped 	2 m		XS2F-D422-DC0-A
			5 m		XS2F-D422-GC0-A



Ph: 03 5278 8222 Fax: 03 5278 9761
65 Douro Street, North Geelong VIC 3215
www.factorycontrols.com.au

ALL DIMENSIONS SHOWN ARE IN MILLIMETERS.

To convert millimeters into inches, multiply by 0.03937. To convert grams into ounces, multiply by 0.03527.

Cat. No. E327-E1-01A **In the interest of product improvement, specifications are subject to change without notice.**

OMRON Corporation

Industrial Automation Company

Industrial Sensors Division

Sensing Devices & Components Division H.Q.

3-2, Narutani, Nakayama-cho, Ayabe-shi,
Kyoto, 623-0105 Japan
Tel: (81)773-43-4078/Fax: (81)773-43-4030

Printed in Japan
0702-3M (0402) (H)