

Inductive Proximity Sensor TL-W/WM

Space Saving Flat Proximity Sensor

- Space-saving, low-profile rigid aluminum die-cast housing (TL-W5E/F).
- All models provided with an operation indicator.
- Mounting possible from either the front or rear of the housing.
- Protected to endure water and oil splashes (conforms to IEC IP67).
- DC 2-Wire Models (TL-W5MD1/-W5MD2) provide easy wiring.

<READ AND UNDERSTAND THIS CATALOG>

Please read and understand this catalog before purchasing the products. Please consult your OMRON representative if you have any questions or comments.



Ordering Information

DC 2-Wire

Shield	Sensing distance	Operation mode	
		NO	NC
Unshielded	5 mm	TL-W5MD1 (See note 1.)	TL-W5MD2 (See note 1.)

DC 3-Wire

Shield	Sensing distance	Output configuration/Operation mode			
		NPN		PNP	
		NO	NC	NO	NC
Shielded	5 mm	TL-W5E1	TL-W5E2	TL-W5F1	TL-W5F2
Unshielded	1.5 mm	TL-W1R5MC1 (See note 1, 2.)	---	TL-W1R5MB1	---
	3 mm	TL-W3MC1 (See note 1, 2.)	TL-W3MC2	TL-W3MB1	TL-W3MB2
	5 mm	TL-W5MC1 (See note 1, 2.)	TL-W5MC2	TL-W5MB1	---
	20 mm	TL-W20ME1 (See note 1.)	TL-W20ME2 (See note 1.)	---	---

Note 1. Models with different frequencies to prevent mutual interference are available. The model numbers are TL-W□□□□5 (e.g., TL-W5MD15).

2. Models with flexible cable are available. The model numbers are TL-W□□□□-R (e.g., TL-W1R5MC1-R).

Application Examples

Position of Workpiece

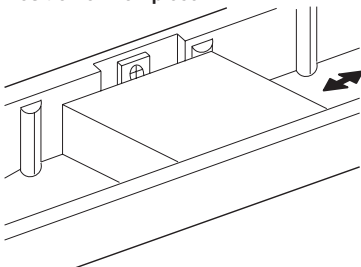

Specifications

■ Ratings/Characteristics

DC 2-Wire

Item		TL-W5MD
Sensing distance		5 mm \pm 10%
Set distance		0 to 4 mm
Differential travel		10% max. of sensing distance
Sensing object		Ferrous metal (The sensing distance decreases with non-ferrous metal. Refer to <i>Engineering Data</i> .)
Standard sensing object		Iron, 18 \times 18 \times 1 mm
Response speed (See note.)		500 Hz
Power supply voltage (operating voltage range)		12 to 24 VDC, ripple (p-p): 10% max. (10 to 30 VDC)
Current consumption (leakage current)		0.8 mA max.
Control output	Load current	3 to 100 mA
	Residual voltage	3.3 V max. (under load current of 100 mA with cable length of 2 m)
Indicator		D1 Models: Operation indicator (red LED), operation set indicator (green LED) D2 Models: Operation indicator (red LED)
Operation mode (with sensing object approaching)		D1 Models: NO D2 Models: NC For details, refer to <i>Timing Charts</i> .
Protection circuits		Short-circuit protection, surge suppressor
Ambient temperature		Operating/Storage: -25°C to 70°C (with no icing or condensation)
Ambient humidity		Operating/Storage: 35% to 95% (with no condensation)
Temperature influence		\pm 10% max. of sensing distance at 23°C in the temperature range of -25°C to 70°C
Voltage influence		\pm 2.5% max. of sensing distance in the rated voltage range \pm 15%
Insulation resistance		50 M Ω min. (at 500 VDC) between current-carrying parts and case
Dielectric strength		1,000 VAC for 1 min between current-carrying parts and case
Vibration resistance		10 to 55 Hz, 1.5-mm double amplitude for 2 hours each in X, Y, and Z directions
Shock resistance		500 m/s ² , 3 times each in X, Y, and Z directions
Degree of protection		IEC IP67 [JEM IP67G (water-tight, oil-tight)]
Weight (packed state)		Approx. 45 g
Material	Case	Heat-resistant ABS resin
	Sensing surface	
Accessories		Instruction manual

Note: The response speed is an average value. Measurement conditions are as follows: Standard sensing object, a distance of twice the standard sensing object, and a set distance of half the sensing distance.

DC 3-Wire

Item		TL-W1R5M	TL-W3M	TL-W5M	TL-W5	TL-W20M
Sensing distance		1.5 mm ±10%	3 mm ±10%	5 mm ±10%		20 mm ±10%
Set distance		0 to 1.2 mm	0 to 2.4 mm	0 to 4 mm		0 to 16 mm
Differential travel		10% max. of sensing distance				1% to 15% of sensing distance
Sensing object		Ferrous metal (The sensing distance decreases with non-ferrous metal. Refer to <i>Engineering Data</i> .)				
Standard sensing object		Iron, 8 × 8 × 1 mm	Iron, 12 × 12 × 1 mm	Iron, 18 × 18 × 1 mm		Iron, 50 × 50 × 1 mm
Response speed (See note.)		1 kHz min.	600 Hz min.	500 Hz min.	300 Hz min.	40 Hz min.
Power supply voltage (operating voltage range)		12 to 24 VDC (10 to 30 VDC), ripple (p-p): 10% max.			12 to 24 VDC (10 to 30 VDC), ripple (p-p): 20% max.	12 to 24 VDC (10 to 30 VDC), ripple (p-p): 10% max.
Current consumption (leakage current)		15 mA max. at 24 VDC (no-load)		10 mA max.	15 mA max. at 24 VDC (no-load)	8 mA at 12 VDC, 15 mA at 24 VDC
Control output	Load current	NPN or PNP open collector, 100 mA max. (30 VDC max.)		NPN or PNP open collector, 50 mA max. at 12 VDC (30 VDC max.), 100 mA max. at 24 VDC (30 VDC max.)	200 mA max.	100 mA max. at 12 VDC, 200 mA max. at 24 VDC
	Residual voltage	1.0 V max. (under load current of 100 mA with cable length of 2 m)		1.0 V max. (under load current of 50 mA with cable length of 2 m)	2.0 V max. (under load current of 200 mA with cable length of 2 m)	1.0 V max. (under load current of 200 mA with cable length of 2 m)
Indicator		Detection indicator (red LED)				
Operation mode (with sensing object approaching)		NO	C1/B1 Models: NO C2/B2 Models: NC		E1/F1 Models: NO E2/F2 Models: NC	
		For details, refer to <i>Timing Charts</i> .				
Protection circuits		Reverse polarity protection, surge suppressor				---
Ambient temperature		Operating/Storage: -25°C to 70°C (with no icing or condensation)				
Ambient humidity		Operating/Storage: 35% to 95% (with no condensation)				
Temperature influence		±10% max. of sensing distance at 23°C in the temperature range of -25°C to 70°C				
Voltage influence		±2.5% max. of sensing distance in the rated voltage range ±10%		±2.5% max. of sensing distance in the rated voltage range ±20%	±2.5% max. of sensing distance in the rated voltage range ±10%	
Insulation resistance		50 MΩ min. (at 500 VDC) between current-carrying parts and case				
Dielectric strength		1,000 VAC, 50/60 Hz for 1 min between current-carrying parts and case				
Vibration resistance		10 to 55 Hz, 1.5-mm double amplitude for 2 hours each in X, Y, and Z directions				
Shock resistance		500 m/s ² , 3 times each in X, Y, and Z directions				500 m/s ² , 10 times each in X, Y, and Z directions
Degree of protection		IEC IP67 [JEM IP67G (water-tight, oil-tight)]				
Weight (packed state)		Approx. 30 g		Approx. 45 g	Approx. 70 g	Approx. 180 g
Material	Case	Heat-resistant ABS resin			ADC (Al die-cast)	Heat-resistant ABS resin
	Sensing surface	Heat-resistant ABS resin				
Accessories		Mounting Bracket, instruction manual		Instruction manual		

Engineering Data

Sensing Area (Typical)

TL-W1R5M

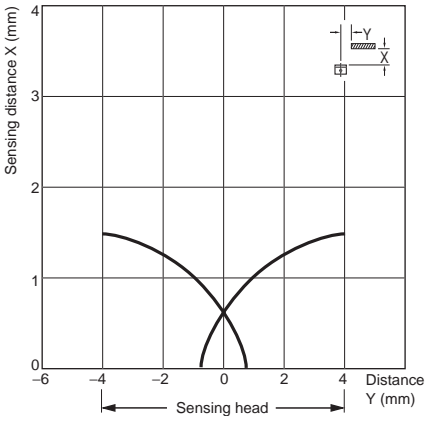

TL-W3M

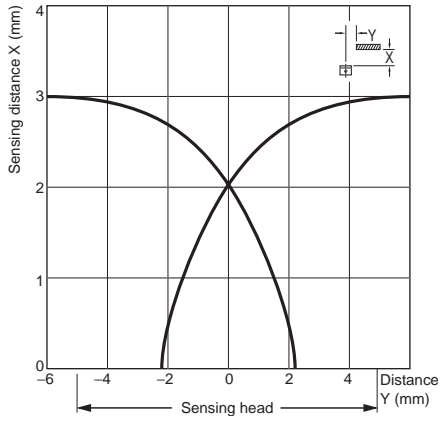

TL-W5M

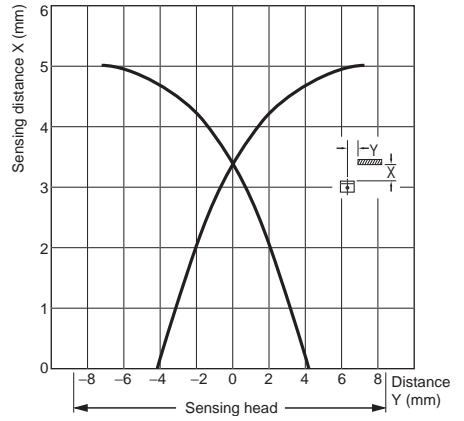

TL-W5

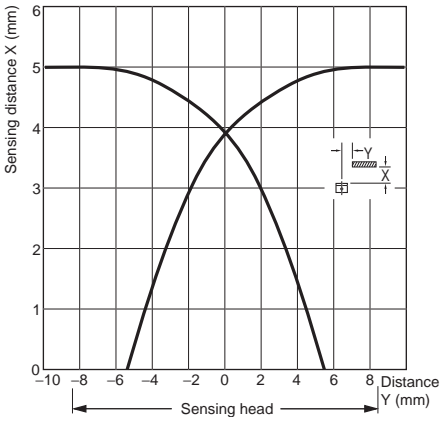

TL-W20M

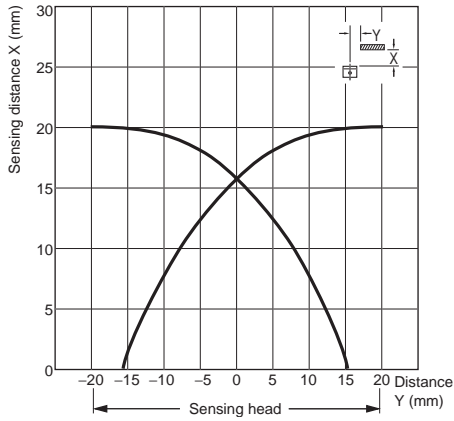

Influence of Sensing Object Size and Material

TL-W1R5M

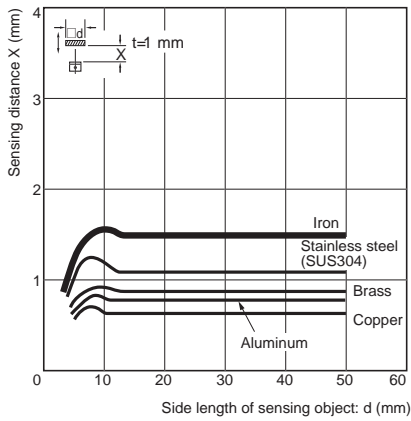

TL-W3M

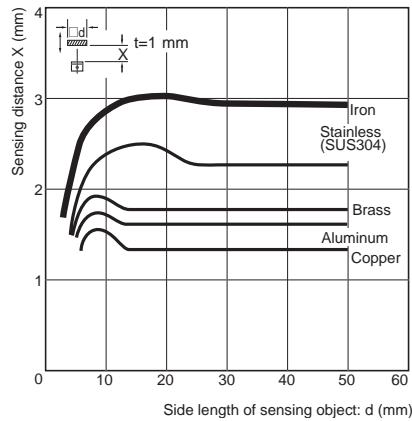

TL-W5M

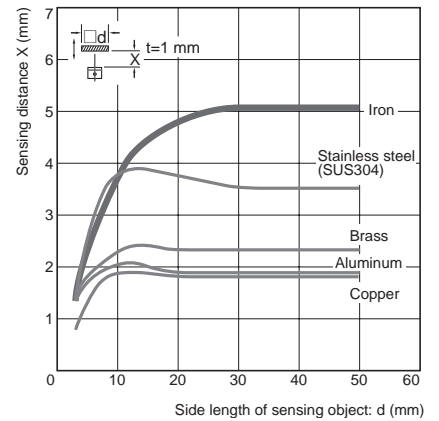

TL-W5

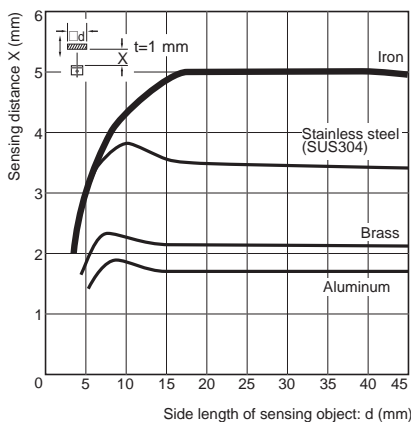

TL-W20M

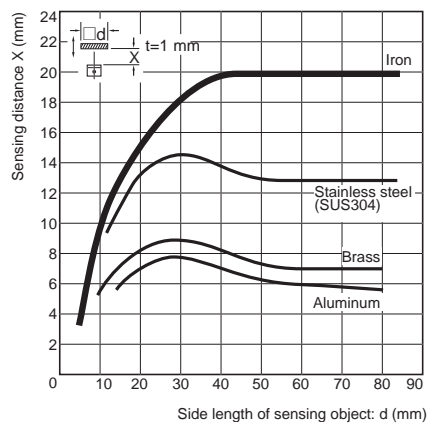

Operation

■ Output Circuits

DC 2-Wire

TL-W5MD□

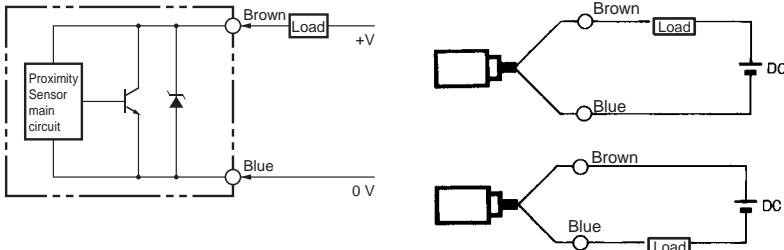

Note: The load can be connected as shown in the above diagram.

DC 3-Wire

TL-W1R5MC1
TL-W3MC□
TL-W5MC□

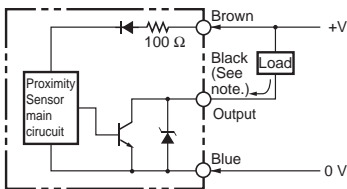

Note: Maximum load current: 100 mA

TL-W5E□
TL-W20ME□

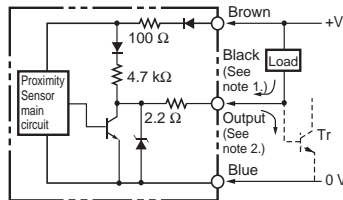

Note 1. Maximum load current: 200 mA
Note 2. When connecting to a Tr circuit.

TL-W5F□

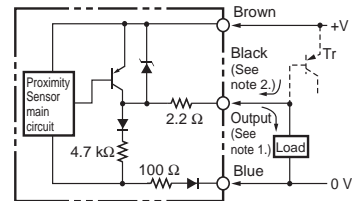

TL-W1R5MB1
TL-W3MB□
TL-W5MB1

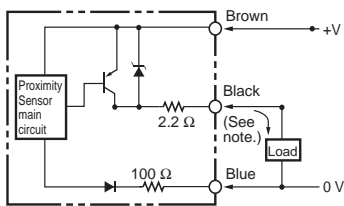

Note: Maximum load current: 100 mA

Timing Charts

DC 2-Wire

TL-W5MD1
NO Model

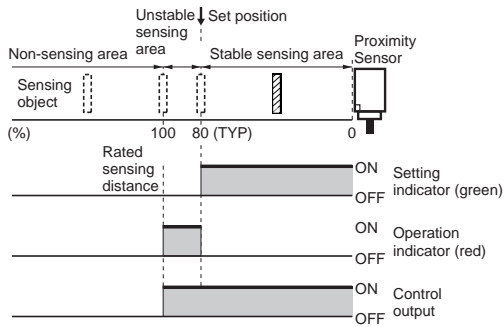

TL-W5MD2
NC Model

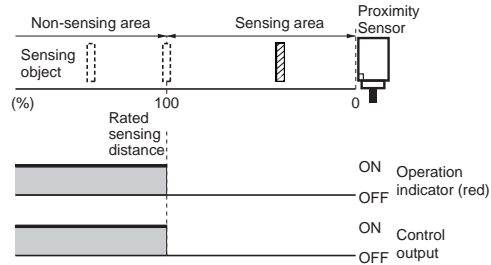

DC 3-Wire

TL-W1R5M□1
TL-W3M□
TL-W5M□

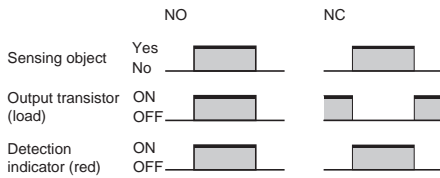

TL-W5F□

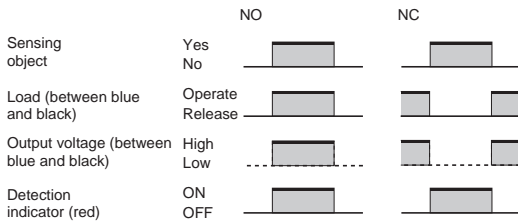

TL-W5E□
TL-W20ME□

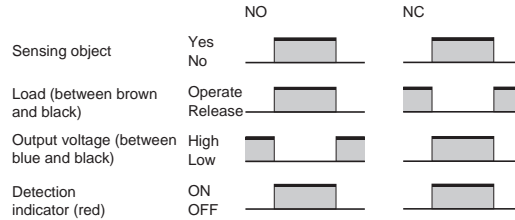

Precautions

⚠ WARNING

This product is not designed or rated for ensuring safety of persons. Do not use it for such purposes.



■ Precautions for Safe Use

Power Supply

Do not impose an excessive voltage on the TL-W, otherwise it may be damaged. Do not impose AC current (100 to 240 VAC) on any DC Model, otherwise it may be damaged.

■ Precautions for Correct Use

Influence of Surrounding Metals

Provide a minimum distance as shown in the table below between the TL-W and the surrounding metals to prevent the TL-W from being induced by the metals and malfunctioning or being affected by the heat radiated by the metals.

Model	l	m	n
TL-W1R5M□1	2 mm	0 mm	8 mm
TL-W3M	3 mm	0 mm	12 mm
TL-W5MD	5 mm	0 mm	20 mm
TL-W5MC/MB	5 mm	0 mm	20 mm
TL-W20ME	25 mm	16 mm	100 mm
TL-W5E/F	0 mm	0 mm	20 mm

Metal on a Single Side
(not exceeding the height of the Sensor head)

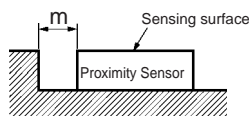

Metals on Both Sides and in front of the Sensor

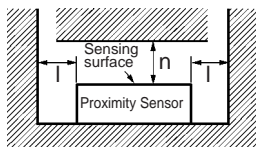

● Adjustment

Turning ON the Power

An error pulse will occur (approximately 1 ms) if adjustments are made when turning ON the power or making AND connections.

Load Short-circuit

Do not short-circuit the load, or the TL-W may be damaged.

The TL-W's short-circuit protection function will be valid if the polarity of the supply voltage imposed is correct and within the rated voltage range.

Wiring

Be sure to wire the TL-W and load correctly, otherwise it may be damaged.

Connection with No Load

Be sure to insert loads when wiring. Make sure to connect a proper load to the TL-W in operation, otherwise it may damage internal elements.

Mutual Interference

Be sure to space the two Sensors at a distance greater than that shown in the table to prevent mutual interference.

Model	A	B
TL-W1R5M□1	75 (50) mm	25 (8) mm
TL-W3M	90 (60) mm	30 (10) mm
TL-W5MD	120 (80) mm	60 (30) mm
TL-W5MC/MB	120 (80) mm	60 (30) mm
TL-W20ME	200 (100) mm	200 (100) mm
TL-W5E/F	50 mm	35 mm

Note: The above values in parentheses are applicable when using two Sensors with different frequencies.

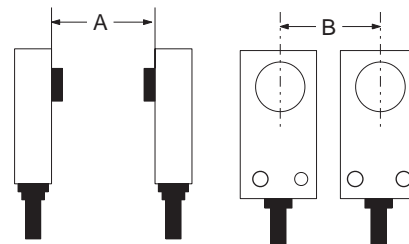

Mounting

Use M3 flat-head screws to mount the TL-W1R5M□1 and TL-W3M□1.

The resin cover should be tightened to 0.98 N·m maximum. The TL-W20ME□, however, is 1.5 N·m maximum.

Dimensions

Note: All units are in millimeters unless otherwise indicated.

TL-W1R5M□1

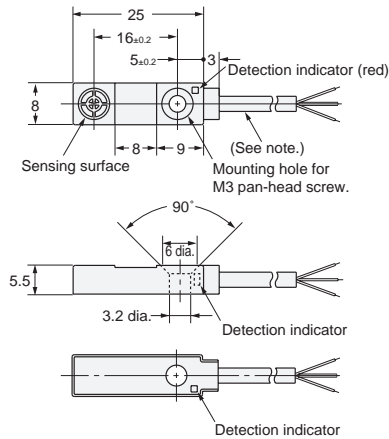
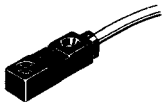

Note: 2.9-dia. vinyl-insulated round cable with 3 conductors (Conductor cross section: 0.14 mm², Insulator diameter: 0.9 mm), Standard length: 2 m

Mounting Bracket (Attachment)

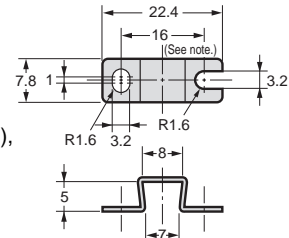

Note: Mounting dimensions: 17±0.2
Material: Stainless steel (SUS304)

TL-W3M□□

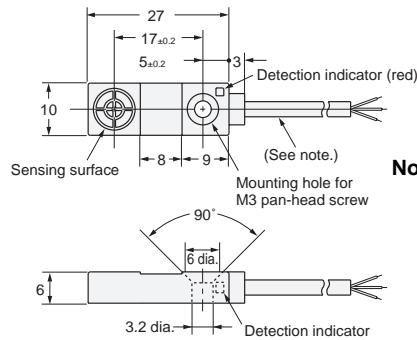
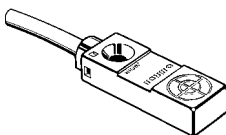

Note: 2.9-dia. vinyl-insulated round cable with 3 conductors (Conductor cross section: 0.14 mm², Insulator diameter: 0.9 mm), Standard length: 2 m

Mounting Bracket (Attachment)

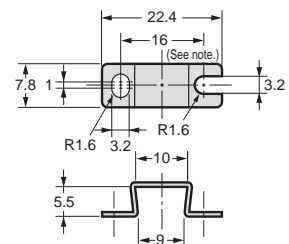

Note: Mounting dimensions: 17±0.2
Material: Stainless steel (SUS304)

TL-W5M□□ TL-W5MD□

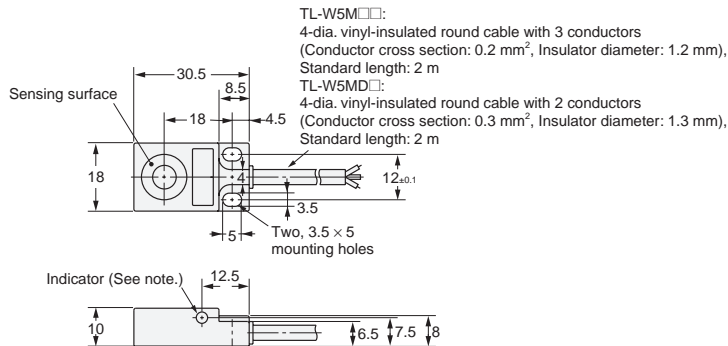
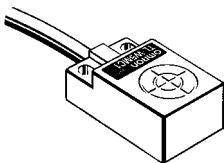

TL-W5M□□:
4-dia. vinyl-insulated round cable with 3 conductors (Conductor cross section: 0.2 mm², Insulator diameter: 1.2 mm), Standard length: 2 m
TL-W5MD□:
4-dia. vinyl-insulated round cable with 2 conductors (Conductor cross section: 0.3 mm², Insulator diameter: 1.3 mm), Standard length: 2 m

Note: C, B Models: Detection indicator (red)
D Models: Operation indicator (red)
Setting indicator (green)

TL-W5E□

TL-W5F□

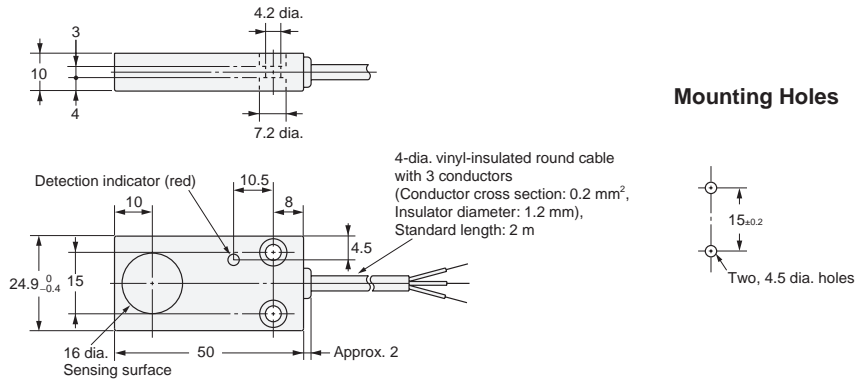
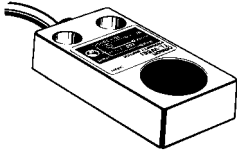

TL-W20ME□

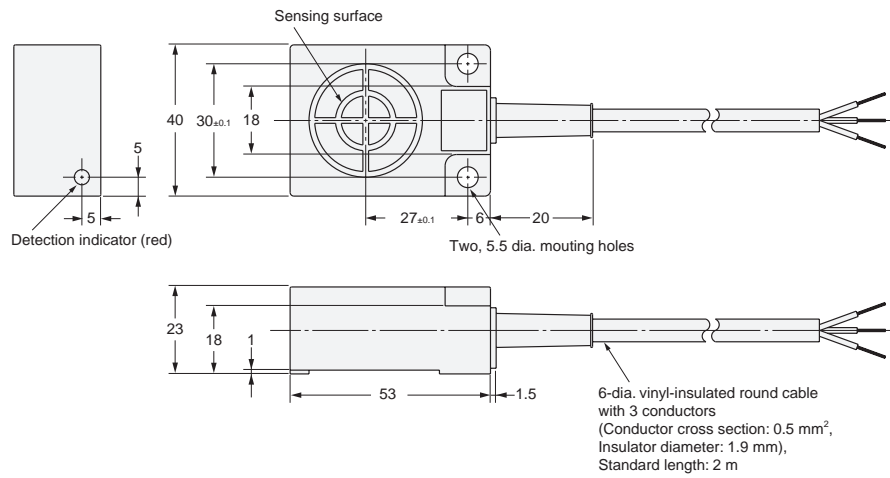
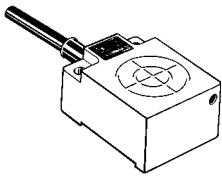

Warranties and Limitations of Liability

■ WARRANTY

OMRON's exclusive warranty is that the products are free from defects in materials and workmanship for a period of one year (or other period if specified) from date of sale by OMRON.

OMRON MAKES NO WARRANTY OR REPRESENTATION, EXPRESS OR IMPLIED, REGARDING NON-INFRINGEMENT, MERCHANTABILITY, OR FITNESS FOR PARTICULAR PURPOSE OF THE PRODUCTS. ANY BUYER OR USER ACKNOWLEDGES THAT THE BUYER OR USER ALONE HAS DETERMINED THAT THE PRODUCTS WILL SUITABLY MEET THE REQUIREMENTS OF THEIR INTENDED USE. OMRON DISCLAIMS ALL OTHER WARRANTIES, EXPRESS OR IMPLIED.

■ LIMITATIONS OF LIABILITY

OMRON SHALL NOT BE RESPONSIBLE FOR SPECIAL, INDIRECT, OR CONSEQUENTIAL DAMAGES, LOSS OF PROFITS OR COMMERCIAL LOSS IN ANY WAY CONNECTED WITH THE PRODUCTS, WHETHER SUCH CLAIM IS BASED ON CONTRACT, WARRANTY, NEGLIGENCE, OR STRICT LIABILITY.

In no event shall responsibility of OMRON for any act exceed the individual price of the product on which liability is asserted.

IN NO EVENT SHALL OMRON BE RESPONSIBLE FOR WARRANTY, REPAIR, OR OTHER CLAIMS REGARDING THE PRODUCTS UNLESS OMRON'S ANALYSIS CONFIRMS THAT THE PRODUCTS WERE PROPERLY HANDLED, STORED, INSTALLED, AND MAINTAINED AND NOT SUBJECT TO CONTAMINATION, ABUSE, MISUSE, OR INAPPROPRIATE MODIFICATION OR REPAIR.

Application Considerations

■ SUITABILITY FOR USE

THE PRODUCTS CONTAINED IN THIS CATALOG ARE NOT SAFETY RATED. THEY ARE NOT DESIGNED OR RATED FOR ENSURING SAFETY OF PERSONS, AND SHOULD NOT BE RELIED UPON AS A SAFETY COMPONENT OR PROTECTIVE DEVICE FOR SUCH PURPOSES. Please refer to separate catalogs for OMRON's safety rated products.

OMRON shall not be responsible for conformity with any standards, codes, or regulations that apply to the combination of products in the customer's application or use of the product.

Take all necessary steps to determine the suitability of the product for the systems, machines, and equipment with which it will be used.

Know and observe all prohibitions of use applicable to this product.

NEVER USE THE PRODUCT FOR AN APPLICATION INVOLVING SERIOUS RISK TO LIFE OR PROPERTY WITHOUT ENSURING THAT THE SYSTEM AS A WHOLE HAS BEEN DESIGNED TO ADDRESS THE RISKS, AND THAT THE OMRON PRODUCT IS PROPERLY RATED AND INSTALLED FOR THE INTENDED USE WITHIN THE OVERALL EQUIPMENT OR SYSTEM.

Disclaimers

■ CHANGE IN SPECIFICATIONS

Product specifications and accessories may be changed at any time based on improvements and other reasons. Consult with your OMRON representative at any time to confirm actual specifications of purchased product.

■ DIMENSIONS AND WEIGHTS

Dimensions and weights are nominal and are not to be used for manufacturing purposes, even when tolerances are shown.

ALL DIMENSIONS SHOWN ARE IN MILLIMETERS.

To convert millimeters into inches, multiply by 0.03937. To convert grams into ounces, multiply by 0.03527.

Cat. No. E221-E1-03

In the interest of product improvement, specifications are subject to change without notice.

OMRON Corporation

Industrial Automation Company

Industrial Sensors Division

Sensing Devices and Components Division H.Q.

Shiokoji Horikawa, Shimogyo-ku,

Kyoto, 600-8530 Japan

Tel: (81)75-344-7022/Fax: (81)75-344-7107



Ph: 03 5278 8222 Fax: 03 5278 9761

65 Douro Street, North Geelong VIC 3215

www.factorycontrols.com.au