

VLT® HVAC Drive For HVAC it has to be VLT®

1.5 mio

VLT® HVAC Drives

reliably perform tasks in HVAC systems. Rely on proven VLT® technology – now with PM motor control for efficient control of EC and IEC standard motors.

56%

Energy use reduction

in Mumbai's VSNL building. 'Only by using Variable Frequency Drives in the HVAC system could we achieve this target' – General Manager VSNL, India.



VLT® HVAC Drive provides **the lowest life-time cost**

The VLT® HVAC Drive is the safe choice for fan, pump or compressor applications. It provides a high flexibility with regard to the site of installation, range of available bus systems, broadest HVAC control intelligence and functionality, and respects the building environment by offering the best EMC and harmonics behaviour on the market.

The HVAC Drive offers the highest efficiency solution with both asynchronous motors and perma-

nent magnet motors. It can log and record its own energy load profile for both the estimation and validation of actual energy savings.

The VLT® HVAC Drive is a singular engineering platform for all your variable speed needs, designed to minimize the total applied system cost and lifecycle cost.

In everything we do, Danfoss is a clean tech company.

The VLT® HVAC Drive includes:

- > 98% basic energy efficiency
- Automatic Energy Optimisation
- User-friendly operation
- Programming in 27 languages
- VLT® quality up to 1.4 MW

Save money

The modular design enables the user greater flexibility to select from a range of functional performance requirements to secure the best cost advantage for their application needs.

Easy commissioning

- Application menus
- Quick menu
- Motor Rotation Check
- PID-auto tuning



High ambient temperature

The robust VLT® HVAC Drive is designed to work at maximum output in an ambient temperature up to 50° C. At higher temperatures, the drive will continue operation with lower performance.

Automatic derating enables reduced operation for a period of time at higher ambient temperatures to maintain operation of the HVAC system.

Maintenance free

Due to a series of self-protecting and monitoring features and a highly durable mechanical design, the VLT® HVAC Drive is maintenance free, except for general cleaning. No replacement of internal fans or capacitors is required.

Save space

Due to its compact dimensions, the VLT® HVAC Drive is easily mounted inside an HVAC unit or panel, reducing overall enclosure costs and freeing up panel backspace for other devices.

Save energy

The energy consumption from HVAC applications such as fans and pumps rises with the cube of the flow. That's the reason why VLT® control of such applications typically saves 48% energy compared to on-off operation.

Fire Override Mode

Fire Override Mode helps keep fire escape routes free of smoke, overrides the drive's self-protecting features and keeps the driven equipment running as long as possible in the event of fire.

Activating Fire Override Mode will ensure the VLT® HVAC Drive ignores "soft" faults and alarms to continue operation during essential services such as a "fire" command.

Save cabinet

We offer a standard & integrated IP55/Type 12 protection class equal to that of the motor.

This eliminates the cost of a separate enclosure and saves on the additional installation costs associated with installation in a remote location.

IP 66/Type 4x Indoor for harsh environments

The IP 66/Type 4x enclosure option for harsh environments can eliminate the cost of a separate enclosure and reduce the installation costs associated with remote installations.

EMC & network protection

Fully integrated EMC filters eliminate the cost of installing external EMC filters and secure the highest integrity & fully tested EMC performance.

All versions of VLT® HVAC Drive comply as standard with EMC limits according to the EN 61800-3 norm (page 13).

All A1 and B filter options are available as factory built-in options.

The standard integrated DC coils also ensure low harmonic load on the network within EN 61000-3-12 and increase the lifespan of the DC link capacitors. They also ensure that the drive can operate motors to their full rated performance.

For further protection against harmonic disturbances of the supply grid, Danfoss provides passive solutions such as 12/18 pulse solutions and Advanced Harmonic Filters (AHF).

Active solutions

Danfoss also provides active solutions such as Low Harmonic Drives, combining standard drives with an active filter and stand-alone VLT® Advanced Active Filters (AAF).

Proven reliability

The first VLT® HVAC Drive – the VLT® 100 from 1983 – has proven the reliability of VLT® drives. Original VLT® HVAC Drives installed in 1983 are still functioning reliably over 20 years later.

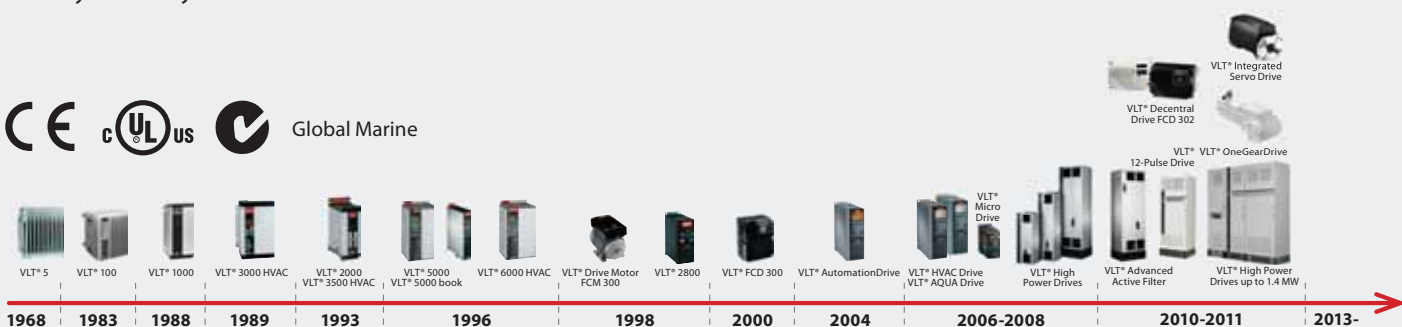

VLT® HVAC Drives make your building green

Expect optimisation

Danfoss' long experience in applying drives in HVAC systems has enhanced its ability to offer a "Best in Class" technical expertise in integrating the drive into the overall system design. This extracts the maximum value from your initial investment and optimizes the operational savings performance.

The 21st Century focus on energy efficiency is not new with regard to energy saving, but the emphasis on the consequences of wasted energy and the over-use of fossil fuels to produce energy, is at the top of the agenda.

Climate Change is seen as a cost to the human race more than simply a financial cost.

Save energy and CO₂ emission

VLT® frequency converters save more than 20 million MWh of energy

globally each year. This is equivalent to the annual electricity consumption of 5 million homes.

This energy saving reduces annual CO₂ emissions of over 12 million tons!

Makes the building perform

Today the prime focus is on the overall performance of buildings including design, construction, efficiency, sustainability and the environmental impact of these buildings in the future.

Energy efficient products form part of this overall plan. In most countries around the world this is now realized in the evaluation of high performance buildings under the banner LEED.

We offer you a wealth of knowledge

The various applications incorporated within high performance buildings are well understood by Danfoss and as a global market leader, we have built a wealth of knowledge and

understanding of the applications and developed products and technology to ensure we meet and determine future trends in this industry. Our 40 years of experience in this business have made the VLT® HVAC Drive the industry benchmark.

Premier drive in the market

The efficiency of the VLT® HVAC Drive and its built-in features make the VLT® HVAC Drive the premier drive in the market today.

Danfoss' application and industry knowledge will ensure that the investment made in VLT® drives provides a qualified return. Financial incentives are just as important as moral incentives to encourage people to choose energy efficient solutions.



Reliable and cost effective

Correct drive selection is critical to reliability. Products that introduce unacceptable levels of RFI or harmonics into a building can prove highly problematic and costly in addition to breaking legislative regulations.

Danfoss' many years of experience in the application of VLT® drives and in the HVAC industry in particular, has resulted in a global team focused on delivering the best drives solution, ensuring total security of your investment.

Minimum impact on the environment

Having chosen to fit a VLT® drive as part of the building control architecture, the lifetime sustainability of this product is an important aspect.

New regulations are forcing manufacturers to look at how they manufacture, what they manufacture and with what materials.

Are products harmful to make? Are they harmful to dispose of at their

end-of-life? Danfoss complies with RoHS, WEEE Directives, ISO14001; all standards and directives created to ensure the minimum impact on the environment.

Energy monitoring

The VLT® HVAC Drive provides a complete range of energy consumption information. Choose to divide absolute energy consumption into hours, days or weeks or to monitor a load profile for the application.

Energy documentation

VLT® Energy Box software is the most modern and advanced energy calculation tool available.

It allows energy consumption calculations and comparisons of HVAC fans, pumps and cooling tower applications driven by Danfoss drives and alternative methods of flow control.

The program compares the total operational costs of various traditional systems to operation of the same systems with a VLT® HVAC Drive.

With this program it is easy to evaluate the savings by comparing a VLT® HVAC Drive over other types of capacity control systems in both new installations as well as retrofit situations.

Complete financial analysis

VLT® Energy Box provides a complete financial analysis including:

- Initial cost for the drive system and the alternative system
- Installation and hardware costs
- Annual maintenance costs and any utility company incentives for energy conservation products
- Payback time and accumulated savings

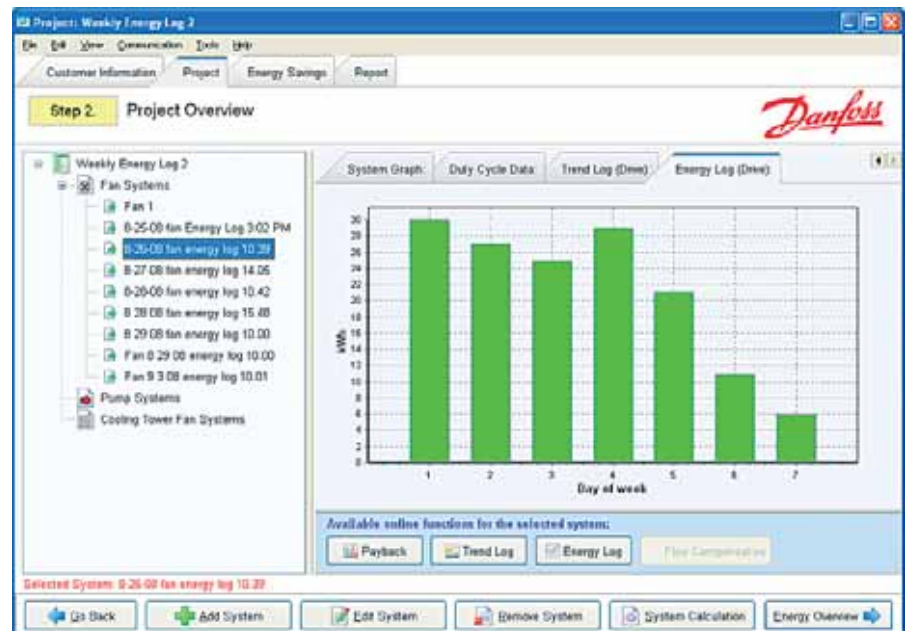

- Upload of actual energy consumption (kWh) and duty cycle from the VLT® HVAC Drive

VLT® Energy Box makes it possible to capture actual energy data from the drives and monitor energy consumption and overall system efficiency.

Energy audit

The VLT® HVAC Drive coupled with Energy Box software enables the package to be used as the Energy

Audit equipment for both the estimation and validation of savings.

VLT® HVAC Drive can be interrogated remotely for full energy data, making it easy to monitor your energy savings and return on investment. Monitoring via fieldbus often makes energy meters omissible.



Danfoss VLT® HVAC Drive provides lowest cost of ownership

Total Cost of Ownership is an organization's total cost of acquiring, operating and maintaining a system through a given lifecycle.

Total Cost of Ownership includes initial acquisition cost and operating cost. Through its technology and experience, Danfoss can transform this into the "Benefit of Ownership".

We understand the needs of our customers, operating their facilities in a competitive environment which requires total system cost effective-

ness and highest efficiency in daily operations with environmental sustainability.

Danfoss dedicated HVAC organization at your side

Customer assurance stems from Danfoss' dedicated and highly experienced HVAC support team.

It has the depth of understanding in HVAC applications that ensures the maximum benefit is extracted from the customers' investment in VLT® drive systems.

Reducing acquisition costs

- Fully integrated EMC & Harmonic compliant solution
- IP 21/55/66; Type 1/12/4x
- Extensive HVAC functions to reduce other system components
- Extendable I/O to reduce total BMS costs
- Ease of installation and set-up

Reducing operating costs

- Minimum 98% efficiency
- Energy metering
- Automatic Energy Optimisation
- Design lifetime of 10 years
- Danfoss legacy and history in HVAC applications
- IP enclosures and optional conformal coating to provide robust & reliable performance in the harshest of environments
- 50° C ambient temperature without derating
- Auto derate functions above 50°
- Broadest range of drive and motor protection
- Maintenance free drive
- System diagnostics

Enhanced advanced monitoring

Enhanced advanced application monitoring functionality for fans allows you to also keep track of the status of pumps and compressors. This can mean increased lifetime, reduced maintenance costs, and less downtime.

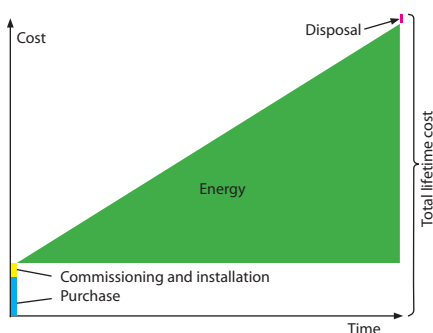

Supporting software tool

Software tools are available to help design a system with minimal harmonics and best energy efficiency.

Protection mode

As soon as the system detects a critical status, (e.g. over-current or over-voltage) the frequency of the VLT® HVAC Drive will automatically be reduced and the modulation process adjusted.

Due to its ability to limit its switching operations, the VLT® HVAC Drive is extremely reliable and robust. The protection mode will – if allowable – end after 10 seconds and the frequency will be restored under control.

Minimum 98% efficiency

The VLT® HVAC Drive sets new standards with a minimum 98% efficiency at full load. This reduces initial costs and operating costs due to the smaller heat load/air conditioning requirement in the switchroom/plantroom, thereby maximizing energy efficiency. Every kW of losses requires another ~0.5 kW of energy to remove the heat.

Installed in an air conditioned switchroom, lower losses can easily result in operating cost savings >5% – 10% of the cost of the drive every year (based on a typical load profile, with the drive operating 24/7). Also energy consumption and CO₂ emissions are reduced.

High Ambient Temperatures

VLT® HVAC Drive is designed to operate in ambient temperatures up to 50° C with an autoderate capability for higher temperatures in order to maintain reduced operation in extreme climate conditions.

In most cases, the VLT® HVAC Drive will handle abnormal situations without needing attention.

VLT® HVAC Drive will manage the loss of a mains phase or a high mains imbalance by autoderating speed and load to maintain a period of reduced operation, enabling technicians to respond to the situation.

NEW!

The Danfoss EC+ concept...

... enables the use of PM motors in IEC-standard sizes with Danfoss VLT® frequency converters.

After entering the relevant motor data, you benefit from the high efficiency of EC technology in all applications.

The necessary control algorithm has been embedded in dedicated VLT® series drives.

Benefits of the EC + concept:

- Free choice of motor technology: PM or asynchronous with the same frequency converter
- Operation and installation of the VLT® drive remain the same
- Vendor-independent selection of all components
- Best system efficiency by combining efficiency-optimized components
- Retrofit of existing plant
- Supports a broad range of standard and PM motors

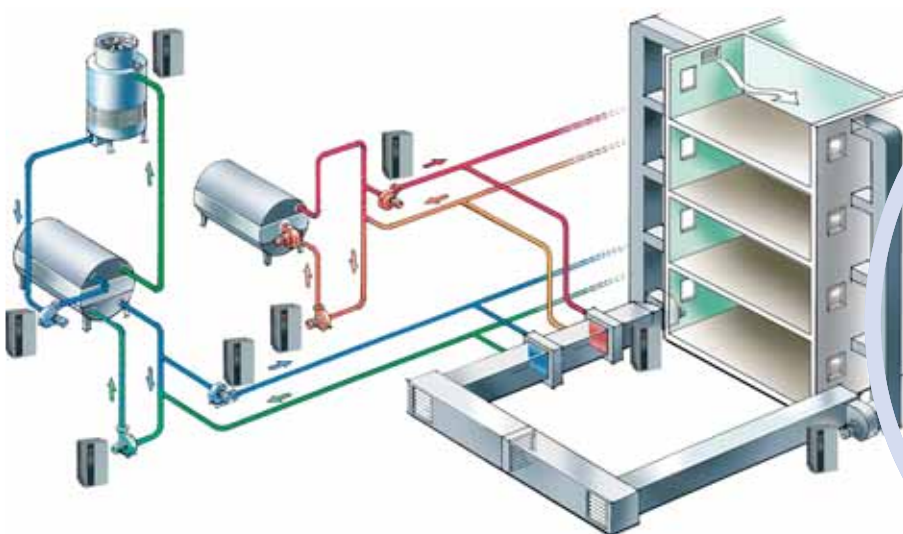

GOAL

efficiency

Our goal is the highest efficiency with the lowest energy consumption and with the lowest overall system cost for our customers = 'The Benefit of Ownership'.

The modular VLT® HVAC Drive – not too much – nor too little

The VLT® HVAC Drive is built on Danfoss' modular concept. Real plug-and-play adding and exchanging of options. Just upgrade instead of buying a new drive.

1 Fieldbus option

- Advanced BACnet
- LonWorks
- Profibus
- PROFINET
- DeviceNet

2 Local Control Panel (LCP)

Choose numerical, graphical or no display

3 I/O option

- General Purpose I/O (3DI + 2AI + 2DO + 1AO)
- Analog I/O option (3AI (0 – 10 V / PT1000 / NI 1000) + 3AO (0 – 10 V))
- Relay output (3 x relays)

4 24 V supply option

5 RFI filter

Built-in RFI filter for long motor cables compliant with the IEC 61800-3 and EN 55011 standards.

6 AC mains disconnect

(Factory mounted option)

7 Input mains option

Various input plate configurations are available including mains switch (disconnect), or RFI filter. Input plates are field adaptable if options need to be added after installation.

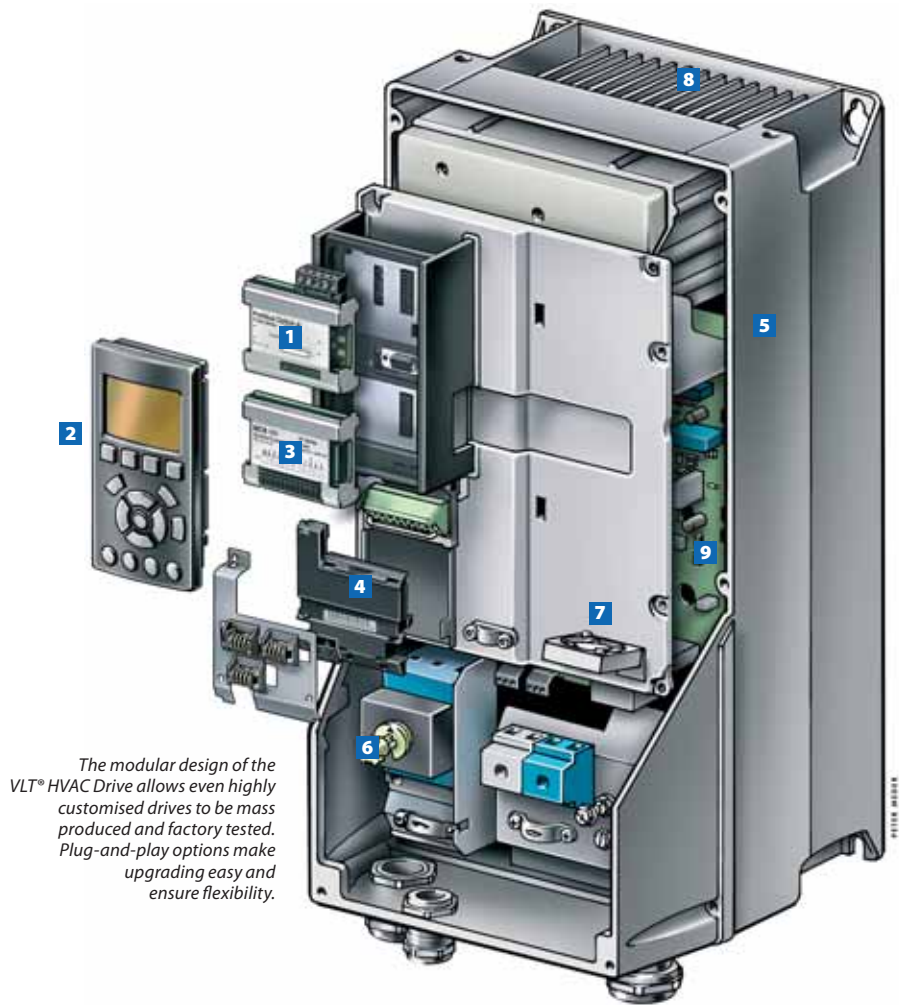

The modular design of the VLT® HVAC Drive allows even highly customised drives to be mass produced and factory tested. Plug-and-play options make upgrading easy and ensure flexibility.

8 Unique cooling concept

- No ambient air flow over the electronics up to 90 kW
- Above 90 kW, designed with back channel cooling (85% heat dissipated via back channel)

9 Durable in aggressive environments

In some HVAC applications, it is recommended to protect the drive with coated PCB's. VLT® HVAC Drive is designed for level 3C2 according to IEC 60721-3-3. Protection level 3C3 is optionally delivered from factory.

This option offers significantly improved protection against chlorine, hydrogen sulphide, ammonia and other corrosive environments.

VLT® quality up to 1.4 MW

The VLT® HVAC Drive is available from 1.1 kW to 1.4 MW.

Danfoss' drive experience since 1968 lies behind the intelligent design of VLT® drives.

All enclosures are mechanically designed with focus on:

- Robustness
- Easy access and installation
- Intelligent cooling
- High ambient temperatures



The VLT® HVAC Drive is hooked-up on your net

The VLT® HVAC Drive integrates and communicates seamlessly with all HVAC devices, mastered by Building Management Systems via the fieldbus. HVAC-specific features make it economical, flexible and user-friendly and make HVAC operation simple.

Improve system performance

VLT® HVAC Drive uses limited network bandwidth, and requires less resources in the DDC controller due to the support of alarm and event notification.

This can reduce traffic by more than 50% compared to other drives.

With VLT® HVAC Drive it is possible to read all the inputs and control all the outputs on I/O options.

This means that when integrating a VLT® HVAC Drive into the control system it is possible to save by requiring fewer physical I/O points.

Detailed information about warnings and alarms

VLT® HVAC Drive has outputs giving detailed information about alarms and warnings. DDC controllers can monitor these and see when an alarm or warning occurs and why it occurred.

Embedded fieldbuses

- Native BACnet
- Modbus RTU (std.)
- FC protocol
- N2 Metasys
- FLN Apogee

Optional fieldbuses

- Advanced BACnet
- LonWorks
- Profibus
- Devicenet

NEW!

- Ethernet



Have BACnet your way

VLT® HVAC Drive comes with an embedded BACnet protocol that makes it suitable for most smaller plants.

For larger plants, more system performance is required.



The VLT® BACnet option is a plug-and-play solution that optimizes the use of VLT® HVAC Drive together with building management systems using the BACnet® fieldbus.

VLT® HVAC Drive has objects defined to accept 3 separate feedbacks transmitted over BACnet.

This option makes it easy to control or monitor points required in typical HVAC applications.

Listed by BTL

The option has passed comprehensive and long-lasting tests at the BTL laboratories, which ensures that the function will work together with any other BTL-listed equipment.



VLT® HVAC drives – optimized for installation in panels

IP 20/Type 1 enclosures

The installation volume and/or the mounting surfaces are reduced by up to 60% compared to the previous VLT® series.

The functionality nevertheless fulfills the highest requirements even for applications with high overload, long motor cables and ambient temperatures up to 50° C (55° C with derating).

Optimized design

Optimized efficiency and intelligent cooling technology make for a compact and service-friendly design. Supplementary equipment such as EMC filters, harmonics suppression and brake modules are integrated into the enclosure.

Save installation time

The IP20/NEMA 1 series is designed for easy accessibility and time-saving installation. Mechanical fastening points are easy to access from the front even with automatic tools.

All terminals are sufficiently dimensioned and clearly marked. One need only loosen a few screws to get to the terminals.

Accessories for bonding screened cables are included. The compact enclosures are easier to install. This is important especially within existing installations with limited accessibility. An extensive range of options and accessories are available, optimizing the drive for the respective application.



Intelligent heat management – variable cooling methods for different benefits

Total separation between cooling air and electronics protects the electronics and allows for installation where heat is removed from outside of the cabinets.

With the VLT® HVAC Drive, a flanged heat sink kit is available for mounting the drive in the backplate of a cabinet, separating the heatsink airflow from the electronics.

Eliminating airflow over the electronics increases drive lifetime as contaminants are excluded from the drive.

Back channel cooling minimizes heat loss increasing energy efficiency, a significant benefit for high power drives.

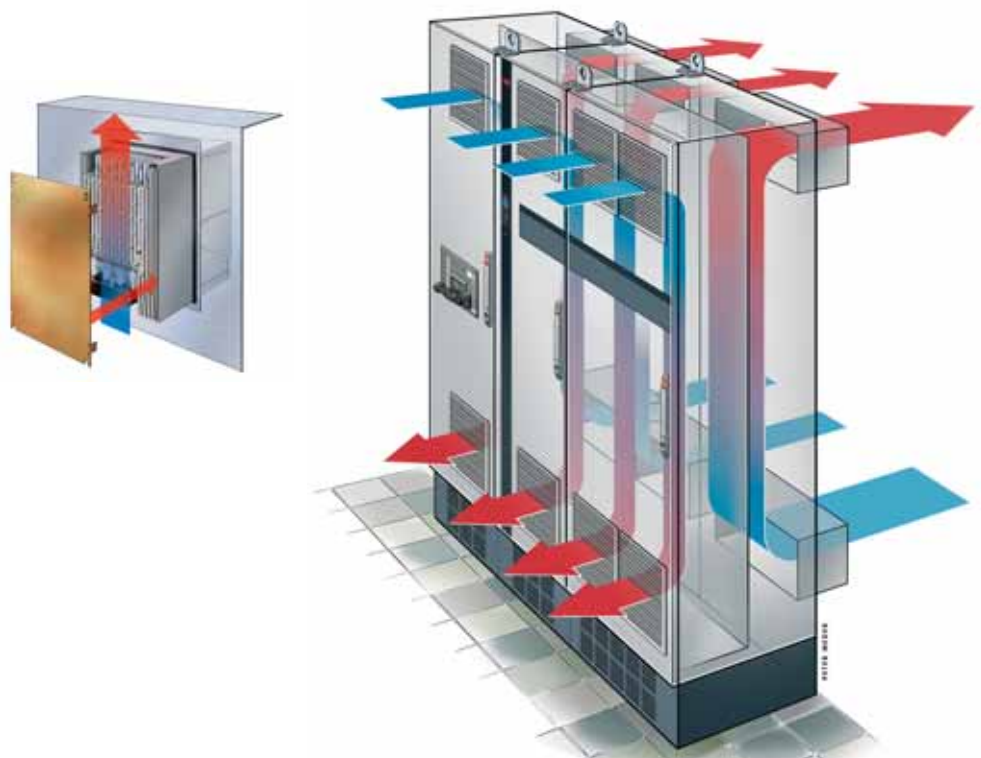

High reliability in any environment



All VLT® HVAC Drive versions have manganese phosphor rear bodies. IP66/Type 4x enclosed drives are suitable for installation in demanding environments (e.g. cooling towers).

Cooling air is kept outside the device to prevent any pollution of the electronics. The surfaces are smooth and easily cleaned.

The IP55/66, Type 4x series are designed for easy accessibility and time-saving installation.

Furthermore, all components such as EMC filters for compliance with EN 55011, class A1/B, as well as the DC coils, are protected inside the drive.

NEW! Type 4x Indoor

VLT® HVAC Drive comes in the extremely tight Type 4x enclosure.

Because of the high-density integration, the tight housings of the VLT® HVAC Drive are significantly smaller when compared to other drives of the same performance.

Motor and power cables are mounted securely through glands in the base plate.



The VLT® HVAC Drive is also available with a mains switch option. This switch interrupts the mains supply and has a free useable auxiliary contact.



An external watertight USB plug connected to the control card inside IP 55/66 enclosures makes USB access easy.



The real effect of VLT® HVAC drives is – money-saving right through the chain



Automatic Energy Optimisation

The standard AEO feature provides optimized motor magnetization at all speeds and loads.

This optimization program increases the energy savings gained by applying variable speed control.

Automatic Motor Adaptation

Enter the name plate data, and VLT® HVAC Drive automatically adjusts to the motor.

Suitable for 'follower' operation

The drive's modular structure makes it suitable for 'follower' operation mastered by BMS, PLC's or DDCs.

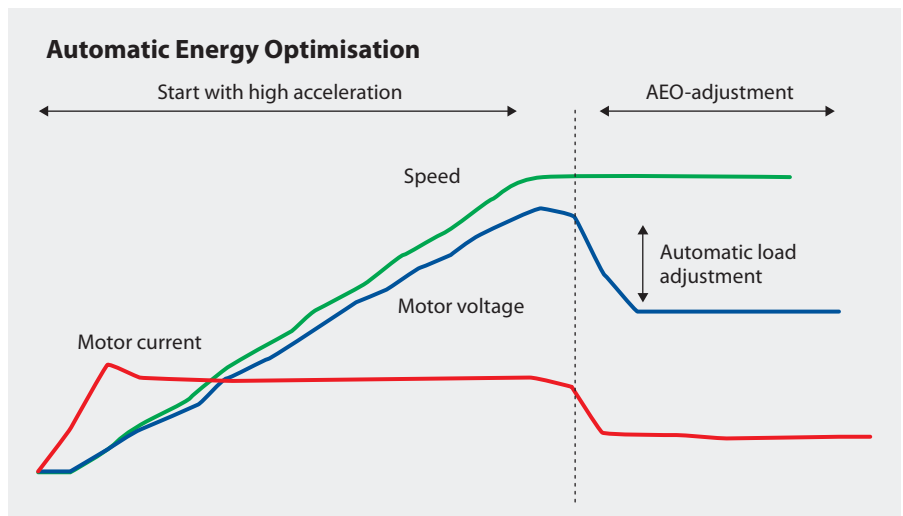

Keeps EMC on the safe side

Optimum EMC protection coupled with integrated harmonic filters ensures that the optimum EMC environment and cleanest power supplies are maintained throughout the operational lifetime of the system, negating any reduction in lifecycle costs.

VLT® HVAC Drive meets the EMC product standard EN 61800-3 without additional external components even when using long motor cables, and corresponds to the EMC guidelines 2004/108/EC, offering performance superior to other drives.

Critical for practical use is compliance with the environment standard

EN 61800-3, class C1 (residential) and Class C2 (industrial area).

C2 ensures reliable plant operation through full compliance with all EMC requirements, product standards, prescribed warnings and restrictions.

Integrated chokes minimise the network effects dramatically and thus maintain operation within the limits of EN 61000-3-12.

These chokes also make the VLT® HVAC Drive stable and highly dynamic even during short supply voltage drops or other poor network conditions.

Clean power supply

VLT® HVAC Drive introduces a minimum of RFI or harmonic pollution into the building and avoids problematic and, in some countries/regions, performance outside of their regulations.

VLT® HVAC Drive is a reliable and cost effective investment.

DC coils reduce harmonic noise and protect the drive. Also EMC filters are integrated (meets EN 55011 A2, A1 or B).



Categories according to EN 61800-3	C1	C2	C3	C4
Limits according to EN 55011	Class B	Class A1	Class A2	Exceeding class A2

Comparison of limits EN 55011/61800-3

Keeps your power supply clean

Harmonic distortion on the supply grid is an increasing problem mainly caused by electronic power devices, including frequency converters, drawing non-sinusoidal current from the mains supply. This creates harmonic distortion on the supply depending on the supply impedance.

Danfoss' Harmonic Calculation Software MCT 31 makes it possible to calculate the extent of these harmonics at the planning stage and can suggest mitigation countermeasures.

Harmonic mitigation can be particularly valuable when the power supply is backed up with emergency generators, which have poorer tolerance to non-sinusoidal currents.

Current standards (EN 50106) are included in the software analysis

tool which can quickly and easily be downloaded from Danfoss website.

Data can be entered, stored and recalled project by project. At a click

the software presents a clear overview of each project with data presented in both tabular and bar-chart formats.

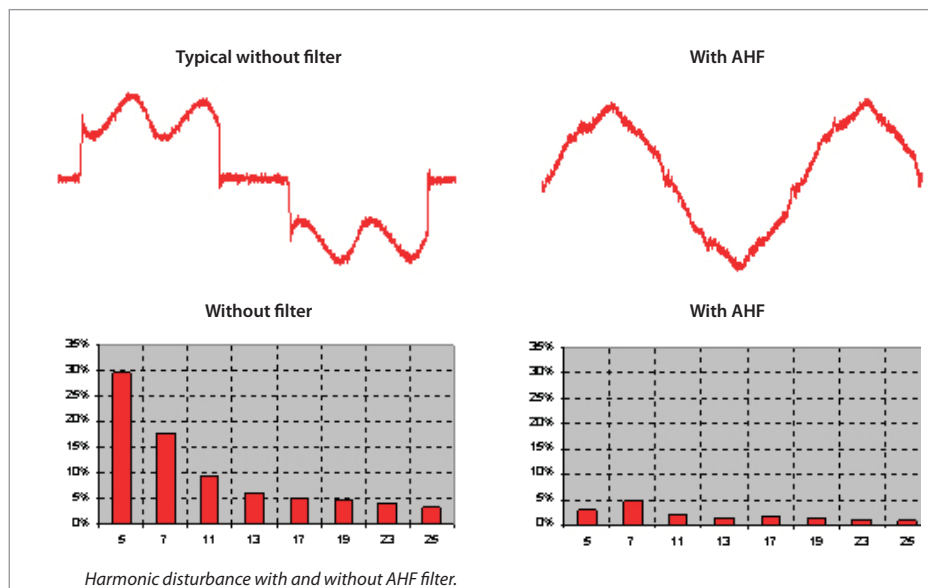

The common approach to drive programming

1 Graphical display

- International letters and signs
- Graphical display with bar-charts
- Easy overview
- 27 languages selection
- iF awarded design

2 Menu structure

- Based on the well known matrix system in today's VLT® drives
- Easy shortcuts for the experienced user
- Edit and operate in different set-ups simultaneously

3 Other benefits

- Demountable during operation
- Upload and download functionality
- IP 65/NEMA 4 rating when panel door mounted. (A remote mounting kit is available)
- Up to 5 different variables visible at a time
- Manual speed/torque setting
- 100% user defined information and size



4 Illumination

- Relevant buttons are illuminated when active
- LEDs indicate the status of the drive

5 Quick Menus

- A Danfoss-defined Quick Menu
- A user-defined Quick Menu
- A Changes Made menu lists the parameters unique to your application
- A Function Setup menu provides quick and easy set-up for specific applications
- A Logging menu provides access to operation history

6 Intuitive functions

- Info ('on board manual')
- Cancel ('undo')
- Alarm log (quick access)

The user interface may be mounted remotely on a control panel fascia, eliminating the need for additional switches and instrumentation.

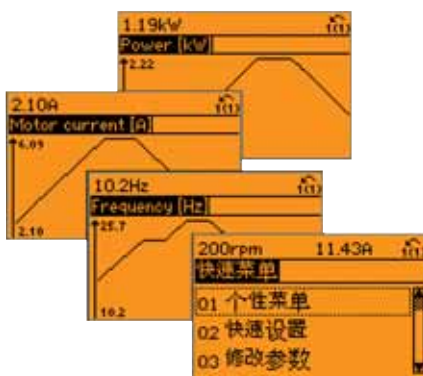

Three panel options: Graphical, numerical, blind cover.

The VLT® HVAC Drive is controlled locally via a control panel. This is plugged in directly or connected via a cable.

The VLT® HVAC Drive can be remote-commissioned and monitored via a USB cable or fieldbus communication. Special software is available: Wizards, Data transfer tool, VLT® Set-up Software MCT 10, and Language changer.



New! Smart Start

Saves commissioning time

Smart Start guides you through 10 basic steps for commissioning the VLT® drive and ensures a quick, safe and energy saving commissioning.

Smart Start is activated at the first power up, after a factory reset, or from the quick menu.

When activating the Smart Start feature, the drive will ask for the information it needs to run the application.

Smart Start will require the following information:

- Number of motors connected
- Thermal protection, yes/no
- Nominal motor frequency
- Motor voltage

- Total motor power
- Total motor current
- Nominal motor speed
- Minimum reference
- Maximum reference
- Application: Fan, pump or compressor

The Smart Start also asks if you want to apply the VLT® Automatic Motor Adaptation (AMA) and the Automatic Energy Optimisation (AEO) features. The Smart Start will be deactivated when the drive is programmed via bus or fieldbus and after a timeout.

NOTE: The Smart Start will only be active if you choose the graphical control panel.

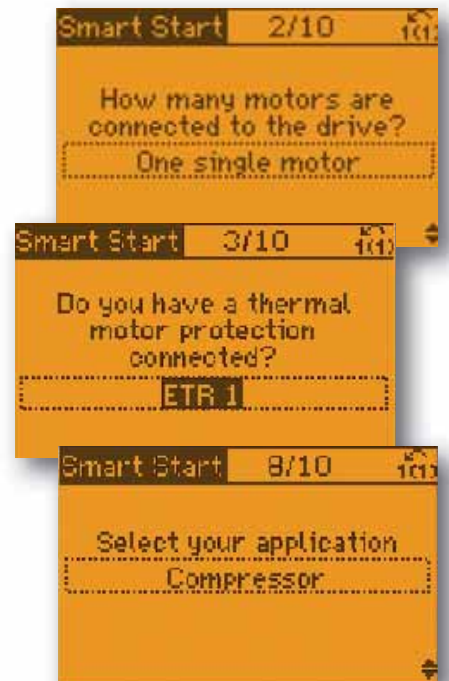

VLT® Motion Control Tool

The real effect is money saved

Free MCT 10 set-up software provides easy control of details as well as a general overview of drive systems, large or small. The tool handles all drives-related data.

Explorer-like interface

The MCT 10 software features explorer-like interface design and functionality to ease both use and learning of the facilities.

More efficient service organisation

- Scope & logging: analyze problems easily
- Read out alarms, warnings and fault log in one view
- Compare a saved project with an on-line drive

More efficient commissioning

- Off-line commissioning off-site
- Save/send/mail projects anywhere
- Easy fieldbus handling, multiple drives in project file. Enables the service organization to be more efficient

Basic

- Scope & Graph
- Alarm history in saved projects
- Graphical Timebased Actions, Preventive Maintenance and Basic Cascade Controller
- Multiple fieldbus support

Advanced

- No limitation in the number of drives
- Motor database
- Real-time logging from the drive
- Sensorless pump control

On-line and off-line mode

In the on-line mode, you work with the actual set-up of the drives in question. Your actions will have immediate effect on the performance of the drive(s).

Connections

- USB
- RS485

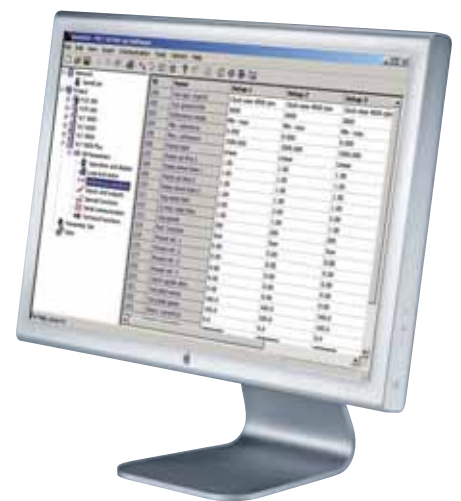

Project oriented

In project mode you work with the drive parameters as a 'virtual' set-up. This allows you to adjust the whole system before you implement it into the drives and put it in action. In project mode you can set the system up even before the drives are installed. A single command will update the whole system. In case a drive is exchanged, it is easily set up to perform exactly as its predecessor.

Enhanced safety built-in

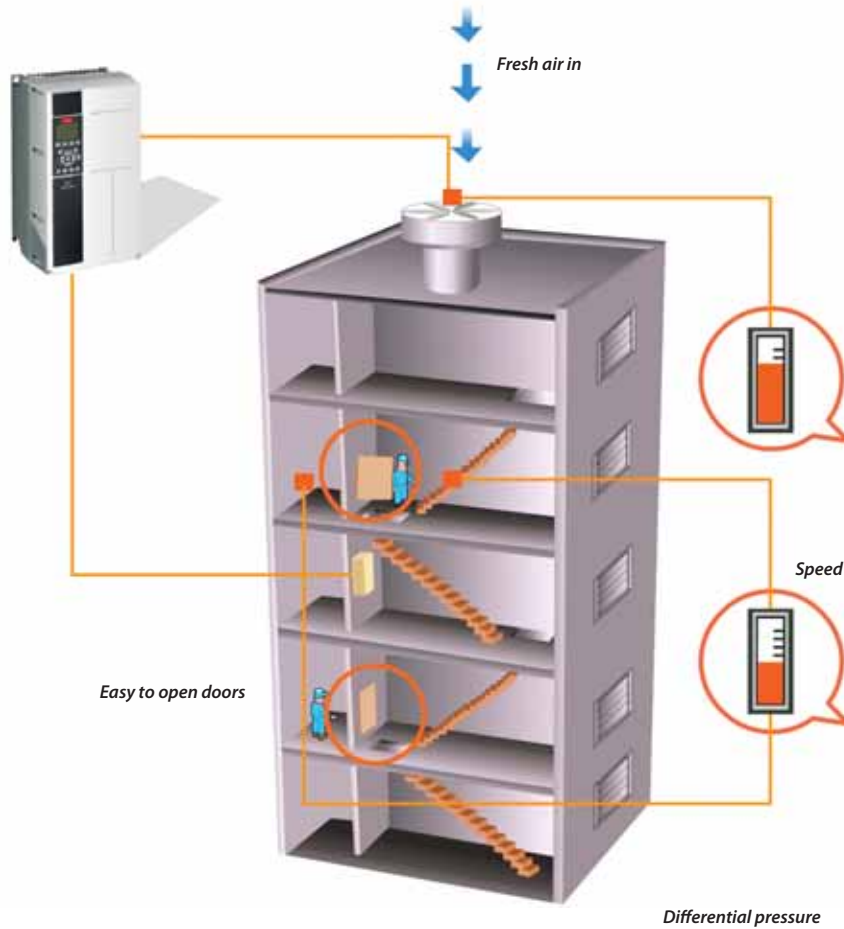

Mains switch option

This switch interrupts the mains supply and has a free useable auxiliary contact. The mains switch ensures the safety of staff during maintenance and cleaning operations.

The mains switch option also reduces assembly cost.



Fire Override Mode

Activating the function 'Fire-mode' within the VLT® drive ensures secure and continued operation within applications such as stair-well pressurization, car park exhaust fans, smoke exhaust and essential service functions.

Clearly indicated

Fire mode is clearly indicated on the VLT® display to prevent any confusion. When set, the drive will override self protection and will continue operation despite the possibility of permanent damage in case of overheating or overload. The vital goal is to keep the motor running even if it means self-destruction.

Drive bypass

If a drive bypass is available, the VLT® HVAC Drive will not only sacrifice itself

in case of an extreme condition, but is able to bypass itself and connect the motor directly to the mains. This will maintain operation as long as power is provided and the motor is functioning.

Safe Stop

The VLT® HVAC Drive comes standard with the safe stop functionality. The solution is approved by authorities for category 3 installations in accordance with EN 954-1. This feature prevents the drive from unintended starts.

Thermistor card

With the PTC Thermistor Card MCB 112 the Danfoss VLT® HVAC Drive offers improved surveillance of the motor condition compared to the built-in ETR function and thermistor terminal.

Dedicated fan features

User-friendly, distributed intelligence and reduced power consumption are beneficial for fan applications.

Velocity-to-flow conversion

The VLT® HVAC Drive is able to convert velocity pressure sensor values into flow values. Operators can therefore set the drive up to provide a fixed flow or fixed differential flow. This way both comfort and energy consumption are optimized. Using a pressure sensor instead of a flow sensor saves money.

Intelligent AHU functions

The VLT® HVAC Drive handles logical rules and inputs from sensors, real-time functionality, and time-related actions. This enables the HVAC Drive to control a wide range of functions, including:

- Weekend and working-day operations
- Cascaded P-PI for temperature control
- Multi-zone '3' control
- Flow balancing between fresh and outlet air
- Belt monitoring

Fire Override Mode

Fire Override Mode prevents the VLT® HVAC Drive from stopping for self-protection reasons. In this mode it will maintain vital fan operation regardless of control signals, warnings or alarms.

Extends BMS capacity

When integrated into the BMS network, all the HVAC Drive I/O points are available as remote I/O to extend the capacity of the BMS. For example, room temperature sensors (Pt1000/ Ni1000) can be directly connected.

With the VLT® Sensor Input Card option the motor is protected from overheating of the bearings and windings. The individual sensor temperature is visible as a read-out in the display or by fieldbus.

Resonance Monitoring

By pressing a few buttons on the Local Control Panel, the drive can be set to avoid frequency bands at which connected fans create resonances in the ventilation system. This reduces vibration noise and wear-and-tear on equipment.

Stairwell Pressurisation

In the event of fire, the VLT® HVAC Drive can maintain a higher level of air pressure in stairwells than in other parts of the building and ensure that fire escapes remain free of smoke.

Lower AHU costs

The VLT® HVAC Drive is fitted with a built-in Smart Logic Controller and four auto-tune PID controllers and can control air handling functions with fans, valves and dampers. The building management's DDC tasks are reduced and valuable data points (DP) are free for other use.

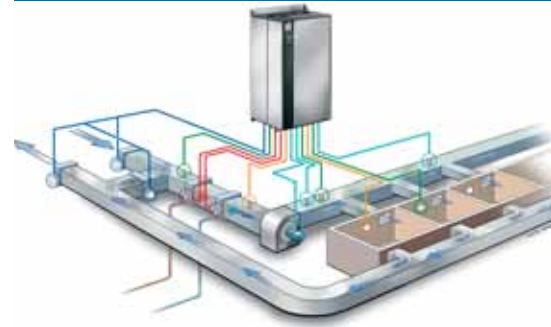

4 x PID controller

(Individual set-points/feed-backs)

- 1 PID for closed loop control of the motor connected to the drive
- 3 PIDs for external closed loop control of HVAC equipment
- Auto-tuning of all 4 PID loops
- Eliminates the need for other controllers
- Provides flexibility for the BMS and reduces the load on the central BMS

The drive controller uses an input sensor that measures pressure, temperature or other variables to change the speed of the motor connected to the VLT® HVAC Drive, by adjusting the output frequency to match the varying load.

The additional 3 PID controllers can be used for external sensors (i.e. pressure, temperature, flow) to control heating/cooling coil valves, outside/return/exhaust dampers or other external HVAC components.



Dedicated pump features



The VLT® HVAC Drive offers a vast number of pump-specific features developed in cooperation with OEMs, contractors and manufacturers around the world.

Embedded Pump Cascade Controller

The Pump Cascade Controller distributes running hours evenly across all pumps, keeps wear-and-tear on individual pumps to a minimum and ensures that all pumps are in great shape.

Vital water supply

Vital water supply can be assured in the event of leakage or a broken pipe. For example, overload is prevented by reducing drive speed – and supply is secured at lower flow.

Sleep Mode

In Sleep Mode the drive detects situations with low or no flow. Instead of continuous operation, sleep mode boosts the system pressure and then stops to save energy. The drive starts automatically when the pressure falls below the lower set point.

1 Dry Pump Protection and End of Curve

Dry Pump Protection and End of Curve relate to situations where the pump runs without creating the desired pressure – as when a well runs dry or a pipe leaks. In this situation the drive sets off an alarm, shuts off the pump, or performs another pre-programmed action.

2 Auto tuning of the PI controllers

With auto tuning of the PI controllers, the drive monitors how the system reacts to corrections made by the drive, learns from it, and calculates the 'P' and 'I' values so that precise and stable operation is achieved quickly.

This applies to each PI controller in the 4-menu sets individually. Exact P and I settings at start-up will not be necessary – which lowers commissioning costs.

3 Flow compensation

Significant energy savings and reduced installation costs are provided by flow compensation in both fan and pump systems. A pressure sensor mounted close to the fan or pump provides a reference enabling pressure to be kept constant at the discharge end of the system. The drive constantly adjusts the pressure reference to follow the system curve.

4 No/low flow

An operating pump will normally consume more power the faster it runs – according to a curve determined by the pump and application design. The VLT® HVAC Drive will detect situations where the pump runs fast but is not fully loaded – and thereby not consuming adequate power. This is the case when water circulation stops, the pump runs dry, or when pipes leak.

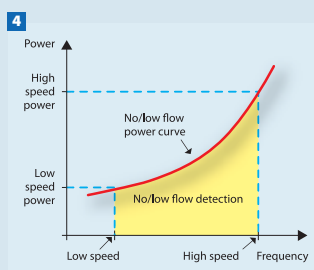
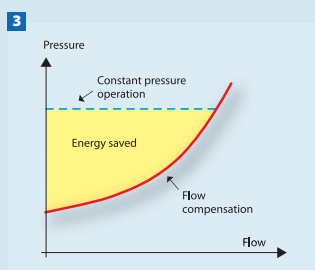
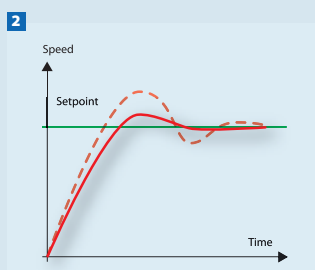
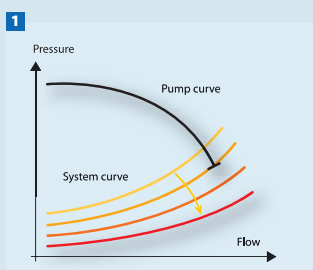

Dedicated compressor features



Premium torque control

The VLT® HVAC Drive has been designed to offer flexible, intelligent control of compressors, making it even easier to optimize cooling capacity with constant temperature and pressure levels for water chillers, and other typical compressor applications in HVAC.

Replace a cascade with a single compressor

The VLT® HVAC Drive provides the same level of flexibility with one large compressor instead of a cascade of 2 or 3 smaller compressors. The VLT® HVAC Drive operates all compressors at a far more refined range of speeds than normal – even above nominal speed – meaning that one large compressor is sufficient.

Alternatively, use the built-in cascade controller to operate the lead compressor with variable speed, while using the VLT® HVAC Drive to manage on/off control of up to two additional compressors.

Set point in temperature

The VLT® HVAC Drive calculates the actual refrigerant temperature from the measured pressure and refines compressor operation accordingly, using the built-in PID controller.

The temperature setpoint for this calculation is set in degrees via the Local Control Panel or MCT 10 – and not as a pressure value.

Fewer starts and stops

A maximum number of start/stop cycles within a given period of time can be set via the LCP or MCT10. Since start-up is the most critical part of compressor operation this extends compressor life.

Quick start-up

The VLT® HVAC Drive offers a feature to open a bypass valve and let the compressor start quickly without load.

The VLT® HVAC Drive provides increased breakaway torque and can give 110% torque for 60 seconds in normal operation.

Improving energy efficiency ... continuously

Traditional commercial air conditioning systems are designed for efficient operation at peak-load conditions, so systems are actually oversized about 85% of the time or more. Consequently, at part load conditions, the systems has excess capacity, with significant and costly energy waste. Variable speed will contribute to a higher COP and lower energy consumption with the load matched to actual demand while delivering a solid return on investment (ROI).

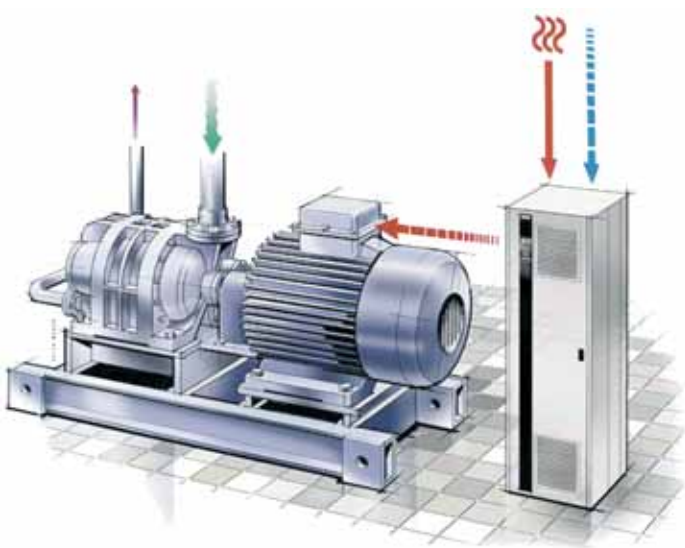

VLT® HVAC Drive projects



Dubai Metro

Danfoss Drives delivered a total of 260 drives rated from 90 to 325 kW for the new metro in Dubai, United Arab Emirates, to operate exhaust fans and tunnel ventilation. Dubai Metro is projected to carry approximately 1.2 million passengers on an average day, and 355 million passengers per year.



Tropical Islands Resort near Berlin, Germany

A steady 25° C air temperature, 31° C water temperature, no rain, and a pleasant 40% to 60% humidity for the resort's tropical plants. Everyone's idea of perfect weather! All this is possible with a first class climate and water control system driven by VLT® HVAC Drives.



Opera House in Sydney, Australia

The Sydney Opera House is one of the architectural wonders of the world, and perhaps the best known building of the 20th century. In 2001, the NSW Government provided \$69 million for several projects to improve the facilities and environment for performing arts companies, patrons and visitors. Danfoss provided the drives.



Shanghai General Motors, China

Shanghai General Motors Co Ltd. is a 50-50% joint venture between General Motors and the Shanghai Automotive Industry Corporation Group (SAIC). Shanghai GM has an annual production capacity of 200,000 vehicles. Danfoss provided the VLT® HVAC drives to maintain the production environment.



Torre Mayor, Mexico City

With its 55 floors and a height of 225 m the Torre Mayor is the highest building in Latin America. Danfoss drives control the heating and ventilation.



Crowne Plaza Copenhagen Towers in Ørestad, Denmark

Copenhagen's latest luxury hotel, the elegant Crowne Plaza Copenhagen Towers in Ørestad, has been designed from the ground upwards with sustainability in mind. VLT® HVAC Drives are a natural part of the solution.

Specifications

(Basic unit without extensions)

Main supply (L1, L2, L3)	
Supply voltage	200 – 240 V ±10%
Supply voltage	380 – 480 V ±10%
Supply voltage	525 – 600 V ±10%
Supply voltage	525 – 690 V ±10%
Supply frequency	50/60 Hz
Displacement power factor (cos φ) near unity	> 0.98
Switching on input supply L1, L2, L3	1–2 times/min.
Harmonic disturbance	Meets EN 61000-3-12

Output data (U, V, W)	
Output voltage	0 – 100% of supply voltage
Output frequency	0–1000 Hz
Switching on output	Unlimited
Ramp times	1 – 3600 sec.

Digital inputs	
Programmable digital inputs	6*
Changeable to digital output	2 (terminal 27, 29)
Logic	PNP or NPN
Voltage level	0 – 24 V DC
Maximum voltage on input	28 V DC
Input resistance, Ri	Approx. 4 kΩ
Scan interval	5 ms

* 2 can be used as digital outputs

Analog inputs	
Analogue inputs	2
Modes	Voltage or current
Voltage level	0 to +10 V (scaleable)
Current level	0/4 to 20 mA (scaleable)
Accuracy of analog inputs	Max. error: 0.5% of full scale

Pulse inputs	
Programmable pulse inputs	2*
Voltage level	0 – 24 V DC (PNP positive logic)
Pulse input accuracy (0.1 – 1 kHz)	Max. error: 0.1% of full scale

* Utilize some of the digital inputs

Digital outputs	
Programmable digital/pulse outputs	2
Voltage level at digital/frequency output	0 – 24 V DC
Max. output current (sink or source)	40 mA
Maximum output frequency at frequency output	0 to 32 kHz
Accuracy on frequency output	Max. error: 0.1% of full scale

Analogue output	
Programmable analogue outputs	1
Current range at analogue output	0/4 – 20 mA
Max. load to common at analogue output (clamp 30)	500 Ω
Accuracy on analogue output	Max. error: 1% of full scale

Control card	
USB interface	1.1 (Full Speed)
USB plug	Type "B"
RS485 interface	Up to 115 kBaud
Max. load (10 V)	15 mA
Max. load (24 V)	200 mA

Relay output	
Programmable relay outputs	2
Max. terminal load (AC) on 1-3 (break), 1-2 (make), 4-6 (break) power card	240 V AC, 2 A
Max. terminal load (AC) on 4-5 (make) power card	400 V AC, 2 A
Min. terminal load on 1-3 (break), 1-2 (make), 4-6 (break), 4-5 (make) power card	24 V DC 10 mA, 24 V AC 20 mA

Surroundings/external	
Enclosure	IP: 00/20/21/54/5566 UL Type: Chassis/1/12/4x Outdoor
Vibration test	1.0 g (D, E & F-enclosures: 0.7 g)
Max. relative humidity	5% – 95% (IEC 721-3-3; Class 3K3 (non-condensing) during operation)
Ambient temperature	Max. 50° C w/o derating
Galvanic isolation of all	I/O supplies according to PELV
Aggressive environment	Designed for coated/uncoated 3C3/3C2 (IEC 60721-3-3)

Fieldbus communication	
Standard built-in: FC Protocol N2 Metasys FLN Apogee Modbus RTU BACnet (embedded)	Optional: LonWorks (MCA 108) BACnet (MCA 109) Profibus (MCA 101) DeviceNet (MCA 104)

Protection mode for longest possible up-time	
– Electronic thermal motor protection against overload	
– Temperature monitoring of the heatsink ensures that the frequency converter trips if the temperature reaches 95° C ± 5° C.	
– The frequency converter is protected against short-circuits on motor terminals U, V, W.	
– The frequency converter is protected against earth faults on motor terminals U, V, W.	
– Protection against mains phase loss	



Power, currents and enclosures

FC 102	kW	T2 200 – 240 V				T4 380 – 480 V						T6 525 – 600 V				T7 525 – 690 V				
		Amp.	IP 20/Chassis	IP 21/Type 1	IP 55/Type 12	IP 66/Type 12	Amp.		IP 00/Chassis	IP 20/Chassis	IP 21/Type 1	IP 54/Type 12	IP 55/Type 12	IP 66/Type 12	Amp.		IP 20/Chassis	IP 21/Type 1	IP 55/Type 12	IP 66/Type 12
							≤440 V	>440 V							≤550 V	>550 V				
P1K1	1.1	6.6					3	2.7						2.6	2.4					
P1K5	1.5	7.5	A2	A2	A4/A5	A4/A5	4.1	3.4	A2	A2				2.9	2.7	A3	A3	A5	A5	
P2K2	2.2	10.6					5.6	4.8						4.1	3.9					
P3K0	3	12.5	A3	A3	A5	A5	7.2	6.3						5.2	4.9					
P3K7	3.7	16.7																		
P4K0	4.0						10	8.2	A2	A2				6.4	6.1					
P5K5	5.5	24.2					13	11	A3	A3				9.5	9	A3	A3	A5	A5	
P7K5	7.5	30.8	B3	B1	B1	B1	16	14.5						11.5	11					
P11K	11	46.2					24	21	B3	B1				19	18					
P15K	15	59.4	B4	B2	B2	B2	32	27						23	22	B3	B1	B1	B1	
P18K	18	74.8					37.5	34	B4	B2				28	27					
P22K	22	88	C3	C1	C1	C1	44	40						36	34					
P30K	30	115					61	52	B4	B2				43	41	B4	B2	B2	B2	
P37K	37	143	C4	C2	C2	C2	73	65						54	52					
P45K	45	170					90	80	C3	C1				65	62	C3	C1	C1	C1	56
P55K	55						106	105						87	83					54
P75K	75						147	130	C3	C1				105	100	C4	C2	C2	C2	76
P90K	90						177	160	C4	C2				137	131					73
P110	110						212	190												90
P132	132						260	240	D3		D1	D1								86
P160	160						315	302												113
P200	200						395	361	D4		D2	D2								108
P250	250						480	443												137
P315	315						600	540												131
P355	355						658	590												162
P400	400						745	678	E2		E1	E1								155
P450	450						800	730												201
P500	500						880	780												192
P560	560						990	890			F1/F3	F1/F3								253
P630	630						1120	1050												242
P710	710						1260	1160												303
P800	800						1460	1380			F2/F4	F2/F4								290
P900	900																			360
P1M0	1000						1720	1530												418
P1M2	1200																			400
P1M4	1400																			450

IP 00/Chassis	IP 20/Chassis	IP 21/Type 1	With upgrade kit	IP 54/Type 12	IP 55/Type 12	IP 66/Type 4x Outdoor
---------------	---------------	--------------	------------------	---------------	---------------	-----------------------

Dimensions [mm]

	A2	A3	A4	A5	B1	B2	B3	B4	C1	C2	C3	C4	D1	D2	D3	D4	E1	E2	F1	F2	F3	F4
H	268	390	420	480	650	399	520	680	770	550	660	1209	1589	1046	1327	840	831	2324	2324	2324	2324	2324
W	90	130	200	242	165	230	308	370	308	370	308	370	420	408	408	2197	1705	1569	1962	2159	2159	2159
D	205	175	200	260	249	242	310	335	333	380	375	736	736	927	927	927	927	927	927	927	927	927
H+	375				475	670			755	950												
W+	90	130			165	255			329	391												

Note: H and W dimensions are with back-plate. H+ and W+ are with IP upgrade kit. D dimensions are without option. A or B for A2 and A3.

Ordering type code for VLT® HVAC Drive

[1] [2] [3] [4] [5] [6] [7] [8] [9] [10] [11] [12] [13] [14] [15] [16] [17] [18]
 FC-102 - [] - [] - [] - [] - [] - [] - [] - [] - [] - X - SXX X - X - [] - [] - CX - X - XX - []

[1] Application

102 VLT® HVAC Drive FC 102

[2] Power Size

- P1K1
- P1K5
- P2K2
- P3K0
- P3K7
- P4K0
- P5K5
- P7K5
- P11K
- P15K
- P18K
- P22K
- P30K
- P37K
- P45K
- P55K
- P75K
- P90K
- P110
- P132
- P160
- P200
- P250
- P315
- P355
- P400
- P450
- P500
- P560
- P630
- P710
- P800
- P900
- P1M0
- P1M2
- P1M4

See ratings data on page 22 for power ratings

[3] AC Line Voltage

T2	3 x 200/240 V AC (1.1 – 45 kW)
T4	3 x 380/480 V AC
T6	3 x 525/600 V AC (1.1 – 90 kW)
T7	3 x 525/690 V AC (45 kW – 1.2 MW)

[4] Enclosure

- For cabinet mounting:
- E00 IP 00/Chassis (enclosure D3, D4)
 - E20 IP 20/Chassis (encl. A2, A3, B3, B4, C3, C4)
- Standalone:
- E21 IP 21/Type 1 (encl. B1, B2, C1, C2, D1, D2, E, F)
 - E54 IP 54/Type 12 (encl. D1, D2, E, F)
 - E55 IP 55/Type 12 (encl. A5, B1, B2, C1, C2)
 - E66 IP 66/Type 4x Outd. (encl. A5, B1, B2, C1, C2)
- Special designs:
- C00 IP 00/Chassis (encl. E00 – air duct in stainless steel)
 - P20 IP 20/Chassis (encl. B4, C3, C4 – Back Plate)
 - E2M IP 21/Type 1 (encl. D1, D2 – protective cover)
 - P21 IP 21/Type 1 (encl. as E21 – Back Plate)
 - E5M IP 54/Type 12 (encl. D1, D2 – protective cover)
 - P55 IP 55/Type 12 (encl. as E55 – Back Plate)

[5] RFI Filter (EN 55011)

- H1 RFI-Filter Class A1/B (A, B, C)
- H2 RFI-Filter, Class A2 (A, B, C, D, E, F)
- H3 RFI-Filter Class A1/B (A, B, C)
- H4 RFI-Filter, Class A1 (D, E, F)
- H6 RFI-Filter for Marine
- HX No RFI-Filter (A, B, C, 525 – 600 V)

[6] Braking & Safety

- X No brake IGBT
- B Brake IGBT mounted
- T Safe stop without brake
- U With brake and Safe Stop

[7] Display (Local Control Panel)

- X Blank faceplate, no LCP installed
- G LCP 102 – Graphic LCP installed
- N LCP 101 – Numeric LCP installed

[8] Conformal Coating (IEC 721-3-3)

- X No conformal coating
- C Conformal coating on all PCBs

[9] Mains Input

- X No option
- 1 Mains disconnect
- 3 Mains disconnect and fuses
- 5 Mains disconnect, fuses and load sharing
- 7 Fuses
- A Fuses & load sharing terminals
- D Load sharing terminals

[10] Cable

- X Standard Cable Entries
- O Metric Cable Entries
- S US cable entries

[13] A Option (Fieldbus)

- AX No fieldbus option
- A0 MCA 101 – Profibus DPV1
- A4 MCA 104 – DeviceNet
- AG MCA 108 – LonWorks
- AJ MCA 109 – BACnet

[14] B Option (Application)

- BX No application option
- BK MCB 101 – General Purpose I/O
- BP MCB 105 – Relay Expansion
- B0 MCB 109 – Analogue I/O
- B2 MCB 102 – PTC Thermistor Card

[18] D Option (Control Power Backup Input)

- DX No DC input installed
- D0 MCB 107 24 VDC backup input

Please beware that not all combinations are possible. Find help configuring our drive with the online configurator found under: [driveconfig at Danfoss website.](#)

Based on your selection, Danfoss manufactures the desired VLT® HVAC Drive to your specification. You will receive a fully assembled frequency converter, tested under full load conditions.



Connection examples

The numbers represent the terminals on the drive

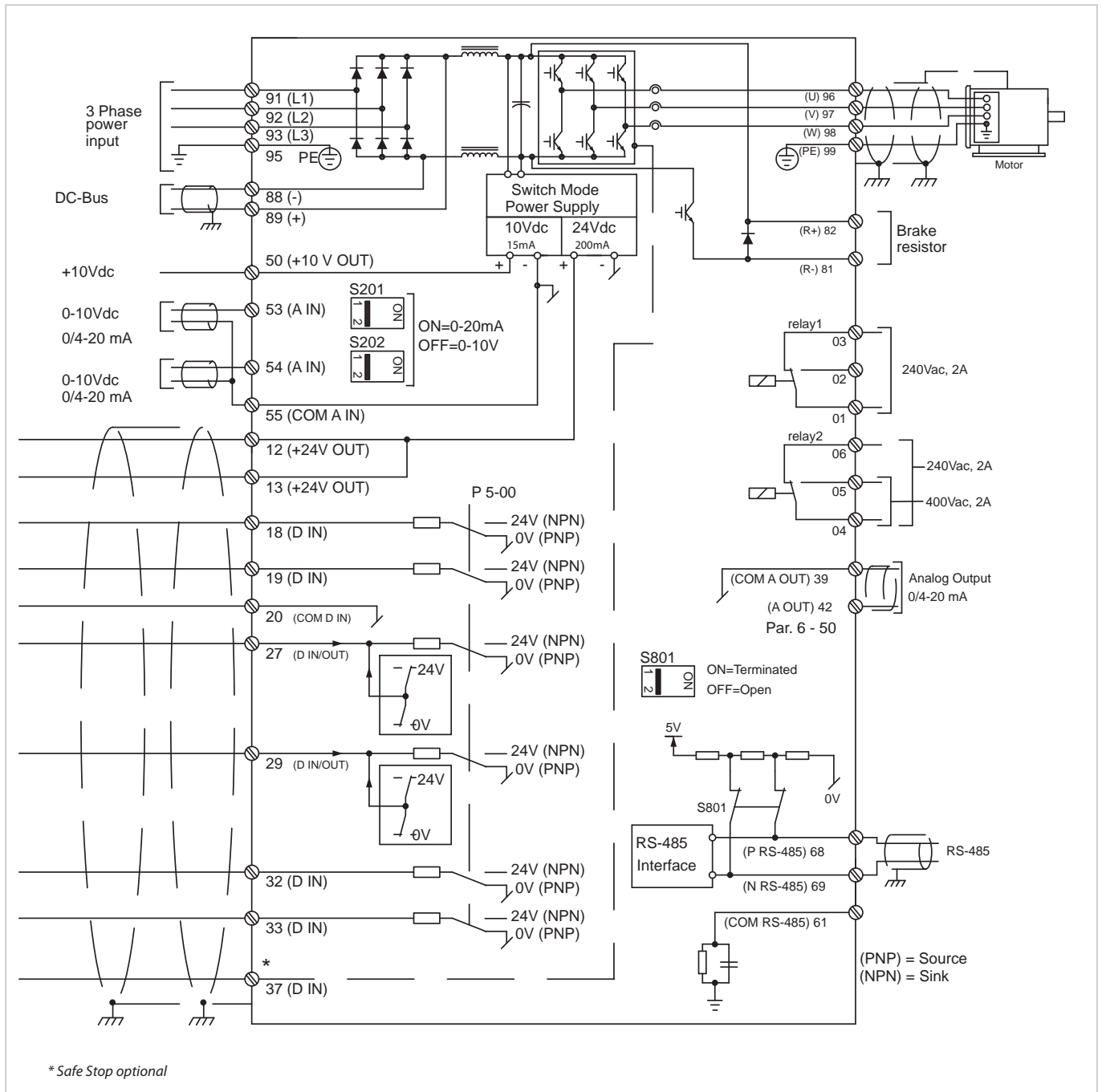

This diagram shows a typical installation of the VLT® HVAC Drive. Power is connected to the terminals 91 (L1), 92 (L2) and 93 (L3) and the motor is connected to 96 (U), 97 (V) and 98 (W).

Terminals 88 and 89 are used for load sharing between drives. Analogue inputs can be connected to

the 53 (V or mA), and for 54 (V or mA) terminals. These inputs can be set up as either reference, feedback or thermistor inputs.

There are 6 digital inputs to be connected to terminals 18, 19, 27, 29, 32, and 33. Two digital input/output terminals (27 and 29) can be set up

as digital outputs to show an actual status or warning. The terminal 42 analogue output can show process values such as 0 - I^{max} .

On the 68 (P+) and 69 (N-) terminals' RS 485 interface, the drive can be controlled and monitored via serial communication.

200 – 240 VAC

Enclosure	IP 20 (IP 21*)/Chassis(Type 1)		A2			A3		
	IP 55 + IP 66 /NEMA 12		A4 + A5			A5		
			P1K1	P1K5	P2K2	P3K0	P3K7	
Typical Shaft Output		[kW]	1.1	1.5	2.2	3	3.7	
Typical Shaft Output at 208 V		[HP]	1.5	2.0	2.9	4.0	4.9	
Output Current (3 x 200 – 240 V)	Continuous	[A]	6.6	7.5	10.6	12.5	16.7	
	Intermittent	[A]	7.3	8.3	11.7	13.8	18.4	
Output Power (208 V AC)	Continuous	[kVA]	2.38	2.70	3.82	4.50	6.00	
Max. cable size (Mains, motor, brake)		[mm ²] ([AWG])	4 (10)					
Max. Input Current (3 x 200 – 240 V)	Continuous	[A]	5.9	6.8	9.5	11.3	15.0	
	Intermittent	[A]	6.5	7.5	10.5	12.4	16.5	
Max. pre-fuses		[A]	20	20	20	32	32	
Environment								
Estimated power loss at rated max. load		[W]	63	82	116	155	185	
Weight								
IP 20		[kg]	4.9	4.9	4.9	6.6	6.6	
IP 21		[kg]	5.5	5.5	5.5	7.5	7.5	
IP 55, IP 66		[kg]	13.5	13.5	13.5	13.5	13.5	
Efficiency			0.96	0.96	0.96	0.96	0.96	

Enclosure	IP 20 (IP 21*)/Chassis(Type 1)		B3			B4		C3		C4	
	IP 21/Type 1, IP 55 + IP 66/Type 12		B1			B2	C1		C2		
			P5K5	P7K5	P11K	P15K	P18K	P22K	P30K	P37K	P45K
Typical Shaft Output		[kW]	5.5	7.5	11	15	18.5	22	30	37	45
Typical Shaft Output at 208 V		[HP]	7.5	10	15	20	25	30	40	50	60
Output Current (3 x 200 – 240 V)	Continuous	[A]	24.2	30.8	46.2	59.4	74.8	88.0	115	143	170
	Intermittent	[A]	26.6	33.9	50.8	65.3	82.3	96.8	127	157	187
Output Power (208 V AC)	Continuous	[kVA]	8.7	11.1	16.6	21.4	26.9	31.7	41.4	51.5	61.2
Max. cable size Mains, motor, brake		[mm ²] ([AWG])	10 (7)			35 (2)	50 (1/0) (B4 = 35 (2))		95 (4/0)	120 (250 MCM)	
Max. cable size mains With mains disconnect switch included		[mm ²] ([AWG])	16 (6)			35 (2)	35 (2)		70 (3/0)	185 (kcmil 350)	
Max. Input Current (3 x 200 – 240 V)	Continuous	[A]	22.0	28.0	42.0	54.0	68.0	80.0	104.0	130.0	154.0
	Intermittent	[A]	24.2	30.8	46.2	59.4	74.8	88.0	114.0	143.0	169.0
Max. pre-fuses		[A]	63	63	63	80	125	125	160	200	250
Environment											
Estimated power loss at rated max. load		[W]	269	310	447	602	737	845	1140	1353	1636
Weight											
IP 20		[kg]	12	12	12	23.5	23.5	35	35	50	50
IP 21, IP 55, IP 66		[kg]	23	23	23	27	45	45	45	65	65
Efficiency			0.96	0.96	0.96	0.96	0.96	0.97	0.97	0.97	0.97

* (A2, A3, B3, B4, C3 and C4 may be converted to IP21/Type 1 using a conversion kit.
(Please see also items Mechanical mounting in Operating Instructions and IP 21/ Type 1 Enclosure kit in the Design Guide.))

380 – 480 VAC

Enclosure	IP 20 (IP 21*)/Chassis(Type 1)		A2					A3	
	IP 55 + IP 66 /Type 12		A4 + A5					A5	
			P1K1	P1K5	P2K2	P3K0	P4K0	P5K5	P7K5
Typical Shaft Output		[kW]	1.1	1.5	2.2	3	4	5.5	7.5
Typical Shaft Output at 460 V		[HP]	1.5	2.0	2.9	4.0	5.0	7.5	10
Output Current (3 x 380 – 440 V)	Continuous	[A]	3	4.1	5.6	7.2	10	13	16
	Intermittent	[A]	3.3	4.5	6.2	7.9	11	14.3	17.6
Output Current (3 x 441 – 480 V)	Continuous	[A]	2.7	3.4	4.8	6.3	8.2	11	14.5
	Intermittent	[A]	3.0	3.7	5.3	6.9	9.0	12.1	15.4
Output Power (400 V AC)	Continuous	[kVA]	2.1	2.8	3.9	5.0	6.9	9.0	11.0
Output Power (460 V AC)	Continuous	[kVA]	2.4	2.7	3.8	5.0	6.5	8.8	11.6
Max. cable size (Mains, motor, brake)		[mm ²] ([AWG])	4 (10)						
Max. Input Current (3 x 380 – 440 V)	Continuous	[A]	2.7	3.7	5.0	6.5	9.0	11.7	14.4
	Intermittent	[A]	3.0	4.1	5.5	7.2	9.9	12.9	15.8
Max. Input Current (3 x 441 – 480 V)	Continuous	[A]	2.7	3.1	4.3	5.7	7.4	9.9	13.0
	Intermittent	[A]	3.0	3.4	4.7	6.3	8.1	10.9	14.3
Max. pre-fuses		[A]	10	10	20	20	20	32	32
Environment									
Estimated power loss at rated max. load		[W]	58	62	88	116	124	187	255
Weight									
IP 20		[kg]	4.8	4.9	4.9	4.9	4.9	6.6	6.6
IP 55, IP 66		[kg]	13.5	13.5	13.5	13.5	13.5	14.2	14.2
Efficiency			0.96	0.97	0.97	0.97	0.97	0.97	0.97

Enclosure	IP 20 (IP 21*)/Chassis(Type 1)		B3			B4			C3		C4	
	IP 21/Type 1, IP 55 + IP 66/Type 12		B1			B2			C1		C2	
			P11K	P15K	P18K	P22K	P30K	P37K	P45K	P55K	P75K	P90K
Typical Shaft Output		[kW]	11	15	18.5	22	30	37	45	55	75	90
Typical Shaft Output at 460 V		[HP]	15	20	25	30	40	50	60	75	100	125
Output Current (3 x 380 – 439 V)	Continuous	[A]	24	32	37.5	44	61	73	90	106	147	177
	Intermittent	[A]	26.4	35.2	41.3	48.4	67.1	80.3	99	117	162	195
Output Current (3 x 440 – 480 V)	Continuous	[A]	21	27	34	40	52	65	80	105	130	160
	Intermittent	[A]	23.1	29.7	37.4	44	61.6	71.5	88	116	143	176
Output Power (400 V AC)	Continuous	[kVA]	16.6	22.2	26	30.5	42.3	50.6	62.4	73.4	102	123
Output Power (460 V AC)	Continuous	[kVA]	16.7	21.5	27.1	31.9	41.4	51.8	63.7	83.7	104	128
Max. cable size Mains, motor, brake		[mm ²] ([AWG])	10 (7)			35 (2)			50 (1/0) (B4 = 35 (2))		95 (4/0)	120 (250 MCM) ¹⁾
Max. cable size mains With mains disconnect switch included		[mm ²] ([AWG])	16 (6)						35 (2)		70 (3/0)	185 (kcmil 350)
Max. Input Current (3 x 380 – 439 V)	Continuous	[A]	22	29	34	40	55	66	82	96	133	161
	Intermittent	[A]	24.2	31.9	37.4	44	60.5	72.6	90.2	106	146	177
Max. Input Current (3 x 440 – 480 V)	Continuous	[A]	19	25	31	36	47	59	73	95	118	145
	Intermittent	[A]	20.9	27.5	34.1	39.6	51.7	64.9	80.3	105	130	160
Max. pre-fuses		[A]	63	63	63	63	80	100	125	160	250	250
Environment												
Estimated power loss at rated max. load		[W]	278	392	465	525	698	739	843	1083	1384	1474
Weight												
IP 20		[kg]	12	12	12	23.5	23.5	23.5	35	35	50	50
IP 21, IP 55, IP 66		[kg]	23	23	23	27	27	45	45	45	65	65
Efficiency			0.98	0.98	0.98	0.98	0.98	0.98	0.98	0.98	0.98	0.99

* (A2, A3, B3, B4, C3 and C4 may be converted to IP21 using a conversion kit. Please contact Danfoss.
(Please see also items Mechanical mounting in Operating Instructions and IP 21/ Type 1 Enclosure kit in the Design Guide.))

1) With brake and load sharing 95 (4/0)

525 – 600 VAC

Enclosure																			
IP 20 Chassis		A3				A3				B3			B4			C3		C4	
IP 21/Type 1										B1			B2			C1		C2	
IP 55, IP 66/Type 12		A5																	
		P1K1	P1K5	P2K2	P3K0	P4K0	P5K5	P7K5	P11K	P15K	P18K	P22K	P30K	P37K	P45K	P55K	P75K	P90K	
Typical Shaft Output	[kW]	1.1	1.5	2.2	3	4	5.5	7.5	11	15	18.5	22	30	37	45	55	75	90	
Output Current																			
Continuous (3 x 525 – 550 V)	[A]	2.6	2.9	4.1	5.2	6.4	9.5	11.5	19	23	28	36	43	54	65	87	105	137	
Intermittent (3 x 525 – 550 V)	[A]	2.9	3.2	4.5	5.7	7.0	10.5	12.7	21	25	31	40	47	59	72	96	116	151	
Continuous (3 x 525 – 600 V)	[A]	2.4	2.7	3.9	4.9	6.1	9.0	11.0	18	22	27	34	41	52	62	83	100	131	
Intermittent (3 x 525 – 600 V)	[A]	2.6	3.0	4.3	5.4	6.7	9.9	12.1	20	24	30	37	45	57	68	91	110	144	
Output Power																			
Continuous (525 V AC)	[kVA]	2.5	2.8	3.9	5.0	6.1	9.0	11.0	18.1	21.9	26.7	34.3	41	51.4	61.9	82.9	100	130.5	
Continuous (575 V AC)	[kVA]	2.4	2.7	3.9	4.9	6.1	9.0	11.0	17.9	21.9	26.9	33.9	40.8	51.8	61.7	82.7	99.6	130.5	
Max. cable size IP 20 (mains, motor, brake)	[mm ²] ([AWG])	4 (10)								10 (7)			35 (2)			50 (1/0)		95 (4/0)	120 (250 MCM)
Max. cable size IP 21/55/66 (mains, motor, brake)	[mm ²] ([AWG])	4 (10)								10 (7)			35 (2)			50 (1/0)		95 (4/0)	150 (250 MCM) ¹⁾
Max. cable size mains With mains disconnect switch included	[mm ²] ([AWG])	4 (10)								16 (6)			35 (2)			70 (3/0)		185 (kcmil 350)	
Max. Input Current																			
Continuous (3 x 525 – 600 V)	[A]	2.4	2.7	4.1	5.2	5.8	8.6	10.4	17.2	20.9	25.4	32.7	39	49	59	78.9	95.3	124.3	
Intermittent (3 x 525 – 600 V)	[A]	2.7	3.0	4.5	5.7	6.4	9.5	11.5	19	23	28	36	43	54	65	87	105	137	
Max. pre-fuses	[A]	10	10	20	20	20	32	32	63	63	63	63	80	100	125	160	250	250	
Environment																			
Estimated power loss at rated max. load	[W]	50	65	92	122	145	195	261	300	400	475	525	700	750	850	1100	1400	1500	
Weight																			
IP 20	[kg]	6.5	6.5	6.5	6.5	6.5	6.6	6.6	12	12	12	23.5	23.5	23.5	35	35	50	50	
IP 21, IP 55, IP 66	[kg]	13.5	13.5	13.5	13.5	13.5	14.2	14.2	23	23	23	27	27	27	45	45	65	65	
Efficiency		0.97	0.97	0.97	0.97	0.97	0.97	0.97	0.98	0.98	0.98	0.98	0.98	0.98	0.98	0.98	0.98	0.98	

1) With brake and load sharing 95 (4/0)

380 – 480 VAC and 525 – 690 VAC

High Power

380 – 480 VAC

Enclosure	IP 21/Type 1, IP 54/Type 12		D1		D2		
	IP 00/Chassis		D3		D4		
			P110	P132	P160	P200	P250
Typical Shaft Output at 400 V	[kW]		110	132	160	200	250
Typical Shaft Output at 460 V	[HP]		150	200	250	300	350
Output Current							
Continuous (at 400 V)	[A]		212	260	315	395	480
Intermittent (60 sec overload) (at 400 V)	[A]		233	286	347	435	528
Continuous (at 460/480 V)	[A]		190	240	302	361	443
Intermittent (60 sec overload) (at 460/480 V)	[A]		209	264	332	397	487
Output Power							
Continuous (at 400 V)	[kVA]		147	180	218	274	333
Continuous (at 460 V)	[kVA]		151	191	241	288	353
Max. Input Current							
Continuous (at 400 V)	[A]		204	251	304	381	463
Continuous (at 460/480 V)	[A]		183	231	291	348	427
Max. cable size Mains motor, brake and load share	[mm ²] ([AWG])		2 x 70 (2 x 2/0)		2 x 150 (2 x 300 mcm)		
Max. external pre-fuses	[A]		300	350	400	500	630
Estimated power loss at rated max. load – 400 V	[W]		3234	3782	4213	5119	5893
Estimated power loss at rated max. load – 460 V	[W]		2947	3665	4063	4652	5634
Weight	IP 21, IP 54	[kg]	96	104	125	136	151
	IP 00	[kg]	82	91	112	123	138
Efficiency			0.98				
Output Frequency	[Hz]		0 – 800				
Heatsink over-temperature trip	[°C]		85	90	105	105	115
Power card ambient trip	[°C]		60				

525 – 690 VAC

Enclosure	IP 21/Type 1, IP 54/Type 12		D1						D2		
	IP 00/Chassis		D3						D4		
			P45K	P55K	P75K	P90K	P110	P132	P160	P200	P250
Typical Shaft Output at 550 V	[kW]		37	45	55	75	90	110	132	160	200
Typical Shaft Output at 575 V	[HP]		50	60	75	100	125	150	200	250	300
Typical Shaft Output at 690 V	[kW]		45	55	75	90	110	132	160	200	250
Output Current											
Continuous (at 3 x 525 – 550 V)	[A]		56	76	90	113	137				
Continuous (at 550 V)	[A]							162	201	253	303
Intermittent (60 sec overload) (at 550 V)	[A]		62	84	99	124	151	178	221	278	333
Continuous (at 3 x 551 – 690 V)	[A]		54	73	86	108	131				
Continuous (at 575/690 V)	[A]							155	192	242	290
Intermittent (60 sec overload) (at 575/690 V)	[A]		59	80	95	119	144	171	211	266	319
Output Power											
Continuous (at 550 V)	[kVA]		53	72	86	108	131	154	191	241	289
Continuous (at 575 V)	[kVA]		54	73	86	108	130	154	191	241	289
Continuous (at 690 V)	[kVA]		65	87	103	129	157	185	229	289	347
Max. Input Current											
Continuous (at 550 V)	[A]		60	77	89	110	130	158	198	245	299
Continuous (at 575 V)	[A]		58	74	85	106	124	151	189	234	286
Continuous (at 690 V)	[A]		58	77	87	109	128	155	197	240	296
Max. cable size Mains, motor, load share and brake	[mm ²] ([AWG])		2 x 70 (2 x 2/0)				2 x 70 (2 x 2/0)		2 x 150 (2 x 300 mcm)		
Max. external pre-fuses	[A]		125	160	200	200	250	315	350	350	400
Estimated power loss at rated max. load – 600 V	[W]		1398	1645	1827	2157	2533	2963	3430	4051	4867
Estimated power loss at rated max. load – 690 V	[W]		1458	1717	1913	2262	2662	3430	3612	4292	5156
Weight	IP 21, IP 54	[kg]	96						104	125	136
	IP 00	[kg]	82						91	112	123
Efficiency			0.97			0.98					
Output Frequency	[Hz]		0 – 600								
Heatsink over-temperature trip	[°C]		85					90	110		
Power card ambient trip	[°C]		60								

Dimensions VLT® HVAC Drive

In mm

A2 enclosures

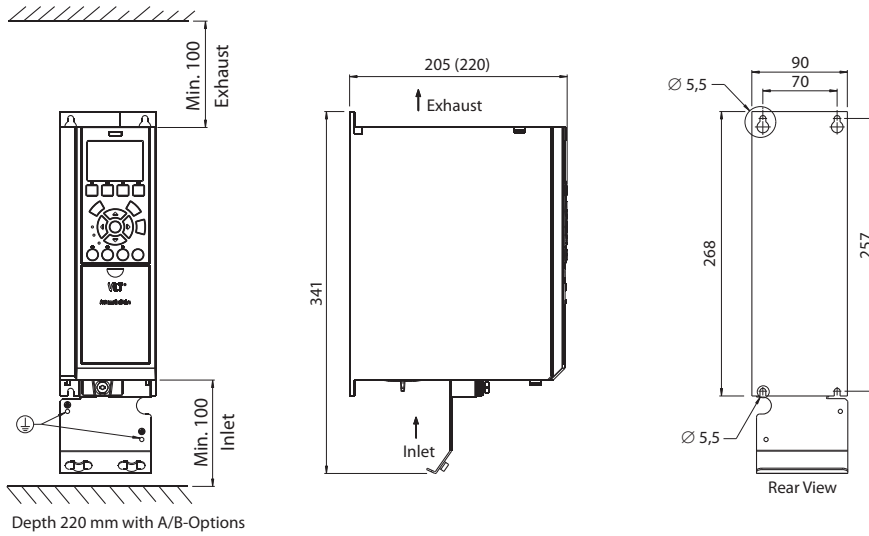

A2

A3 enclosures

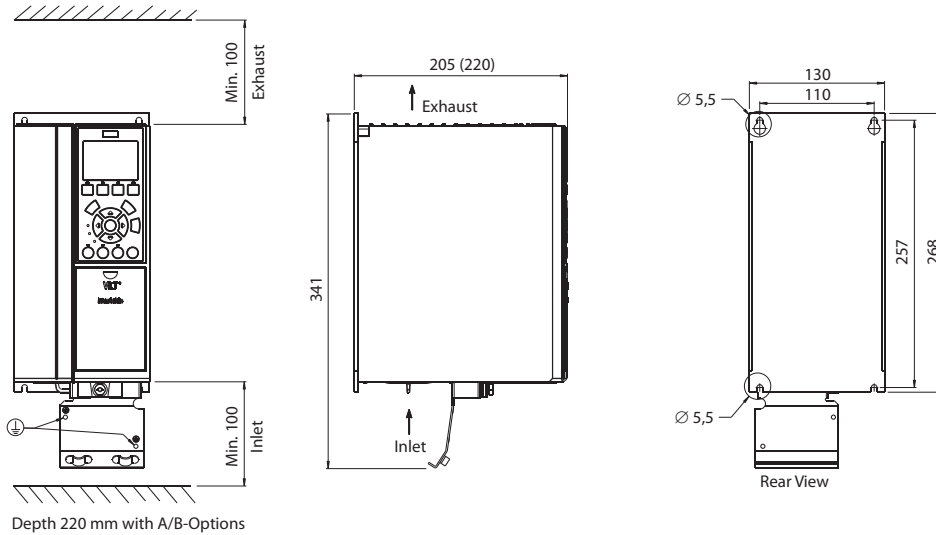

A3

A4 enclosures

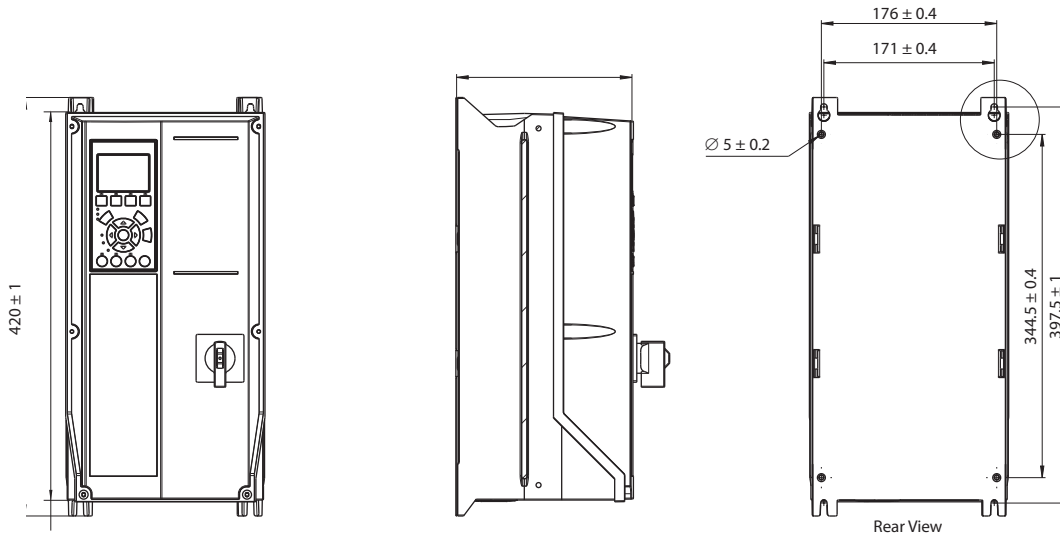

A4

Dimensions VLT® HVAC Drive

In mm

A5 enclosures

A5

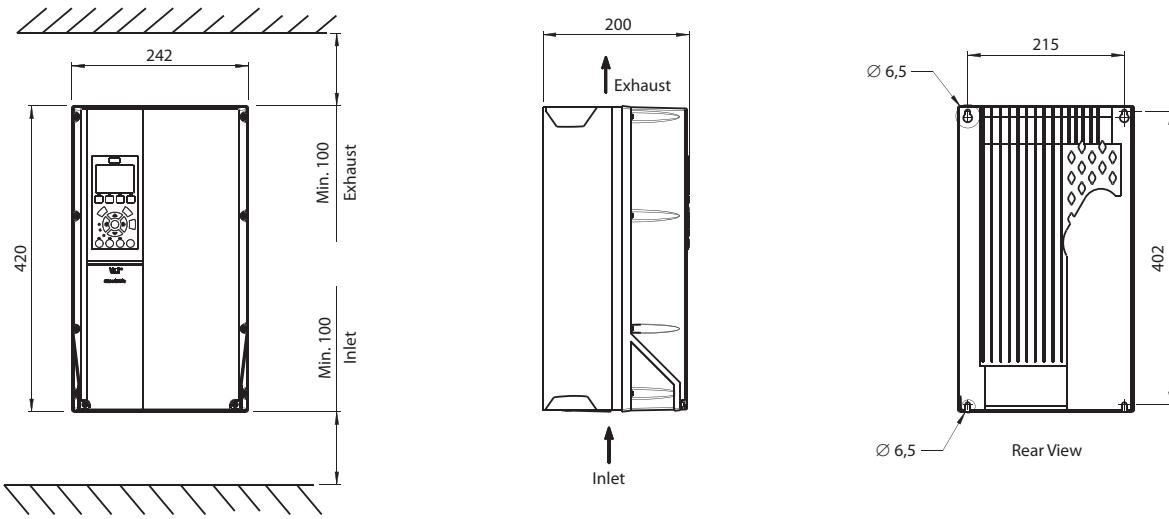

B1 enclosures

B1

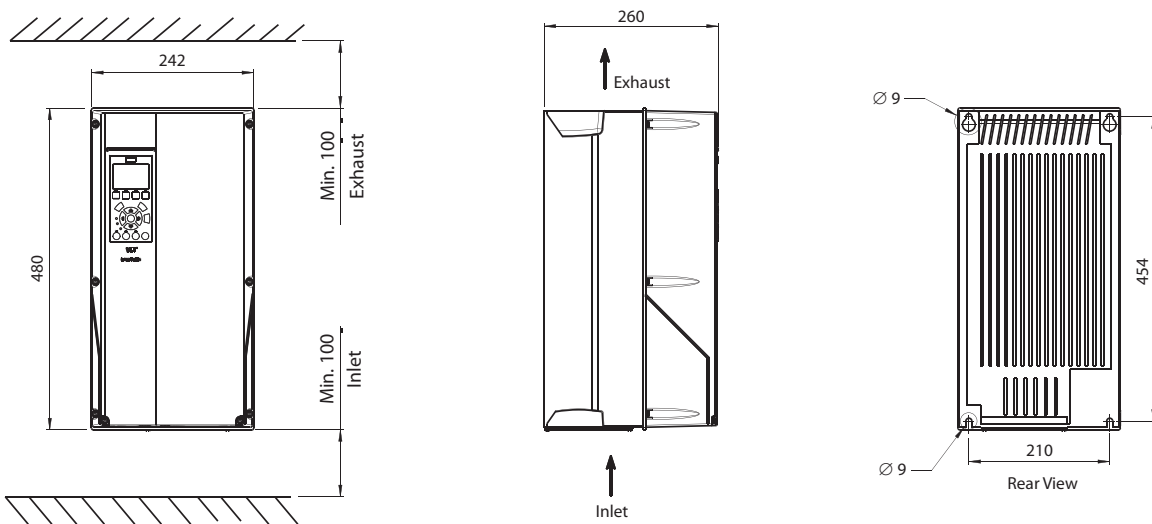

B2 enclosures

B2

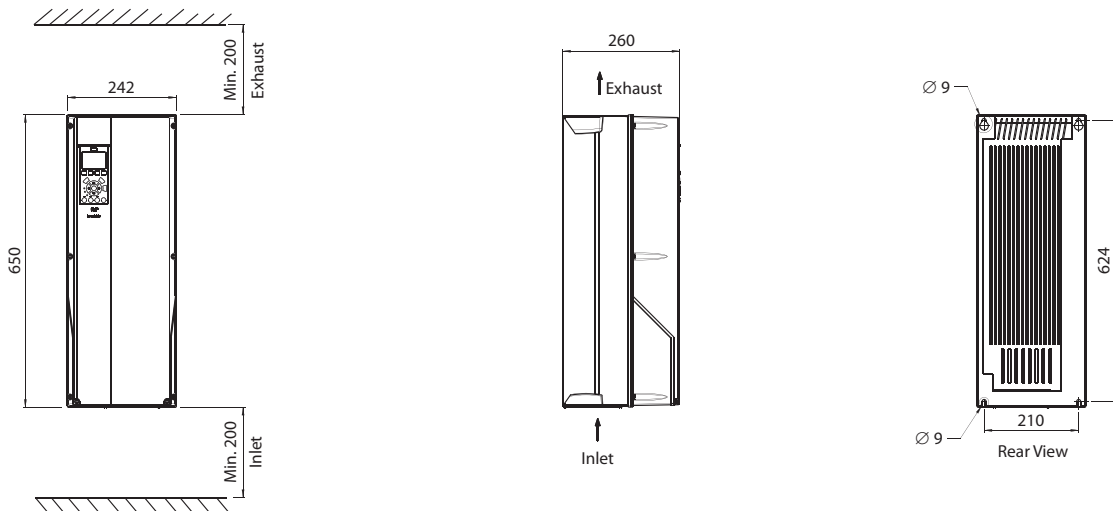

B3 enclosures

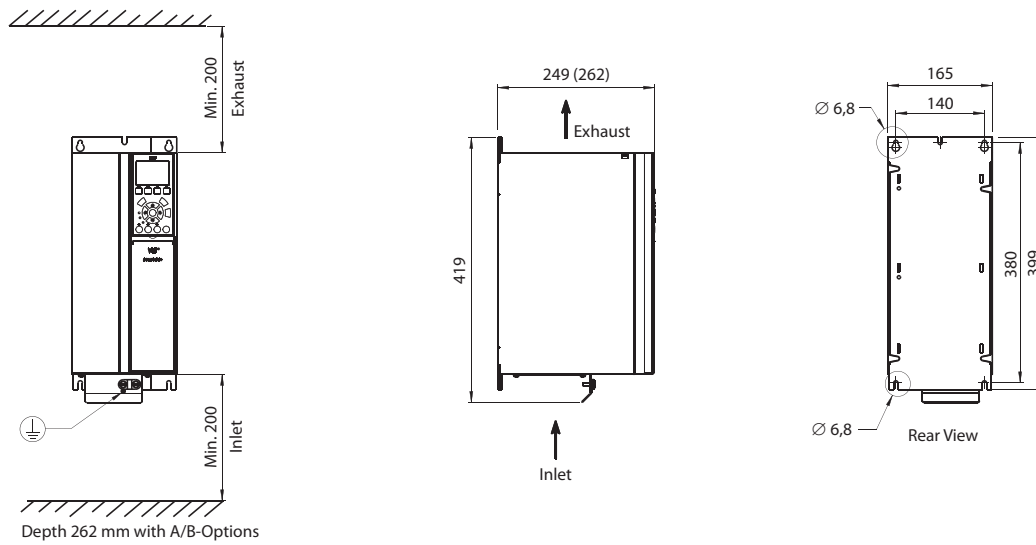

B3

B4 enclosures

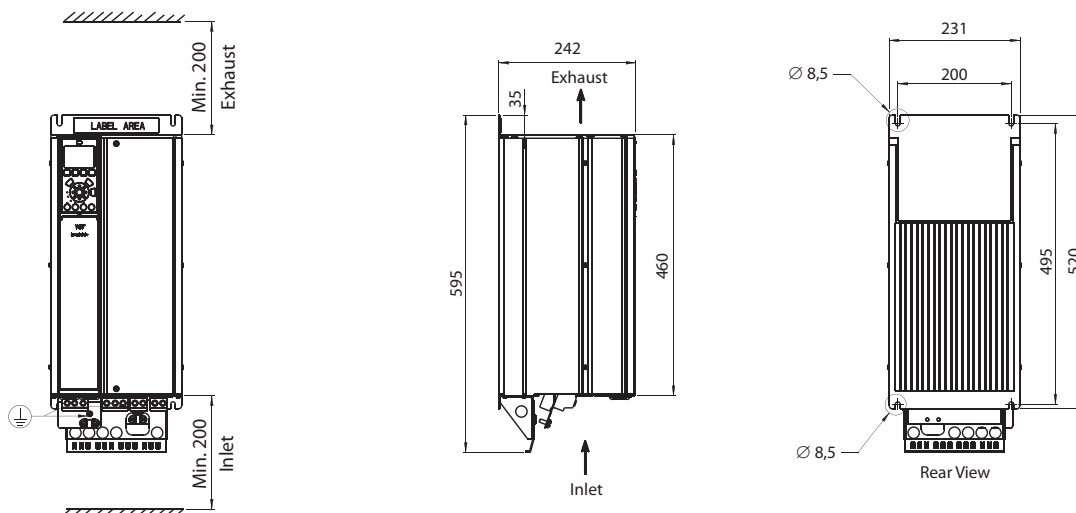

B4

C1 enclosures

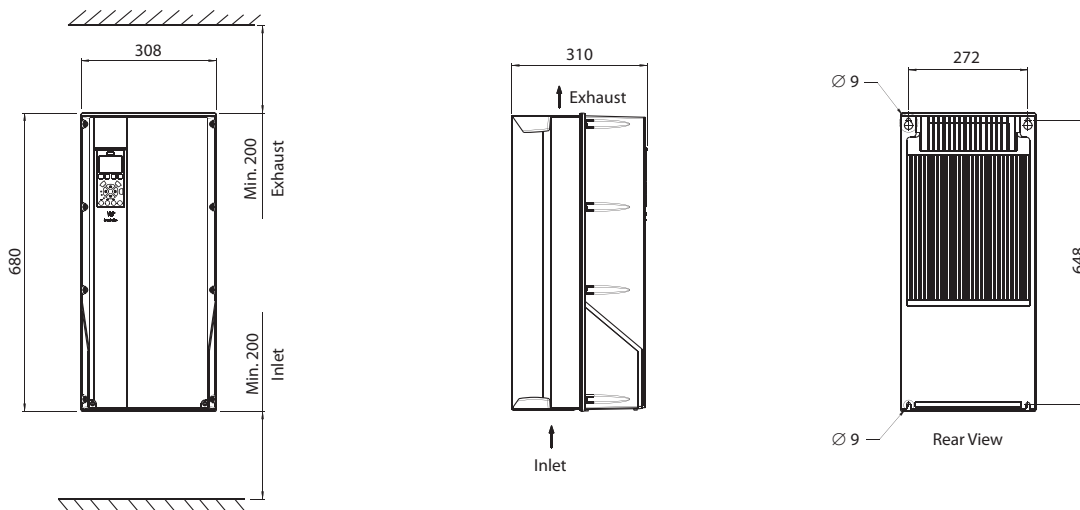

C1

Dimensions VLT® HVAC Drive

In mm

C2 enclosures

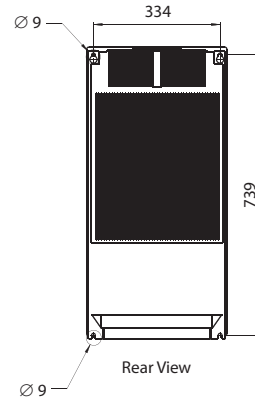
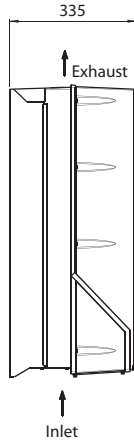
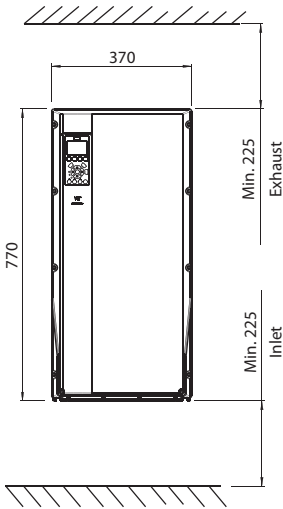

C3 enclosures

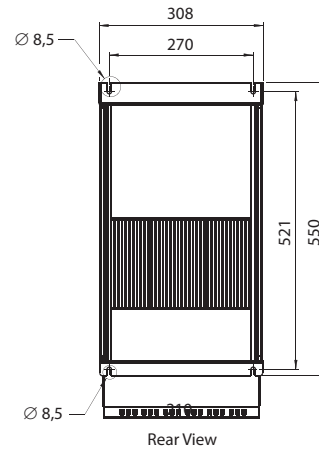
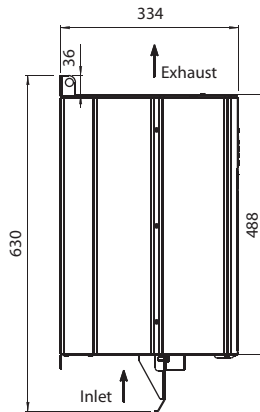
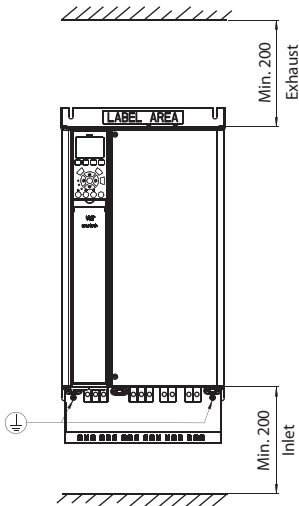

C4 enclosures

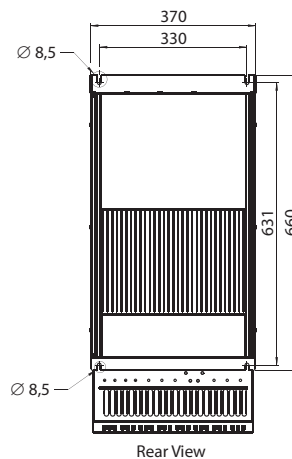
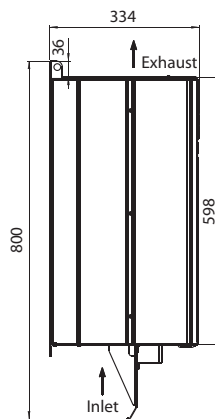
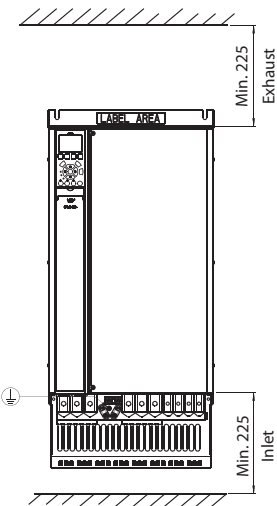

D1 enclosures (floor- or cabinet mount)

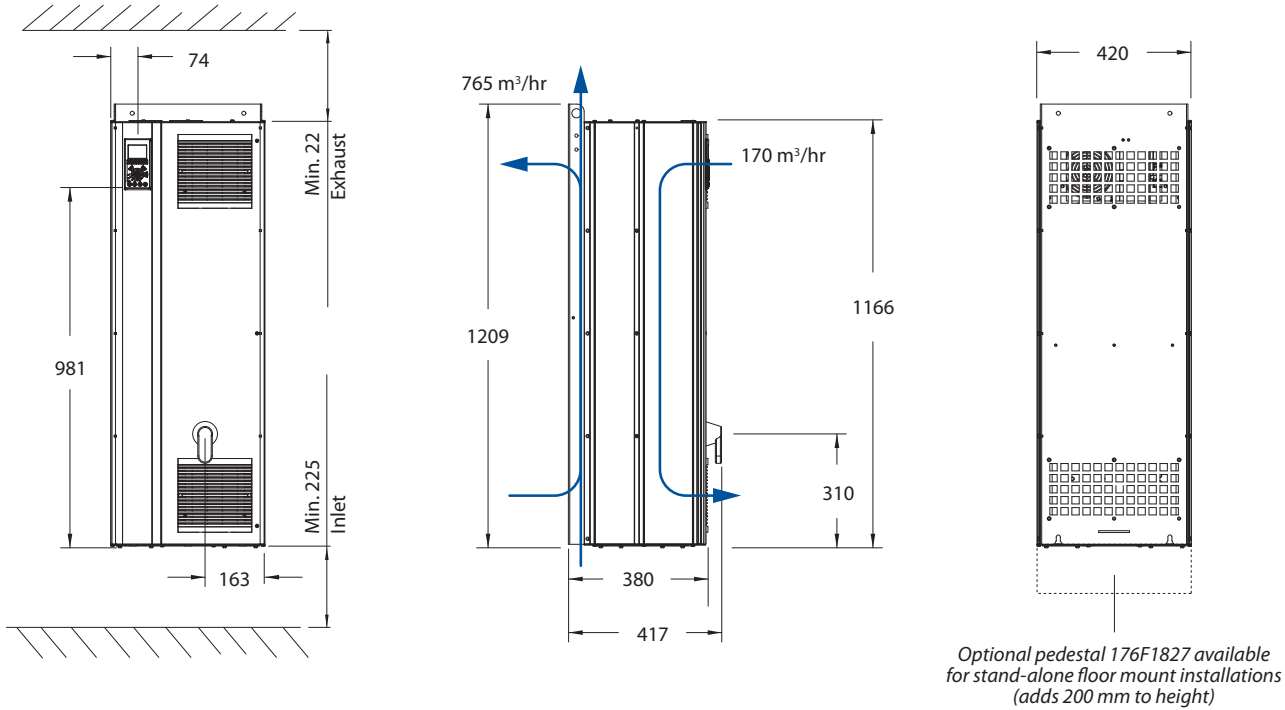

D1

D2 enclosures (floor- or cabinet mount)

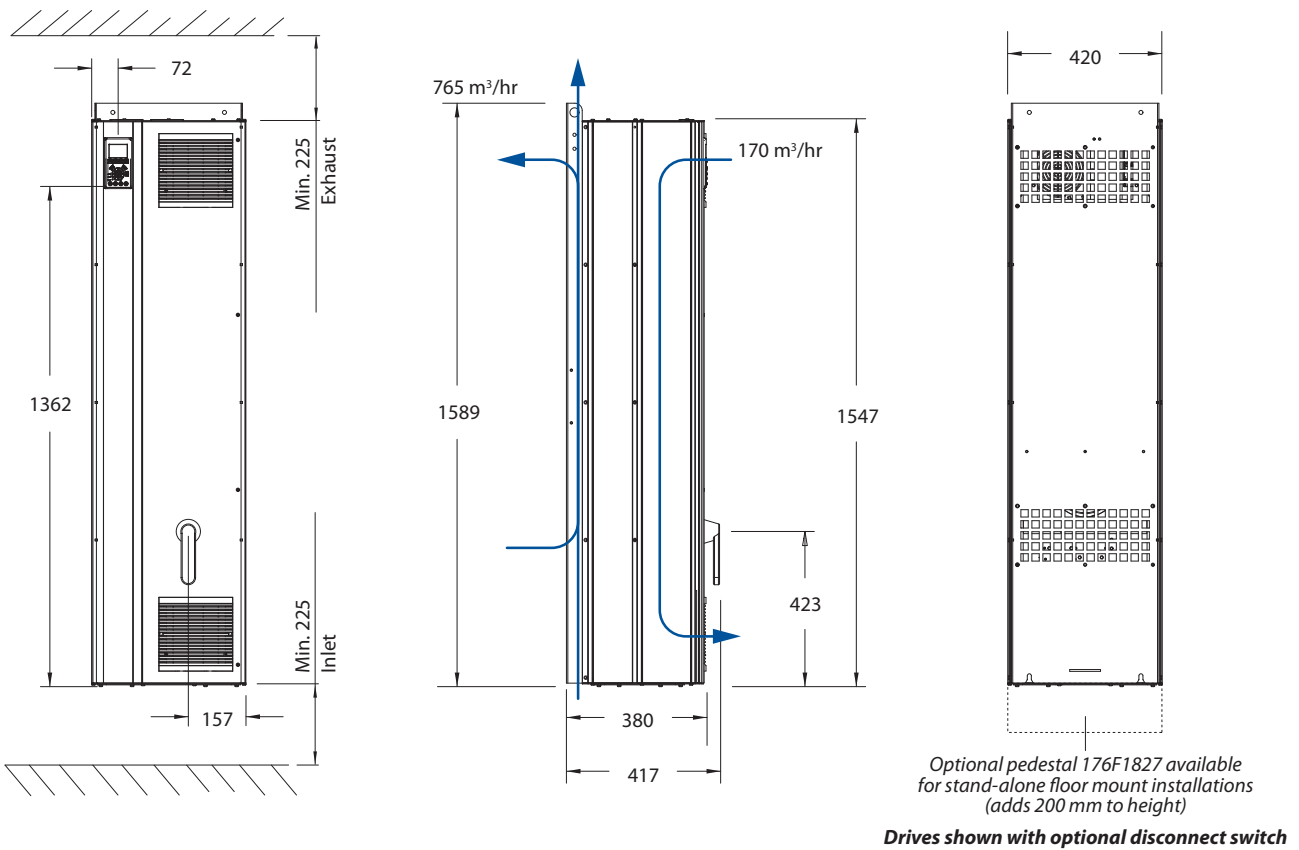

D2

Dimensions VLT® HVAC Drive

In mm

D3 enclosures (cabinet mount)

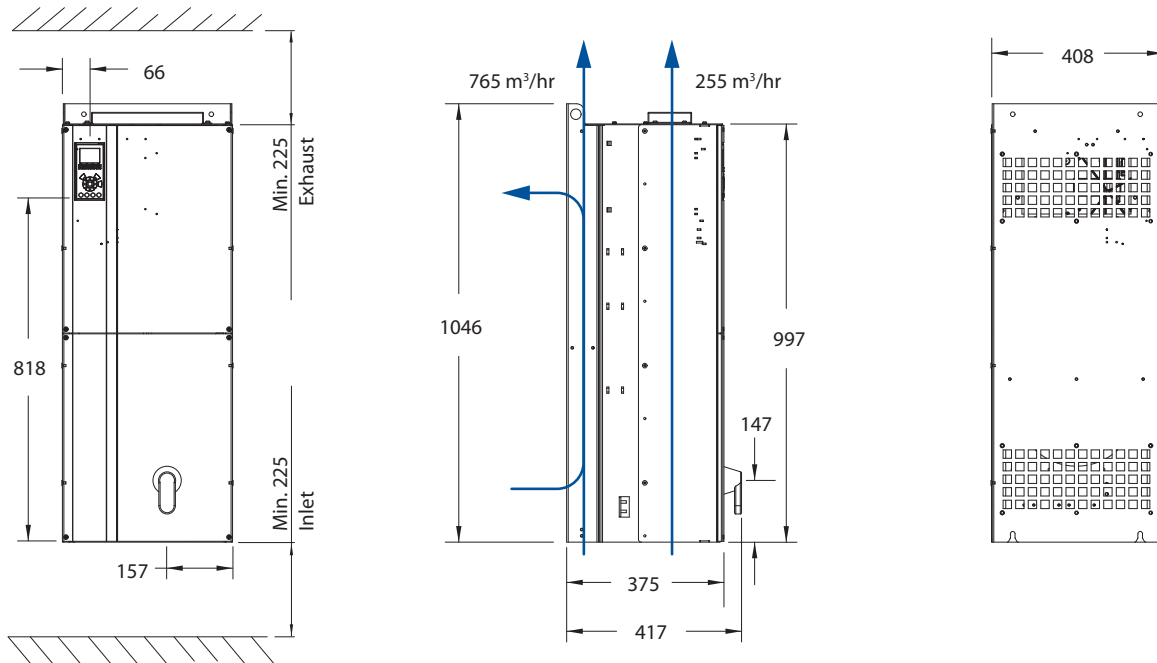

D4 enclosures (cabinet mount)

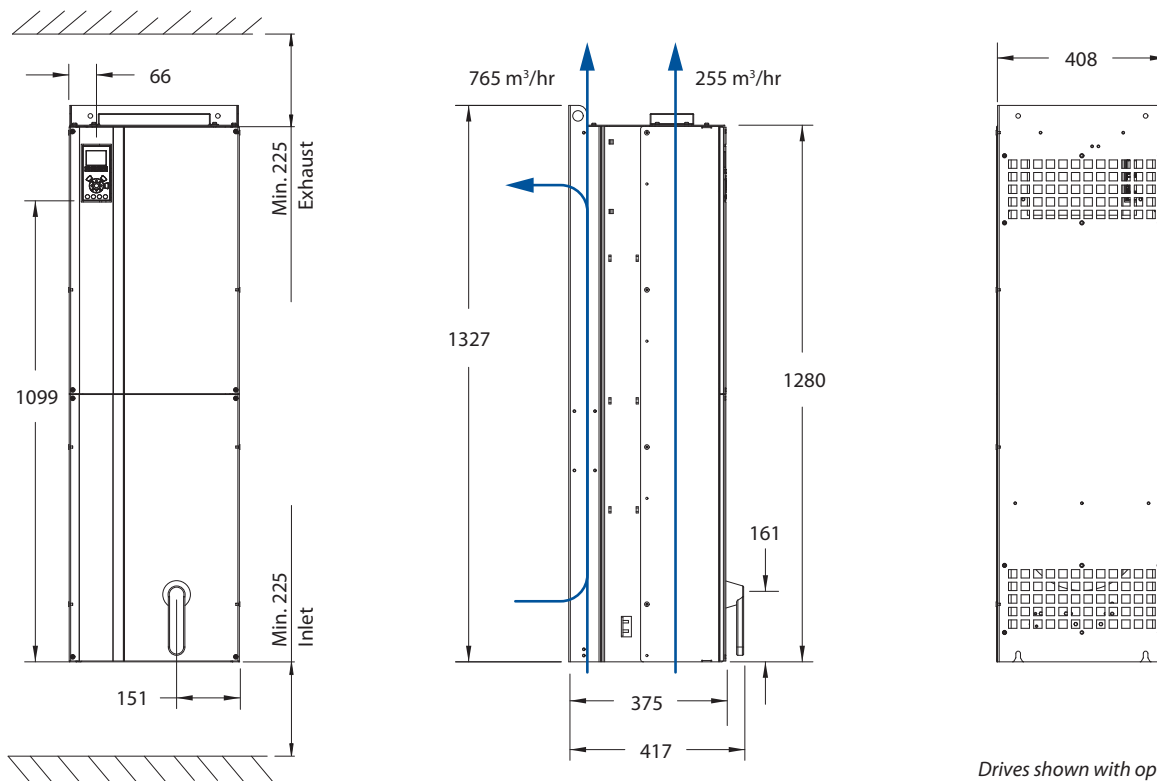

Drives shown with optional disconnect switch

D3

D4

VLT® HVAC Drive A Options

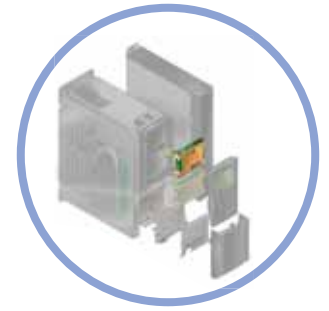

Typecode Position



VLT® LonWorks MCA 108

LonWorks is a fieldbus system developed for building automation. It enables communication between individual units in the same system (peer-to-peer) and thus supports decentralization of control.

- No need for a big main station (master-follower)
- Units receive signals directly
- Supports Echelon free-topology interface (flexible cabling and installation)

- Supports embedded I/Os and I/O options (easy implementation of de-central I/Os)
- Sensor signals can quickly be moved to another controller via bus cables
- Certified as compliant with LonMark ver. 3.4 specifications

Ordering number 130B1106 uncoated – 130B1206 coated (Class 3C3/IEC 60721-3-3)

13



VLT® BACnet MCA 109

The open communications protocol for worldwide building automation use. The BACnet protocol is an international protocol that efficiently integrates all parts of building automation equipment from the actuator level to the building management system.

- BACnet is the world standard for building automation
- International standard ISO 16484-5
- With no license fees, the protocol can be used in building automation systems of all sizes

- The BACnet option lets the drive communicate with building management systems running the BACnet protocol
- Typical areas where BACnet is used include heating, ventilation, cooling and climate equipment control
- The BACnet protocol is easily integrated into existing control equipment networks

Ordering number 130B11446 uncoated – 130B1244 coated (Class 3C3/IEC 60721-3-3)

13



VLT® DeviceNet MCA 104

- This modern communications model offers key capabilities that let you effectively determine what information is needed and when
- You will also benefit from ODVA's strong conformance testing policies, which ensure that products are interoperable

Ordering number 130B1102 uncoated – 130B1202 coated (Class 3C3/IEC 60721-3-3)

13



VLT® PROFIBUS DP V1 MCA 101

- PROFIBUS DP V1 gives you wide compatibility, a high level of availability, support for all major PLC vendors, and compatibility with future versions
- Fast, efficient communication, transparent installation, advanced diagnosis and parameterisation and auto-configuration of process data via GSD-file
- A-cyclic parameterisation using PROFIBUS DP V1, PROFIdrive or Danfoss FC profile state machines, PROFIBUS DP V1, Master Class 1 and 2

Ordering number 130B1100 uncoated – 130B1200 coated (Class 3C3/IEC 60721-3-3)

13

Installation of options is a simple matter of plug-and-play

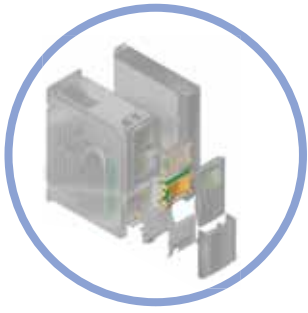

VLT® HVAC Drive B Options

Typecode Position

14



VLT® General Purpose I/O MCB 101

The I/O option offers an extended number of control inputs and outputs.

- 3 digital inputs 0-24 V:
Logic '0' < 5 V; Logic '1' > 10 V
- 2 analogue inputs 0-10 V:
Resolution 10 bit plus sign
- 2 digital outputs NPN/PNP push pull

- 1 analogue output 0/4-20 mA
- Spring loaded connection
- Separate parameter settings

Ordering number 130B1125 uncoated – 130B1212 coated
(Class 3C3/IEC 60721-3-3)

14



VLT® Relay Option MCB 105

Lets you extend relay functions with 3 additional relay outputs.

Max. terminal load:
AC-1 Resistive load240 V AC 2 A
AC-15 Inductive load @cos φ 0.4240 V AC 0.2 A
DC-1 Resistive load24 V DC 1 A
DC-13 Inductive load @cos φ 0.424 V DC 0.1 A

Min. terminal load:
DC 5 V 10 mA
Max switch rate at rated
load/min. load 6 min-1/20 sec-1

Ordering number 130B1110 uncoated – 130B1210 coated
(Class 3C3/IEC 60721-3-3)

14



VLT® Analogue I/O Option MCB 109

This analogue input/output option is easily fitted in the frequency converter for upgrading to advanced performance and control using the additional in/outputs. This option also upgrades the frequency converter with a battery back-up supply for the clock built into the frequency converter. This provides stable use of all frequency converter clock functions as timed actions etc.

- 3 analogue inputs, each configurable as both voltage and temperature input
- Connection of 0-10 V analogue signals as well as PT1000 and NI1000 temperature inputs

- 3 analogue outputs each configurable as 0-10 V outputs
- Incl. back-up supply for the standard clock function in the frequency converter

The back-up battery typically lasts for 10 years, depending on environment.

Ordering number 130B1143 uncoated – 130B1243 coated
(Class 3C3/IEC 60721-3-3)

14



VLT® PTC Thermistor Card MCB 112

With the MCB 112 PTC Thermistor Card, the Danfoss VLT® HVAC Drive FC 102 now offers improved surveillance of the motor condition compared to the built-in ETR function and thermistor terminal.

- Protects the motor from overheating
- ATEX approved for use in potentially explosive atmospheres
- Uses Safe Stop function, which is approved in accordance with Cat. 3 EN954-1

14



VLT® Sensor Input Card MCB 114

The option protects the motor from being overheated by monitoring the bearings and windings temperature in the motor. The limits as well as the action are adjustable and the individual sensor temperature is visible as a read-out in the display or by fieldbus.

- Protects the motor from overheating
- Three self-detecting sensor inputs for 2 or 3 wire PT100/PT1000 sensors
- One additional analogue input 4-20mA

Installation of options is a simple matter of plug-and-play

VLT® HVAC Drive D Options & LCP

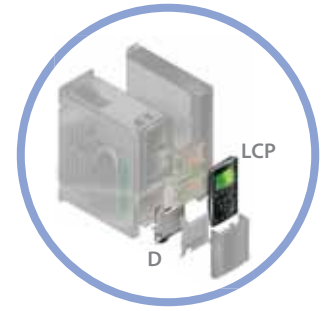

Typecode Position



VLT® 24 V DC Supply Option MCB 107

The option is used to connect an external DC supply to keep the control section and any installed option active when mains power is down.

- Input voltage range..... 24 V DC +/- 15% (max. 37 V in 10 sec.)
- Max. input current2.2 A
- Max. cable length 75 m
- Input capacitance load < 10 uF

- Power-up delay < 0.6 s
- Easy to install in drives in existing machines
- Keeps the control board and options active during power cuts
- Keeps fieldbuses active during power cuts

Ordering number 130B1108 uncoated – 130B1208 coated (Class 3C3/IEC 60721-3-3)

18



Graphical Local Control Panel LCP 102

- Multi-language display
- Status messages
- Quick Menu for easy commissioning
- Parameter setting and explanation of parameter function
- Adjustment of parameters
- Full parameter backup and copy function
- Alarm logging

- Info button – explains the function of the selected item on display
- Hand-operated start/stop, or automatic mode selection
- Reset function
- Trend graph

Ordering number 130B1107

15 + 17



Numerical Local Control Panel LCP 101

The numerical control panel offers an excellent MMI interface to the drive.

- Status messages
- Quick menu for easy commissioning
- Parameter setting and adjustment

- Hand-operated start/stop function or automatic mode select
- Reset function

Ordering number 130B1124

15



LCP Panel Mounting Kit

For easy installation of the LCP 101 and LCP 102 in e.g. a cabinet.

- IP 65/Type 12 (front)
- Thumb screws for tool-free installation
- Incl. 3 metres of cables of industrial quality (also available separately)
- With or without LCP operating unit
- Each time easy to install

Ordering number 130B1113 (Incl. graphical LCP, fasteners, 3 m cable and gasket).

Ordering number 130B1114 (Incl. numerical LCP, fasteners and gasket).

Ordering number 130B1129 (LCP front mounting IP 55/IP 66) – Ordering number 175Z0929 (cable only).

Ordering number 130B1170 (Panel Mounting Kit for all LCP w/o cable).

Ordering number 130B1117 (Mounting kit for all LCP's including fasteners, 3 m cable and gasket).

16

Installation of options is a simple matter of plug-and-play

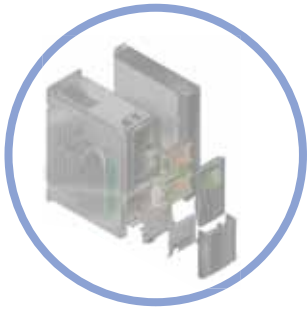

VLT® HVAC Drive Accessories



Profibus Adapter Sub-D9 Connector

The adapter makes linking of fieldbus connections pluggable. For use with option A.

- Option to use prefabricated Profibus cabling
- For retrofit



Screw terminals

Screw terminals as an alternative to the standard springloaded terminals.

- Pluggable
- Terminal name is described

Ordering number 130B1116



IP 21/Type 12 Kit

The IP 21/Type 12 (NEMA1) kit is used for installation of VLT® drives in dry environments. The enclosure kits are available for frame sizes A1, A2, A3, B3, B4, C3 and C4.

- Supports VLT® drives from 1.1 to 90 kW
- Used on standard VLT® drives with or without mounted option modules

- IP 41 on top side
- PG 16 and PG 21 holes for glands

130B1122 for frame size A2, 130B1123 for frame size A3, 130B1187 for frame size B3, 130B1189 for frame size B4, 130B1191 for frame size C3, 130B1193 for frame size C4



Kit for panel through-mount

Mounting kit for external cooling of the heatsink for appliances with A5, B1, B2, C1 and C2 housing.

- The air conditioned installation space can be reduced.

- Additional cooling may be omitted
- No contamination of electronics by forced ventilation
- Facilitates integrated assembly
- Reduced cabinet depth/less space



VLT® Brake Resistors

Energy generated during braking is absorbed by the resistors, protecting electrical components from heating up.

Danfoss brake resistors cover the full power range.

- Quick braking of heavy loads
- Braking energy is only absorbed into the brake resistor
- External mounting makes it possible to use the generated heat
- All necessary approvals are available



USB Extension

USB extension for IP 55 and IP 66 enclosures. Makes the USB connector available outside the drive. The USB extension is designed for mounting in a cable gland in the bottom of the drive, which makes PC communication very easy, even in drives with high IP ratings.

USB extension for A5-B1 enclosures, 350 mm cable, ordering number 130B1155
 USB extension for B2-C enclosures, 650 mm cable, ordering number 130B1156

Please refer to the product and design manuals for selection and dimensioning

Phone: 800.894.0412 - Fax: 888.723.4773 - Web: www.ctiautomation.net - Email: info@ctiautomation.net

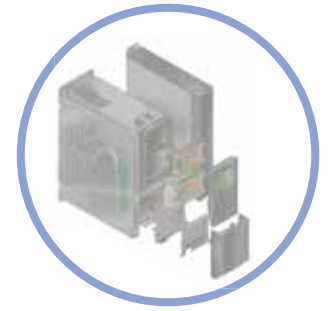

VLT® Harmonic Filter AHF 005/010

Easy, effective harmonic distortion reduction by connecting the AHF 005/010 harmonic filter in front of a Danfoss frequency converter.

- AHF 005 reduces total harmonic current distortion to 5%
- AHF 010 reduces total harmonic current distortion to 10%

- Small compact housing that can be fitted into a panel
- Easy to use in retrofit applications
- User-friendly start-up – no adjustment necessary
- No routine maintenance required



VLT® Sine-Wave Filters

Sine-wave filters are placed between the frequency converter and the motor to optimise the motor power current.

It provides a sinusoidal phase-to-phase motor voltage. The filters reduce motor insulation stress, acoustic noise from the motor, and bearing currents (especially in large motors).

- Reduces motor insulation stress
- Reduces acoustic noise from the motor
- Reduces bearing currents (especially in large motors)
- Enables use of longer motor cables
- Reduces losses in the motor
- Prolongs service lifetime
- IP 20/Chassis; IP 21/Type 1



VLT® dU/dt filter

VLT® dU/dt filters are placed between the frequency converter and the motor to eliminate very fast voltage changes.

The motor terminal phase-to-phase voltage is still pulse shaped but its dU/dt values are reduced.

- These filters reduce stress on the motor's insulation and are recommended in applications with older motors, aggressive environments or frequent braking which cause increased DC link voltage.
- IP 20/Chassis; IP21/Type 1



SVCD – regenerative braking

Transferring the generated power from a decelerating motor back into the power supply enables braking of virtually unlimited duration.

- Energy efficient braking
- Self-synchronisation

- DC-DC coupling of multiple drives possible
- High efficiency through IGBT technology
- Simple operation
- Overload protection in regenerative operation

What VLT[®] is all about

Danfoss VLT Drives is the world leader among dedicated drives providers – and still gaining market share.

Environmentally responsible

VLT[®] products are manufactured with respect for the safety and well-being of people and the environment.

All activities are planned and performed taking into account the individual employee, the work environment and the external environment. Production takes place with a minimum of noise, smoke or other pollution and environmentally safe disposal of the products is pre-prepared.

UN Global Compact

Danfoss has signed the UN Global Compact on social and environmental responsibility and our companies act responsibly towards local societies.

EU Directives

All factories are certified according to ISO 14001 standard. All products fulfil the EU Directives for General Product Safety and the Machinery directive. Danfoss VLT Drives is, in all product series, implementing the EU Directive concerning Hazardous Substances in Electrical and Electrical Equipment (RoHS) and is designing all new product series according to the EU Directive on Waste Electrical and Electronic Equipment (WEEE).

Impact on energy savings

One year's energy savings from our annual production of VLT[®] drives will save the energy equivalent to the energy production from a major power plant. Better process control at the same time improves product quality and reduces waste and wear on equipment.

Dedicated to drives

Dedication has been a key word since 1968, when Danfoss introduced the world's first mass produced variable speed drive for AC motors – and named it VLT[®].

Twenty five hundred employees develop, manufacture, sell and service drives and soft starters in more than one hundred countries, focused only on drives and soft starters.

Intelligent and innovative

Developers at Danfoss VLT Drives have fully adopted modular principles in development as well as design, production and configuration.

Tomorrow's features are developed in parallel using dedicated technology platforms. This allows the development of all elements to take place in parallel, at the same time reducing time to market and ensuring that customers always enjoy the benefits of the latest features.

Rely on the experts

We take responsibility for every element of our products. The fact that we develop and produce our own features, hardware, software, power modules, printed circuit boards, and accessories is your guarantee of reliable products.

Local backup – globally

VLT[®] motor controllers are operating in applications all over the world and Danfoss VLT Drives' experts located in more than 100 countries are ready to support our customers with application advice and service wherever they may be.

Danfoss VLT Drives experts don't stop until the customer's drive challenges are solved.

