

Electronic overload relay EF19 and EF45

Electronic overload relays offer reliable protection in case of overload and phase-failure. They are the alternative to thermal overload relays. Motor starters are combinations of overload relays and contactors.

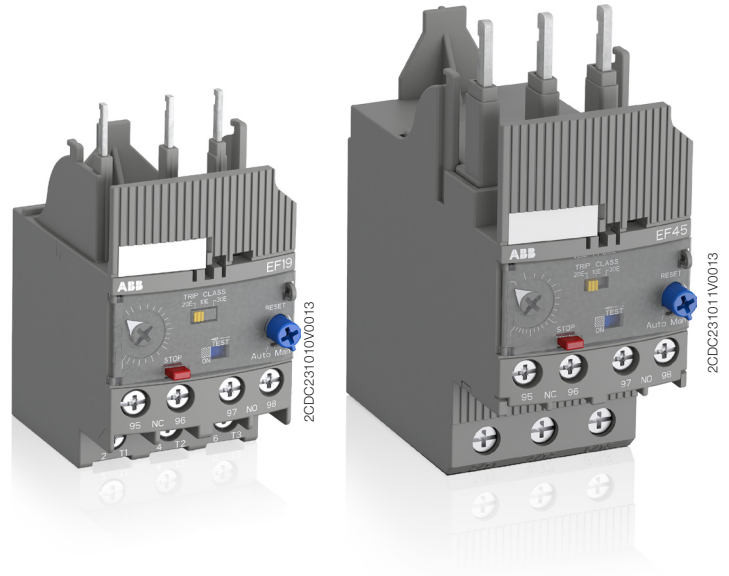

Description

- Overload protection – trip class 10E, 20E, 30E selectable
- Phase loss sensitivity
- Temperature compensation from -25 ... +70 °C
- Adjustable current setting for overload protection
- Automatic or manual reset selectable
- Trip-free mechanism
- Status indication
- STOP and TEST function
- Direct mounting onto block contactors
- Sealable operating elements
- Self-supplied devices

Order data

EF19, EF45 screw terminal
For AF09 ... AF38 block contactors



Setting range	Type	Order code	Suitable for	Packing unit	Weight per PCE
A				PCE	kg
0.10 ... 0.32	EF19-0.32	1SAX121001R1101	AF09 ... AF38	1	0.158
0.30 ... 1.00	EF19-1.0	1SAX121001R1102	AF09 ... AF38	1	0.158
0.80 ... 2.70	EF19-2.7	1SAX121001R1103	AF09 ... AF38	1	0.158
1.90 ... 6.30	EF19-6.3	1SAX121001R1104	AF09 ... AF38	1	0.158
5.70 ... 18.9	EF19-18.9	1SAX121001R1105	AF09 ... AF38	1	0.158
9.00 ... 30.0	EF45-30	1SAX221001R1101	AF26 ... AF38	1	0.362
15.0 ... 45.0	EF45-45	1SAX221001R1102	AF26 ... AF38	1	0.362

Accessories	Type	Order code	Suitable for	Packing unit	Weight per PCE
				PCE	kg
Single	DB19EF	1SAX101910R1001	EF19	1	0.046
mounting kit	DB45EF	1SAX201910R0001	EF45	1	0.100

Suitable for mounting on:

AF09, AF12, AF16
AF26, AF30, AF38

Functional description

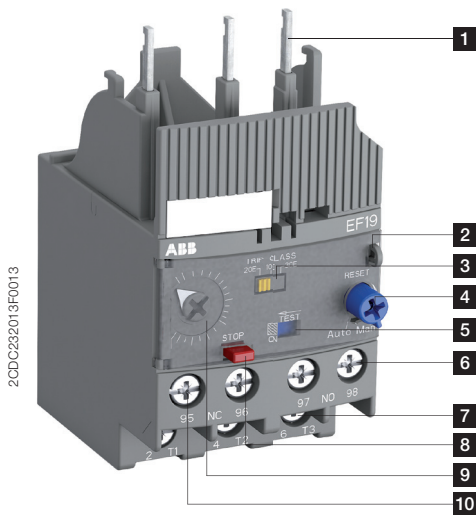

- 1 Terminals 1L1, 3L2, 5L3
- 2 Sealable operating elements
- 3 Trip class 10E, 20E, 30E selectable
- 4 RESET - Automatic or manual reset selectable
- 5 TEST - Status indication
- 6 Signaling contacts 97-98
- 7 Terminals 2T1, 4T2, 6T3
- 8 STOP
- 9 Current setting range / Self-test function ST
Adjustable current setting for overload protection
- 10 Tripping contacts 95-96

Application / internal function

The self-supplied electronic overload relays are three pole electronic/mechanical devices. The motor current flows through build-in current transformers and an evaluation circuit will recognize an overload (over current). This will lead to a release of the relay and a change of the contacts switching position (95-96 / 97-98). The contact 95-96 is used to control the load contactor. The electronic overload relay is self-supplied, which mean no extra external supply is needed.

The overload relays have a setting scale in Amperes, which allows the direct adjusting of the relay without any additional calculation. In compliance with international and national standards, the setting current is the rated current of the motor and not the tripping current (no tripping at $1.05 \times I$, tripping at $1.2 \times I$; I = setting current). The relays are constructed in a way that they protect themselves in the event of an overload. The overload relay has to be protected against short-circuit. The appropriate short-circuit protective devices are shown in the following tables.

To prevent thermal overloads in heavy duty applications, the correct cable sizes have to be selected.

Operation mode

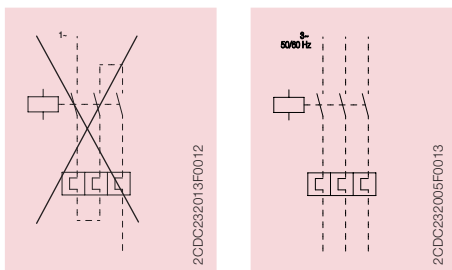

	Contact 95-96	Contact 97-98	Opto-mechanical slide	Comment
Trip state	open	closed		
RESET state	closed	open	ON	
TEST manual reset mode	open	closed		
TEST auto reset mode	open	closed		
STOP while device is in trip state	open	closed		STOP button has no function
STOP while device is in RESET state	open	open		while STOP button is pressed

Wiring diagram

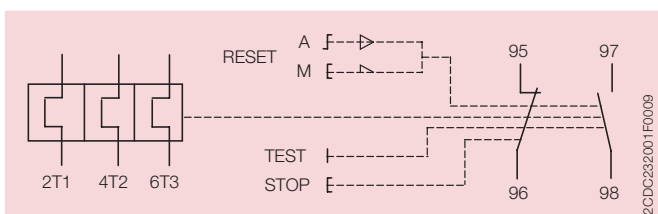

Resistance and power loss per pole and short-circuit protective devices

Type	Setting range		Resistance per pole mΩ	Power loss per pole		Short-circuit protective devices coordination type 2
	lower value A	upper value A		at lower value W	at upper value W	
EF19-0.32	0.1	0.32	447	0.004	0.046	Fuse 1 A, Type gG
EF19-1.0	0.3	1	54	0.005	0.054	Fuse 4 A, Type gG
EF19-2.7	0.8	2.7	7.9	0.005	0.058	Fuse 10 A, Type gG
EF19-6.3	1.9	6.3	2.1	0.008	0.083	Fuse 20 A, Type gG
EF19-18.9	5.7	18.9	0.85	0.028	0.304	Fuse 50 A, Type gG
EF45-30	9	30	0.26	0.021	0.234	Fuse 160 A, Type gG
EF45-45	15	45	0.26	0.059	0.527	Fuse 160 A, Type gG

Intermittent periodic duty

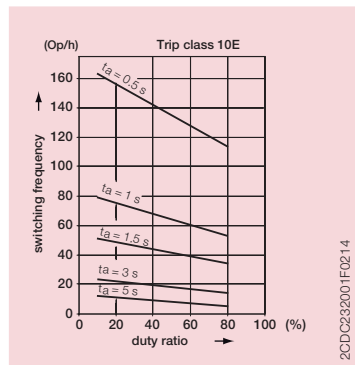

Trip class 10E

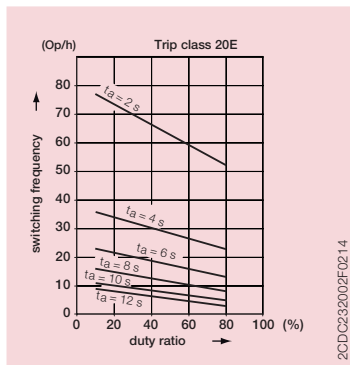

Trip class 20E

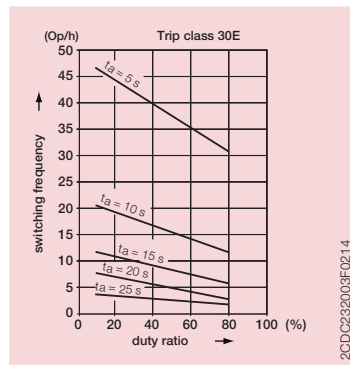

Trip class 30E

Dimensions

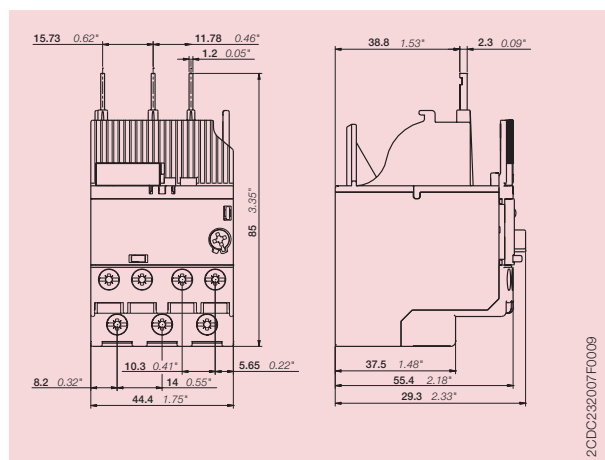

EF19

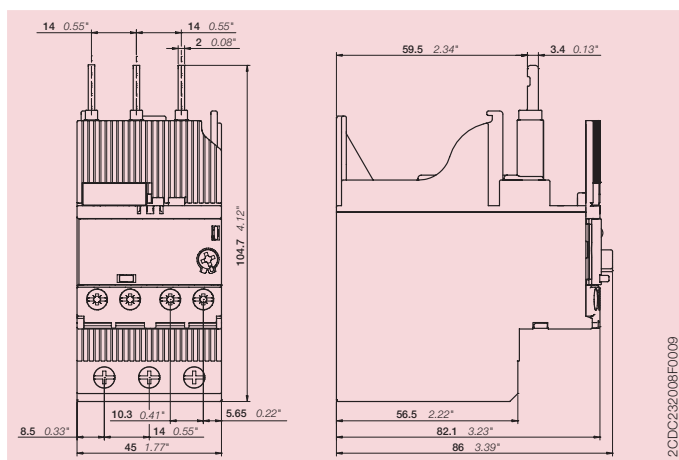

EF45

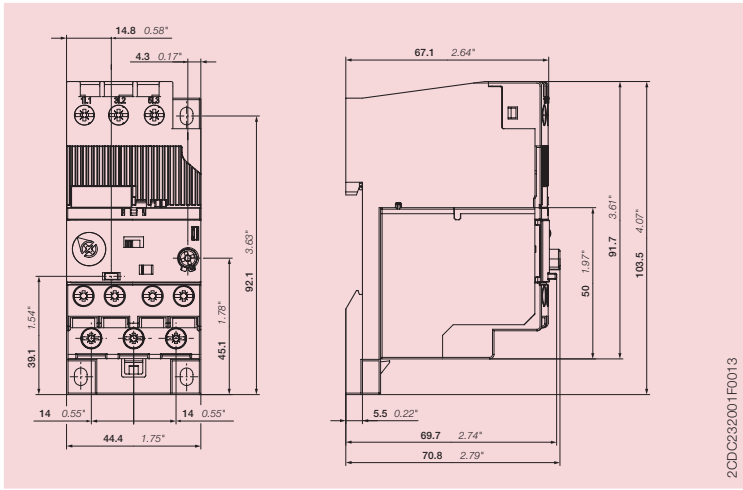

DB19EF + EF19

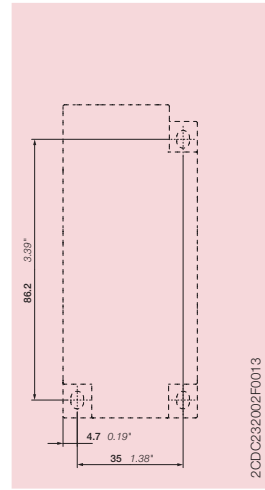

DB19EF drilling plan

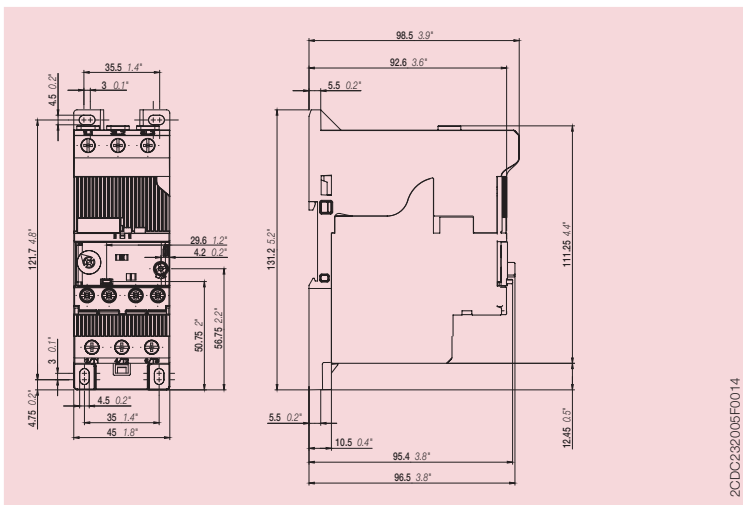

DB45EF + EF45

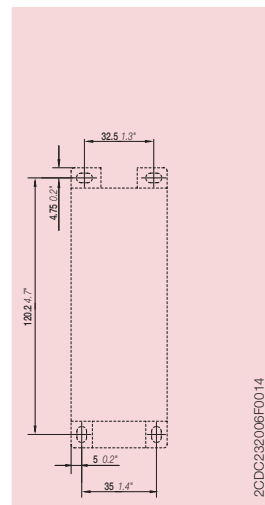

DB45EF drilling plan

Technical data IEC/EN

Data at $T_A = 40\text{ °C}$ and at rated values, if nothing else indicated

Main circuit

	2T1-4T2-6T3
Rated operational voltage U_e	690 V AC - V DC
Setting range - electronic overload protection	see table on page 1
Rated operational current AC-3 I_e	see upper value of setting range, table on page 3
Trip class	10E, 20E, 30E, selectable
Rated frequency	50/60 Hz
Number of poles	3
Resistance per pole	see table on page 3
Power loss per pole	see table on page 3
Short-circuit protective devices	see table on page 3

	2T1-4T2-6T3
Rated impulse withstand voltage U_{imp}	6 kV
Rated insulation voltage U_i	690 V
Pollution degree	3
Overvoltage category	up to III

Electrical connection	EF19	EF45	DB19EF	DB45EF	
Connecting capacity	solid	1/2 x 1 ... 4 mm ²	1/2 x 2.5 ... 16 mm ²	1 x 1 ... 4 mm ²	1/2 x 2.5 ... 16 mm ²
	stranded	1/2 x 1 ... 4 mm ²	1/2 x 2.5 ... 16 mm ²	1 x 1 ... 4 mm ²	1/2 x 2.5 ... 16 mm ²
	flexible with ferrule	1/2 x 0.75 ... 2.5 mm ²	1/2 x 2.5 ... 10 mm ²	1 x 0.75 ... 2.5 mm ²	1/2 x 2.5 ... 10 mm ²
	flexible with ferrule insulated	1/2 x 0.75 ... 2.5 mm ²	1/2 x 2.5 ... 10 mm ²	1 x 0.75 ... 2.5 mm ²	1/2 x 2.5 ... 10 mm ²
	flexible without ferrule	1/2 x 0.75 ... 2.5 mm ²	1/2 x 2.5 ... 10 mm ²	1 x 0.75 ... 2.5 mm ²	1/2 x 2.5 ... 10 mm ²
Stripping length	9 mm	13 mm	12 mm	15 mm	
Tightening torque	0.8 ... 1.5 Nm	2.3 ... 2.6 Nm	0.8 ... 1.5 Nm	0.8 ... 1.5 Nm	
Recommended screw driver	Pozidriv 2	Pozidriv 2	Pozidriv 2	Pozidriv 2	

Auxiliary circuit

		95-96, 97-98
Rated operational voltage U_e		600 V
Conventional free air thermal current I_{th}		6 A
Rated frequency		DC, 50/60 Hz
Number of poles		1NC + 1NO
Rated operational current I_e		
acc. to IEC/EN 60947-5-1 for utilization category		
at AC-15 at 110-120 V	NC, 95-96	3.00 A
	NO, 97-98	3.00 A
at AC-15 at 220-230-240 V	NC, 95-96	3.00 A
	NO, 97-98	3.00 A
at AC-15 at 440 V	NC, 95-96	1.10 A
	NO, 97-98	1.10 A
at AC-15 at 480-500 V	NC, 95-96	0.75 A
	NO, 97-98	0.75 A
at DC-13 at 24 V	NC, 95-96	1.50 A
	NO, 97-98	1.50 A
at DC-13 at 110-120-125 V	NC, 95-96	0.55 A
	NO, 97-98	0.55 A
at DC-13 at 250 V	NC, 95-96	0.27 A
	NO, 97-98	0.27 A
at DC-13 at 500 V	NC, 95-96	0.10 A
	NO, 97-98	0.10 A
Minimum switching capacity		12 V / 3 mA
Short-circuit protective devices		$\lambda = 10^{-7}$; $U_{kp} = 3$ V / 500.000 operating cycles fuse 6 A, Type gG
Isolation data		95-96, 97-98
Rated impulse withstand voltage U_{imp}		6 kV
Rated insulation voltage U_i		690 V
Pollution degree		3
Overvoltage category		up to III
Electrical connection		95-96, 97-98
Connecting capacity	solid	1/2 x 1 ... 4 mm ²
	stranded	1/2 x 1 ... 4 mm ²
	flexible with ferrule	1/2 x 0.75 ... 2.5 mm ²
	flexible with ferrule insulated	1/2 x 0.75 ... 2.5 mm ²
	flexible without ferrule	1/2 x 0.75 ... 2.5 mm ²
Stripping length		9 mm
Tightening torque		0.8 ... 1.2 Nm
Recommended screw driver		Pozidriv 2

General data

Duty time		100 %
Operating frequency without early tripping		up to 15 operations/h or 60 operations/h with 40 % duty ratio, if the motor breaking current $6 \times I_n$ and the motor starting time does not exceed 1 s
Dimensions (W x H x D)		see dimension drawing
Weight		see ordering data
Mounting		mount on the contactor and tighten the screws of the main circuit terminals or with single mounting kit on DIN rail (35 mm)
Mounting position		optional, position 1-6
Minimum distance to other units same type	horizontal	none
	vertical	not applicable
Minimum distance to electrical conductive board	horizontal	1.5 mm
	vertical	1.5 mm
Degree of protection	Housing / main circuit terminals	IP20 (depends on contactor)
Maximum operating altitude		up to 2000 m

Electromagnetic compatibility

Immunity acc. to IEC 60947-1		Environment A
Emission acc. to IEC 60947-1		Environment B

Environmental data

Ambient air temperature		
Operation	open - compensated	-25 ... +70 °C
	open	-25 ... +70 °C
Storage		-50 ... +85 °C
Ambient air temperature compensation		acc. to IEC/EN 60947-4-1
Resistance to vibrations acc. to IEC 60068-2-6		3g / 3 ... 150 Hz
Resistance to shock acc. to IEC 60068-2-27		25g / 11 ms

Standards / directives

Standards		IEC/EN 60947-1
		IEC/EN 60947-4-1
		IEC/EN 60947-5-1
		UL 60947-1
		UL 60947-4-1
Low Voltage Directive		2006/95/EC
EMC Directive		2004/108/EC
RoHS Directive		2002/95/EC

Technical data UL/CSA

Full load amps and short-circuit protective devices

Type	Full load amps (FLA)	Short circuit protective devices									
		480 V AC		480 V AC			600 V AC		600 V AC		600 V AC
		SCCR	Fuse K5 / RK5	SCCR	Circuit breaker	SCCR	Fuse K5 / RK5	SCCR	Fuse J	SCCR	Circuit breaker
EF19-0.32	0.32 A	50 kA	2 A - Class J Fuse	65 kA	15 A	5 kA	2 A	100 kA	2 A	-	-
EF19-1.0	1.00 A	50 kA	2 A	65 kA	15 A	5 kA	2 A	100 kA	2 A	-	-
EF19-2.7	2.70 A	50 kA	4 A	65 kA	15 A	5 kA	4 A	100 kA	4 A	-	-
EF19-6.3	6.30 A	50 kA	15 A	65 kA	35 A	5 kA	15 A	100 kA	15 A	-	-
EF19-18.9	18.9 A	50 kA	30 A	65 kA	35 A	5 kA	30 A	100 kA	30 A	10 kA	20 A
EF45-30	30.0 A	18 kA ¹⁾	150 A ¹⁾	65 kA	70 A	5 kA	150 A	100 kA	150 A	-	-
EF45-45	45.0 A	18 kA ¹⁾	250 A ¹⁾	65 kA	70 A	5 kA	250 A	100 kA	200 A	-	-

¹⁾ @ 600 V AC

Main circuit

Maximum operational voltage	600 V AC
Trip rating	125 % of FLA
Full load amps (FLA)	see table above
Short-circuit rating RMS symmetrical	see table above
Short-circuit protective devices	see table above

Electrical connection		EF19	EF45	DB19EF	DB45EF
Connecting capacity	stranded	1/2 x AWG 16 ... 10	1/2 x AWG 14 ... 6	1/2 x AWG 16 ... 10	1/2 x AWG 18 ... 10
	flexible without ferrule	1/2 x AWG 16 ... 10	1/2 x AWG 14 ... 6	1/2 x AWG 16 ... 10	1/2 x AWG 18 ... 10
Stripping length		9 mm	13 mm	12 mm	15 mm
Tightening torque		7 ... 13 lb-in	20 ... 22 lb-in	7 ... 13 lb-in	7 ... 13 lb-in
Recommended screw driver		Pozidriv 2 / M3.5	Pozidriv 2 / M5	Pozidriv 2 / M3	Pozidriv 2 / M3

Auxiliary circuit

Conventional thermal current	5 A
Making and breaking capacity	NC / NO B600, Q600

Electrical connection		
Connecting capacity	stranded	1/2 x AWG 18 ... 10
	flexible without ferrule	1/2 x AWG 18 ... 10
Stripping length		9 mm
Tightening torque		7 ... 11 lb-in
Recommended screw driver		Pozidriv 2

Contact us

ABB STOTZ-KONTAKT GmbH

Eppelheimer Straße 82
69123 Heidelberg, Germany
Phone: +49 (0) 6221 7 01-0
Fax: +49 (0) 6221 7 01-13 25
E-Mail: info.desto@de.abb.com

You can find the address of your
local sales organization on the
ABB home page
<http://www.abb.com/contacts>
-> Low Voltage Products and Systems

Note:

We reserve the right to make technical changes or modify the contents of this document without prior notice. With regard to purchase orders, the agreed particulars shall prevail. ABB AG does not accept any responsibility whatsoever for potential errors or possible lack of information in this document.

We reserve all rights in this document and in the subject matter and illustrations contained therein. Any reproduction, disclosure to third parties or utilization of its contents – in whole or in parts – is forbidden without prior written consent of ABB AG.

Copyright© 2014 ABB
All rights reserved

PROUDLY DISTRIBUTED BY

**FACTORY
CONTROLS**
03 5278 8222
sales@factorycontrols.com.au
www.factorycontrols.com.au
65 Douro Street, North Geelong Victoria 3215

Power and productivity
for a better world™

