

5

Interface Technology and Switching Devices

2017/2018



Interface technology and switching devices



Terminal blocks

- Terminal blocks



Power supplies, surge protection and device circuit breakers

- Surge protection and interference suppression filters
- Power supplies and UPS
- Protective devices



Sensor/actuator cabling and connectors

- Sensor/actuator cabling
- Cables and lines
- Connectors



Automation

- Lighting and signaling
- Fieldbus components and systems
- Functional safety
- HMIs and industrial PCs
- I/O systems
- Industrial cloud computing
- Industrial communication technology
- Software
- Controllers



Marking systems, tools and mounting material

- Marking and labeling
- Tools
- Installation and mounting material



PCB terminal blocks and PCB connectors

To quickly select a product, use our e-Paper.

i Web code: #1517

Find out more with the web code

On some of the catalog pages, you can find our webcode: a hash symbol followed by a four-digit number combination.

i Web code: #1234 (example)

This allows you to access information on our website quickly.

It could not be easier:

1. Go to the Phoenix Contact website
2. Enter # and the number combination in the search field
3. Get more information and product versions

Or use the direct link:

phoenixcontact.net/webcode/#1234





You will find the latest information and all new products directly in the product area of our website:

phoenixcontact.net/products

Also discover the Phoenix Contact catalog app interactively on your tablet.



Table of contents

Complete overview		4
Electronic switching devices and motor control		8
Measurement and control technology		54
Monitoring		198
Relay modules		282
System cabling for controllers		460
Technical information/index		602

Complete overview

Product range overview

Electronic switching devices and motor control



Motor management

Page 14



Hybrid motor starters

Page 23



Solid-state contactors

Page 40



IP67 motor starters

Page 50



Multiplexer for HART signals

Page 166



Process indicators and field devices

Page 178



Controllers
See Catalog 6

Monitoring



Energy meters, function and communication modules
Page 208



Test disconnect terminal blocks
See Catalog 1



Current transducers, current protector
Page 240



SOLARCHECK
Photovoltaic string monitoring
Page 256



Multifunctional time relays

Page 278



Function modules

Page 280



Lightning monitoring system
See Catalog 4



HMIs
See Catalog 6

Measurement and control technology



Frequency inverters

Page 52



Highly compact signal conditioners with plug-in connection technology

Page 68



(Ex i) signal conditioners with SIL functional safety

Page 140



(Ex i) signal conditioners with PL functional safety

Page 168



Complete packages for data logging

Page 215



Compressed air meters

Page 216



Current transformers

Page 220



Current transformers for retrofitting

Page 234



Charging technology for E-Mobility

See Catalog 2



Compact monitoring relays

Page 262



Multifunctional monitoring relays

Page 266



Ultra-narrow time relays

Page 276



Signal towers

See Catalog 6

Complete overview

Product range overview

Relay modules



RIFLINE complete

Page 296



PLC-INTERFACE

Page 372



Programmable logic relay system PLC logic
Page 426



DEK series

Page 437

System cabling for controllers



Controller-specific system cabling

Page 470



V8 adapters

Page 425



Retrofit and modernization components

Page 558



Universal modules

Page 566



Safety devices
See Catalog 6



Monitoring relays
Page 262



Time relays
Page 276



Universal cables
Page 582



Potential distributors
Page 598

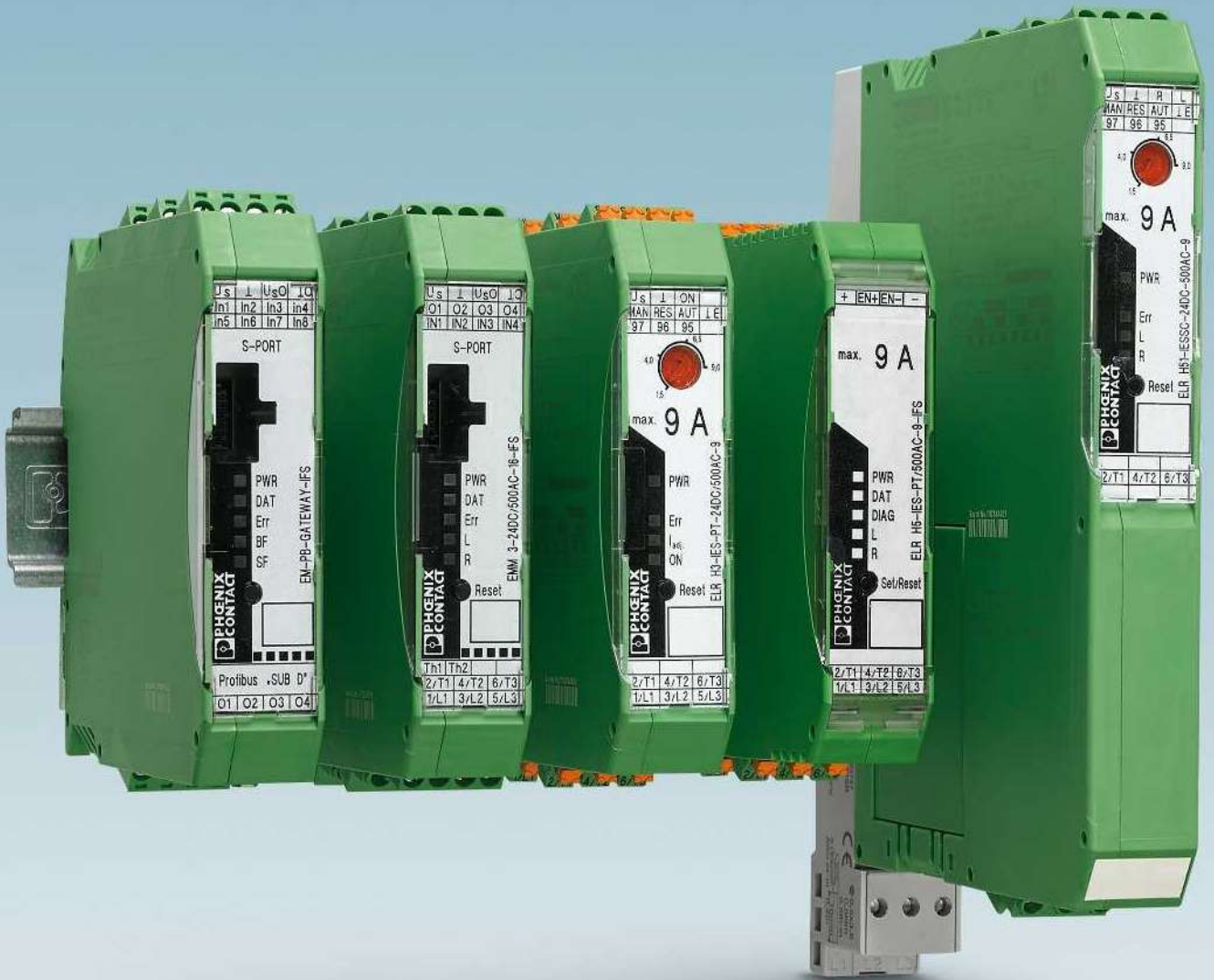

Electronic switching devices and motor control

Switching devices for starting, reversing, and protecting electric motors rank among the components used in automation technology. These components are designed redundantly for safety-sensitive applications. When it comes to reducing installation time and space requirements, CONTACTRON hybrid motor starters are the state-of-the-art alternative.

This is because CONTACTRON hybrid motor starters combine up to four functions in a single device. They are integrated into popular fieldbus systems via the Interface system connection or via the SmartWire-DT™ wiring system.

For protection of the entire system, the product range now includes the electronic motor manager (EMM). In addition to typical measured values such as voltage and current, the behavior of the system is monitored and protected by means of real power measurement. The process data in all popular fieldbus systems can be supplied with the gateway and evaluated by a controller.

Product range overview

Product overview	10
Electronic motor management	12
Network-capable hybrid motor starters with reversing function	20
Hybrid motor starters with reversing function	24
Network-capable hybrid motor starters with direct start function	26
Hybrid motor starters with direct start function	30
Hybrid motor starters with short-circuit protection	33
3-phase solid-state reversing contactors	40
3-phase solid-state contactors	42
Solid-state reversing contactor for DC motors	46
Single-phase solid-state contactors	48
IP67 motor starters	50
IP20 frequency inverters	52

Product overview

Motor management



Electronic motor management
Page 14



Gateways
Page 16



IFS extension module for the
Interface system
Page 17

Hybrid motor starters



Network-capable hybrid motor starters with
reversing function
Page 23



Hybrid motor starters with reversing function
Page 24



Network-capable hybrid motor starters with
direct start function
Page 29



Hybrid motor starters with direct start
function
Page 30

Solid-state contactors



3-phase solid-state reversing contactors
Page 40



3-phase solid-state contactors
Page 42



Semiconductor reversing contactor with
soft starter
Page 44



Solid-state reversing contactor for
DC motors
Page 46

IP67 motor starters



PROFINET motor starter for distributed use
Page 50



Stainless steel base, IP67 protection
Page 51

Frequency inverters



Inline frequency inverters for the
control cabinet
Page 52



Hybrid motor starters with short-circuit protection
Page 33



Continuous bridge for hybrid motor starters
Page 34



SmartWire-DT™ accessories
Page 36



Single-phase solid-state contactors
Page 48



Electronic motor management (EMM)

The electronic motor management modules offer all the advantages of modern real power monitoring.

The measuring and evaluation electronics for all performance classes. EMM offers the same functionality for all performance classes, only without a power section.

Power within limits

Monitoring is based on freely parameterizable switching and signaling thresholds for overload and underload detection. Identical or separate settings can be made for the thresholds for both directions of rotation. The real power consumed, calculated from three currents, voltages, and the phase angle, is used for parameterization. As it is independent of voltage fluctuations and drive load, the parameterization is thus much more precise than when only the current is taken into consideration. If a switching threshold is violated, an emergency shutdown of the motor is initiated immediately or with an adjustable "delay time". In addition, a message is sent via an output.

This state can only be deactivated via a defined reset. If the real power consumed is determined as being above or below the message thresholds, all that occurs is that a

check-back is returned for the duration for which the module was addressed.

In addition, signals are generated by the module for the recognition of the direction of rotation. Asymmetry and phase failures are detected and signaled.

Permanent status monitoring with high scanning rates and the fast semiconductor switch enable complete system protection, including motor protection.

Without any extra wiring - and with just a single device - pumps, actuating drives, fans, and tools are monitored for proper functioning, contamination (filter or similar), and wear. The adjustable "inrush suppression" time can be used to mask out the switching operation from the monitoring process.

Interface system

The Interface system (IFS) consists of devices which can be connected to each other via the DIN rail connector. A gateway with up to 32 IFS devices forms the head of Interface system. The station is managed by the gateway.

Interface system properties:

- Use of the Interface system via the DIN rail connector for the purpose of parameterization, diagnostics, and the exchange of data with each other
- Compatible with defined IFS accessories
- 24 V supply of the devices (e.g., EMM...IFS, ELR...IFS, EM-GATEWAY-IFS) via the DIN rail connector

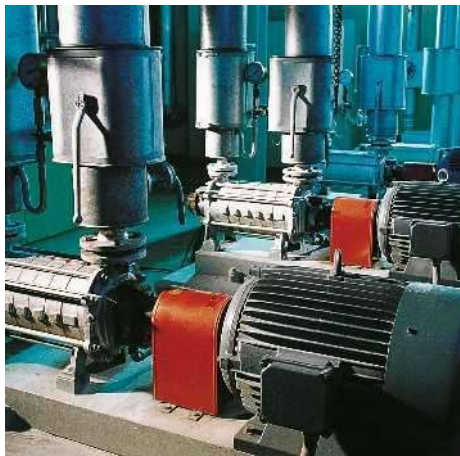

Protection against dry running, blocking, and cavitation, warning thresholds to indicate filter contamination.



Protection against blocking, warning thresholds for bearing wear and other cases that trigger overload.



Protection against blocking and broken tools, warning thresholds for tool and bearing wear.

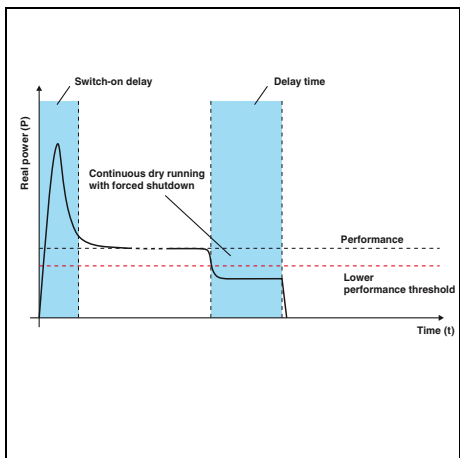

In the case of motor-driven pumps, the lower performance threshold provides reliable protection against hazardous dry running.

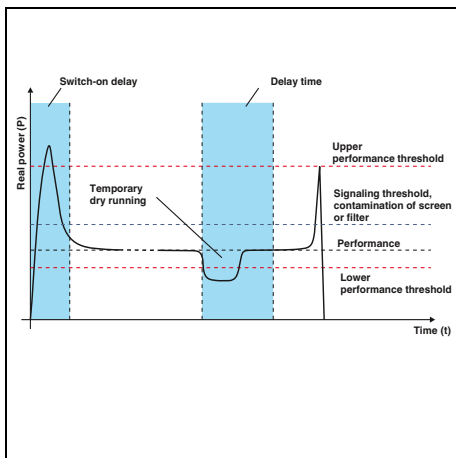

Forced shutdown of the drive is delayed by the “delay time”. This prevents forced shutdown in the event of air bubbles.

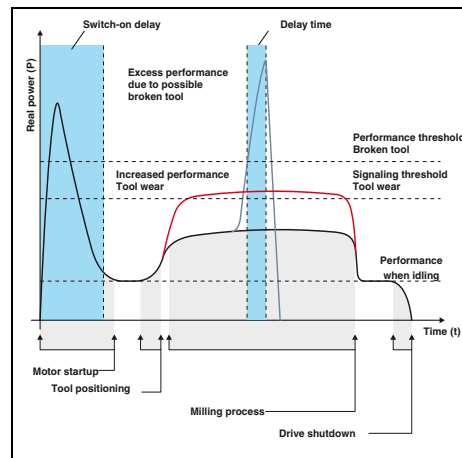

Machine tools are monitored and protected in a similar way when drilling, milling or grinding. If the feed value on a milling machine is set too high, a tool may break in the “worst-case” scenario. The power threshold, parameterized accordingly, can be used to resolve this issue.

Additionally, a message threshold signals tool wear in advance.

Motor management

Electronic motor management

EMM motor management (with or without current transformer) for all performance classes monitors and protects 3-phase loads, such as electrical drives.

- Freely parameterizable signaling or switching thresholds
- Digital outputs control external switching elements
- Optional connection to the Interface system (e.g., IFS gateways) via DIN rail connector



Allows the use of external current transformers



With integrated current transformers

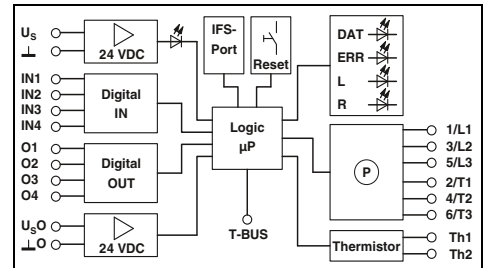
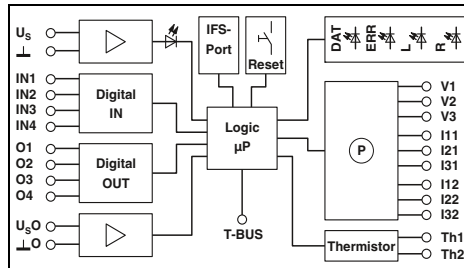

Technical data

Input data		
Rated control supply voltage U_s	24 V DC	230 V AC
Control supply voltage range	19.2 V DC ... 30 V DC	92 V AC ... 253 V AC
Rated control supply current I_s at U_s	25 mA	10 mA
Input data of digital inputs	EMM 3- 24DC/500AC-IFS	EMM 3-230AC/500AC-IFS
Number of inputs	4 (IN1 - IN4)	4 (IN1 - IN4)
Rated actuating voltage U_c	24 V DC	230 V AC
Rated actuating current I_c	3.3 mA	3.5 mA
Power measurement		
Voltage measuring input	42 V AC ... 575 V AC	42 V AC ... 575 V AC
Nominal current, voltage measuring input	< 0.5 mA	< 0.5 mA
Current measuring input	5 A (Secondary external converter)	5 A (Secondary external converter)
Output data for confirmation contacts		
O1 - O4 in the case of 1 signal	24 V DC (semiconductor output) / 500 mA	230 V AC (Relay output) / 500 mA
General data		
Rated insulation voltage	500 V	
Rated surge voltage	6 kV	6 kV
Ambient temperature (operation)	-25 °C ... 70 °C	
Standards/regulations	DIN EN 50178 / EN 60947 / EN 60947-4-2	
Degree of protection in acc. with IEC 60529/EN 60529	IP20	
Mounting position	Vertical (horizontal DIN rail)	
Screw connection solid/stranded/AWG	0.2 - 2.5 mm ² / 0.2 - 2.5 mm ² / 24 - 14	
Dimensions	22.5 mm / 99 mm / 114.5 mm	
EMC note	Class A product, see page 605	

Technical data

Input data		
Rated control supply voltage U_s	24 V DC	230 V AC
Control supply voltage range	19.2 V DC ... 30 V DC	92 V AC ... 253 V AC
Rated control supply current I_s at U_s	25 mA	10 mA
Input data of digital inputs	EMM 3- 24DC/500AC-16-IFS	EMM 3-230AC/500AC-16-IFS
Number of inputs	4 (IN1 - IN4)	4 (IN1 - IN4)
Rated actuating voltage U_c	24 V DC	230 V AC
Rated actuating current I_c	3.3 mA	3.5 mA
Power measurement		
Voltage measuring input	42 V AC ... 575 V AC	42 V AC ... 575 V AC
Nominal current, voltage measuring input	< 0.5 mA	< 0.5 mA
Current measuring input	max. 16 A	max. 16 A
Output data for confirmation contacts		
O1 - O4 in the case of 1 signal	24 V DC (semiconductor output) / 500 mA	230 V AC (Relay output) / 500 mA
General data		
Rated insulation voltage	500 V	
Rated surge voltage	6 kV	6 kV
Ambient temperature (operation)	-25 °C ... 70 °C	
Standards/regulations	DIN EN 50178 / EN 60947 / EN 60947-4-2	
Degree of protection in acc. with IEC 60529/EN 60529	IP20	
Mounting position	Vertical (horizontal DIN rail)	
Screw connection solid/stranded/AWG	0.2 - 2.5 mm ² / 0.2 - 2.5 mm ² / 24 - 14	
Dimensions	22.5 mm / 99 mm / 114.5 mm	
EMC note	Class A product, see page 605	

Ordering data

Description			
Electronic motor management			

Type	Order No.	Pcs./ Pkt.
EMM 3- 24DC/500AC-IFS	2297497	1
EMM 3-230AC/500AC-IFS	2297507	1

Ordering data

Type	Order No.	Pcs./ Pkt.
EMM 3- 24DC/500AC-16-IFS	2297523	1
EMM 3-230AC/500AC-16-IFS	2297536	1

Accessories

Configuration package for the EMM...IFS, comprising CONTACTRON-DTM-IFS, USB programming adapter, and user manual on CD	MM-CONF-SET	2297992	1
Programming adapter for configuring modules with S-PORT interface	IFS-USB-PROG-ADAPTER	2811271	1
DIN rail connector	ME 22,5 TBUS 1,5/ 5-ST-3,81 GN	2707437	50
Voltage transducer for 690 V , for EMM 3-.../500AC-IFS, comprising 3 terminal blocks and cover	UT 4-MTD-R/CVC 690/SET	2901667	1
Multi-functional memory module for the Interface system			
- Flat design	IFS-CONFSTICK	2986122	1
- Tall design	IFS-CONFSTICK-L	2901103	1
MINI COMBICON connectors			
- Female contact	MC 1,5/ 5-ST-3,81	1803604	250
- Male contact	IMC 1,5/ 5-ST-3,81	1857919	50

Type	Order No.	Pcs./ Pkt.
MM-CONF-SET	2297992	1
IFS-USB-PROG-ADAPTER	2811271	1
ME 22,5 TBUS 1,5/ 5-ST-3,81 GN	2707437	50
UT 4-MTD-R/CVC 690/SET	2901667	1
IFS-CONFSTICK	2986122	1
IFS-CONFSTICK-L	2901103	1
MC 1,5/ 5-ST-3,81	1803604	250
IMC 1,5/ 5-ST-3,81	1857919	50

Type	Order No.	Pcs./ Pkt.
MM-CONF-SET	2297992	1
IFS-USB-PROG-ADAPTER	2811271	1
ME 22,5 TBUS 1,5/ 5-ST-3,81 GN	2707437	50
IFS-CONFSTICK	2986122	1
IFS-CONFSTICK-L	2901103	1
MC 1,5/ 5-ST-3,81	1803604	250
IMC 1,5/ 5-ST-3,81	1857919	50

Electronic motor management

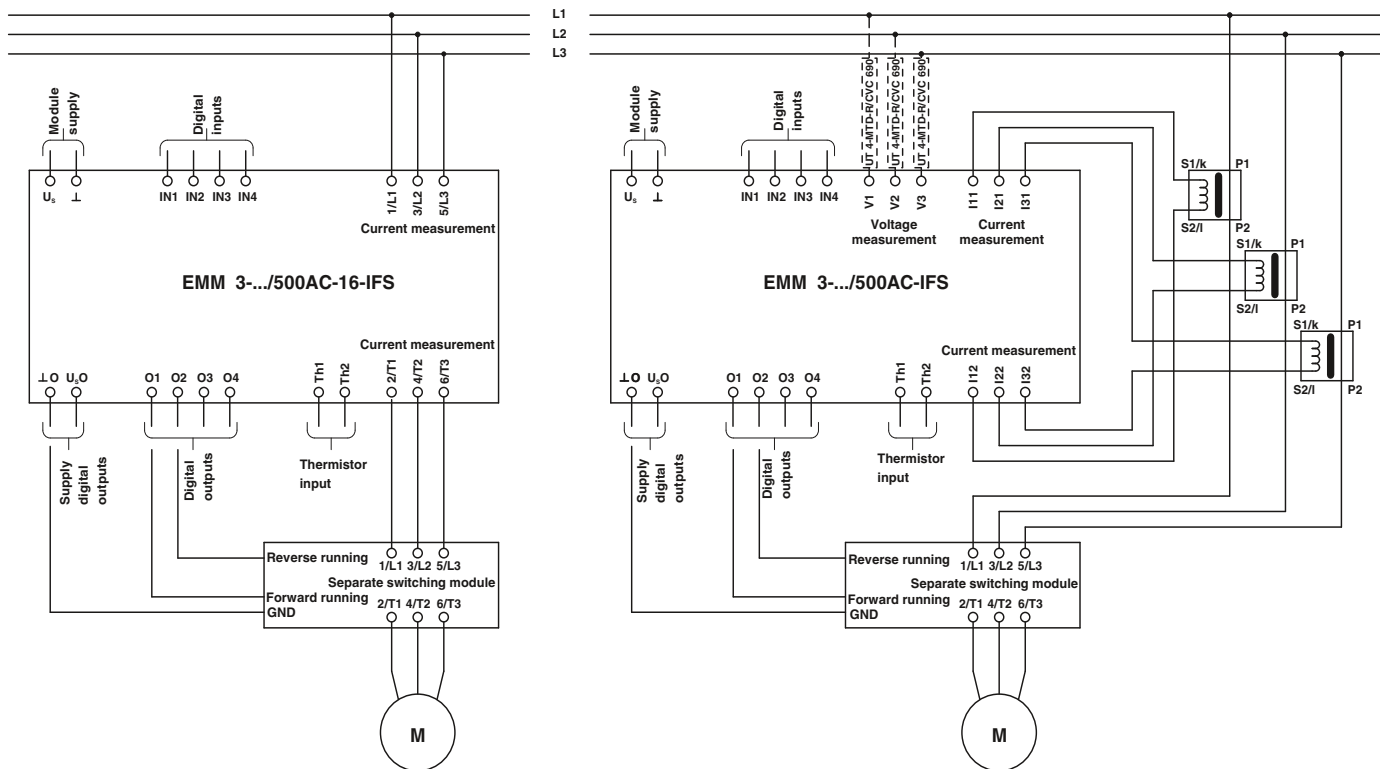

The electronic motor management modules (EMM) offer all the advantages of modern real power monitoring. Every 6.6 ms, the real power consumed of a drive system or another 3-phase load is determined based on three currents, voltages, and the phase angle. Currents up to 16 A are directly acquired and currents >16 A are fed through external converters. Separate mechanical or electronic switching elements, which take care of the actual load switching, are controlled via digital outputs. The EMM is designed to reliably protect connected loads - irrespective of their power consumption - against overload and underload, and to provide continuous status monitoring.

Up to 8 freely parameterizable switching, message thresholds and up to four freely configurable inputs and outputs enable the protection of electrical drives and the system.

The EMM modules can record the following data:

- Apparent, real, and reactive power
- Currents and voltages
- Phase angle
- Switching-cycle and operating-hours
- Power meter

Additional functions:

- Adjustable bimetal function class 5-30
- Thermistor monitor
- Recording measured values
- GATEWAY connection via DIN rail connector
- Pre-configured motor feeders such as reversing starters, star-delta starters, etc.

With the EMM modules, complete "driving curves" are recorded, which can be used for the system documentation, for example.

With the forward running, reverse running, reversing, and limit switch (with integrated restart lock) operating modes, actuators and control drives, pumps and similar are switched and monitored for wear.

Current transformer

The external converters should be selected with a secondary nominal current of 5 A. The primary current is determined by the current consumption of the load (refer to connection diagram). For suitable current transformers, see Interface catalog.

DIN rail connectors

The DIN rail connectors (Order No. 2707437) are used to supply several EMMs with 24 V DC or to couple up to 32 EMMs (for example) to the PROFIBUS-GATEWAY-IFS.

Switching element

Depending on the requirements for the actual load switching, an electromechanical contactor or a reversing contactor combination or a solid-state contactor/solid-state reversing contactor is used. These switching elements are controlled via the digital outputs of the EMM modules.

Motor management

IFS gateways for Interface system devices

EM...GATEWAY-IFS for connecting Interface system devices (IFS) to popular bus systems: PROFIBUS DP, Modbus, Modbus/TCP, DeviceNet™, CANopen®, and PROFINET, EtherNet/IP™.

- Communication via DIN rail connector with up to 32 Interface system devices, such as EMM...IFS- and ELR...IFS modules
- Equipped with freely parameterizable digital inputs and outputs
- Digital switching outputs for direct control



IFS gateways

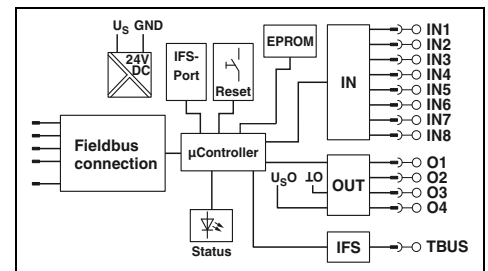

Technical data

Input data	
Rated control supply voltage U_s	24 V DC -20 % ... +25 %
Rated control supply current I_s	85 mA (plus load current of the outputs)
Input circuit	Reverse polarity protection
Digital inputs	
Number of inputs	8
Rated actuating voltage U_C	24 V DC \pm 20 %
Rated actuating current I_C	3 mA
Input circuit	Reverse polarity protection
Digital outputs	
Number of outputs	4
Maximum switching voltage	23 V DC ($U_B - U_{resid.}$ of the output)
Max. switching current	500 mA
Residual voltage	1 V
Output protection	Parallel protection against polarity reversal, pay attention to the fuse
General data	
Ambient temperature (operation)	-35 °C ... 50 °C
Nominal operating mode	100% operating factor
Standards/regulations	EN 50178
Degree of protection	IP20
Mounting position/mounting	any / In rows with zero spacing
Connection data solid/stranded/AWG	0.2 ... 2 mm ² / 0.2 ... 2.5 mm ² / 12 - 24
Dimensions	22.5 mm / 99 mm / 114.5 mm
EMC note	Class A product, see page 605

Ordering data

Description	Type	Order No.	Pcs./Pkt.
IFS gateway for PROFIBUS DP	EM-PB-GATEWAY-IFS	2297620	1
RS-232	EM-RS232-GATEWAY-IFS	2901526	1
RS-485	EM-RS485-GATEWAY-IFS	2901527	1
Modbus/TCP	EM-MODBUS-GATEWAY-IFS	2901528	1
DeviceNet™	EM-DNET-GATEWAY-IFS	2901529	1
CANopen®	EM-CAN-GATEWAY-IFS	2901504	1
PROFINET	EM-PNET-GATEWAY-IFS	2904472	1
EtherNet/IP™	EM-ETH-GATEWAY-IFS	2901988	1

Accessories

Configuration package for the EMM...IFS, comprising CONTACTRON-DTM-IFS, USB programming adapter, and user manual on CD	MM-CONF-SET	2297992	1
Programming adapter for configuring modules with S-PORT interface	IFS-USB-PROG-ADAPTER	2811271	1
DIN rail connector	ME 22,5 TBUS 1,5/ 5-ST-3,81 GN	2707437	50
MINI COMBICON connectors	MC 1,5/ 5-ST-3,81	1803604	250
- Female contact	IMC 1,5/ 5-ST-3,81	1857919	50
- Male contact			

new

IFS extension module for the Interface system

EM-D-8/4... IFS digital extension module for the Interface system (IFS). For more complex applications, in order to process additional signals in the field.

- Communication with an IFS gateway via DIN rail connector as the slave
- Freely configurable digital inputs and outputs



IFS extension module

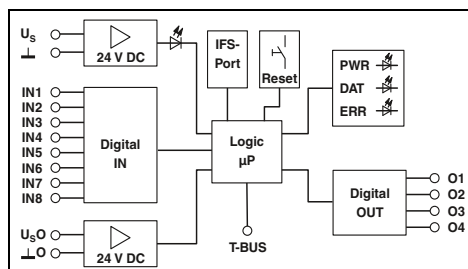

Technical data

Input data	
Rated control supply voltage U_s	24 V DC -20 % ... +25 %
Rated control supply current I_s	85 mA (plus load current of the outputs)
Input circuit	Reverse polarity protection
Digital inputs	
Number of inputs	8
Rated actuating voltage U_c	24 V DC ± 20 %
Rated actuating current I_c	3 mA
Input circuit	Reverse polarity protection
Digital outputs	
Number of outputs	4
Maximum switching voltage	23 V DC ($U_B - U_{resid.}$ of the output)
Max. switching current	500 mA (per output)
Residual voltage	1 V
Output protection	Parallel protection against polarity reversal, pay attention to the fuse
General data	
Ambient temperature (operation)	-35 °C ... 50 °C
Nominal operating mode	100% operating factor
Standards/regulations	EN 61131-2
Degree of protection	IP20
Mounting position/mounting	any / In rows with zero spacing
Connection data solid/stranded/AWG	0.2 ... 2 mm ² / 0.2 ... 2.5 mm ² / 12 - 24
Dimensions	22.5 mm / 99 mm / 114.5 mm

Ordering data

Description	Type	Order No.	Pcs./Pkt.
IFS extension module, with 8 digital inputs and 4 digital outputs	EM-D-8/4-24DC-IFS	2904473	1

Accessories

Configuration package for the EMM...IFS, comprising CONTACTRON-DTM-IFS, USB programming adapter, and user manual on CD	MM-CONF-SET	2297992	1
Programming adapter for configuring modules with S-PORT interface	IFS-USB-PROG-ADAPTER	2811271	1
DIN rail connector	ME 22,5 TBUS 1,5/ 5-ST-3,81 GN	2707437	50
MINI COMBICON connectors			
- Female contact	MC 1,5/ 5-ST-3,81	1803604	250
- Male contact	IMC 1,5/ 5-ST-3,81	1857919	50



The CONTACTRON hybrid motor starters combine up to four functions in one device: motor starter, reversing function, motor protection against overload, and emergency stop.

In addition to standard devices for parallel wiring, network-capable versions, which can be integrated into fieldbus environments, are also available.

CONTACTRON hybrid motor starter technology is a microprocessor-controlled combination of wear-free solid-state technology and robust relay technology. The semiconductors execute the wear-prone on and off switching procedures, while the relays only conduct low-loss current. This enables soft switching and considerably reduces the load on the relay contacts.

Switch motors safely and reliably with compact hybrid motor starters.

The devices are used wherever three-phase asynchronous motors, from 50 W to 3 kW, need to be reversed and protected. The product range of hybrid motor starters consists of direct and reversing starters, which are available with various functions such as emergency stop and motor protection.



Hybrid motor starter with up to four functions in one device: forward running, reverse running, motor protection, and emergency stop.



Short-circuit-proof hybrid motor starter with integrated fuses, for mounting on 35 mm DIN rail and 60 mm busbar systems.



Connection of hybrid motor starters in a bus system via SmartWire-DT™. Gateways are available for the most important bus systems: PROFIBUS, Modbus/TCP, EtherNet/IP™, and CANopen®.



Connection of the hybrid motor starter to a bus system via the IFS Interface system. Gateways are available for the most important bus systems: PROFIBUS DP, Modbus/TCP, EtherNet/IP™, CANopen®, DeviceNet™, PROFINET, etc.

Hybrid motor starters

Network-capable hybrid motor starter with reversing function

These 3-phase hybrid motor starters offer up to four functions: forward running, reverse running, motor protection, and emergency stop up to SIL3 / PL e.

They offer the following advantages:

- Bus connection via Interface system (IFS) or via IO-Link
- Reduction in wiring
- Bi-metal function, adjustable up to 9 A
- Long service life
- Space-saving
- 3-phase loop bridging
- Safety level according to:
 - IEC 61508-1: SIL3
 - ISO 13849: PL e

Notes:
Type of housing: Polyamide PA, non-reinforced, color: green.
Marking systems and mounting material See Catalog 3



Motor protection, emergency stop, and Interface system support

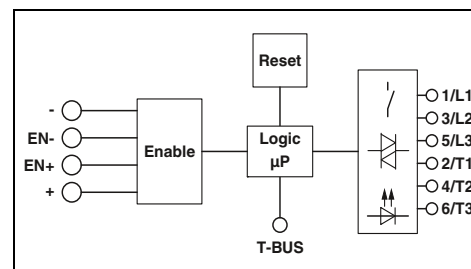

Technical data

Input data	
Rated supply voltage U_s	24 V DC
Control supply voltage range	19.2 V DC ... 30 V DC
Rated control supply current I_c at U_s	60 mA
Rated actuating voltage U_c EN+	24 V DC
Actuating voltage range	19.2 V DC ... 30 V DC
Rated actuating current I_c at U_c	7 mA
Input circuit	Reverse polarity protection, Surge protection
Operating voltage / status / error indicator	Green LED / Yellow LED / Red LED
Output data load side	
Operating voltage range	42 V AC ... 550 V AC
Output protection	Surge protection
General data	
Rated insulation voltage	550 V
Rated surge voltage	6 kV
Ambient temperature (operation)	-5 °C ... 60 °C (observe derating)
Standards/regulations	IEC 60947-1 / EN 60947-4-2 / IEC 61508 / ISO 13849
Mounting position	vertical (horizontal DIN rail, motor output below)
Mounting	
Connection data solid/stranded/AWG	alignable, for spacing see derating
Dimensions	0.2 - 2.5 mm ² / 0.2 - 2.5 mm ² / 24 - 14 22.5 mm / 99 mm / 114.5 mm

Rated supply voltage U_s	24 V DC
Control supply voltage range	19.2 V DC ... 30 V DC
Rated control supply current I_c at U_s	60 mA
Rated actuating voltage U_c EN+	24 V DC
Actuating voltage range	19.2 V DC ... 30 V DC
Rated actuating current I_c at U_c	7 mA
Input circuit	Reverse polarity protection, Surge protection
Operating voltage / status / error indicator	Green LED / Yellow LED / Red LED
Output data load side	
Operating voltage range	42 V AC ... 550 V AC
Output protection	Surge protection
General data	
Rated insulation voltage	550 V
Rated surge voltage	6 kV
Ambient temperature (operation)	-5 °C ... 60 °C (observe derating)
Standards/regulations	IEC 60947-1 / EN 60947-4-2 / IEC 61508 / ISO 13849
Mounting position	vertical (horizontal DIN rail, motor output below)
Mounting	
Connection data solid/stranded/AWG	alignable, for spacing see derating
Dimensions	0.2 - 2.5 mm ² / 0.2 - 2.5 mm ² / 24 - 14 22.5 mm / 99 mm / 114.5 mm

Ordering data

Description
Load current 0.075 A ... 0.6 A
Screw connection
Push-in connection
Load current 0.18 A ... 3 A
Screw connection
Push-in connection
Load current 1.5 A ... 9 A
Screw connection
Push-in connection

Type	Order No.	Pcs./Pkt.
ELR H5-IES-SC/500AC-06-IFS	2905151	1
ELR H5-IES-PT/500AC-06-IFS	2905138	1
ELR H5-IES-SC/500AC-3-IFS	2905152	1
ELR H5-IES-PT/500AC-3-IFS	2905139	1
ELR H5-IES-SC/500AC-9-IFS	2905153	1
ELR H5-IES-PT/500AC-9-IFS	2905140	1

Accessories

DIN rail connector
ME 22.5 TBUS 1,5/ 5-ST-3,81 GN

ME 22.5 TBUS 1,5/ 5-ST-3,81 GN	2707437	50
--------------------------------	---------	----

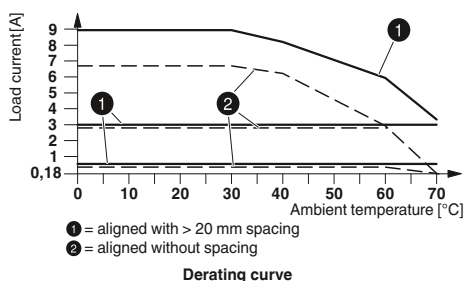



Motor protection and Interface system support



new

Motor protection, emergency stop, and IO-Link support

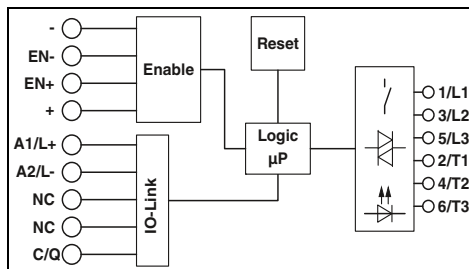
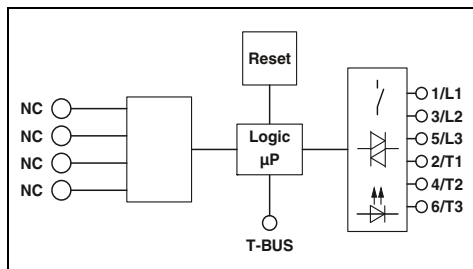

Technical data

Technical data

24 V DC
 19.2 V DC ... 30 V DC
 60 mA
 -
 -
 -
 Reverse polarity protection , Surge protection
 Green LED / Yellow LED / Red LED

42 V AC ... 550 V AC
 Surge protection

550 V
 6 kV
 -5 °C ... 60 °C (observe derating)
 IEC 60947-1 / EN 60947-4-2
 vertical (horizontal DIN rail, motor output below)

alignable, for spacing see derating
 0.2 - 2.5 mm² / 0.2 - 2.5 mm² / 24 - 14
 22.5 mm / 99 mm / 114.5 mm

24 V DC
 19.2 V DC ... 30 V DC
 65 mA
 24 V DC
 19.2 V DC ... 30 V DC
 7 mA
 Reverse polarity protection , Surge protection
 Green LED / Yellow LED / Red LED

42 V AC ... 550 V AC
 Surge protection

550 V
 6 kV
 -5 °C ... 55 °C (observe derating)
 IEC 60947-1 / EN 60947-4-2 / IEC 61508 / ISO 13849
 vertical (horizontal DIN rail, motor output below)

alignable, for spacing see derating
 0.2 - 2.5 mm² / 0.2 - 2.5 mm² / 24 - 14
 22.5 mm / 99 mm / 114.5 mm

Ordering data

Ordering data

Type	Order No.	Pcs./ Pkt.
ELR H5-I-SC/500AC-06-IFS	2905157	1
ELR H5-I-PT/500AC-06-IFS	2905144	1
ELR H5-I-SC/500AC-3-IFS	2905159	1
ELR H5-I-PT/500AC-3-IFS	2905146	1
ELR H5-I-SC/500AC-9-IFS	2905160	1
ELR H5-I-PT/500AC-9-IFS	2905147	1

Type	Order No.	Pcs./ Pkt.
ELR H5-IES-PT/500AC-3-IOL	2908669	1
ELR H5-IES-PT/500AC-9-IOL	2908670	1

Accessories

Accessories

ME 22,5 TBUS 1,5/ 5-ST-3,81 GN	2707437	50
--------------------------------	---------	----

--	--	--

Hybrid motor starters

Network-capable hybrid motor starter with reversing function

These 3-phase hybrid motor starters offer up to four functions: forward running, reverse running, motor protection, and emergency stop up to SIL3 / PL e.

They offer the following advantages:

- Connection to SmartWire-DT™ (SWD)
 - 22.5 mm wide
 - Reduction in wiring
 - Bi-metal function, adjustable up to 9 A
 - Long service life
 - Space-saving
 - 3-phase loop bridging
- Safety level according to:
- IEC 61508-1: SIL3
 - ISO 13849: PL e



Motor protection, emergency stop, and SmartWire-DT™ support

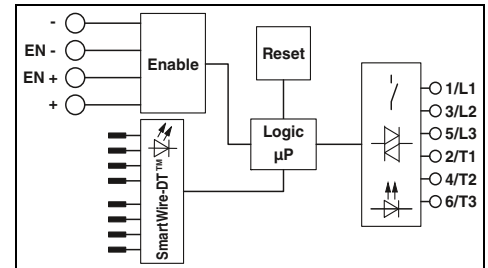

Technical data

Input data	Rated supply voltage U_s	24 V DC
Control supply voltage range	19.2 V DC ... 30 V DC	
Rated control supply current I_c at U_s	60 mA	
Rated actuating voltage U_c EN+	24 V DC	
Actuating voltage range	19.2 V DC ... 30 V DC	
Rated actuating current I_c at U_c	7 mA	
Input circuit	Reverse polarity protection, Surge protection	
Operating voltage / status / error indicator	Green LED / Yellow LED / Red LED	
Output data load side		
Operating voltage range	42 V AC ... 550 V AC	
Output protection	Surge protection	
General data		
Rated insulation voltage	550 V	
Rated surge voltage	6 kV	
Ambient temperature (operation)	-5 °C ... 55 °C (observe derating)	
Standards/regulations	IEC 60947-1 / EN 60947-4-2 / IEC 61508 / ISO 13849	
Mounting position	vertical (horizontal DIN rail, motor output below)	
Mounting	alignable, for spacing see derating	
Connection data solid/stranded/AWG	0.2 - 2.5 mm ² / 0.2 - 2.5 mm ² / 24 - 14	
Dimensions	22.5 mm / 99 mm / 114.5 mm	

Ordering data

Description	Type	Order No.	Pcs./Pkt.
Load current 0.075 A ... 0.6 A Push-in connection	ELR H5-IES-PT-SWD/500AC-06	2903933	1
Load current 0.18 A ... 2.4 A Push-in connection	ELR H5-IES-PT-SWD/500AC-3	2903934	1
Load current 1.5 A ... 9 A Push-in connection	ELR H5-IES-PT-SWD/500AC-9	2903935	1

Accessories

Device plug, 8-pos.	SWD4-8SF2-5 PXC	2903107	10
----------------------------	-----------------	---------	----

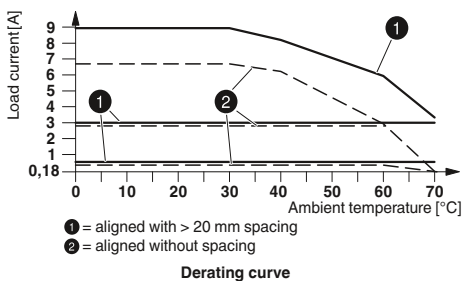



Motor protection and SmartWire-DT™ support

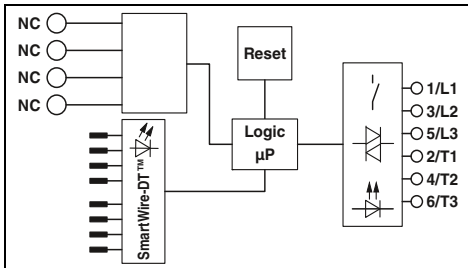

Technical data

24 V DC
 19.2 V DC ... 30 V DC
 60 mA
 -
 -
 -

Reverse polarity protection , Surge protection
 Green LED / Yellow LED / Red LED

42 V AC ... 550 V AC
 Surge protection

550 V
 6 kV
 -5 °C ... 55 °C (observe derating)
 IEC 60947-1 / EN 60947-4-2
 vertical (horizontal DIN rail, motor output below)

alignable, for spacing see derating
 0.2 - 2.5 mm² / 0.2 - 2.5 mm² / 24 - 14
 22.5 mm / 99 mm / 114.5 mm

Ordering data

Type	Order No.	Pcs./ Pkt.
ELR H5-I-PT-SWD/500AC-06	2905073	1
ELR H5-I-PT-SWD/500AC-3	2905074	1
ELR H5-I-PT-SWD/500AC-9	2905075	1

Accessories

SWD4-8SF2-5 PXC	2903107	10
-----------------	-------------------------	----

Hybrid motor starters

Hybrid motor starters with reversing function

These 3-phase hybrid motor starters offer up to four functions: forward running, reverse running, motor protection, and emergency stop up to SIL3 / PL e.

They offer the following advantages:

- 22.5 mm wide
- Reduction in wiring
- Bi-metal function, adjustable up to 9 A
- Long service life
- Space-saving
- 3-phase loop bridging
- Safety level according to:
 - IEC 61508-1: SIL3
 - ISO 13849: PL e

Notes:
Type of housing: Polyamide PA, non-reinforced, color: green.
Marking systems and mounting material See Catalog 3



Motor protection and emergency stop

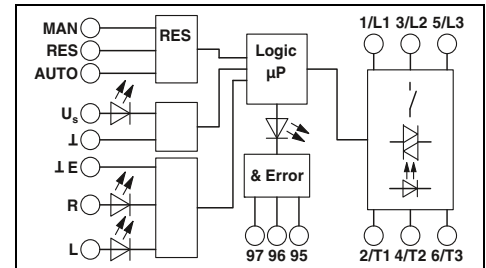

Technical data

Input data		
Rated control supply voltage U_s	24 V DC	230 V AC (50/60 Hz)
Control supply voltage range	19.2 V DC ... 30 V DC	85 V AC ... 253 V AC
Rated control supply current I_s at U_s	40 mA	4 mA
Rated actuating voltage U_c R/L	24 V DC	230 V AC
Actuating voltage range	19.2 V DC ... 30 V DC	85 V AC ... 253 V AC
Rated actuating current I_c at U_c	5 mA	7 mA
Input circuit	Reverse polarity protection ,	Surge protection
Operating voltage / status / error indicator	Green LED / Yellow LED / Red LED	
Output data load side		
Operating voltage range	42 V AC ... 550 V AC	42 V AC ... 550 V AC
Output protection	Surge protection	
General data		
Rated insulation voltage	500 V	
Rated surge voltage	6 kV	
Ambient temperature (operation)	-25 °C ... 70 °C (observe derating)	
Standards/regulations	IEC 60947-1 / IEC 60947-4-2 / IEC 61508 / ISO 13849	
Mounting position	vertical (horizontal DIN rail, motor output below)	
Mounting		
Connection data solid/stranded/AWG	alignable, for spacing see derating 0.2 - 2.5 mm ² / 0.2 - 2.5 mm ² / 24 - 14	
Dimensions	W / H / D 22.5 mm / 99 mm / 114.5 mm	

Rated control supply voltage U_s	24 V DC	230 V AC (50/60 Hz)
Control supply voltage range	19.2 V DC ... 30 V DC	85 V AC ... 253 V AC
Rated control supply current I_s at U_s	40 mA	4 mA
Rated actuating voltage U_c R/L	24 V DC	230 V AC
Actuating voltage range	19.2 V DC ... 30 V DC	85 V AC ... 253 V AC
Rated actuating current I_c at U_c	5 mA	7 mA
Input circuit	Reverse polarity protection ,	Surge protection
Operating voltage / status / error indicator	Green LED / Yellow LED / Red LED	
Output data load side		
Operating voltage range	42 V AC ... 550 V AC	42 V AC ... 550 V AC
Output protection	Surge protection	
General data		
Rated insulation voltage	500 V	
Rated surge voltage	6 kV	
Ambient temperature (operation)	-25 °C ... 70 °C (observe derating)	
Standards/regulations	IEC 60947-1 / IEC 60947-4-2 / IEC 61508 / ISO 13849	
Mounting position	vertical (horizontal DIN rail, motor output below)	

Description
Load current 0.075 A ... 0.6 A
Screw connection
Push-in connection
Load current 0.18 A ... 2.4 A
Screw connection
Push-in connection
Screw connection
Load current 1.5 A ... 9 A
Screw connection
Push-in connection
Screw connection
Load current 0 A ... 9 A
Screw connection
Screw connection

Ordering data

Type	Order No.	Pcs./ Pkt.
ELR H5-IES-SC- 24DC/500AC-0,6	2900582	1
ELR H5-IES-PT- 24DC/500AC-0,6	2903902	1
ELR H5-IES-SC- 24DC/500AC-2	2900414	1
ELR H5-IES-PT- 24DC/500AC-2	2903904	1
ELR H5-IES-SC-230AC/500AC-2	2900420	1
ELR H5-IES-SC- 24DC/500AC-9	2900421	1
ELR H5-IES-PT- 24DC/500AC-9	2903906	1
ELR H5-IES-SC-230AC/500AC-9	2900422	1

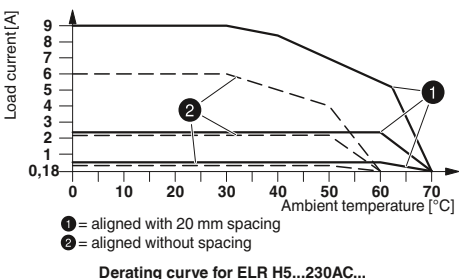
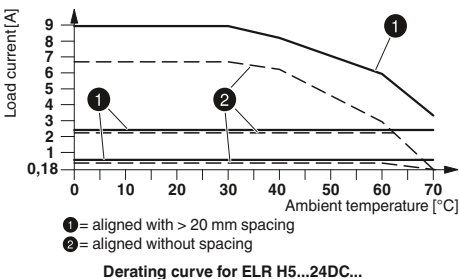



Motor protection



Reversing function only

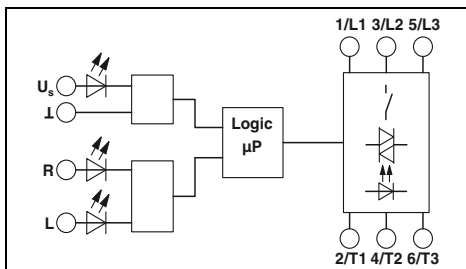
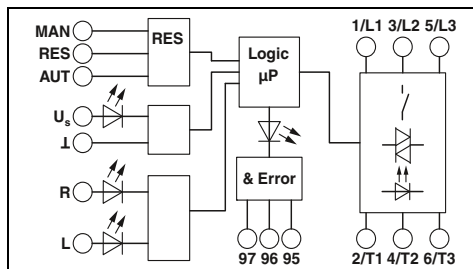

Technical data

24 V DC	230 V AC (50/60 Hz)
19.2 V DC ... 30 V DC	85 V AC ... 253 V AC
40 mA	4 mA
24 V DC	230 V AC
19.2 V DC ... 30 V DC	85 V AC ... 253 V AC
5 mA	7 mA
Reverse polarity protection , Surge protection	Surge protection

Green LED / Yellow LED / Red LED

42 V AC ... 550 V AC	42 V AC ... 550 V AC
Surge protection	

500 V
6 kV
-25 °C ... 70 °C (observe derating)
IEC 60947-1 / IEC 60947-4-2 / IEC 61508 / ISO 13849
vertical (horizontal DIN rail, motor output below)

alignable, for spacing see derating
0.2 - 2.5 mm² / 0.2 - 2.5 mm² / 24 - 14
22.5 mm / 99 mm / 114.5 mm

Ordering data

Type	Order No.	Pcs./ Pkt.
ELR H5-I-SC- 24DC/500AC-0,6	2900573	1
ELR H5-I-PT- 24DC/500AC-0,6	2903908	1
ELR H5-I-SC- 24DC/500AC-2	2900574	1
ELR H5-I-PT- 24DC/500AC-2	2903910	1
ELR H5-I-SC-230AC/500AC-2	2900575	1
ELR H5-I-SC- 24DC/500AC-9	2900576	1
ELR H5-I-PT- 24DC/500AC-9	2903912	1
ELR H5-I-SC-230AC/500AC-9	2900578	1

Technical data

24 V DC	230 V AC (50/60 Hz)
19.2 V DC ... 30 V DC	85 V AC ... 253 V AC
40 mA	4 mA
24 V DC	230 V AC
19.2 V DC ... 30 V DC	85 V AC ... 253 V AC
5 mA	7 mA
Reverse polarity protection , Surge protection	Surge protection

Green LED / Yellow LED / Red LED

42 V AC ... 550 V AC	42 V AC ... 550 V AC
Surge protection	

500 V
6 kV
-25 °C ... 70 °C (observe derating)
IEC 60947-1 / IEC 60947-4-2 / IEC 61508 / ISO 13849
vertical (horizontal DIN rail, motor output below)

alignable, for spacing see derating
0.2 - 2.5 mm² / 0.2 - 2.5 mm² / 24 - 14
22.5 mm / 99 mm / 114.5 mm

Ordering data

Type	Order No.	Pcs./ Pkt.
ELR H5-SC- 24DC/500AC-9	2900538	1
ELR H5-SC-230AC/500AC-9	2900539	1

Hybrid motor starters

Network-capable hybrid motor starter with direct start function

These 3-phase hybrid motor starters offer up to three functions: forward running, motor protection, and emergency stop up to SIL3 / PL e.

They offer the following advantages:

- Bus connection via Interface system (IFS) or via IO-Link
- Reduction in wiring
- Bi-metal function, adjustable up to 9 A
- Long service life
- Space-saving
- 3-phase loop bridging
- Safety level according to:
 - IEC 61508-1: SIL3
 - ISO 13849: PL e

Notes:
Type of housing: Polyamide PA, non-reinforced, color: green.
Marking systems and mounting material See Catalog 3



Motor protection, emergency stop, and Interface system support

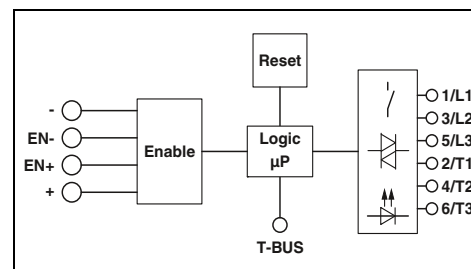

Technical data

Input data	
Rated control supply voltage U_s	24 V DC
Control supply voltage range	19.2 V DC ... 30 V DC
Rated control supply current I_c at U_s	60 mA
Rated actuating voltage U_c EN+	24 V DC
Actuating voltage range	19.2 V DC ... 30 V DC
Rated actuating current I_c at U_c	7 mA
Input circuit	Reverse polarity protection, Surge protection
Operating voltage / status / error indicator	Green LED / Yellow LED / Red LED
Output data load side	
Operating voltage range	42 V AC ... 550 V AC
Output protection	Surge protection
General data	
Rated insulation voltage	550 V
Rated surge voltage	6 kV
Ambient temperature (operation)	-5 °C ... 60 °C (observe derating)
Standards/regulations	IEC 60947-1 / EN 60947-4-2 / IEC 61508 / ISO 13849
Mounting position	vertical (horizontal DIN rail, motor output below)
Mounting	
Connection data solid/stranded/AWG	alignable, for spacing see derating
Dimensions	0.2 - 2.5 mm ² / 0.2 - 2.5 mm ² / 24 - 14 22.5 mm / 99 mm / 114.5 mm

Rated control supply voltage U_s	24 V DC
Control supply voltage range	19.2 V DC ... 30 V DC
Rated control supply current I_c at U_s	60 mA
Rated actuating voltage U_c EN+	24 V DC
Actuating voltage range	19.2 V DC ... 30 V DC
Rated actuating current I_c at U_c	7 mA
Input circuit	Reverse polarity protection, Surge protection
Operating voltage / status / error indicator	Green LED / Yellow LED / Red LED
Output data load side	
Operating voltage range	42 V AC ... 550 V AC
Output protection	Surge protection
General data	
Rated insulation voltage	550 V
Rated surge voltage	6 kV
Ambient temperature (operation)	-5 °C ... 60 °C (observe derating)
Standards/regulations	IEC 60947-1 / EN 60947-4-2 / IEC 61508 / ISO 13849
Mounting position	vertical (horizontal DIN rail, motor output below)
Mounting	
Connection data solid/stranded/AWG	alignable, for spacing see derating
Dimensions	0.2 - 2.5 mm ² / 0.2 - 2.5 mm ² / 24 - 14 22.5 mm / 99 mm / 114.5 mm

Ordering data

Description
Load current 0.075 A ... 0.6 A
Screw connection
Push-in connection
Load current 0.18 A ... 3 A
Screw connection
Push-in connection
Load current 1.5 A ... 9 A
Screw connection
Push-in connection

Type	Order No.	Pcs./Pkt.
ELR H3-IES-SC/500AC-06-IFS	2905154	1
ELR H3-IES-PT/500AC-06-IFS	2905141	1
ELR H3-IES-SC/500AC-3-IFS	2905155	1
ELR H3-IES-PT/500AC-3-IFS	2905142	1
ELR H3-IES-SC/500AC-9-IFS	2905156	1
ELR H3-IES-PT/500AC-9-IFS	2905143	1

Accessories

DIN rail connector

ME 22.5 TBUS 1,5/ 5-ST-3,81 GN	2707437	50
--------------------------------	---------	----

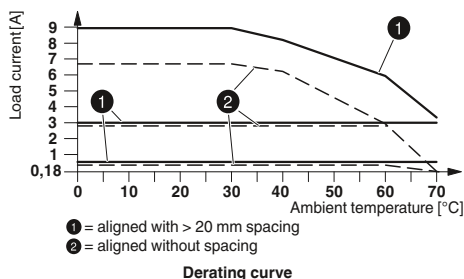



Motor protection and Interface system support



new

Motor protection, emergency stop, and IO-Link support

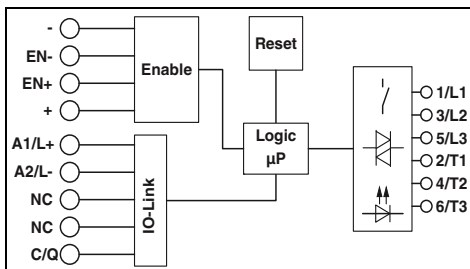
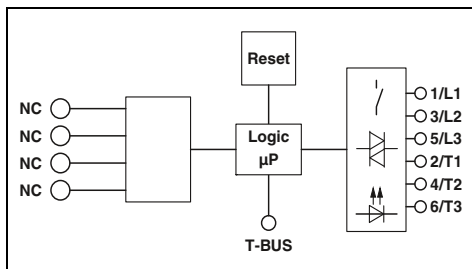

Technical data

Technical data

24 V DC
 19.2 V DC ... 30 V DC
 60 mA
 -
 -
 -
 Reverse polarity protection , Surge protection
 Green LED / Yellow LED / Red LED

42 V AC ... 550 V AC
 Surge protection

550 V
 6 kV
 -5 °C ... 60 °C (observe derating)
 IEC 60947-1 / EN 60947-4-2
 vertical (horizontal DIN rail, motor output below)

alignable, for spacing see derating
 0.2 - 2.5 mm² / 0.2 - 2.5 mm² / 24 - 14
 22.5 mm / 99 mm / 114.5 mm

24 V DC
 19.2 V DC ... 30 V DC
 65 mA
 24 V DC
 19.2 V DC ... 30 V DC
 7 mA
 Reverse polarity protection , Surge protection
 Green LED / Yellow LED / Red LED

42 V AC ... 550 V AC
 Surge protection

550 V
 6 kV
 -5 °C ... 55 °C (observe derating)
 IEC 60947-1 / EN 60947-4-2 / IEC 61508 / ISO 13849
 vertical (horizontal DIN rail, motor output below)

alignable, for spacing see derating
 0.2 - 2.5 mm² / 0.2 - 2.5 mm² / 24 - 14
 22.5 mm / 99 mm / 114.5 mm

Ordering data

Ordering data

Type	Order No.	Pcs./ Pkt.
ELR H3-I-SC/500AC-06-IFS	2905162	1
ELR H3-I-PT/500AC-06-IFS	2905148	1
ELR H3-I-SC/500AC-3-IFS	2905163	1
ELR H3-I-PT/500AC-3-IFS	2905149	1
ELR H3-I-SC/500AC-9-IFS	2905164	1
ELR H3-I-PT/500AC-9-IFS	2905150	1

Type	Order No.	Pcs./ Pkt.
ELR H3-IES-PT/500AC-3-IOL	2908671	1
ELR H3-IES-PT/500AC-9-IOL	2908672	1

Accessories

Accessories

ME 22,5 TBUS 1,5/ 5-ST-3,81 GN	2707437	50
--------------------------------	---------	----

--	--	--

Hybrid motor starters

Network-capable hybrid motor starter with direct start function

These 3-phase hybrid motor starters offer up to three functions: forward running, motor protection, and emergency stop up to SIL3 / PL e.

They offer the following advantages:

- Connection to SmartWire-DT™ (SWD)
- 22.5 mm wide
- Reduction in wiring
- Bi-metal function, adjustable up to 9 A
- Long service life
- Space-saving
- 3-phase loop bridging

Safety level according to:

- IEC 61508-1: SIL3
- ISO 13849: PL e



Motor protection, emergency stop, and SmartWire-DT™ support

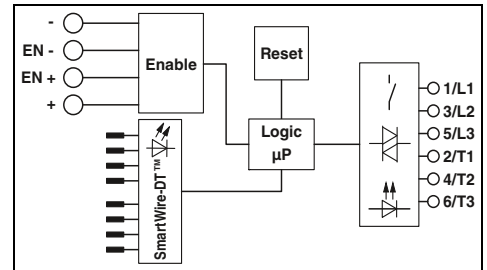

Technical data

Input data	
Rated supply voltage U_s	24 V DC
Control supply voltage range	19.2 V DC ... 30 V DC
Rated control supply current I_c at U_s	60 mA
Rated actuating voltage U_c EN+	24 V DC
Actuating voltage range	19.2 V DC ... 30 V DC
Rated actuating current I_c at U_c	7 mA
Input circuit	Reverse polarity protection, Surge protection
Operating voltage / status / error indicator	Green LED / Yellow LED / Red LED
Output data load side	
Operating voltage range	42 V AC ... 550 V AC
Output protection	Surge protection
General data	
Rated insulation voltage	550 V
Rated surge voltage	6 kV
Ambient temperature (operation)	-5 °C ... 55 °C (observe derating)
Standards/regulations	IEC 60947-1 / EN 60947-4-2 / IEC 61508 / ISO 13849
Mounting position	vertical (horizontal DIN rail, motor output below)
Mounting	alignable, for spacing see derating
Connection data solid/stranded/AWG	0.2 - 2.5 mm ² / 0.2 - 2.5 mm ² / 24 - 14
Dimensions	22.5 mm / 99 mm / 114.5 mm

Ordering data

Description	Type	Order No.	Pcs./Pkt.
Load current 0.075 A ... 0.6 A Push-in connection	ELR H3-IES-PT-SWD/500AC-06	2903936	1
Load current 0.18 A ... 2.4 A Push-in connection	ELR H3-IES-PT-SWD/500AC-3	2903937	1
Load current 1.5 A ... 9 A Push-in connection	ELR H3-IES-PT-SWD/500AC-9	2903938	1

Accessories

Device plug, 8-pos.	SWD4-8SF2-5 PXC	2903107	10
---------------------	-----------------	---------	----

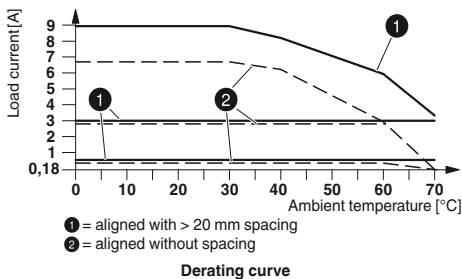



Motor protection and SmartWire-DT™ support

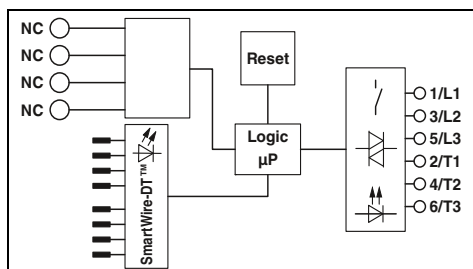

Technical data

24 V DC
19.2 V DC ... 30 V DC
60 mA

-
-
Reverse polarity protection , Surge protection
Green LED / Yellow LED / Red LED

42 V AC ... 550 V AC
Surge protection

550 V
6 kV
-5 °C ... 55 °C (observe derating)
IEC 60947-1 / EN 60947-4-2
vertical (horizontal DIN rail, motor output below)

alignable, for spacing see derating
0.2 - 2.5 mm² / 0.2 - 2.5 mm² / 24 - 14
22.5 mm / 99 mm / 114.5 mm

Ordering data

Type	Order No.	Pcs./ Pkt.
ELR H3-I-PT-SWD/500AC-06	2905076	1
ELR H3-I-PT-SWD/500AC-3	2905078	1
ELR H3-I-PT-SWD/500AC-9	2905079	1

Accessories

SWD4-8SF2-5 PXC	2903107	10
-----------------	---------	----

Hybrid motor starters

Hybrid motor starters with direct start function

These 3-phase hybrid motor starters offer up to three functions: forward running, motor protection, and emergency stop up to SIL3 / PL e.

They offer the following advantages:

- 22.5 mm wide
- Reduction in wiring
- Bi-metal function, adjustable up to 9 A
- Long service life
- Space-saving
- 3-phase loop bridging
- Safety level according to:
 - IEC 61508-1: SIL3
 - ISO 13849: PL e

Notes:
Type of housing: Polyamide PA, non-reinforced, color: green.
Marking systems and mounting material See Catalog 3



Motor protection and emergency stop

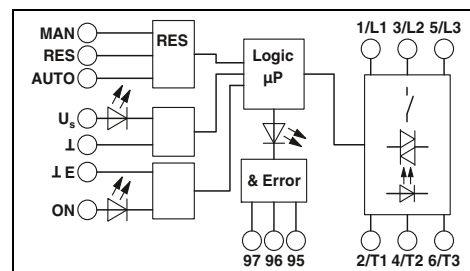

Technical data

Input data	
Rated control supply voltage U_s	24 V DC
Control supply voltage range	19.2 V DC ... 30 V DC
Rated control supply current I_s at U_s	40 mA
Rated actuation voltage U_c ON	24 V DC
Actuating voltage range	19.2 V DC ... 30 V DC
Rated actuating current I_c at U_c	5 mA
Input circuit	
Operating voltage / status / error indicator	Green LED / Yellow LED / Red LED
Output data load side	
Operating voltage range	42 V AC ... 550 V AC
Output protection	42 V AC ... 550 V AC
General data	
Rated insulation voltage	500 V
Rated surge voltage	6 kV
Ambient temperature (operation)	-25 °C ... 70 °C (observe derating)
Standards/regulations	IEC 60947-1 / IEC 60947-4-2 / IEC 61508 / ISO 13849
Mounting position	vertical (horizontal DIN rail, motor output below)
Mounting	alignable, for spacing see derating
Connection data solid/stranded/AWG	0.2 - 2.5 mm ² / 0.2 - 2.5 mm ² / 24 - 14
Dimensions	22.5 mm / 99 mm / 114.5 mm

Rated control supply voltage U_s	230 V AC (50/60 Hz)
Control supply voltage range	85 V AC ... 253 V AC
Rated control supply current I_s at U_s	4 mA
Rated actuation voltage U_c ON	230 V AC
Actuating voltage range	85 V AC ... 253 V AC
Rated actuating current I_c at U_c	7 mA
Input circuit	Reverse polarity protection , Surge protection
Operating voltage / status / error indicator	Green LED / Yellow LED / Red LED
Output data load side	
Operating voltage range	42 V AC ... 550 V AC
Output protection	42 V AC ... 550 V AC
General data	
Rated insulation voltage	500 V
Rated surge voltage	6 kV
Ambient temperature (operation)	-25 °C ... 70 °C (observe derating)
Standards/regulations	IEC 60947-1 / IEC 60947-4-2 / IEC 61508 / ISO 13849
Mounting position	vertical (horizontal DIN rail, motor output below)
Mounting	alignable, for spacing see derating
Connection data solid/stranded/AWG	0.2 - 2.5 mm ² / 0.2 - 2.5 mm ² / 24 - 14
Dimensions	22.5 mm / 99 mm / 114.5 mm

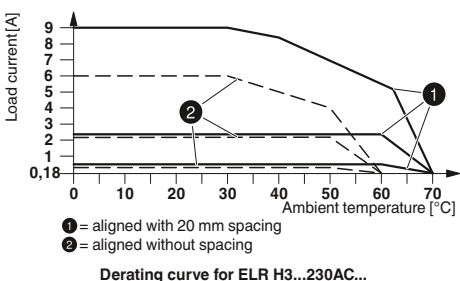
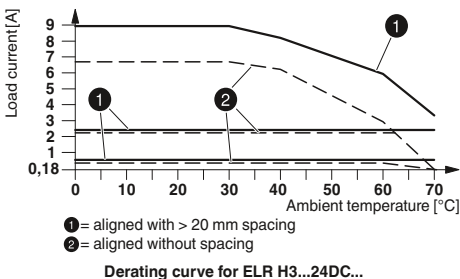

Description
Load current 0.075 A ... 0.6 A
Screw connection
Push-in connection
Load current 0.18 A ... 2.4 A
Screw connection
Push-in connection
Screw connection
Load current 1.5 A ... 9 A
Screw connection
Push-in connection
Screw connection
Load current 0 A ... 9 A
Screw connection
Screw connection

Ordering data		
Type	Order No.	Pcs./ Pkt.
ELR H3-IES-SC- 24DC/500AC-0,6	2900566	1
ELR H3-IES-PT- 24DC/500AC-0,6	2903914	1
ELR H3-IES-SC- 24DC/500AC-2	2900567	1
ELR H3-IES-PT- 24DC/500AC-2	2903916	1
ELR H3-IES-SC-230AC/500AC-2	2900568	1
ELR H3-IES-SC- 24DC/500AC-9	2900569	1
ELR H3-IES-PT- 24DC/500AC-9	2903918	1
ELR H3-IES-SC-230AC/500AC-9	2900570	1



Motor protection



Direct start function only

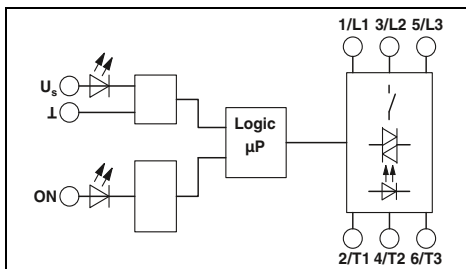
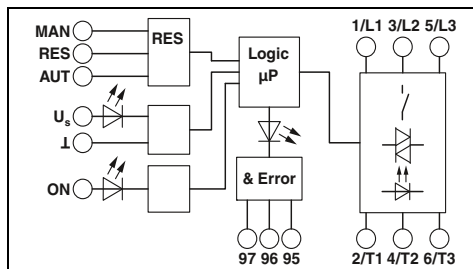

Technical data

24 V DC	230 V AC (50/60 Hz)
19.2 V DC ... 30 V DC	85 V AC ... 253 V AC
40 mA	4 mA
24 V DC	230 V AC
19.2 V DC ... 30 V DC	85 V AC ... 253 V AC
5 mA	7 mA
Reverse polarity protection , Surge protection	Surge protection

Green LED / Yellow LED / Red LED

42 V AC ... 550 V AC	42 V AC ... 550 V AC
Surge protection	

500 V
6 kV
-25 °C ... 70 °C (observe derating)
IEC 60947-1 / IEC 60947-4-2 / IEC 61508 / ISO 13849
vertical (horizontal DIN rail, motor output below)

alignable, for spacing see derating
0.2 - 2.5 mm² / 0.2 - 2.5 mm² / 24 - 14
22.5 mm / 99 mm / 114.5 mm

Technical data

24 V DC	230 V AC (50/60 Hz)
19.2 V DC ... 30 V DC	85 V AC ... 253 V AC
40 mA	4 mA
24 V DC	230 V AC
19.2 V DC ... 30 V DC	85 V AC ... 253 V AC
5 mA	7 mA
Reverse polarity protection , Surge protection	Surge protection

Green LED / Yellow LED / Red LED

42 V AC ... 550 V AC	42 V AC ... 550 V AC
Surge protection	

500 V
6 kV
-25 °C ... 70 °C (observe derating)
IEC 60947-1 / IEC 60947-4-2 / IEC 61508 / ISO 13849
vertical (horizontal DIN rail, motor output below)

alignable, for spacing see derating
0.2 - 2.5 mm² / 0.2 - 2.5 mm² / 24 - 14
22.5 mm / 99 mm / 114.5 mm

Ordering data

Type	Order No.	Pcs./ Pkt.
ELR H3-I-SC- 24DC/500AC-0,6	2900542	1
ELR H3-I-PT- 24DC/500AC-0,6	2903920	1
ELR H3-I-SC- 24DC/500AC-2	2900543	1
ELR H3-I-PT- 24DC/500AC-2	2903922	1
ELR H3-I-SC-230AC/500AC-2	2900544	1
ELR H3-I-SC- 24DC/500AC-9	2900545	1
ELR H3-I-PT- 24DC/500AC-9	2903924	1
ELR H3-I-SC-230AC/500AC-9	2900546	1

Ordering data

Type	Order No.	Pcs./ Pkt.
ELR H3-SC- 24DC/500AC-9	2900530	1
ELR H3-SC-230AC/500AC-9	2900531	1

Hybrid motor starters

Hybrid motor starters with short-circuit protection



These short-circuit-proof 3-phase hybrid motor starters for mounting on 35 mm DIN rails or 60 mm power busbars combine four functions in one device: forward running, reverse running, motor protection, and emergency stop up to SIL3 / PL e.

- They offer the following advantages:
- 22.5 mm wide
 - Bi-metal function can be set up to 9 A
 - Long service life
 - Space-saving
 - Reduction in wiring
 - 3-phase loop bridging
 - Plug-in motor output terminal block
 - Coordination type 2 according to IEC/EN 60947-4-2
 - IEC 61508-1: SIL3
 - ISO 13849: PL e

Input data

Rated control supply voltage U_s
 Control supply voltage range
 Rated control supply current I_s at U_s
 Rated actuating voltage U_c R/L
 Actuating voltage range
 Rated actuating current I_c at U_c
 Input circuit

Operating voltage / status / error indicator
 Output data load side
 Operating voltage range
 Load current range

Output protection

General data

Rated insulation voltage
 Rated surge voltage
 Ambient temperature (operation)
 Standards/regulations
 Mounting position

Mounting

Screw connection solid/stranded/AWG

Dimensions

W / H / D

Description

Short-circuit-proof hybrid motor starter

Hybrid motor starter
 DIN rail adapter
 Busbar adapter, 160 mm
 Busbar adapter, 200 mm

Set consisting of short-circuit-proof hybrid motor starter and adapter

- with DIN rail adapter
- with busbar adapter, 160 mm
- with busbar adapter, 200 mm

Fuse

Coordination type 2 to 10 kA/500 V
 Coordination type 2 to 5 kA/400 V
 Coordination type 1 to 30 kA/500 V



For reversing 3~ AC motors up to 550 V AC/3 x 0.6 A



For reversing 3~ AC motors up to 550 V AC/3 x 2.4 A



For reversing 3~ AC motors up to 550 V AC/3 x 9 A

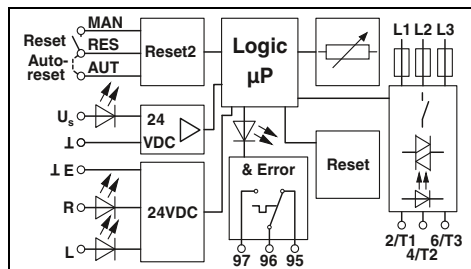
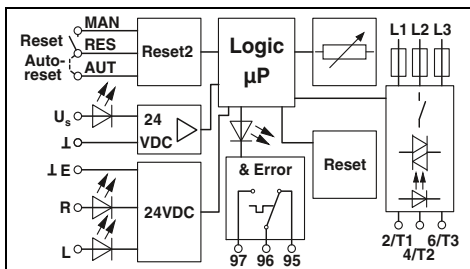
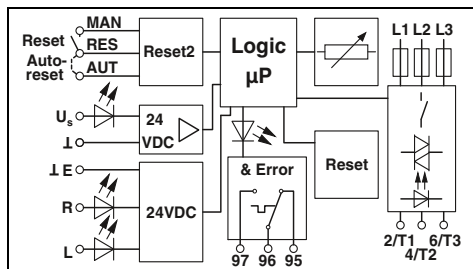

Technical data

24 V DC
19.2 V DC ... 30 V DC
40 mA
24 V DC
19.2 V DC ... 30 V DC
5 mA
Reverse polarity protection, Surge protection
Green LED / Yellow LED / Red LED

42 V AC ... 550 V AC
75 mA ... 600 mA (see derating)

Surge protection, Short-circuit protection

500 V
6 kV
-25 °C ... 70 °C (observe derating)
IEC 60947-1 / EN 60947-4-2 / IEC 61508 / ISO 13849
vertical (horizontal DIN rail, motor output below)

alignable, for spacing see derating
0.2 - 2.5 mm² / 0.2 - 2.5 mm² / 24 - 14
22.5 mm / 160 mm / 114.5 mm

Technical data

24 V DC
19.2 V DC ... 30 V DC
40 mA
24 V DC
19.2 V DC ... 30 V DC
5 mA
Reverse polarity protection, Surge protection
Green LED / Yellow LED / Red LED

42 V AC ... 550 V AC
180 mA ... 2.4 A (see derating)

Surge protection, Short-circuit protection

500 V
6 kV
-25 °C ... 70 °C (observe derating)
IEC 60947-1 / EN 60947-4-2 / IEC 61508 / ISO 13849
vertical (horizontal DIN rail, motor output below)

alignable, for spacing see derating
0.2 - 2.5 mm² / 0.2 - 2.5 mm² / 24 - 14
22.5 mm / 160 mm / 114.5 mm

Technical data

24 V DC
19.2 V DC ... 30 V DC
40 mA
24 V DC
19.2 V DC ... 30 V DC
5 mA
Reverse polarity protection, Surge protection
Green LED / Yellow LED / Red LED

42 V AC ... 550 V AC
1.5 A ... 9 A (see derating)

Surge protection, Short-circuit protection

500 V
6 kV
-25 °C ... 70 °C (observe derating)
IEC 60947-1 / EN 60947-4-2 / IEC 61508 / ISO 13849
vertical (horizontal DIN rail, motor output below)

alignable, for spacing see derating
0.2 - 2.5 mm² / 0.2 - 2.5 mm² / 24 - 14
22.5 mm / 160 mm / 114.5 mm

Ordering data

Type	Order No.	Pcs./ Pkt.
ELR H51-IESSC-24DC500AC-06	2902746	1
EM RD-ADAPTER	2902747	1
EM RI-ADAPTER COMPACT	2902748	1
EM RI-ADAPTER CLASSIC	2902831	1
ELR H51-0.6-DIN-RAIL-SET	2902952	1
ELR-H51-0,6-BUSBAR-COMPACT-SET	2904333	1
ELR-H51-0,6-BUSBAR-CLASSIC-SET	2904334	1

Ordering data

Type	Order No.	Pcs./ Pkt.
ELR H51-IESSC-24DC500AC-2	2902744	1
EM RD-ADAPTER	2902747	1
EM RI-ADAPTER COMPACT	2902748	1
EM RI-ADAPTER CLASSIC	2902831	1
ELR H51-2.4-DIN-RAIL-SET	2902953	1
ELR-H51-2,4-BUSBAR-COMPACT-SET	2904335	1
ELR-H51-2,4-BUSBAR-CLASSIC-SET	2904336	1

Ordering data

Type	Order No.	Pcs./ Pkt.
ELR H51-IESSC-24DC500AC-9	2902745	1
EM RD-ADAPTER	2902747	1
EM RI-ADAPTER COMPACT	2902748	1
EM RI-ADAPTER CLASSIC	2902831	1
ELR H51-9-DIN-RAIL-SET	2902954	1
ELR-H51-9-BUSBAR-COMPACT-SET	2904337	1
ELR-H51-9-BUSBAR-CLASSIC-SET	2904338	1

Accessories

FUSE-10X38-16A-GR	2903126	10
FUSE-10X38-20A-GR	2903384	10
FUSE-10X38-30A-MR	2903119	10

Accessories

FUSE-10X38-16A-GR	2903126	10
FUSE-10X38-20A-GR	2903384	10
FUSE-10X38-30A-MR	2903119	10

Accessories

FUSE-10X38-16A-GR	2903126	10
FUSE-10X38-20A-GR	2903384	10
FUSE-10X38-30A-MR	2903119	10

Hybrid motor starters

Continuous bridge for hybrid motor starters

The flexible CONTACTRON loop bridge (BRIDGE-...) simplifies the supply and looping through of phases L1, L2, and L3. It is available in 2 to 10-way versions for modules in the CONTACTRON family with 22.5 mm housing width.

Features of the 3-phase loop bridge:

- Considerable reduction in wiring
- Suitable for CONTACTRON series
 - ELR H3...
 - ELR H5...
 - ELR (W)3...
 - EMM...IFS
- Bridging of 2 to 10 devices with maximum module spacing of 22.5 mm
- Up to 575 V AC/3 x 25 A
- Additional bridge versions available on request



0.3 m connecting cable for hybrid motor starter with screw connection

ERC

General data	
Nominal voltage U_N	42 V AC ... 575 V AC
Nominal current at U_N	≤ 25 A
Cross section	2.5 mm ²

Technical data		
42 V AC ... 575 V AC		
≤ 25 A		
2.5 mm ²		

Description	
3-phase loop bridge	
2-way	
3-way	
4-way	
5-way	
6-way	
7-way	
8-way	
9-way	
10-way	

Ordering data			
Type	Order No.	Pcs./Pkt.	
BRIDGE- 2	2900746	1	
BRIDGE- 3	2900747	1	
BRIDGE- 4	2900748	1	
BRIDGE- 5	2900749	1	
BRIDGE- 6	2900750	1	
BRIDGE- 7	2900751	1	
BRIDGE- 8	2900752	1	
BRIDGE- 9	2900753	1	
BRIDGE-10	2900754	1	

Covering hood for unused connectors	

Accessories		
BRIDGE COVER	2906240	10

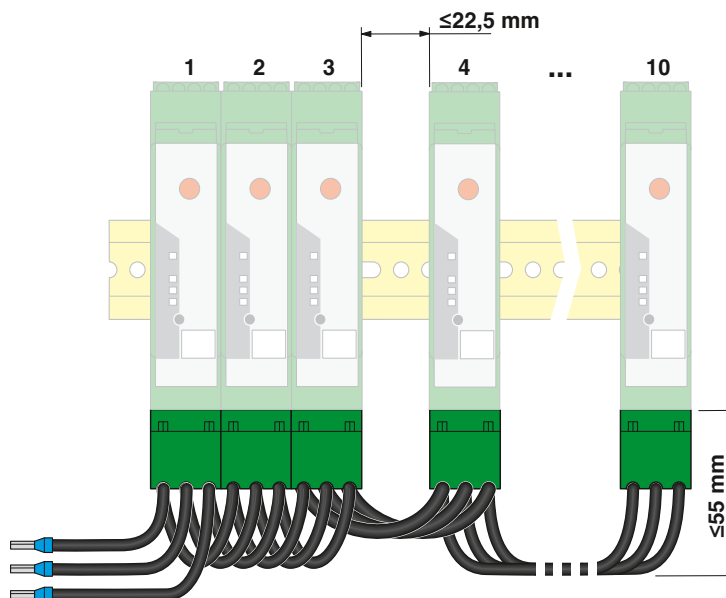



3 m connecting cable for hybrid motor starter with screw connection



3 m connecting cable for hybrid motor starter with Push-in connection

ERC

ERC

Technical data
42 V AC ... 575 V AC
≤ 25 A
2.5 mm ²

Technical data
42 V AC ... 575 V AC
≤ 25 A
2.5 mm ²

Ordering data		
Type	Order No.	Pcs./Pkt.
BRIDGE- 2-3M	2901543	1
BRIDGE- 3-3M	2901656	1
BRIDGE- 4-3M	2901659	1
BRIDGE- 5-3M	2901545	1
BRIDGE- 6-3M	2901697	1
BRIDGE- 7-3M	2901698	1
BRIDGE- 8-3M	2901700	1
BRIDGE- 9-3M	2901701	1
BRIDGE-10-3M	2901702	1

Ordering data		
Type	Order No.	Pcs./Pkt.
BRIDGE-PT 2	2904490	1
BRIDGE-PT 3	2904491	1
BRIDGE-PT 4	2904492	1
BRIDGE-PT 5	2904493	1
BRIDGE-PT 6	2904494	1
BRIDGE-PT 7	2904495	1
BRIDGE-PT 8	2904496	1
BRIDGE-PT 9	2904497	1
BRIDGE-PT 10	2904498	1

Accessories		
Type	Order No.	Pcs./Pkt.
BRIDGE COVER	2906240	10

Accessories		
Type	Order No.	Pcs./Pkt.
BRIDGE COVER	2906240	10

Hybrid motor starters

SmartWire-DT™ accessories

Devices are integrated seamlessly into the fieldbus world via SmartWire-DT™ with the SmartWire-DT™ “EM SWD-ADAPTER” adapter for CONTACTRON 24 V DC devices. Corresponding gateways are available for the following bus systems:

- PROFIBUS DP
- CANopen®
- Modbus/TCP / EtherNet/IP™



SmartWire-DT™ adapter



Technical data			
Input data			
Supply voltage U_{AUX}	-		
Rated current I_{AUX}	-		
Supply voltage U_{POW}	-		
Rated current I_{POW}	-		
Input data			
Description	Enable input		
Input voltage	24 V DC		
Input current	5 mA		
Output data			
Description	-		
Output supply	-		
Output current	-		
SmartWire-DT interface			
Connection method	Pin strip, 8-pos.		
Data rate	125 kBd / 250 kBd		
Current consumption I_{AUX}	120 mA		
Current consumption I_{POW}	25 mA		
General data			
Ambient temperature (operation)	-25 °C ... 55 °C		
Standards/regulations	IEC 60947-1 / EN 60947-1		
Degree of protection in acc. with IEC 60529/EN 60529	IP20		
Mounting position	any		
Mounting	On CONTACTRON hybrid motor starter		
Connection data solid/stranded/AWG	0.14 - 1 mm ² / 0.14 - 1 mm ² / 26 - 18		
Dimensions	22.5 mm / 165 mm / 114.5 mm		
	W / H / D		
Ordering data			
Description	Type	Order No.	Pcs./ Pkt.
SmartWire-DT™ adapter			
Gateways			
CANopen®			
PROFIBUS			
Ethernet			
I/O modules			
Digital, 4 inputs, 4 outputs			
Digital, 4 inputs			
Digital, 8 outputs			
Analog, 2 inputs, 2 outputs			
Power feed module for supplying further SmartWire-DT™ devices			
		2902776	1



Gateways



I/O modules



Power feed

Technical data	
24 V DC -15 % ... +20 %	-
3 A	-
24 V DC -15 % ... +20 %	-
700 mA	-
-	-
-	-
-	-
-	-
Pin strip, 8-pos. 125 kBd / 250 kBd	Pin strip, 8-pos. 125 kBd / 250 kBd
-	-
-	-
-25 °C ... 55 °C	-25 °C ... 55 °C
EN 50178	EN 50178
IP20	IP20
any	any
-	-
0.2 - 1.5 mm ² / 0.2 - 1.5 mm ² / 24 - 16	0.2 - 1.5 mm ² / 0.2 - 1.5 mm ² / 24 - 16
35 mm / 90 mm / 127 mm	35 mm / 90 mm / 101 mm

Technical data	
-	-
-	-
-	-
-	-
Digital inputs 24 V DC typ. 4 mA	Analog inputs -
-	-
Digital outputs 24 V DC -15 % ... +20 % typ. 500 mA	Analog outputs -
-	-
Pin strip, 8-pos. 125 kBd / 250 kBd	Pin strip, 8-pos. 125 kBd / 250 kBd
-	-
-	-
-25 °C ... 55 °C	-25 °C ... 55 °C
EN 50178	EN 50178
IP20	IP20
any	any
-	-
0.2 - 1.5 mm ² / 0.2 - 1.5 mm ² / 24 - 16	0.2 - 1.5 mm ² / 0.2 - 1.5 mm ² / 24 - 16
35 mm / 90 mm / 101 mm	

Technical data	
24 V DC -15 % ... +20 %	-
3 A	-
24 V DC -15 % ... +20 %	-
700 mA	-
-	-
-	-
-	-
-	-
Pin strip, 8-pos. 125 kBd / 250 kBd	Pin strip, 8-pos. 125 kBd / 250 kBd
-	-
-	-
-25 °C ... 55 °C	-25 °C ... 55 °C
EN 50178	EN 50178
IP20	IP20
any	any
-	-
0.2 - 1.5 mm ² / 0.2 - 1.5 mm ² / 24 - 16	0.2 - 1.5 mm ² / 0.2 - 1.5 mm ² / 24 - 16
35 mm / 90 mm / 124 mm	

Ordering data		
Type	Order No.	Pcs./ Pkt.
EU5C-SWD-CAN PXC	2903098	1
EU5C-SWD-DP PXC	2903100	1
EU5C-SWD-EIP-MODTCP PXC	2903244	1

Ordering data		
Type	Order No.	Pcs./ Pkt.
EU5E-SWD-4D4D PXC	2903101	1
EU5E-SWD-4DX PXC	2903102	1
EU5E-SWD-X8D PXC	2903103	1
EU5E-SWD-2A2A PXC	2903104	1

Ordering data		
Type	Order No.	Pcs./ Pkt.
EU5C-SWD-PF2-1 PXC	2903113	1

Hybrid motor starters

SmartWire-DT™ accessories



Plug tools



Flat-ribbon cable, 8-pos.

		Ordering data			Ordering data		
Description	Color	Type	Order No.	Pcs./ Pkt.	Type	Order No.	Pcs./ Pkt.
Pliers for device plugs		SWD4-CRP-1 PXC	2903110	1			
Pliers for flat plugs		SWD4-CRP-2 PXC	2903114	1			
Flat-ribbon cable, 8-pos., 100 m					SWD4-100LF-8-24 PXC	2903111	1
Flat-ribbon cable, assembled with 2 flat plugs, 8-pos., 3 m					SWD4-3LF8-24-2S PXC	2903112	1

SmartWire-DT™ accessories

Accessories for SmartWire-DT™ and SmartWire-DT™ devices for connecting digital and analog input and output signals.



Plug and coupling



Programming adapter

		Ordering data			Ordering data		
Description	Color	Type	Order No.	Pcs./ Pkt.	Type	Order No.	Pcs./ Pkt.
Plug and coupling							
Network dummy plug		SWD4-RC8-10 PXC	2903106	1			
Device plug, 8-pos.		SWD4-8SF2-5 PXC	2903107	10			
Flat plug, 8-pos.		SWD4-8MF2 PXC	2903108	10			
Coupling for 8-pos. flat plug		SWD4-8SFF2-5 PXC	2903109	1			
Programming adapter					EU4A-RJ45-USB-CAB1 PXC	2903465	1

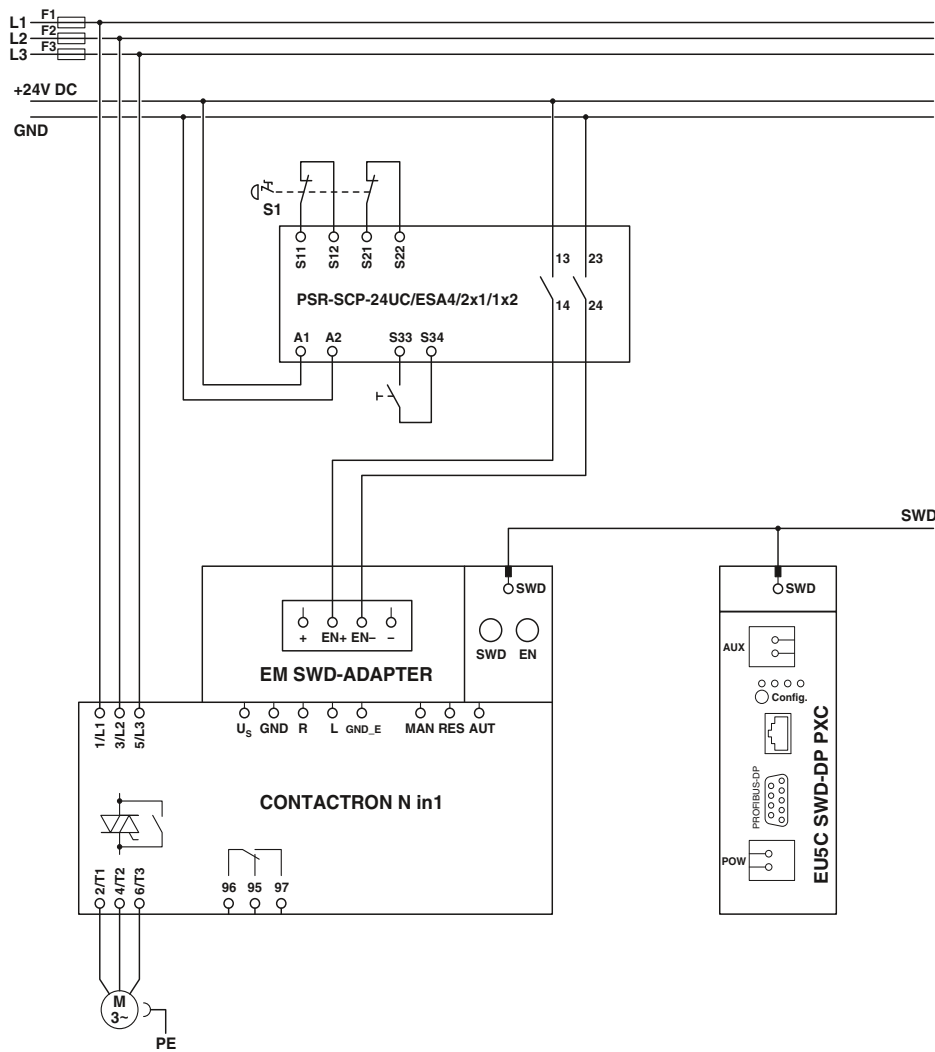

Emergency stop wiring example (two-channel)

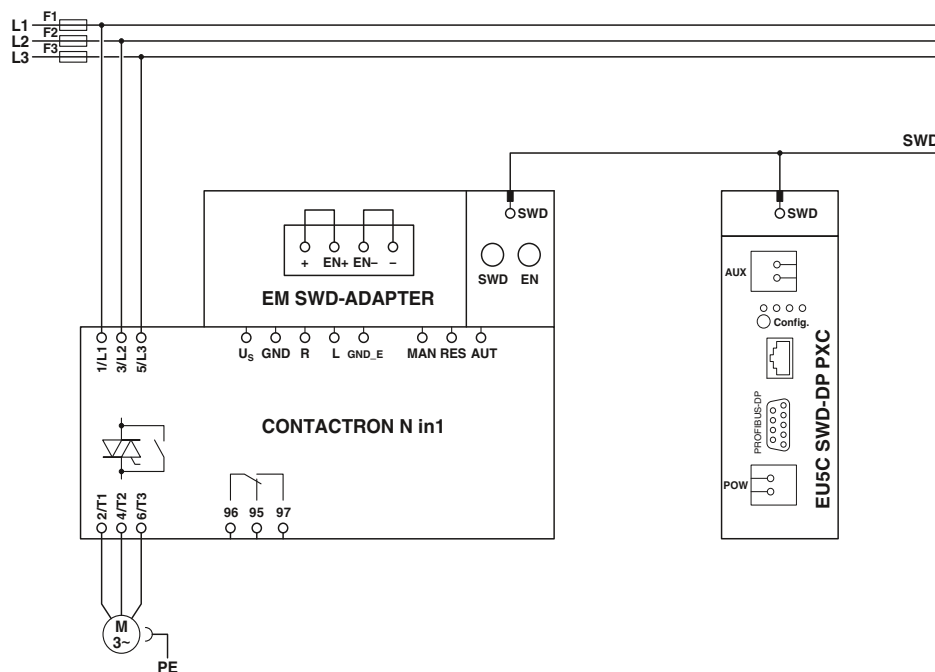

Wiring example without emergency stop

Intended use

The SmartWire-DT™ adapter is approved exclusively for use in conjunction with the following CONTACTRON hybrid motor starters. If other switching devices are used, correct operation, in particular of the safety function, cannot be ensured.

Motor protection and safe shutdown

2900582	ELR H5-IES-SC-24DC/500AC-0,6
2900414	ELR H5-IES-SC-24DC/500AC-2
2900421	ELR H5-IES-SC-24DC/500AC-9
2900566	ELR H3-IES-SC-24DC/500AC-0,6
2900567	ELR H3-IES-SC-24DC/500AC-2
2900569	ELR H3-IES-SC-24DC/500AC-9
2297031	ELR W3- 24DC/500AC-2I
2297057	ELR W3- 24DC/500AC-9I
2902952	ELR H51-0,6-DINRAIL-SET
2902953	ELR H51-2,4-DINRAIL-SET
2902954	ELR H51-9-DINRAIL-SET
2902746	ELR H51-IESSC-24DC500AC-06
2902744	ELR H51-IESSC-24DC500AC-2
2902745	ELR H51-IESSC-24DC500AC-9

Motor protection only

2900573	ELR H5-I-SC-24DC/500AC-0,6
2900574	ELR H5-I-SC-24DC/500AC-2
2900576	ELR H5-I-SC-24DC/500AC-9
2900542	ELR H3-I-SC-24DC/500AC-0,6
2900543	ELR H3-I-SC-24DC/500AC-2
2900545	ELR H3-I-SC-24DC/500AC-9

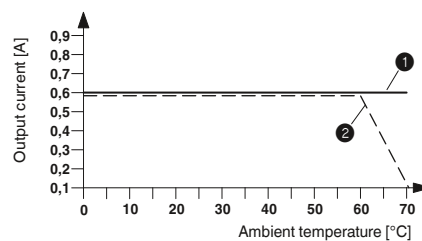

ELR H5-IES-SC-SWD/500AC-0,6 derating curve
100% operating time

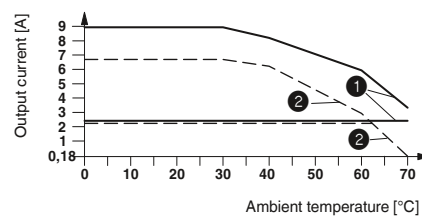

ELR H5-IES-SC-SWD/500AC-2 and
ELR H5-IES-SC-SWD/500AC-9 derating curve
100% operating time

- ① Aligned with > 20 mm spacing
- ② Aligned without spacing

Solid-state contactors

3-phase solid-state reversing contactors

The 3-phase solid-state reversing contactors with integrated locking circuit and load wiring are the ideal match for applications such as:

- Control valves
- Slides
- Switches
- Ship steering gear

The power spectrum ranges from 575 V AC/3 x 2 A to 575 V AC/3 x 37 A. This corresponds to 1 kW to 18.5 kW.

Advantages of 3-phase solid-state reversing contactor:

- Noise-free and wear-free switching
- Integrated protective circuit
- Stable and short switching times
- Long service life
- High switching frequency
- Integrated locking and load wiring
- Thermal fuse optional

Notes:
Type of insulation housing: ELR W 3...2, ELR W 3...9 Polyamide PA, non-reinforced, color: green
ELR W 3...16, ELR W 3...37 Polyester PBT, non-reinforced, color: green
Marking systems and mounting material See Catalog 3



For reversing 3~ AC motors up to 575 V AC/3 x 2 A

® EAC DNV GL

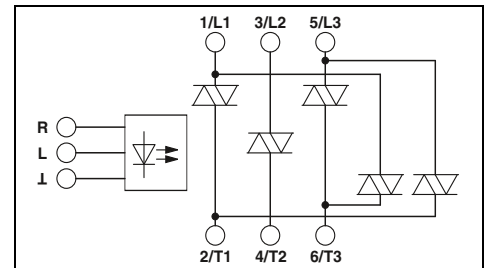

Technical data

Input data	
Rated actuating voltage U_c R/L	24 V DC
Actuating voltage range	19.2 V DC ... 30 V DC
Rated actuating current I_c at U_c	12.7 mA
Input circuit	Reverse polarity protection, Surge protection
Operating voltage / status / error indicator	- / Yellow LED / Red LED
Output data load side	
Operating voltage range	48 V AC ... 575 V AC
Periodic peak reverse voltage	1200 V
Load current range	100 mA ... 2 A (see derating)
Residual voltage	< 1.5 V
Leakage current	6 mA
Max. load value $I^2 \times t$ (t = 10 ms)	250 A ² s
Output protection	RCV circuit
General data	
Rated insulation voltage	500 V
Rated surge voltage	6 kV
Insulation	Basic insulation
Reversing frequency	≤ 10 Hz
Switching frequency	max. 5 Hz
Ambient temperature (operation)	-25 °C ... 70 °C
Standards/regulations	DIN EN 50178 / EN 60947
Degree of protection in acc. with IEC 60529/EN 60529	IP20
Mounting position	Vertical (horizontal DIN rail)
Mounting	Can be aligned with spacing = 20 mm
Screw connection solid/stranded/AWG	0.2 - 2.5 mm ² / 0.2 - 2.5 mm ² / 24 - 14
- Control side	0.2 - 2.5 mm ² / 0.2 - 2.5 mm ² / 24 - 14
- Load side	40 mm / 99 mm / 114.5 mm
Dimensions	W / H / D

230 V AC	92 V AC ... 253 V AC
11.2 mA	11.2 mA
48 V AC ... 575 V AC	48 V AC ... 575 V AC
1200 V	1200 V
100 mA ... 2 A (see derating)	100 mA ... 2 A (see derating)
< 1.5 V	< 1.5 V
6 mA	6 mA
250 A ² s	250 A ² s
RCV circuit	
6 kV	6 kV
Basic insulation	Basic insulation
≤ 10 Hz	≤ 2 Hz
max. 5 Hz	max. 1 Hz
-25 °C ... 70 °C	
DIN EN 50178 / EN 60947	
IP20	
Vertical (horizontal DIN rail)	
Can be aligned with spacing = 20 mm	
0.2 - 2.5 mm ² / 0.2 - 2.5 mm ² / 24 - 14	
0.2 - 2.5 mm ² / 0.2 - 2.5 mm ² / 24 - 14	
40 mm / 99 mm / 114.5 mm	

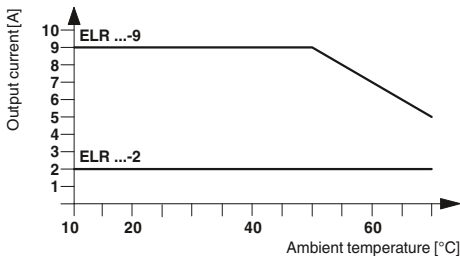

Load current as a function of the ambient temperature
Operating time: 100% operating factor

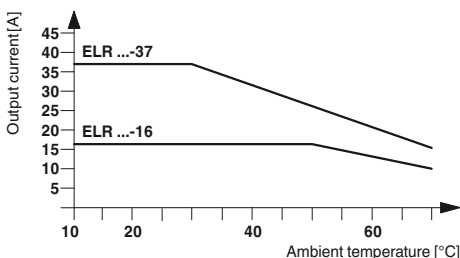

Load current as a function of the ambient temperature
Operating time: 100% operating factor

Description	3-phase solid-state reversing contactor
-------------	---

Thermal fuse	
--------------	--

Ordering data		
Type	Order No.	Pcs./ Pkt.
ELR W3- 24DC/500AC- 2	2297293	1
ELR W3-230AC/500AC- 2	2297303	1

Accessories		
THERMAL FUSE TF104	2900796	1

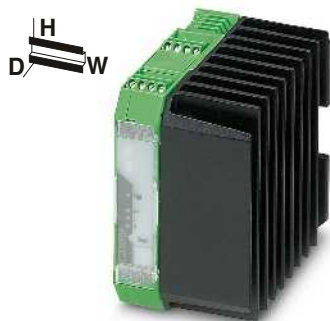

For reversing 3~ AC motors up to 575 V AC/3 x 9 A

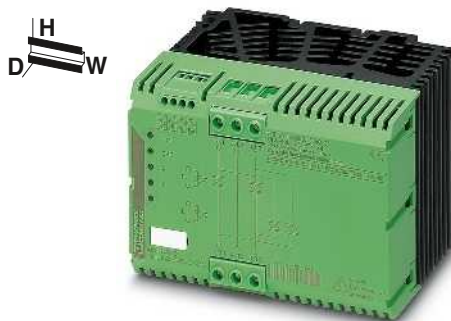

For reversing 3~ AC motors up to 575 V AC/3 x 16 A

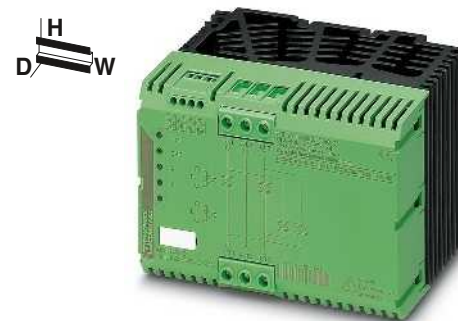

For reversing 3~ AC motors up to 575 V AC/3 x 37 A

ERIE DNV GL

ERIE DNV GL

ERIE DNV GL

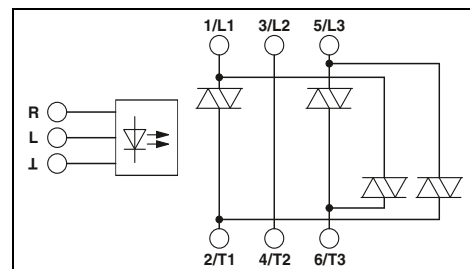
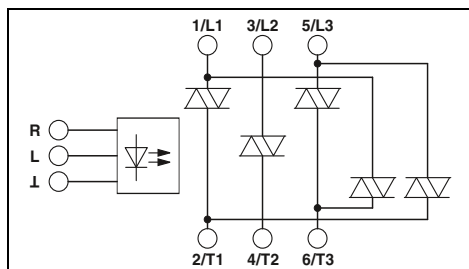
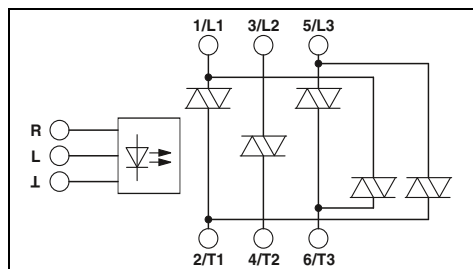

Technical data

Technical data

Technical data

24 V DC	230 V AC
19.2 V DC ... 30 V DC	92 V AC ... 253 V AC
12.7 mA	11.2 mA
Reverse polarity protection, Surge protection	Surge protection
- / Yellow LED / Red LED	

24 V DC	230 V AC
19.2 V DC ... 30 V DC	92 V AC ... 253 V AC
12.7 mA	11.2 mA
Reverse polarity protection, Surge protection	Surge protection
- / Yellow LED / Red LED	

24 V DC	230 V AC
19.2 V DC ... 30 V DC	92 V AC ... 253 V AC
12.7 mA	11.2 mA
Reverse polarity protection, Surge protection	Surge protection
- / Yellow LED / Red LED	

48 V AC ... 575 V AC	48 V AC ... 575 V AC
1200 V	1200 V
100 mA ... 9 A (see derating)	100 mA ... 9 A (see derating)
< 1.5 V	< 1.5 V
6 mA	6 mA
580 A ² s	580 A ² s
RCV circuit	

48 V AC ... 575 V AC	48 V AC ... 575 V AC
1200 V	1200 V
100 mA ... 16 A (see derating)	100 mA ... 16 A (see derating)
< 1.5 V	< 1.5 V
6 mA	6 mA
580 A ² s	580 A ² s
RCV circuit	

48 V AC ... 575 V AC	48 V AC ... 575 V AC
1200 V	1200 V
200 mA ... 37 A (see derating)	200 mA ... 37 A (see derating)
< 1.5 V	< 1.5 V
6 mA	6 mA
9000 A ² s	9000 A ² s
RCV circuit	

500 V	6 kV
Basic insulation	6 kV
≤ 10 Hz	≤ 2 Hz
max. 5 Hz	max. 1 Hz
-25 °C ... 70 °C	
DIN EN 50178 / EN 60947	
IP20	
Vertical (horizontal DIN rail)	
Can be aligned with spacing = 20 mm	
0.2 - 2.5 mm ² / 0.2 - 2.5 mm ² / 24 - 14	
0.2 - 2.5 mm ² / 0.2 - 2.5 mm ² / 24 - 14	
67.5 mm / 99 mm / 114.5 mm	

500 V	6 kV
Basic insulation	6 kV
≤ 10 Hz	≤ 2 Hz
max. 5 Hz	max. 1 Hz
-25 °C ... 70 °C	
DIN EN 50178 / EN 60947	
IP20	
Vertical (horizontal DIN rail)	
Can be aligned with spacing = 40 mm	
0.2 - 4 mm ² / 0.2 - 2.5 mm ² / 24 - 12	
0.5 - 16 mm ² / 0.5 - 16 mm ² / 20 - 6	
147.5 mm / 99 mm / 114.5 mm	

500 V	6 kV
Basic insulation	6 kV
≤ 10 Hz	≤ 2 Hz
max. 5 Hz	max. 1 Hz
-25 °C ... 70 °C	
DIN EN 50178 / EN 60947	
IP20	
Vertical (horizontal DIN rail)	
Can be aligned with spacing = 40 mm	
0.2 - 4 mm ² / 0.2 - 2.5 mm ² / 24 - 12	
0.5 - 16 mm ² / 0.5 - 16 mm ² / 20 - 6	
147.5 mm / 99 mm / 114.5 mm	

Ordering data

Ordering data

Ordering data

Type	Order No.	Pcs./ Pkt.
ELR W3-24DC/500AC-9	2297316	1
ELR W3-230AC/500AC-9	2297329	1

Type	Order No.	Pcs./ Pkt.
ELR W3-24DC/500AC-16	2297332	1
ELR W3-230AC/500AC-16	2297345	1

Type	Order No.	Pcs./ Pkt.
ELR W2+1-24DC/500AC-37	2297374	1
ELR W2+1-230AC/500AC-37	2297387	1

Accessories

Accessories

Accessories

THERMAL FUSE TF104	2900796	1
--------------------	---------	---

THERMAL FUSE TF104	2900796	1
--------------------	---------	---

THERMAL FUSE TF104	2900796	1
--------------------	---------	---

Solid-state contactors

3-phase semiconductor contactor

The 3-phase solid-state contactors are an ideal match for applications such as:

- Mixers
- Machine tools
- Conveying systems
- Pumps
- Fans

The power spectrum ranges from 575 V AC/3 x 2 A to 575 V AC/3 x 37 A. This corresponds to 1 kW to 18.5 kW.

Advantages of 3-phase semiconductor contactor:

- Noise-free and wear-free switching
- Integrated protective circuit
- Stable and short switching times
- Long service life
- High switching frequency
- Thermal fuse optional

Notes:
Type of insulation housing: ELR 3...2, ELR 3...9 Polyamide PA, non-reinforced, color: green
ELR 3...16, ELR 3...37 Polyester PBT, non-reinforced, color: green
Marking systems and mounting material See Catalog 3

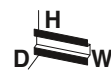

For switching 3~ AC motors up to 575 V AC/3 x 2 A

© DNV GL

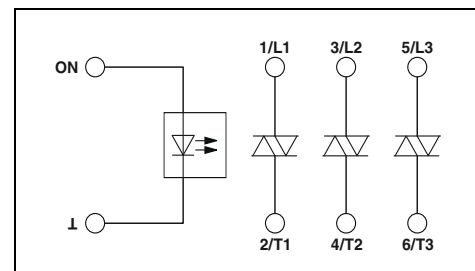

Technical data

Input data	
Rated actuation voltage U_c ON	24 V DC
Actuating voltage range	19.2 V DC ... 30 V DC
Rated actuating current I_c at U_c	8.3 mA
Input circuit	Reverse polarity protection, Surge protection
Operating voltage / status / error indicator	- / Yellow LED / Red LED
Output data load side	
Operating voltage range	48 V AC ... 575 V AC
Periodic peak reverse voltage	1200 V
Load current range	100 mA ... 2 A (see derating)
Residual voltage	< 1.5 V
Leakage current	6 mA
Max. load value $I^2 \times t$ ($t = 10$ ms)	250 A ² s
Output protection	RCV circuit
General data	
Rated insulation voltage	500 V
Rated surge voltage	6 kV
Insulation	Basic insulation
Switching frequency	≤ 10 Hz
Ambient temperature (operation)	-25 °C ... 70 °C
Standards/regulations	DIN EN 50178 / EN 60947
Degree of protection in acc. with IEC 60529/EN 60529	IP20
Mounting position	Vertical (horizontal DIN rail)
Mounting	Can be aligned with spacing = 20 mm
Screw connection solid/stranded/AWG	
- Control side	0.2 - 2.5 mm ² / 0.2 - 2.5 mm ² / 24 - 14
- Load side	0.2 - 2.5 mm ² / 0.2 - 2.5 mm ² / 24 - 14
Dimensions	40 mm / 99 mm / 114.5 mm

230 V AC	92 V AC ... 253 V AC	12.5 mA	Surge protection
48 V AC ... 575 V AC	48 V AC ... 575 V AC	1200 V	100 mA ... 2 A (see derating)
< 1.5 V	< 1.5 V	6 mA	250 A ² s
500 V	6 kV		
≤ 10 Hz	≤ 1 Hz		
0.2 - 2.5 mm ² / 0.2 - 2.5 mm ² / 24 - 14			

Ordering data

Description
3-phase semiconductor contactor

Type	Order No.	Pcs./ Pkt.
ELR 3- 24DC/500AC- 2	2297196	1
ELR 3-230AC/500AC- 2	2297206	1

Accessories

Thermal fuse
THERMAL FUSE TF104

THERMAL FUSE TF104	2900796	1
--------------------	---------	---

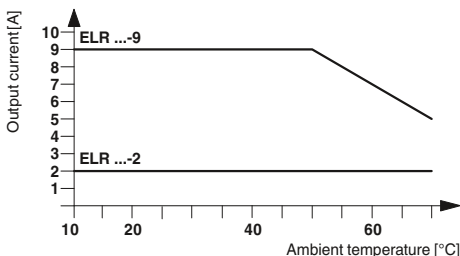

Load current as a function of the ambient temperature
Operating time: 100% operating factor

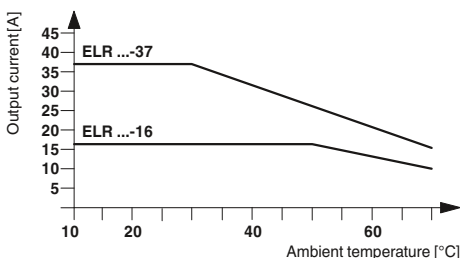

Load current as a function of the ambient temperature
Operating time: 100% operating factor

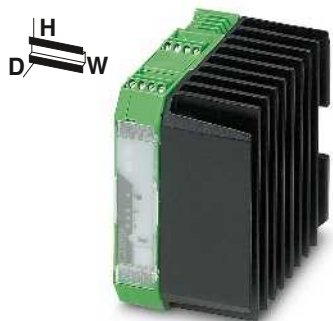

For switching 3~ AC motors up to 575 V AC/3 x 9 A



For switching 3~ AC motors up to 575 V AC/3 x 16 A



For switching 3~ AC motors up to 575 V AC/3 x 37 A

ERIC DNV GL

ERIC DNV GL

ERIC DNV GL

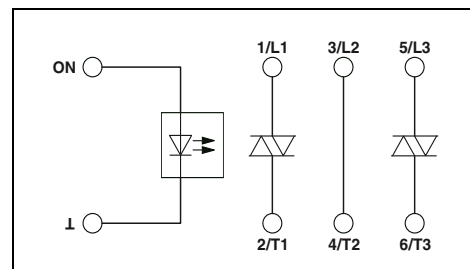
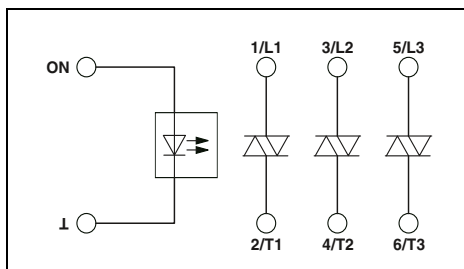
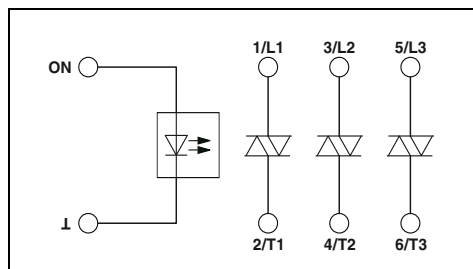

Technical data

Technical data

Technical data

24 V DC	230 V AC
19.2 V DC ... 30 V DC	92 V AC ... 253 V AC
8.3 mA	12.5 mA
Reverse polarity protection, Surge protection	Surge protection
- / Yellow LED / Red LED	

24 V DC	230 V AC
19.2 V DC ... 30 V DC	92 V AC ... 253 V AC
8.3 mA	12.5 mA
Reverse polarity protection, Surge protection	Surge protection
- / Yellow LED / Red LED	

24 V DC	230 V AC
19.2 V DC ... 30 V DC	92 V AC ... 253 V AC
8.3 mA	12.5 mA
Reverse polarity protection, Surge protection	Surge protection
- / Yellow LED / Red LED	

48 V AC ... 575 V AC	48 V AC ... 575 V AC
1200 V	1200 V
100 mA ... 9 A (see derating)	100 mA ... 9 A (see derating)
< 1.5 V	< 1.5 V
6 mA	6 mA
580 A ² s	580 A ² s
RCV circuit	

48 V AC ... 575 V AC	48 V AC ... 575 V AC
1200 V	1200 V
100 mA ... 16 A (see derating)	100 mA ... 16 A (see derating)
< 1.5 V	< 1.5 V
6 mA	6 mA
580 A ² s	580 A ² s
RCV circuit	

48 V AC ... 575 V AC	48 V AC ... 575 V AC
1200 V	1200 V
200 mA ... 37 A (see derating)	200 mA ... 37 A (see derating)
< 1.5 V	< 1.5 V
6 mA	6 mA
9000 A ² s	9000 A ² s
RCV circuit	

500 V	6 kV
Basic insulation	6 kV
≤ 10 Hz	≤ 1 Hz
-25 °C ... 70 °C	
DIN EN 50178 / EN 60947	
IP20	
Vertical (horizontal DIN rail)	
Can be aligned with spacing = 20 mm	
0.2 - 2.5 mm ² / 0.2 - 2.5 mm ² / 24 - 14	
0.2 - 2.5 mm ² / 0.2 - 2.5 mm ² / 24 - 14	
67.5 mm / 99 mm / 114.5 mm	

500 V	6 kV
Basic insulation	6 kV
≤ 10 Hz	≤ 1 Hz
-25 °C ... 70 °C	
DIN EN 50178 / EN 60947	
IP20	
Vertical (horizontal DIN rail)	
Can be aligned with spacing = 40 mm	
0.2 - 4 mm ² / 0.2 - 2.5 mm ² / 24 - 12	
0.5 - 16 mm ² / 0.5 - 16 mm ² / 20 - 6	
147.5 mm / 99 mm / 114.5 mm	

500 V	6 kV
Basic insulation	6 kV
≤ 10 Hz	≤ 1 Hz
-25 °C ... 70 °C	
DIN EN 50178 / EN 60947	
IP20	
Vertical (horizontal DIN rail)	
Can be aligned with spacing = 40 mm	
0.2 - 4 mm ² / 0.2 - 2.5 mm ² / 24 - 12	
0.5 - 16 mm ² / 0.5 - 16 mm ² / 20 - 6	
147.5 mm / 99 mm / 114.5 mm	

Ordering data

Ordering data

Ordering data

Type	Order No.	Pcs./ Pkt.
ELR 3- 24DC/500AC- 9	2297219	1
ELR 3-230AC/500AC- 9	2297222	1

Type	Order No.	Pcs./ Pkt.
ELR 3- 24DC/500AC-16	2297235	1
ELR 3-230AC/500AC-16	2297248	1

Type	Order No.	Pcs./ Pkt.
ELR 2+1- 24DC/500AC-37	2297277	1
ELR 2+1-230AC/500AC-37	2297280	1

Accessories

Accessories

Accessories

THERMAL FUSE TF104	2900796	1
--------------------	---------	---

THERMAL FUSE TF104	2900796	1
--------------------	---------	---

THERMAL FUSE TF104	2900796	1
--------------------	---------	---

Solid-state contactors

Semiconductor reversing contactor with soft starter

With the ELR W 3/9-400 S soft switch, you can extend the service life of a 3-phase asynchronous motor.

- Parameterization takes place via display and keypad directly on the device
- Friction time
- Torque, start
- Start up time
- Stop time
- Torque, stop
- Braking time
- Braking torque
- Drive can be controlled locally via keypad

Notes:
Type of housing: Polycarbonate PC, color: green.
Marking systems and mounting material See Catalog 3



Solid-state reversing contactor with soft starter

ERIC

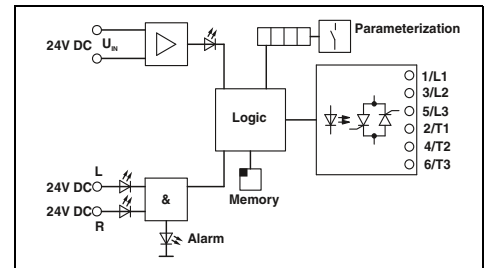

Technical data

Input data	
Supply nominal voltage U_{VN}	24 V DC
Supply voltage range with reference to U_{VN}	0.8 ... 1.2
Quiescent current	85 mA
Control voltage U_{ST} right/left	24 V DC
Control voltage range in reference to U_{ST}	0.8 ... 1.2
Typ. input current at U_N	5 mA
Input circuit	Reverse polarity protection, surge protection
Operating voltage / status / error indicator	Green LED / Yellow LED / Red LED
Output data load side	
Max. switching voltage	440 V AC (L1/T1) 440 V AC (L2/T2) 440 V AC (L3/T3) 110 V AC ... 433 V AC 1000 V
Operating voltage range	150 mA ... 8 A (at 20 °C T_A , see derating)
Periodic peak reverse voltage	
Load current range	
Residual voltage	typ. 1.5 V (For I_L)
Leakage current	5 mA (I_{L1} , in switched-off state)
Output protection	RC element, surge protection
General data	
Test voltage input/output	2.5 kV
Ambient temperature (operation)	-20 °C ... 60 °C
Standards/regulations	DIN EN 50178
Degree of protection in acc. with IEC 60529/EN 60529	IP20
Mounting position	Vertical (horizontal DIN rail)
Mounting	Can be aligned with > 20 mm spacing
Screw connection solid/stranded/AWG	0.2 - 6 mm ² / 0.2 - 4 mm ² / 24 - 10
Dimensions	62 mm / 94 mm / 122 mm
EMC note	Class A product, see page 605

Ordering data		
Type	Order No.	Pcs./Pkt.
ELR W3/ 9-400 S	2963569	1

Description
Solid-state reversing contactor, with integrated soft switch

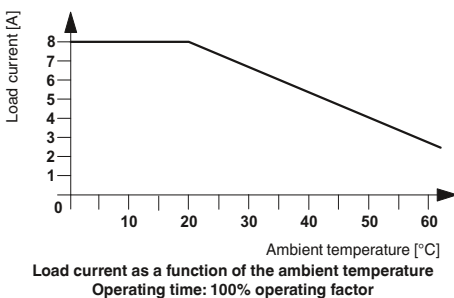

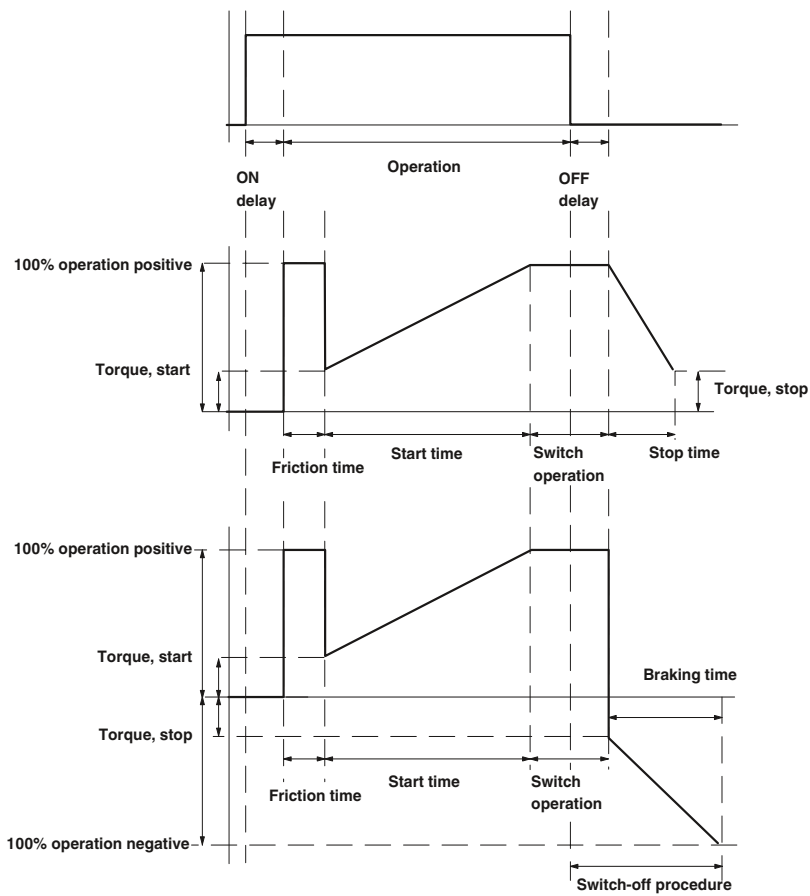

The figure shows the control of the reversing load relay with a soft starter and the operation of a three-phase current load.

Solid-state contactors

Electronic reversing load relay for DC motors

The ELR-DC electronic reversing load relays allow mechanically commutated DC motors to be switched. They reverse and reduce the speed of DC motors up to 24 V/6 A in a wear-free manner. A short-circuit, surge-voltage and overload-proof output guarantees reliable use in the plant.

When a 24 V DC signal is applied at the "left" input, the output supplies the motor with voltage. When the "right" output is activated, the polarity of the voltage at the output is reversed. If the signal is applied at both inputs, i.e., "right" and "left", the motor is short-circuited internally via the ELR-DC and reduces the speed.

Thanks to the internal interlocking circuit and load wiring, wiring is reduced to a minimum.

Notes:
Type of housing: Polycarbonate PC, color: green.
Marking systems and mounting material See Catalog 3
PWM = Pulse Width Modulation



Electronic reversing load relay for DC motors

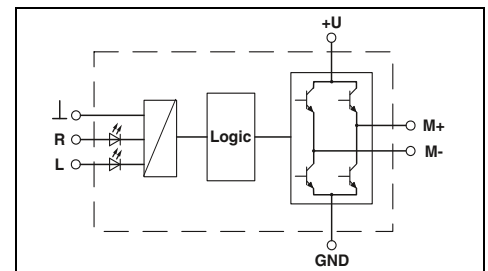

Application example

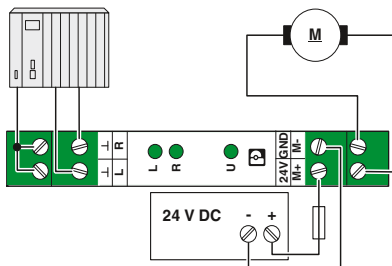

Status table

Input		Output	
Right	Left	M +	M -
0	0	High resistance	High resistance
1	0	+ 24 V	GND
0	1	GND	+ 24 V
1	1	GND	GND

Load current depending on ambient temperature

Operating time: 100% (ED)

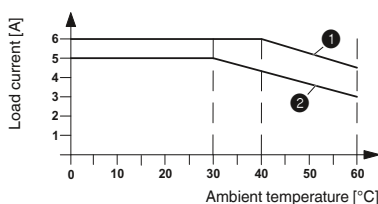

- ① Stand-alone device
- ② Aligned without spacing

Input data

Control voltage U_{ST} right/left
Control voltage range in reference to U_{ST}
Typ. input current at U_N
Input circuit
Operating voltage / status / error indicator

Output data load side

Operating voltage range
Load current

Quiescent current

Current limitation at short-circuits
Output protection
Operating voltage / status / error indicator

General data

Test voltage input/output
Ambient temperature (operation)
Nominal operating mode
Standards/regulations
Degree of protection in acc. with IEC 60529/EN 60529
Mounting position
Screw connection solid/stranded/AWG
Dimensions
EMC note

Technical data

24 V DC	24 V DC
0.8 ... 1.2	0.8 ... 1.2
3 mA	3 mA
Reverse polarity protection, surge protection Green LED / Yellow LED / -	
10 V DC ... 30 V DC	10 V DC ... 30 V DC
2 A (Mounted in rows with zero spacing)	6 A (see derating)
approx. 7 mA (When switched off)	approx. 7 mA (When switched off)

15 A
20 A
Reverse polarity protection, surge protection
Green LED / - / -

2.5 kV AC
-20 °C ... 60 °C
100% operating factor
EN 50178
IP20
Vertical (horizontal DIN rail)
0.2 - 6 mm² / 0.2 - 4 mm² / 24 - 10
12.5 mm / 99 mm / 114.5 mm
Class A product, see page 605

Ordering data

Type	Order No.	Pcs./Pkt.
ELR W1/ 2-24DC	2963598	1
ELR W1/ 6-24DC	2982090	1

Solid-state contactors

Single-phase solid-state contactors

Single-phase solid-state contactors are used in AC voltage networks, where silent switching, high switching frequencies, and practically unlimited service life are required.

The robust power semi-conductors switch to zero voltage crossing. In doing so, they do not generate any additional high-frequency interfering impulses. The modules are resistant to shock and vibration, they can even be used without problem in aggressive environments containing harmful substances.

They offer the following advantages:

- High switching frequency
- Wear-free and bounce-free
- Input voltage versions 24 V DC and 230 V AC

The areas of application are:

- Production machines
- Temperature controllers
- Conveyor equipment
- Light and lighting systems

Notes:	
Type of housing:	Polycarbonate PC, color: green.
Marking systems and mounting material	See Catalog 3



For switching 1~ AC motors
up to 660 V AC/20 A

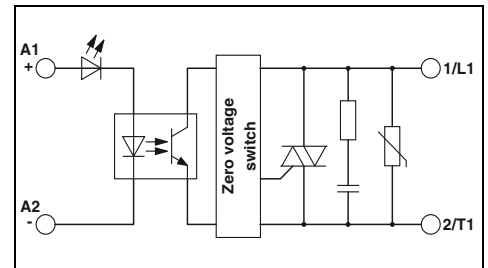

Technical data

Input data		4 V DC ... 32 V DC	24 V AC ... 275 V AC
Actuating voltage range		12 mA	17 mA
Rated actuating current I_C at U_C		≥ 4 V DC ("1" signal)	≥ 22 V AC ("1" signal)
Switching level	1 signal ("H") 0 signal ("L")	≤ 1 V DC ("0" signal)	≤ 6 V AC ("0" signal)
Transmission frequency f_{limit}		25 Hz	6 Hz
Operating voltage / status / error indicator			Green LED / - / -
Output data load side		42 V AC ... 660 V AC (45/65 Hz)	42 V AC ... 660 V AC (45/65 Hz)
Operating voltage range		1200 V	1200 V
Periodic peak reverse voltage		350 mA ... 20 A (see derating)	350 mA ... 20 A (see derating)
Load current range			
Residual voltage		< 1.6 V	< 1.6 V
Leakage current		< 3 mA (In off state)	< 3 mA (In off state)
Phase angle (cos ϕ)		0.5	0.5
Max. load value $I^2 \times t$ ($t = 10$ ms)		525 A ² s	525 A ² s
Output protection			RC circuit
General data		4 kV _{rms}	
Test voltage input/output		Basic insulation	
Insulation		-30 °C ... 70 °C	
Ambient temperature (operation)		EN 61000-4-2 / EN 61000-4-3 / EN 61000-4-4 / EN 61000-4-5 / EN 61000-4-6 / EN 55011	
Standards/regulations		Vertical (horizontal DIN rail)	
Mounting position		Can be aligned with ≥ 22.5 mm spacing	
Mounting		0.5 - 2.5 mm ² / 0.5 - 2.5 mm ² / 20 - 14	
Screw connection solid/stranded/AWG		0.5 - 4 mm ² / 0.5 - 4 mm ² / 20 - 12	
- Control side		22.5 mm / 103 mm / 103 mm	
- Load side			
Dimensions	W / H / D		

Ordering data

Description	Type	Order No.	Pcs./ Pkt.
Single-phase electronic load relay	ELR 1- 24DC/600AC-20	2297138	1
	ELR 1-230AC/600AC-20	2297141	1

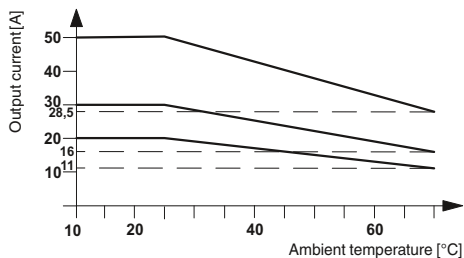

Load current as a function of the ambient temperature
Operating time: 100% operating factor



For switching 1~ AC motors up to 660 V AC/30 A



For switching 1~ AC motors up to 660 V AC/50 A

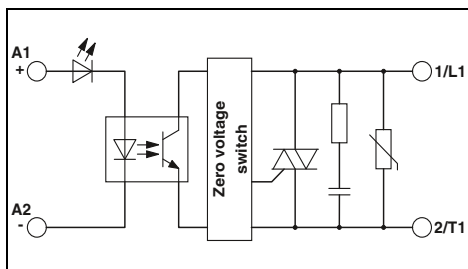
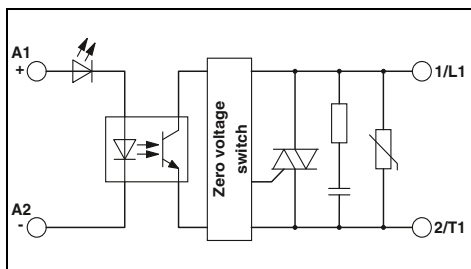

Technical data

4 V DC ... 32 V DC	24 V AC ... 275 V AC
12 mA	17 mA
≥ 4 V DC ("1" signal)	≥ 22 V AC ("1" signal)
≤ 1 V DC ("0" signal)	≤ 6 V AC ("0" signal)
25 Hz	6 Hz
Green LED / - / -	

Technical data

4 V DC ... 32 V DC	24 V AC ... 275 V AC
12 mA	17 mA
≥ 4 V DC ("1" signal)	≥ 22 V AC ("1" signal)
≤ 1 V DC ("0" signal)	≤ 6 V AC ("0" signal)
25 Hz	6 Hz
Green LED / - / -	

42 V AC ... 660 V AC (45/65 Hz)	42 V AC ... 660 V AC (45/65 Hz)
1200 V	1200 V
150 mA ... 30 A (see derating)	150 mA ... 30 A (see derating)
< 1.6 V	< 1.6 V
< 3 mA (In off state)	< 3 mA (In off state)
0.5	0.5
1800 A²s	1800 A²s
RCV circuit	

42 V AC ... 660 V AC (45/65 Hz)	42 V AC ... 660 V AC (45/65 Hz)
1200 V	1200 V
150 mA ... 50 A (see derating)	150 mA ... 50 A (see derating)
< 1.6 V	< 1.6 V
< 3 mA (In off state)	< 3 mA (In off state)
0.5	0.5
18000 A²s	18000 A²s
RCV circuit	

4 kV_{rms}
 Basic insulation
 -30 °C ... 70 °C
 EN 61000-4-2 / EN 61000-4-3 / EN 61000-4-4 / EN 61000-4-5 / EN 61000-4-6 / EN 55011
 Vertical (horizontal DIN rail)
 Can be aligned with ≥ 22.5 mm spacing

4 kV_{rms}
 Basic insulation
 -30 °C ... 70 °C
 EN 61000-4-2 / EN 61000-4-3 / EN 61000-4-4 / EN 61000-4-5 / EN 61000-4-6 / EN 55011
 Vertical (horizontal DIN rail)
 Can be aligned with ≥ 22.5 mm spacing

0.5 - 2.5 mm² / 0.5 - 2.5 mm² / 20 - 14
 0.5 - 4 mm² / 0.5 - 4 mm² / 20 - 12
 22.5 mm / 103 mm / 103 mm

0.5 - 4 mm² / 0.5 - 4 mm² / 20 - 14
 4 - 25 mm² / 4 - 25 mm² / 12 - 3
 45 mm / 103 mm / 103 mm

Ordering data

Type	Order No.	Pcs./ Pkt.
ELR 1- 24DC/600AC-30	2297154	1
ELR 1-230AC/600AC-30	2297167	1

Ordering data

Type	Order No.	Pcs./ Pkt.
ELR 1- 24DC/600AC-50	2297170	1
ELR 1-230AC/600AC-50	2297183	1

IP67 motor starters

PROFINET motor starter

Motor starters in robust stainless steel housing (IP67) can be used directly in the system as a compact function unit. This eliminates the complex wiring of individual functions in the control cabinet.

The motor starter can be used to control three-phase asynchronous motors in two directions of rotation, completely via PROFINET. Distributed sensors and actuators can be directly connected to PROFINET without the need for further intermediate stations or additional cabling. A complete PROFINET motor starter consists of three products. For example:

- ELR 5011 IP PN
- IBS IP 400 MBH-F
- IBS PG SET

Additional features:

- Performance classes: 1.1 kW to 3.0 kW
- One and two-motor reversing starters (CONTACTRON hybrid motor starter)
- Easy assembly
- Plug-in connection system
- Exchangeable module electronics
- Status and diagnostic indicators on the module
- 10 digital inputs for connecting sensors
- 4 digital outputs for connecting actuators



**Electronic motor starters,
1 x 1.1 kW and 2 x 1.1 kW**

ERC CB

Interface	
Fieldbus system	PROFINET
Connection method	8-pos. RJ45 socket on motor starter
Power supply for module electronics	
Supply voltage	24 V DC (U_{S1} / U_{S2})
Supply voltage range	20 V DC ... 30 V DC (including ripple)
Power supply for sensors	
Minimum voltage	$U_{MI} = U_{S1}$ minus 1 V
Nominal current per sensor	500 mA
Type of protection	Short-circuit/overload protection
Digital inputs	
Number of inputs	10
Connection method	M12 connector
Connection method	2, 3, 4-wire
Digital outputs	
Number of outputs	4
Connection method	M12 connector
Connection method	2-wire
Output current	max. 500 mA (per channel)
Motor starter, output	
Connection method	POWER-COMBICON
Operating voltage	360 V AC ... 550 V AC (line voltage 50/60 Hz)
Nominal current range	0.18 A ... 2.4 A
Frequency range	50 Hz ... 60 Hz (mains frequency)
Nominal motor power	1.1 kW (at $U_{mains} = 400$ V AC)
Motor monitoring	
Parameterization range	0.2 A ... 2.4 A
Tripping class	Based on class 10 A of IEC 60947
General data	
Weight	2115 g 2425 g
Degree of protection	IP67 in acc. with IEC 60529
Ambient temperature (operation)	-25 °C ... 50 °C (non-condensing)
EMC note	

Technical data		
ELR 5011 IP PN	ELR 5011-2 IP PN	
	PROFINET	
	8-pos. RJ45 socket on motor starter	
	24 V DC (U_{S1} / U_{S2})	
	20 V DC ... 30 V DC (including ripple)	
	$U_{MI} = U_{S1}$ minus 1 V	
	500 mA	
	Short-circuit/overload protection	
	10	
	M12 connector	
	2, 3, 4-wire	
	4	
	M12 connector	
	2-wire	
	max. 500 mA (per channel)	
	POWER-COMBICON	
	360 V AC ... 550 V AC (line voltage 50/60 Hz)	
	0.18 A ... 2.4 A	
	50 Hz ... 60 Hz (mains frequency)	
	1.1 kW (at $U_{mains} = 400$ V AC)	
	0.2 A ... 2.4 A	
	Based on class 10 A of IEC 60947	
	2115 g	2425 g
	IP67 in acc. with IEC 60529	
	-25 °C ... 50 °C (non-condensing)	

Description
PROFINET motor starter
- 1-channel reversing starter, 1.1 kW
- 2-channel reversing starter, 1.1 kW
PROFINET motor starter
- 1-channel reversing starter, 3.0 kW
- 2-channel reversing starter, 3.0 kW
Lower part of the housing , high-grade steel
- Standard version
Pg screw connection , plastic (IP67), for INTERBUS and PROFINET motor starters and variable frequency drives.

Ordering data		
Type	Order No.	Pcs./Pkt.
ELR 5011 IP PN	2700745	1
ELR 5011-2 IP PN	2701007	1
IBS IP 400 MBH-F	2732868	1
IBS PG SET	2836599	1

Accessories	
RJ45 connector , shielded, with bend protection sleeve, x 2	
- gray for straight cables	
- green for crossed cables	
Bus system cable	
Crimping pliers , for assembling the RJ45 connectors	

Accessories		
Type	Order No.	Pcs./Pkt.
FL PLUG RJ45 GR/2	2744856	1
FL PLUG RJ45 GN/2	2744571	1
VS-937/...	1402611	1
FL CRIMPTOOL	2744869	1

IP20 frequency inverters

Inline frequency inverters

Inline frequency inverters for the control cabinet are the compact solution for extending your Easy Automation solution to include electronic speed regulation for asynchronous motors. The devices seamlessly integrate into the Inline system and have IP20 protection. Depending on the drive task, you can select frequency inverters from various performance classes, up to a maximum of 4 kW. In order to connect to the Inline system via the Fieldline local bus, you just need the IB IL 24 FLM-PAC Inline module. The Inline frequency inverter can be connected to a Phoenix Contact controller via the Inline module.

Additional features:

- Max. motor power
0.75 kW, 1.5 kW, 2.2 kW, and 4.0 kW
- 3 x 400 V mains input ($\pm 15\%$) 50/60 Hz
- DTM for parameterization and diagnostics
- 8 freely programmable parameter records
- PTC evaluation for
2.2 kW and 4.0 kW versions
- Integrated line filter
- U/f linear and U/f square operating modes
- S-ramp function
- Motor protection function (I^2t)
- Connection of a braking resistor
- DC braking
- Evaluation of the temperature switch in the motor
- Voltage boost
- 1 x analog input, 1 x analog output,
1 x relay output



Frequency inverter for a maximum motor power of up to 0.75 kW

Interface	
Designation	Fieldline local bus
Connection method	9-pos. D-SUB connector/socket
Power supply for module electronics	
Supply voltage	24 V DC $\pm 15\%$
Supply voltage range	20.4 V DC ... 27.6 V DC $\pm 15\%$
Digital inputs	
Number of inputs	5
Connection method	COMBICON
Connection method	Plug-in screw connection
Analog inputs	
Number of inputs	1
Connection method	COMBICON
Connection method	Plug-in screw connection
Analog outputs	
Number of inputs	1
Connection method	COMBICON
Connection method	Plug-in screw connection
Frequency inverter output	
Rated current	2.6 A +20 %
Frequency range	0 Hz ... 400 Hz
Parameterization	Via INTERBUS
Tripping class	5.6 A OC tripping current
General data	
Weight	1400 g
Degree of protection	IP20 in acc. with IEC 60529/ EN 60529
Width	90 mm
Height	173 mm
Depth	153.5 mm

Technical data		
Fieldline local bus		
9-pos. D-SUB connector/socket		
24 V DC $\pm 15\%$		
20.4 V DC ... 27.6 V DC $\pm 15\%$		
5		
COMBICON		
Plug-in screw connection		
1		
COMBICON		
Plug-in screw connection		
1		
COMBICON		
Plug-in screw connection		
2.6 A +20 %		
0 Hz ... 400 Hz		
Via INTERBUS		
5.6 A OC tripping current		
1400 g		
IP20 in acc. with IEC 60529/ EN 60529		
90 mm		
173 mm		
153.5 mm		

Description
Inline frequency inverter for the control cabinet
Inline Modular branch terminal for coupling one Fieldline Modular M8 local bus at the end of an Inline station
Remote bus cable , highly flexible, 3 x 2 x 0.25 mm ²

Ordering data		
Type	Order No.	Pcs./ Pkt.
VFD 5007 IL IB	2701054	1

Accessories		
Type	Order No.	Pcs./ Pkt.
IB IL 24 FLM-PAC	2736903	1
IBS RBC/F-T/	2740151	1



Frequency inverter for a maximum motor power of up to 1.5 kW



Frequency inverter for a maximum motor power of up to 2.2 kW



Frequency inverter for a maximum motor power of up to 4.0 kW

Technical data
Fieldline local bus 9-pos. D-SUB connector/socket
24 V DC $\pm 15\%$ 20.4 V DC ... 27.6 V DC $\pm 15\%$
5 COMBICON Plug-in screw connection
1 COMBICON Plug-in screw connection
1 COMBICON Plug-in screw connection
4.1 A $+20\%$ 0 Hz ... 400 Hz Via INTERBUS 8.8 A OC tripping current
1400 g IP20 in acc. with IEC 60529/ EN 60529 90 mm 173 mm 153.5 mm

Technical data
Fieldline local bus 9-pos. D-SUB connector/socket
24 V DC $\pm 15\%$ 20.4 V DC ... 27.6 V DC $\pm 15\%$
5 COMBICON Plug-in screw connection
1 COMBICON Plug-in screw connection
1 COMBICON Plug-in screw connection
5.8 A $+20\%$ 0 Hz ... 400 Hz Via INTERBUS 12.5 A OC tripping current
2200 g IP20 in acc. with IEC 60529/ EN 60529 117 mm 173 mm 174.5 mm

Technical data
Fieldline local bus 9-pos. D-SUB connector/socket
24 V DC $\pm 15\%$ 20.4 V DC ... 27.6 V DC $\pm 15\%$
5 COMBICON Plug-in screw connection
1 COMBICON Plug-in screw connection
1 COMBICON Plug-in screw connection
9.5 A $+20\%$ 0 Hz ... 400 Hz Via INTERBUS 21 A OC tripping current
2200 g IP20 in acc. with IEC 60529/ EN 60529 117 mm 173 mm 174.5 mm

Ordering data		
Type	Order No.	Pcs./ Pkt.
VFD 5015 IL IB	2701055	1

Ordering data		
Type	Order No.	Pcs./ Pkt.
VFD 5022 IL IB	2701057	1

Ordering data		
Type	Order No.	Pcs./ Pkt.
VFD 5040 IL IB	2701058	1

Accessories		
Type	Order No.	Pcs./ Pkt.
IB IL 24 FLM-PAC	2736903	1
IBS RBC/F-T/	2740151	1

Accessories		
Type	Order No.	Pcs./ Pkt.
IB IL 24 FLM-PAC	2736903	1
IBS RBC/F-T/	2740151	1

Accessories		
Type	Order No.	Pcs./ Pkt.
IB IL 24 FLM-PAC	2736903	1
IBS RBC/F-T/	2740151	1



Measurement and control technology

From highly compact 6 mm signal conditioners and functionally safe signal conditioners to signal isolators for intrinsically safe circuits in the Ex area: our signal conditioner range and process indicators offer a solution for all applications in analog signal conditioning.

We offer the following product ranges:

Highly compact signal conditioners with plug-in connection technology – MINI Analog Pro

For maximum convenience during installation and servicing

- Overall width of just 6.2 mm
- Current measurement, without disconnection
- Safe electrical isolation

Signal conditioners with SIL functional safety – MACX Analog

For maximum signal safety

- Consistent SIL certification
- Safe electrical isolation

Signal conditioners with PL functional safety – MACX Safety

The proven MACX range for safety applications according to the Machinery Directive

Ex i signal conditioners with SIL functional safety – MACX Analog Ex

For intrinsically safe circuits in the Ex area

- Maximum explosion protection for all Ex zones and gas groups
- Safe electrical isolation

Ex i signal conditioners with PL functional safety – MACX Safety Ex

The proven MACX EX range for safety applications according to the Machinery Directive

Process indicators and field devices – Field Analog

- Monitoring and display of analog and temperature signals
- Control via digital and analog inputs and outputs
- Record and convert temperatures directly in the field

Product range overview

Product overview	56
Selection guide for signal conditioners	58
Basics	62
Highly compact signal conditioners with plug-in connection technology – MINI Analog Pro	68
Signal conditioners with functional safety and explosion protection – the MACX ranges	106
Signal conditioners with SIL functional safety – MACX Analog	116
Signal conditioners with PL functional safety – MACX Safety	138
Ex i signal conditioners with SIL functional safety – MACX Analog Ex	140
Ex i signal conditioners with PL functional safety – MACX Safety Ex	168
Multiplexer for HART signals	166
Process indicators and field devices – Field Analog	178

Product overview

Highly compact signal conditioners with plug-in connection technology



MINI Analog Pro

Page 68



MINI Analog Pro gateways

Page 94



System cabling, Termination Carriers

Page 98



Accessories for MINI Analog Pro

Page 100

Multiplexers



Multiplexer for HART signals

Page 166

MACX Analog accessories



Supply components, marking material

Page 174



System cabling, Termination Carriers

Page 164

Process indicators and field devices



Process indicators and field devices

Page 178

Current measurement



PACT current transformers

Page 222



PACT RCP current transformers for retrofitting

Page 236



AC current transducers, AC/DC, AC current protector

Page 240



Test disconnect terminal blocks
See Catalog 1

Controllers



Controllers
See Catalog 6

Surge protection



Surge protection for measurement and control technology
See Catalog 4

Signal conditioners with SIL functional safety



MACX Analog

Page 116

Signal conditioners with PL functional safety



MACX Safety

Page 138

Ex i signal conditioners with SIL functional safety



MACX Analog Ex

Page 140

Ex i signal conditioners with PL functional safety



MACX Safety Ex

Page 168

Energy and power measurement



Process indicators

Page 184



EMpro energy meters, function and communication modules

Page 208



Software for usage data acquisition

Page 214



PSK compressed air meters

Page 216

Monitoring and diagnostics



SOLARCHECK PV string monitoring

Page 256



EMD-BL Compact monitoring relays

Page 262



Highly compact signal conditioners –
MINI Analog Pro

Analog IN/Analog OUT		Page
3-way signal conditioners	Configurable	From 70
	Fixed signal combinations	74
4-way signal duplicators	Configurable	76
3-way repeater power supplies	1-channel	75
	Input loop-powered	78
2-way passive isolators	Output loop-powered	79
	Temperature	
Temperature transducers	For resistance thermometers (RTD)	80
	For thermocouples	82
Frequency		
Frequency transducers	Universal	84
Analog frequency transducers		86
Potentiometer/resistor		
Potipotential transducers		88
Digital IN		
Signal conditioners	NAMUR sensors, floating contacts	90
Limit values		
Threshold value switches	Standard analog signals, universal	91
	Temperature	92
MINI Analog Pro gateways		
Bus systems	Modbus RTU/TCP	96
	PROFIBUS DP	96
Accessories		
Configuration	Programming adapters	105
Constant voltage source, constant current source		100
Setpoint potentiometer		101
System cabling	System adapters	97
	1:1 feed-through terminal block	104
Supply components	Power terminal, fault signaling modules, DIN rail connector, system power supply	From 100
Marking material		105
Connector set	Screw connection or Push-in connection	101



**Process indicators and field devices –
Field Analog**

Process indicators		Page
Multifunctional process indicators	Configurable	From 180
Loop-powered process indicators	Configurable	From 182
Standard signals	Configurable	184
Frequency	Configurable	185
Setpoint adjusters	Configurable	186
Head-mounted transducers		
Temperature	Loop-powered	From 187
Accessories		From 192
DIN rail measuring transducers		
Temperature	Loop-powered	From 194



Signal conditioners with SIL functional safety – MACX Analog

Analog IN/Analog OUT		Page
3-way signal conditioners	Configurable	From 116
	1-channel	120
3-way repeater power supplies	Signal duplicators	121
	2-channel	123
2-way passive isolators	Input loop-powered, 1 or 2-channel	124
	Input loop-powered, 5 kV, 1 or 2-channel	125
3-way output isolators	Fixed signal combinations	126
Temperature		
	Universal	From 127
Temperature transducers	For resistance thermometers (RTD)	130
	For thermocouples	131
Potentiometer/resistor		
Potiposition transducers		From 127
Digital IN		
	NAMUR sensors, floating contacts	From 132
Signal conditioners	Signal duplicators	133 136
	NAMUR output, floating contacts	From 134 137
	NAMUR sensors on NAM	
Digital OUT		
Solenoid drivers	Loop-powered	
	With line fault detection	
Limit values		
Threshold value switches	Analog current signal	127
	Temperature	127
Accessories		
Programming adapters		105
Display unit and operator interface, removable		171
Holder module for display unit and operator interface		171
Termination Carriers		165
Multiplexer for HART signals		166
Supply components	Power terminal, fault signaling modules, DIN rail connector, system power supply	From 174
Marking material		177
Shield fast connection		172
Test plug		176
Resistance circuit	For line fault detection	176



Signal conditioners with PL functional safety – MACX Safety



Ex i signal conditioners with SIL functional safety – MACX Analog Ex



Ex i signal conditioners with PL functional safety – MACX Safety Ex

Page	Page	Page
	140	
138	141	168
	142	169
	144	
139	From 148	170
	145	
	146	
139	From 148	170
	151	
	155	
	152	
	155	
	From 153	
	156	
	157	
	From 162	
	159	
127	127	127
139	150	170
105	105	105
	165	
	166	
	174	
	177	
	172	
	176	
	176	

Input

Maximum input signal

The maximum input signal describes the value achieved before any damage occurs to the module and the signal generator. If these values are exceeded, suppresser diodes can be triggered to short circuit this input when a surge voltage is detected. The transmission range of the analog signals is located exclusively within the specified input ranges.

Input resistance

The input resistance of a signal conditioner or measuring transducer is determined in such a way as to ensure that the input signal is loaded only slightly. This results in a low-resistance input for current inputs and a high-resistance input for voltage inputs.

Voltage drop

In the case of passive isolators, the input voltage drop occurs as a result of the voltage drop of the operational load and the auxiliary power consumption of the module. The greater the auxiliary power consumption of the passive isolator, the smaller the operational output load is allowed to be. Low auxiliary power consumption is regarded as an indicator of device quality.

Common mode rejection

In the case of signal conditioners, operational amplifiers are used internally for transmission purposes. In theory, operational amplifiers should display ideal transmission and amplification behavior. However, it is a different matter in practice. When both input voltages are changed concordantly, i.e., exactly the same voltage to ground is applied to both input terminal blocks, this leads to an unintended output signal. Theoretically, if the operational amplifier is ideal, no output signal should appear since the differential input signal is "0 V". Common mode rejection indicates the factor (in dB) by which the common input voltage at both inputs is amplified to a lesser extent than the difference in voltage between the two inputs.

Analog output

Maximum output signal

During uninterrupted operation of the devices, an overload at the input cannot cause greater values than at the output.

Zero/span adjustment

When the zero point is set, the zero point of an analog output is adjusted and set in relation to the input signal.

When the "amplification" span is set, the analog output is adjusted in relation to the input signal. In this case, the output characteristic curve is increased or decreased by an amplification factor.

Load

The load on the output side indicates the load-carrying capacity of a measuring transducer or a signal conditioner. Current outputs can drive a maximum of 500 Ω . Voltage outputs have a load-carrying capacity of up to at least 10 k Ω .

Residual ripple/ripple

A superimposed ripple can appear on the output signal due to signal conditioning required by the circuit. The residual ripple is indicated in mV_{pp} or mV_{rms}.

Open-circuit behavior

With some measuring transducers, the input signal is permanently monitored for possible open circuits in the signal line. If the signal exceeds or falls below a tolerance limit, an open circuit is detected and a defined output signal is sent. With programmable devices, the output signals can be freely selected.

Digital output

Relays

Many of the products with a relay output that are shown in the catalog feature hard gold-plated relay contact material. The voltage range has an important role to play in terms of how this contact material can be used. Up to 50 mA can be switched with voltage ranges of up to 30 V AC/36 V DC. Even very small currents are transmitted perfectly. If the aforementioned voltage range is exceeded and values of up to 250 V AC/DC are processed, currents of up to 2 A can flow. However, in this case the subsequent transmission of small currents can no longer be guaranteed.

Transistor

A PNP transistor switching output can be used to transmit 24 V DC switching signals up to approximately 100 mA.

General data

Supply voltage

The product range includes DC and AC power supply units for specific products. There is a standard power supply unit available in the form of a 24 V DC version that operates within a voltage range of 20 to 30 V DC. For other supply voltages, please refer to the technical data.

Current consumption

The value specified here describes the self-consumption of the devices. It also includes the output current and, where applicable, the switching output load.

Transmission errors

The transmission precision is a gauge of the quality of a measuring transducer. It is the deviation from the ideal transmission characteristic curve and includes linearity, span, and offset errors.

Non-linearity

Non-linearity is the deviation from the ideal transmission precision without including span and offset errors.

The non-linearity of a signal makes it possible to evaluate the course from zero to endpoint. Normally, the linearity errors are expressed as a percentage that indicates the extent of deviation from the ideal transmission characteristic curve.

Temperature coefficient

The temperature coefficient provides an assessment of the extent to which precision deviates when the ambient temperature around a signal conditioner or measuring transducer changes. In many cases this is specified as a percentage. An alternative definition is ppm/K (parts per million/Kelvin).

Example: 250 ppm/K = 0.025%/K.

Cut-off frequency

Signal conditioners are basically designed to transmit DC signals. However, signal changes call for a dynamic form of behavior so that small AC quantities (normally: 30 Hz) can also be transmitted. This is achieved by defining a cut-off frequency. At the same time, a low cut-off frequency can be used to suppress higher-frequency AC components.

Step response

The step response indicates the response time of the output signal when an input signal step occurs (10 to 90%). The step response is inversely proportional to the cut-off frequency. This means that the response time decreases as the cut-off frequency increases.

Test voltage

The test voltage indicates the electric strength of an isolated distance and is determined by type tests. In this test, a 50 Hz voltage is applied for one minute; it describes the value achieved before a disruptive discharge to another potential level occurs in the device.

Safe isolation

“Safe isolation” is defined as protection against hazardous shock currents. When module specifications are provided in accordance with EN 61010, a distinction is made between error-free operation and operation under fault conditions. With error-free operation, nominal supply voltages of 30 V AC/60 V DC are applicable.

Ambient temperature range

The temperature limits specified here relate exclusively to operation. These limits do not apply to storage and transport. It is here where the temperature limits of the materials used are the decisive factor. If the devices are outside of the specified temperature range during assembly, they must be brought back within the specified temperature range prior to system startup. It is important to make sure that no condensation occurs.

Protective circuit

In order to protect the measurement and control modules against surge voltages, suppressor diodes are connected upstream of the signal and supply paths. These diodes behave in a similar manner to conventional Zener diodes. Except for the fact that suppressor diodes have faster response times and a higher maximum current.

Information on directives and standards

When carrying out further processing of non-independent items of equipment (components), the applicable regulations pertaining to installation must be observed.

The relevant device-specific regulations also apply with regard to installation in devices.
(Standards applicable at the time of going to print)

Directives	EU	International
EMC Directive (electromagnetic compatibility)	2004/108/EC	-
Low Voltage Directive	2006/95/EC	-
Ex Directive (ATEX)	94/9/EC	-
Product standards		
Electronic equipment for use in power installations	EN 50178:1997	-
Safety requirements for electrical equipment for measurement, control, and laboratory use - Part 1: General requirements	EN 61010-1:2001	IEC 61010-1:2004
Programmable logic controllers - Part 2: Equipment requirements and tests	EN 61131-2:2007	IEC 61131-2:2007
EMC		
EMC - Part 6-2: Generic standards - Immunity for industrial environments	EN 61000-6-2:2005	IEC 61000-6-2:2005
EMC - Part 6-4: Generic standards - Emission standard for industrial environments	EN 61000-6-4:2007	IEC 61000-6-4:2006
Electrical equipment for measurement, control, and laboratory use EMC requirements	EN 61326-1:2006	IEC 61326-1:2005
ATEX		
Electrical apparatus for explosive gas atmospheres - Part 0: General requirements	EN 60079-0:2006	IEC 60079-0:2007
Explosive atmospheres - Part 11: Equipment protection by intrinsic safety "i"	EN 60079-11:2007	IEC 60079-11:2006
Electrical apparatus for explosive gas atmospheres - Part 15: Construction, test, and marking of type of protection "n" electrical apparatus	EN 60079-15:2005	IEC 60079-15:2005
Environmental tests		
Environmental testing - Part 2-1: Tests - Test A: Cold	EN 60068-2-1:2007	IEC 60068-2-1:2007
Environmental testing - Part 2-2: Tests - Test B: Dry heat	EN 60068-2-2:2007	IEC 60068-2-2:2007
Environmental testing - Part 2-6: Tests - Test Fc: Vibration (sinusoidal)	EN 60068-2-6:2008	IEC 60068-2-6:2008

Active isolation

3-way isolation

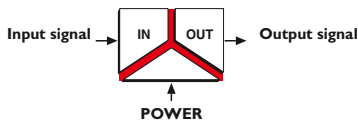

In the case of modules with this isolation method, all components that are connected to the input, output or power supply are protected against interference from each other. All three directions (input, output, and power supply) are electrically isolated from one another accordingly.

The 3-way isolation provides electrical isolation between the measurement sensor and the controller as well as between the controller and the actuating element.

On the input side, the modules need active signals. On the output side, they provide a filtered and amplified signal.

Input isolation

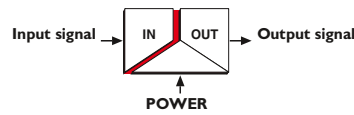

In the case of modules with this isolation method, the electronics connected on the output side (e.g., the controller) are to be protected from interference from the field. For this reason, only the input is electrically isolated from the output and the power supply which are at the same potential.

On the input side, the modules need active signals (e.g., from measurement sensors). On the output side, they provide a filtered and amplified signal (e.g., from the controller).

Repeater power supply

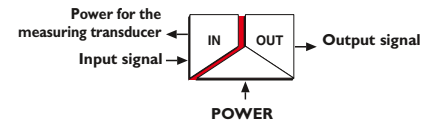

Repeater power supplies use the signal input side not only for measured value acquisition, but also to provide the necessary power to the passive measurement sensors connected on the input side.

On the output side, they provide a filtered and amplified signal (e.g., from the controller).

The isolation method used by these modules is input isolation.

Passive isolation

Passive isolation, supplied on the input side



The modules draw the power needed for signal transmission and electrical isolation from the active input circuit. On the output side, a conditioned current signal is provided to the controller or to actuating elements.

This passive isolation allows signal conditioning (interruption of ground loops) and filtering without an additional power supply.

Passive isolation, supplied on the output side (loop-powered)



The modules draw the power needed for signal transmission and electrical isolation from the active output circuit, ideally from a PLC input card that supplies power.

On the output side, the loop-powered modules operate with a 4 to 20 mA standard signal. On the input side, the passive isolator processes active signals.

When this isolation method is used, it is important to make sure that the active signal source connected on the output side (e.g., an active PLC input card) is able to supply the passive isolator with power, as well as operate its load.

Applications

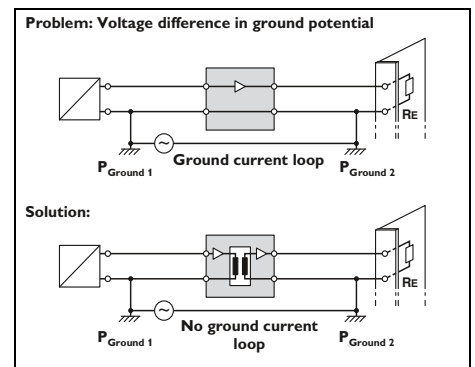
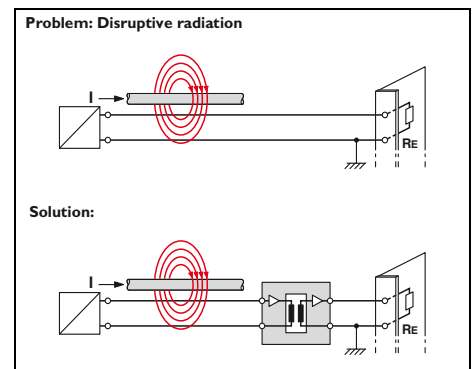

Resistance thermometers

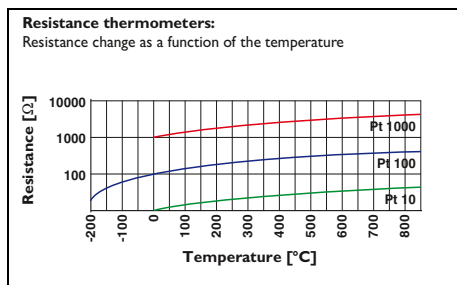

Resistance thermometers (e.g., Pt 100, Ni 1000) change their resistance value depending on the temperature. The measurement and control temperature transducers detect this change and convert it into a proportional analog signal.

To avoid unwanted self-heating of the sensor, the constant measured current used is kept as low as possible (MCR-T-UI... → 250 mA).

Two-conductor connection technology

The resistance thermometer is connected to the measurement and control measuring transducer using a two-wire cable. Please note that the supply cable resistances are added to the measured resistance and consequently distort the result.

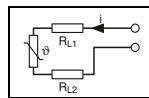

A distance of 10 m should not be exceeded.

Example: a 50 meter long copper cable with a cross section of 0.5 mm² has a specific resistance of 3.4 Ω. A Pt 100 sensor has a resistance change of 0.384 Ω for every 1 K temperature change. This corresponds to an error of 8.8°C.

Three-conductor connection technology

Three-conductor technology is normally used to minimize the effect of cable resistances. An additional cable is connected to the resistance thermometer, so that the latter can be measured using two measuring circuits, one of which acts as a reference. In this way, it is possible to compensate for the cable resistance.

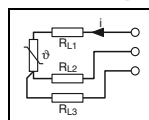

Identical cable lengths and an identical ambient temperature are essential here.

Since this is more or less the case in the majority of applications, three-conductor technology is the most commonly encountered today. Line compensation is not necessary.

Four-conductor connection technology

Four-conductor connection technology is an ideal connection technology for resistance thermometers.

The measurement result is affected neither by cable resistances nor by their temperature-dependent fluctuations. The voltage drop on the supply and return lines can therefore be measured and compensated for separately. Line compensation is not necessary.

Thermocouples

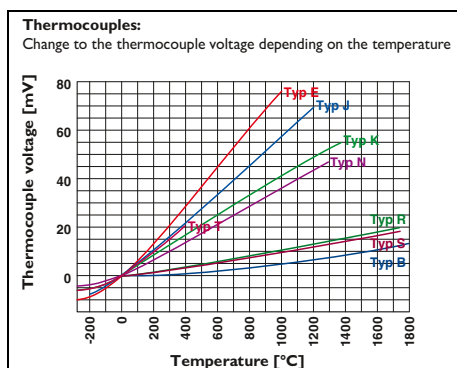

In contrast to resistance thermometers, thermocouples are active sources that generate a voltage in the microvolt range. The temperature difference measured between the measurement junction and the cold junction is converted into an absolute temperature with the help of cold junction compensation.

Operating principle:

If different metals are joined together, a thermal voltage is produced in the metal atoms as a result of the different binding energies of the electrons. This voltage is dependent firstly on the metals themselves and secondly on the temperature.

If the same temperature prevails at the measuring junction (ϑ_1) and the cold junction (ϑ_2), no current will flow because the generated partial voltages cancel each other out. However, if the temperatures at the measuring junction and the cold junction are different, different voltages are produced. These voltages do not completely cancel each other out, and thus current flows.

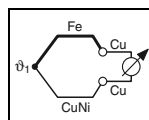

A thermocouple thus always measures only one temperature difference. This is derived from the difference between the thermal voltages at the measuring junction and at the cold junction.

The voltage produced by the thermoelectric effect is very low; only a few microvolts per Kelvin.

Example: if a type J thermocouple (Fe-CuNi) is connected to a copper terminal, thermal voltages with opposite signs will be generated (at the iron-copper and copper-constantan transitions) and cancel each other out.

Therefore, only the difference in the thermal voltages between constantan (Cu-Ni) and iron is of relevance.

The temperature at the terminal point is also significant. If it is known, the temperature at the measuring junction can be derived by adding the thermal voltage measured at the same junction.

The MCR temperature transducers for thermocouples therefore detect the temperature at the terminal points and compensate this value, which is also referred to as the reference junction or the cold junction.

This process is sometimes called cold junction compensation.

Digital displays

Use of the freely programmable characteristic curve

The freely programmable characteristic curve, i.e., the assignment of the displayed value to the input value, is important in process applications for indicating flow rates or liquid levels.

The purpose of level measurements is very often not to determine how much liquid is still inside the tank, but rather to establish how much has been drawn out of it. In this case, the characteristic curve can simply be inverted in order to display the required value.

Parameterization of the characteristic curve using interpolation points

With non-linear input signals, the received analog values can be assigned to the value to be displayed by means of a programmable characteristic curve. This curve can consist of up to 24 interpolation points. This allows flow sensors with a non-linear characteristic curve to be adapted, for instance. The analog signal digital displays in the Function Line additionally feature a summing function which - to take a typical example from bottling technology - allows you to switch over at the touch of a button from the instantaneous value (= flow rate in l/min) to

the total flow integrated in the background, which can be displayed in any unit. This saves space and money, because there is no need for a second digital display.

Limit values can also be called at the touch of a button. Limit values 1 and 2 can be assigned to either the actual value or the cumulative value. If this value is exceeded, one of the two output relays is activated.

Other applications include indicating liquid levels, pressures, and temperatures. With servo motors, the analog output signals (0 to 10 V) generated by the tachometer can be supplied to the input of the digital display in order to indicate the motor speed.

Application:
Pressure measurement and display on MCR-SL-D-U-1

Table:	Analog signal	Display value
Interpolation point 1	4 mA	15 bar
Interpolation point 2	20 mA	30 bar

Characteristic curve:

Switching behavior of relay or transistor outputs:

A different kind of switching behavior can be defined for each relay or each transistor when it reaches a preset switching point.

All the possible settings for the switching behavior are shown and explained in the list:

- The first two options include hysteresis, i.e., the behavior of the relay depends on the direction from which a switching point is reached.
- For the remaining options, with the exception of the last two (“on” and “off”), a switching tolerance is taken into account to prevent the relay contact from “chattering”. The relay is not switched until the switching point plus switching tolerance has been reached.

- In the “on” state, the relay is permanently picked up. It only responds if there is an open circuit and it has been set to drop out when this happens.
- In the “off” state, the relay only responds if there is an open circuit and it has been set to pick up when this happens.

Possible settings for the switching behavior

- Relay picks up when the value is below SPL, hysteresis active
- Relay picks up when SPH is exceeded, hysteresis active
- Relay picks up when the value is below SPL
- Relay picks up when SPL is exceeded
- Relay picks up when the value is below SPH
- Relay picks up when SPH is exceeded
- Relay picks up when value is between SPL and SPH
- Relay picks up when value is outside SPL and SPH
- Relay is constantly in a de-energized state
- Relay is constantly in an energized state

SPL = Set Point Low (lower switching point)
SPH = Set Point High (upper switching point)

Non-intrinsically-safe signal transmission in potentially explosive areas

Electrical equipment operated in systems with potentially explosive areas is subject to different usage requirements, depending on the application.

For example, electrical equipment could be used in the following locations when analog signals are being transmitted:

- Sensors and actuators can be located in Zone 0, Zone 1 or Zone 2.
- Signal transmitters can be located in Zone 1, Zone 2 or the safe area.
- The controller, e.g., PLC, is in the safe area.

For examples of the kinds of electrical devices that can be installed for the purpose of transmitting signals, please see the figure.

Devices must be designed to offer a suitable protection type if they are to be used in Zone 2. The MINI Analog Pro, MINI Analog or MACX Analog ranges are designed to provide “n” protection for this

purpose and must be installed in Zone 2 in suitable and approved housing (EN 60079-15 and EN 60079-0) with at least IP54 protection class.

Example:

A sensor/actuator with protection type “n” can be connected to an isolator from the MINI Analog Pro, MINI Analog or MACX Analog ranges in Zone 2.

When selecting suitable devices for Zone 2, it must be ensured that the electrical data of the sensors and actuators is not exceeded.

If the sensors and actuators are mounted in flameproof enclosure housing or if they have their own flameproof enclosure housing, they can also be installed in Zone 1.

Installation requirements

The figure shows a range of options for installing electrical devices in areas with a danger of gas explosions. Special requirements regarding the configuration, selection, and installation of electrical systems in areas with a danger of gas explosions can be found in EN 60079-14.

In the 2008 edition, relevant content from EN 61241-14 was incorporated in EN 60079-14.

EN 61241-14 must still be observed when installing electrical equipment in areas containing combustible dust. Other important factors when it comes to running systems in potentially explosive areas are inspection, maintenance, and repairs. Specifications regarding these matters can be found in EN 60079-17 and EN 60079-19.

Installation of electrical devices for signal transmission

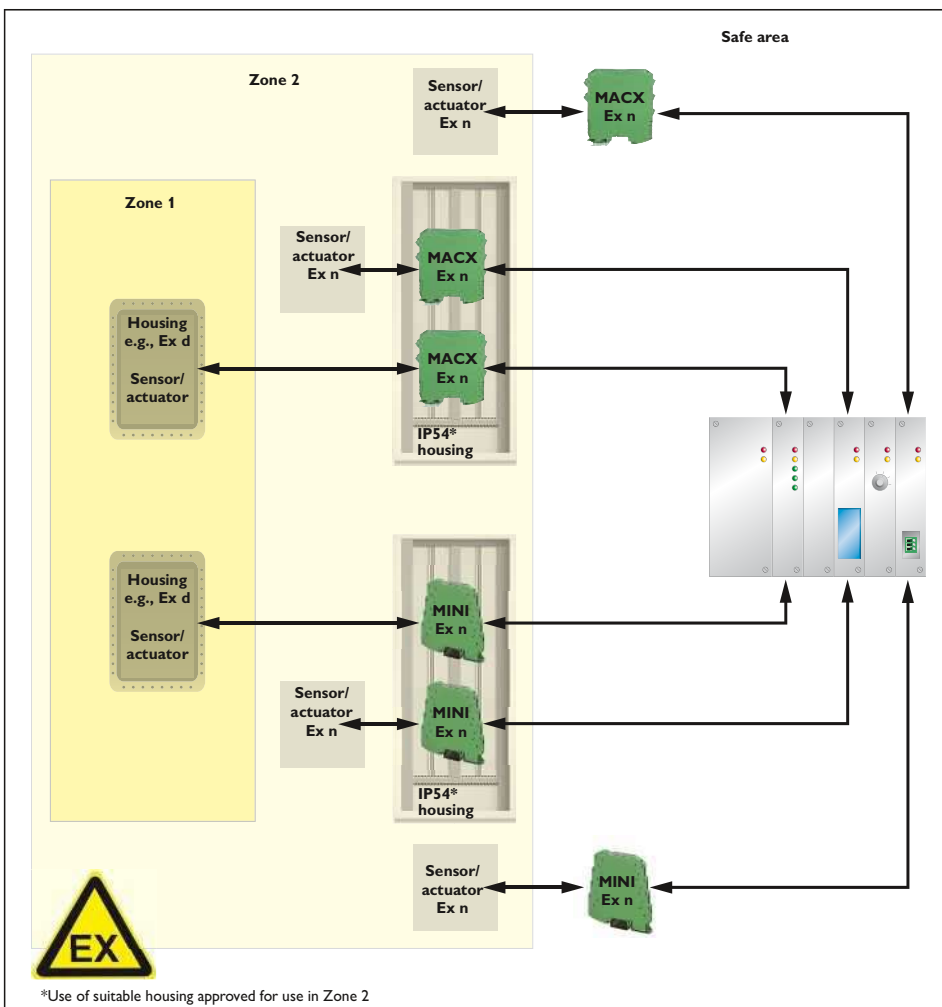

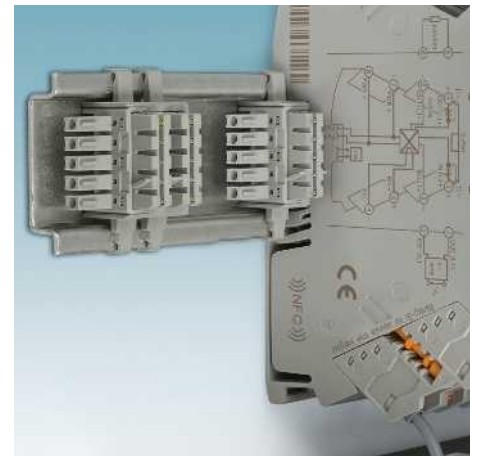
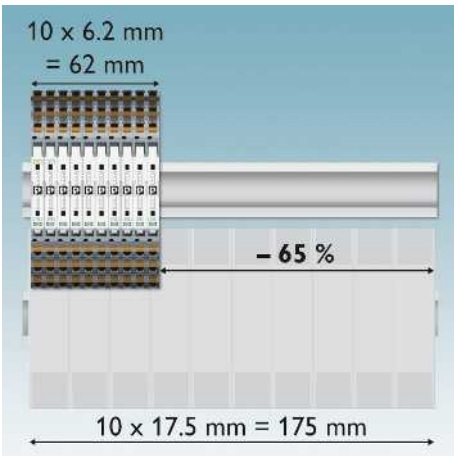
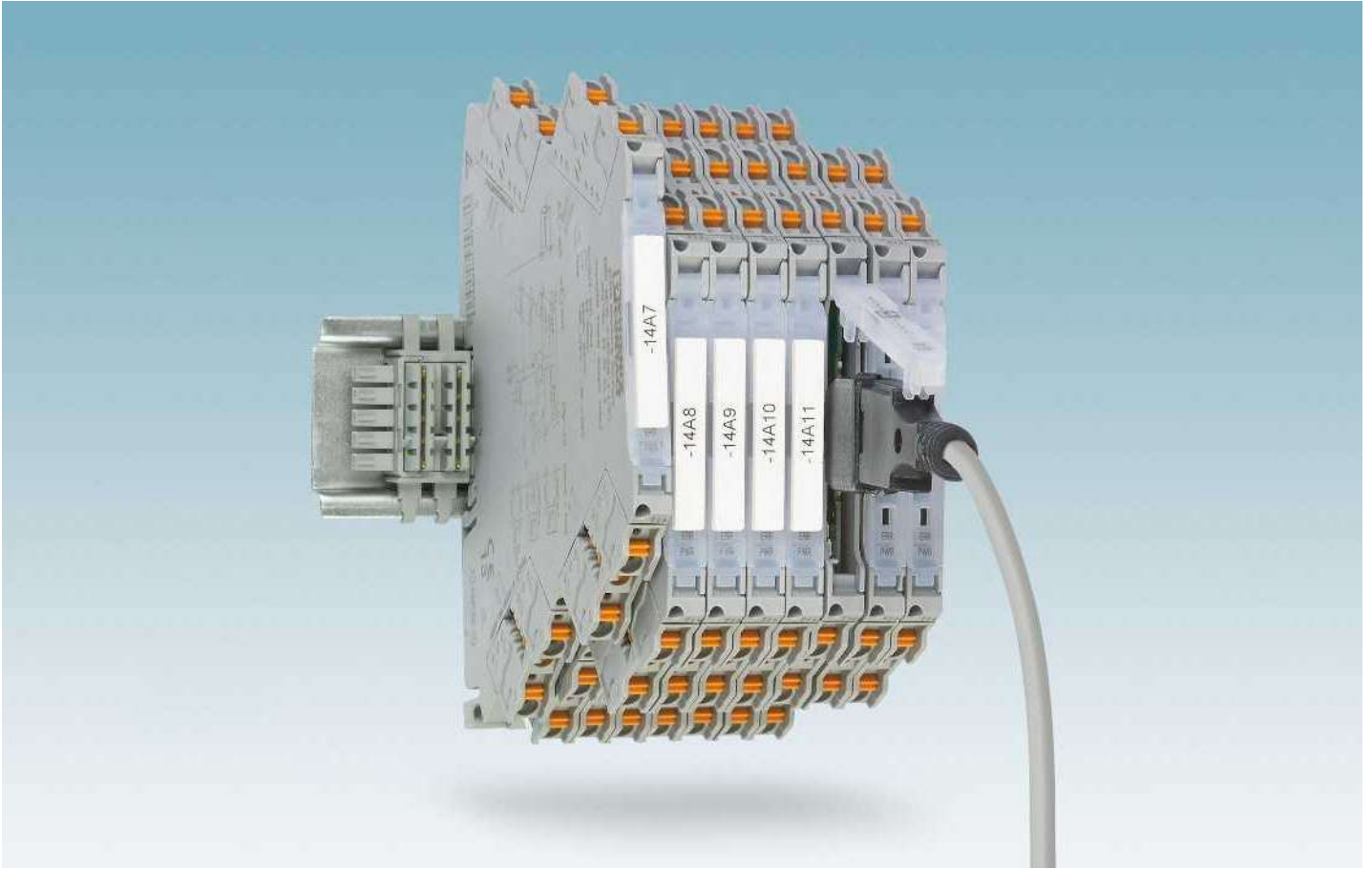

Easier than ever but as slim as before

- MINI Analog Pro offers you the easiest installation and startup in confined spaces.
- Space savings of up to 65%

Select from the following categories

- Analog IN/OUT
- Temperature
- Frequency
- Potentiometers
- Digital IN
- Limit values
- Accessories

Easy installation

- Easily visible and accessible terminal points and FASTCON Pro plug-in connection terminal blocks

Power bridging and fault monitoring

- The DIN rail connector simplifies supply and enables remote diagnostics by means of group error monitoring



DIN-rail-connector-compatible

The DIN rail connector enables modular bridging of the 24 V supply voltage.

Highly compact signal conditioners with plug-in connection technology – MINI Analog Pro



Measure current signals during operation

Measure signals conveniently for startup and servicing during operation, thanks to integrated knife disconnect terminal blocks.

- The circuit does not have to be disconnected in order to integrate the measuring device in the signal circuit
- By setting the connector to the disconnect position, signal circuits can be easily interrupted during servicing and startup



Numerous parameterization options

– Via DIP, PC or smartphone app

App functions via NFC communication



Access to information

- Call module information



DIP switch setting help

- Call module information
- Display DIP switch setting help on the smartphone



Configuration via NFC

- Call module information
- Display DIP switch setting help
- Wireless configuration via smartphone

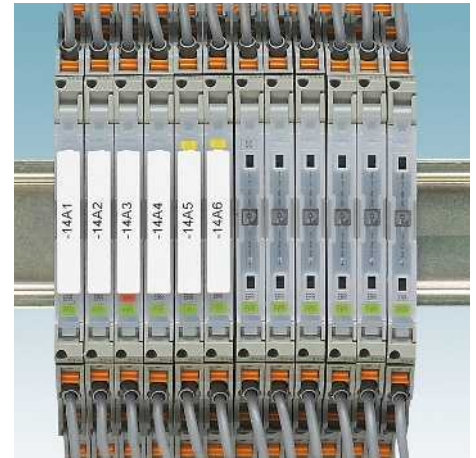

Service-friendly

- Large-surface marking areas for complete loop identification using standard marking material as well as permanently visible status LEDs on each module



Choice of connection technology

- Wiring with screw connection or fast and tool-free with Push-in connection technology



Optimum signal quality

- The latest transmission technology and safe electrical isolation between input, output, and supply with 3 kV test voltage

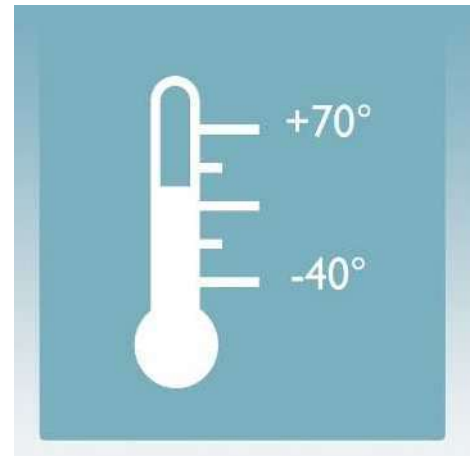

Suitable for any application

- Extended supply voltage and temperature range as well as multifunctional device types

Analog IN/Analog OUT
4-way signal conditioner

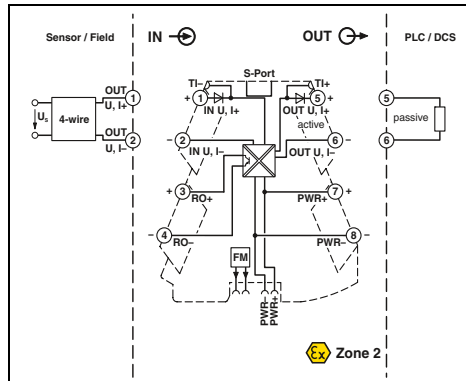
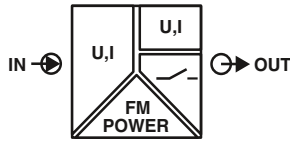

Ex n



Universal 4-way signal conditioner with switching output, configurable



Ex: Ex n

Housing width 6.2 mm

- Universally configurable, highly compact signal conditioner with switching output for electrical isolation, conversion, amplification, and filtering of standard analog signals
- Plug-in connection system
- Safe 4-way isolation
- Standard signal combinations configurable via DIP switches
- Freely configurable with software or smartphone app
- Power supply and fault monitoring possible via DIN rail connector
- Limiting behavior at the output configurable
- Status and error indicator LEDs

Notes:
The configuration software can be downloaded from the Internet: phoenixcontact.net/products .
Information on the programming adapters can be found on page 105
Information on MINI Analog Pro accessories can be found from page 101
To order a product with an order configuration, please enter the desired configuration by referring to the order key.

Input data	Input signal (configurable via DIP switch or freely via software)
Input resistance	> 120 kΩ
Output data	Output signal (configurable via DIP switch or freely via software)
Maximum output signal	Load R_B
Ripple	
Switching output	Relay output Max. switching voltage Maximum switching current
General data	Supply voltage range Nominal supply voltage Current consumption Power consumption
Maximum transmission error	Temperature coefficient Step response (10-90%)
Electrical isolation	Test voltage, input/output/supply Ambient temperature (operation) Dimensions W/H/D EMC note
Conformance/Approvals	Conformance ATEX UL, USA/Canada
GL	

Technical data	
U input	I input
0 V ... 10 V	0 mA ... 20 mA
2 V ... 10 V	4 mA ... 20 mA
0 V ... 5 V	0 mA ... 10 mA
1 V ... 5 V	2 mA ... 10 mA
10 V ... 0 V	20 mA ... 0 mA
10 V ... 2 V	20 mA ... 4 mA
5 V ... 0 V	10 mA ... 0 mA
5 V ... 1 V	10 mA ... 2 mA
0 V ... 12 V	0 mA ... 24 mA
	approx. 50 Ω (+ 0.7 V for test diode)
U output	I output
0 V ... 10 V	0 mA ... 20 mA
2 V ... 10 V	4 mA ... 20 mA
0 V ... 5 V	0 mA ... 10 mA
1 V ... 5 V	2 mA ... 10 mA
0 V ... 10.5 V	0 mA ... 21 mA
approx. 12.3 V	24.6 mA
≥ 10 kΩ	≤ 600 Ω (at 20 mA)
< 20 mV _{pp} (at 600 Ω)	< 20 mV _{pp} (at 600 Ω)
1 N/O contact	
30 V DC	
100 mA (at 30 V)	
U output	I output
9.6 V DC ... 30 V DC	
24 V DC	
32 mA (24 V DC)	63 mA (12 V DC)
	≤ 1 W (at I _{OUT} = 20 mA, 9.6 V DC, 600 Ω load)
0.1 % (of final value)	
0.01 %/K, typ. 0.01 %/K	
approx. 140 ms (15 Hz sample rate)	
approx. 45 ms (60 Hz sample rate)	
approx. 25 ms (240 Hz sample rate)	
Reinforced insulation in accordance with IEC 61010-1	
3 kV (50 Hz, 1 min.)	
-40 °C ... 70 °C	
6.2 / 110.5 / 120.5 mm	
Class A product, see page 605	
CE-compliant	
Ex II 3 G Ex nA IIC T4 Gc X	
UL 508 Listed	
Class I, Div. 2, Groups A, B, C, D T6	
Class I, Zone 2, Group IIC T6	
GL applied for	

Description	Push-in connection	Screw connection
4-way signal conditioner with switching output , for electrical isolation of analog signals		
Standard configuration	Push-in connection	Screw connection
Standard configuration	Screw connection	Push-in connection
Order configuration	Push-in connection	Screw connection
Order configuration	Screw connection	Push-in connection

Programming adapter for configuring modules with S-PORT interface	
Programming adapter for configuring modules with NFC interface	
Bluetooth programming adapter , with USB and S-PORT interface	

Ordering data		
Type	Order No.	Pcs./Pkt.
MINI MCR-2-UNI-UI-UIRO-PT	2902028	1
MINI MCR-2-UNI-UI-UIRO	2902026	1
MINI MCR-2-UNI-UI-UIRO-PT-C	2902027	1
MINI MCR-2-UNI-UI-UIRO-C	2902024	1

Accessories		
Type	Order No.	Pcs./Pkt.
IFS-USB-PROG-ADAPTER	2811271	1
NFC-USB-PROG-ADAPTER	2900013	1
IFS-BT-PROG-ADAPTER	2905872	1

Highly compact signal conditioners with plug-in connection technology – MINI Analog Pro

Order key for MINI MCR-2-UNI-UI-UIRO(-PT)(-C) 4-way signal conditioners (standard configuration entered as an example)

Order No.	Input		Sample rate		Output		Output limitation	
	Input signal	Start	End	Output signal	Start	End		
2902024	I	0.0	20.0	15	I	0.0	20.0	0
2902024 ≙ MINI MCR-2-UNI-UI-UIRO-C	I ≙ I U ≙ U	0.0 ≙ 0 mA I: freely selectable between 0.0 ... 24 mA U: freely selectable between 0.0 ... 12 V	20.0 ≙ 20 mA I: freely selectable between 0.0 ... 24 mA U: freely selectable between 0.0 ... 12 V	15 ≙ 15 Hz 60 ≙ 60 Hz 240 ≙ 240 Hz	I ≙ I U ≙ U	0.0 ≙ 0 mA I: freely selectable between 0.0 ... 21 mA U: freely selectable between 0.0 ... 10.5 V	20.0 ≙ 20 mA I: freely selectable between 0.0 ... 21 mA U: freely selectable between 0.0 ... 10.5 V	0 ≙ OFF 1 ≙ ON
2902027 ≙ MINI MCR-2-UNI-UI-UIRO-PT-C								

Measuring range span at least 0.5 V / 1 mA
Increment 0.1 V / 0.1 mA

Output signal span at least 0.5 V / 1 mA
Increment 0.1 V / 0.1 mA

Failure information

Behavior in the event of an error

Open circuit/short circuit

Measured value overrange

Measured value underrange

NE43DO	0.0	0.0	0.0
FD ≙ Freely definable	0.0 ≙ 0 mA I: freely selectable between 0.0 ... 21.5 mA U: freely selectable between 0.0 ... 11 V (free definition only for unlimited output) (signal type corresponds to selected output signal)	0.0 ≙ 0 mA I: freely selectable between 0.0 ... 21.5 mA U: freely selectable between 0.0 ... 11 V (free definition only for unlimited output) (signal type corresponds to selected output signal)	0.0 ≙ 0 mA I: freely selectable between 0.0 ... 21.5 mA U: freely selectable between 0.0 ... 11 V (free definition only for unlimited output) (signal type corresponds to selected output signal)
Note: Failure information according to NE 43 can only be selected for 4 ... 20 mA output			
NE43UP ≙ NE 43 upscale NE43DO ≙ NE 43 downscale NE430 ≙ NE 43 0 mA NE43UD ≙ NE 43 upscale/downscale	21.5 mA 3.5 mA 0 mA 3.5 mA	21.5 mA 3.5 mA 0 mA 21.5 mA	21.5 mA 3.5 mA 0 mA 21.5 mA

Analog IN/Analog OUT
3-way signal conditioner

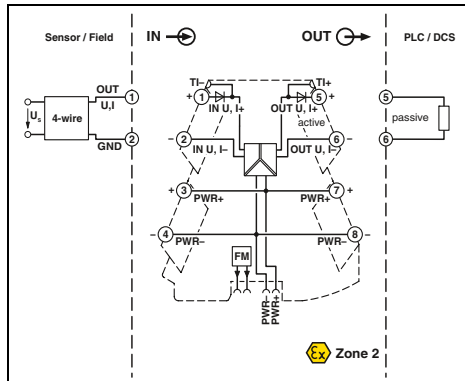
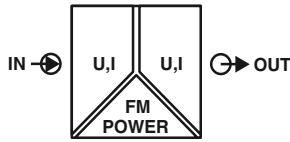

Ex n



3-way signal conditioner for standard signals, configurable

Housing width 6.2 mm

- Configurable, ultra-compact signal conditioner for electrical isolation, conversion, amplification, and filtering of standard analog signals
- Plug-in connection system
- Safe 3-way isolation
- Standard signal combinations configurable via DIP switches
- Power supply and fault monitoring possible via DIN rail connector
- Status LED

Notes:
Information on MINI Analog Pro accessories can be found from page 101
To order a product with an order configuration, please enter the desired configuration by referring to the order key.

Input data	Input signal (configurable using the DIP switch)
Output data	Output signal (configurable using the DIP switch)
Maximum output signal	No-load voltage Short-circuit current Load R_B Ripple
General data	Supply voltage range Nominal supply voltage Current consumption
Power consumption	
Maximum transmission error	Temperature coefficient Limit frequency (3 dB) Step response (10-90%) Electrical isolation Test voltage, input/output/supply Degree of protection Ambient temperature (operation) Mounting Housing material Dimensions W/H/D Push-in connection solid/stranded/AWG Screw connection solid/stranded/AWG EMC note
Conformance/Approvals	Conformance ATEX UL, USA/Canada
DNV GL	

Technical data	
U input	I input
0 V ... 5 V	0 mA ... 20 mA
1 V ... 5 V	4 mA ... 20 mA
-5 V ... 5 V	-20 mA ... 20 mA
0 V ... 10 V	
2 V ... 10 V	
-10 V ... 10 V	
0 V ... 20 V	
4 V ... 20 V	
-20 V ... 20 V	
0 V ... 24 V	
4.8 V ... 24 V	
-24 V ... 24 V	
0 V ... 30 V	
6 V ... 30 V	
-30 V ... 30 V	
> 1000 k Ω	approx. 63 Ω (+ 0.7 V for test diode)
U output	I output
0 V ... 5 V	0 mA ... 20 mA
1 V ... 5 V	4 mA ... 20 mA
-5 V ... 5 V	
0 V ... 10 V	
2 V ... 10 V	
-10 V ... 10 V	
	22 mA
	< 17 V
< 32 mA	
≥ 10 k Ω	≤ 600 Ω (at 20 mA)
< 20 mV _{pp} (at 600 Ω)	< 20 mV _{pp} (at 600 Ω)
U output	I output
9.6 V DC ... 30 V DC	
24 V DC	
25 mA (Current output, at 24 V DC incl. load)	54 mA (Current output, at 12 V DC incl. load)
	≤ 800 mW (at $I_{OUT} = 20$ mA, 9.6 V DC, 600 Ω load)
≤ 0.1 % (of final value)	
0.01 %/K, typ. 0.01 %/K	
30 Hz (via DIP switch)	
< 8.5 ms (with 30 Hz filter)	
Reinforced insulation in accordance with IEC 61010-1	
3 kV (50 Hz, 1 min.)	
IP20	
-40 °C ... 70 °C	
any	
PBT	
6.2 / 110.5 / 120.5 mm	
0.14 ... 2.5 mm ² / 0.14 ... 2.5 mm ² / 24 - 12	
0.2 ... 1.5 mm ² / 0.2 ... 1.5 mm ² / 24 - 12	
Class A product, see page 605	
CE-compliant	
II 3 G Ex nA IIC T4 Gc X	
UL 508 Listed	
Class I, Div. 2, Groups A, B, C, D T6	
Class I, Zone 2, Group IIC T6	
C, EMC2	

Ordering data		
Type	Order No.	Pcs./Pkt.
MINI MCR-2-UI-UI-PT	2902040	1
MINI MCR-2-UI-UI	2902037	1
MINI MCR-2-UI-UI-PT-C	2902039	1
MINI MCR-2-UI-UI-C	2902036	1

Highly compact signal conditioners with plug-in connection technology – MINI Analog Pro

Order key for MINI MCR-2-UI-UI(-PT)(-C) 3-way signal conditioners (standard configuration entered as an example)

Order No. Input Output Cut-off frequency

2902036	IN03	OUT01	5K
2902036 ≙ MINI MCR-2- UI-UI-C	IN 01 ≙ 0 ... 20 mA IN 02 ≙ 4 ... 20 mA IN 03 ≙ 0 ... 10 V IN 04 ≙ 2 ... 10 V IN 05 ≙ 0 ... 5 V IN 06 ≙ 1 ... 5 V IN 21 ≙ -5 ... 5 V IN 22 ≙ -10 ... 10 V IN 23 ≙ -20 ... 20 V IN 32 ≙ 0 ... 20 V IN 35 ≙ -20 ... 20 mA IN 38 ≙ 0 ... 24 V IN 39 ≙ 0 ... 30 V IN 80 ≙ -30 ... 30 V IN 93 ≙ -24 ... 24 V IN 94 ≙ 4.8 ... 24 V IN 95 ≙ 6 ... 30 V IN 96 ≙ 4 ... 20 V	OUT 01 ≙ 0 ... 20 mA OUT 02 ≙ 4 ... 20 mA OUT 03 ≙ 0 ... 10 V OUT 04 ≙ 2 ... 10 V OUT 05 ≙ 0 ... 5 V OUT 06 ≙ 1 ... 5 V OUT 13 ≙ -5 ... 5 V OUT 14 ≙ -10 ... 10 V	30 Hz 5 kHz
2902039 ≙ MINI MCR-2- UI-UI-PT-C			

Signal combinations for MINI MCR-2-UI-UI(-PT)(-C) signal conditioners

Input	Output							
	0 ... 20 mA	4 ... 20 mA	0 ... 5 V	1 ... 5 V	-5 ... 5 V	0 ... 10 V	2 ... 10 V	-10 ... 10 V
0 ... 20 mA	X	X	X	X	X	X	X	X
4 ... 20 mA	X	X	X	X	X	X	X	X
-20 ... 20 mA	X	X	X	X	X	X	X	X
0 ... 5 V	X	X	X	X	X	X	X	X
1 ... 5 V	X	X	X	X	X	X	X	X
-5 ... 5 V	X	X	X	X	X	X	X	X
0 ... 10 V	X	X	X	X	X	X	X	X
2 ... 10 V	X	X	X	X	X	X	X	X
-10 ... 10 V	X	X	X	X	X	X	X	X
0 ... 20 V	X	X	X	X	X	X	X	X
4 ... 20 V	X	X	X	X	X	X	X	X
-20 ... 20 V	X	X	X	X	X	X	X	X
0 ... 24 V	X	X	X	X	X	X	X	X
4.8 ... 24 V	X	X	X	X	X	X	X	X
-24 ... 24 V	X	X	X	X	X	X	X	X
0 ... 30 V	X	X	X	X	X	X	X	X
6 ... 30 V	X	X	X	X	X	X	X	X
-30 ... 30 V	X	X	X	X	X	X	X	X

Analog IN/Analog OUT
3-way signal conditioner

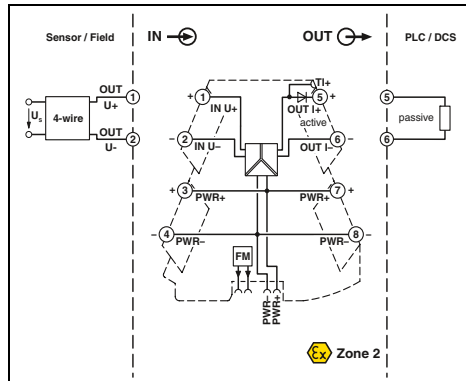
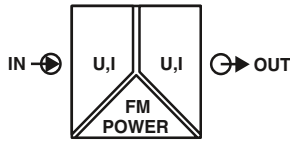

3-way signal conditioner with fixed signal combinations

- Highly compact signal conditioner for electrical isolation, conversion, amplification, and filtering of standard analog signals
- Fixed signal combinations
- Plug-in connection system
- Safe 3-way isolation
- Power supply and fault monitoring possible via DIN rail connector
- Status LED

Notes:
Information on MINI Analog Pro accessories can be found from page 101

Input data	Input resistance
Output data	Maximum output signal No-load voltage Short-circuit current Load R_B Ripple
General data	Supply voltage U_B Nominal supply voltage Typ. current consumption Maximum transmission error Temperature coefficient Limit frequency (3 dB) Step response (10-90%) Degree of protection Electrical isolation Test voltage, input/output/supply Ambient temperature (operation) Housing material Dimensions W/H/D Push-in connection solid/stranded/AWG Screw connection solid/stranded/AWG EMC note
Conformance/Approvals	Conformance ATEX UL, USA/Canada

DNV GL

Technical data	
U input	I input
approx. 1 M Ω	approx. 63 Ω (+ 0.7 V for test diode)
U output	I output
11 V	22 mA < 17 V
< 15 mA	
≥ 10 k Ω	≤ 600 Ω (at 20 mA)
< 20 mV _{pp} (at 10 k Ω)	< 20 mV _{pp} (at 600 Ω)
General data	
9.6 V DC ... 30 V DC 24 V DC 25 mA (24 V DC) 0.1 % (of final value) 0.01 %/K, typ. 0.01 %/K approx. 30 Hz approx. 10 ms IP20 Reinforced insulation in accordance with IEC 61010-1 3 kV (50 Hz, 1 min.) -40 °C ... 70 °C PBT 6.2 / 110.5 / 120.5 mm 0.14 ... 2.5 mm ² / 0.14 ... 2.5 mm ² / 24 - 12 0.2 ... 1.5 mm ² / 0.2 ... 1.5 mm ² / 24 - 12 Class A product, see page 605	
Conformance/Approvals	
CE-compliant Ex II 3 G Ex nA IIC T4 Gc X UL 508 Listed Class I, Div. 2, Groups A, B, C, D T6 Class I, Zone 2, Group IIC T6 C, EMC2	

Ordering data		
Type	Order No.	Pcs./Pkt.
3-way signal conditioner, for electrical isolation of analog signals		
Push-in connection	0 ... 10 V / 0 ... 20 mA	1
Screw connection	0 ... 10 V / 0 ... 20 mA	1
Push-in connection	0 ... 10 V / 4 ... 20 mA	1
Screw connection	0 ... 10 V / 4 ... 20 mA	1
Push-in connection	0 ... 20 mA / 0 ... 10 V	1
Screw connection	0 ... 20 mA / 0 ... 10 V	1
Push-in connection	4 ... 20 mA / 0 ... 10 V	1
Screw connection	4 ... 20 mA / 0 ... 10 V	1
Push-in connection	0 ... 20 mA, 4 ... 20 mA / 0 ... 20 mA, 4 ... 20 mA	1
Screw connection	0 ... 20 mA, 4 ... 20 mA / 0 ... 20 mA, 4 ... 20 mA	1
Push-in connection	0 ... 10 V, -10 ... 10 V / 0 ... 10 V, -10 ... 10 V	1
Screw connection	0 ... 10 V, -10 ... 10 V / 0 ... 10 V, -10 ... 10 V	1

Analog IN/Analog OUT
3-way repeater power supply

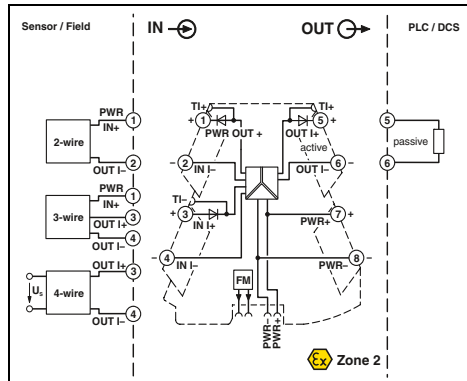
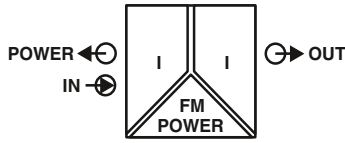

Ex n



3-way repeater power supply



Housing width 6.2 mm

Technical data

Input data

Input signal

Input resistance
Transmitter supply voltage

Output data

Output signal
Maximum output signal
No-load voltage
Load R_B
Ripple

General data

Supply voltage range
Nominal supply voltage
Current consumption
Power consumption

Maximum transmission error

Temperature coefficient
Limit frequency (3 dB)
Step response (10-90%)

Electrical isolation

Test voltage, input/output/supply
Degree of protection
Ambient temperature (operation)

Mounting
Housing material
Dimensions W/H/D

Push-in connection solid/stranded/AWG

Screw connection solid/stranded/AWG

EMC note

Conformance/Approvals

Conformance
ATEX
UL, USA/Canada

DNV GL

0 ... 20 mA , isolator operation /
4 ... 20 mA , repeater power supply and isolator operation
approx. 68 Ω (+ 0.7 V for test diode)
> 19.5 V

0 ... 20 mA / 4 ... 20 mA
24 mA
< 20 V
≤ 600 Ω (at 20 mA)
< 20 mV_{PP} (at 600 Ω)

9.6 V DC ... 30 V DC
24 V DC
25 mA (at 24 V DC and in isolator operation)
≤ 1400 mW (at I_{OUT} = 20 mA, 9.6 V DC, 600 Ω load)

0.1 % (of final value)
0.01 %/K, typ. 0.01 %/K
> 1.75 kHz (typ.)
< 200 μs (typ.)

Reinforced insulation in accordance with IEC 61010-1
3 kV (50 Hz, 1 min.)
IP20
-40 °C ... 70 °C

any
PBT
6.2 / 110.5 / 120.5 mm
0.14 ... 2.5 mm² / 0.14 ... 2.5 mm² / 24 - 12
0.2 ... 1.5 mm² / 0.2 ... 1.5 mm² / 24 - 12
Class A product, see page 605

CE-compliant
Ex II 3 G Ex nA IIC T4 Gc X
UL 508 Listed
Class I, Div. 2, Groups A, B, C, D T5
Class I, Zone 2, Group IIC T5
C, EMC2

Ordering data

Description

3-way repeater power supply

Push-in connection
Screw connection

Type

MINI MCR-2-RPSS-I-I-PT
MINI MCR-2-RPSS-I-I

Order No.

2902015
2902014

Pcs./Pkt.

1
1

- Highly compact repeater power supply for electrical isolation, conversion, amplification, and filtering of standard analog signals
- Supply of 2-wire and passive 3-wire sensors
- Can also be used as an isolator without supply
- Plug-in connection system
- Safe 3-way isolation
- Power supply and fault monitoring possible via DIN rail connector
- Status LED

Notes:

Information about power bridging, system cabling, and marking components can be found from page 98

Analog IN/Analog OUT
4-way signal duplicator

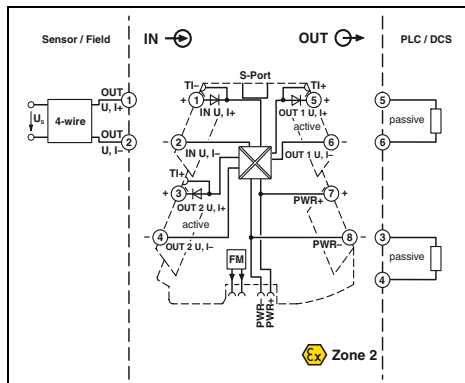
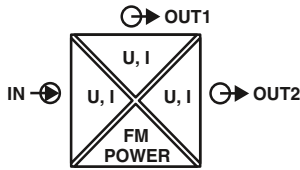

4-way signal duplicator



Housing width 6.2 mm

- Universally configurable, highly compact 4-way signal duplicator
- For electrical isolation, conversion, amplification, and filtering of standard signals
- Independently adjustable outputs
- Input side for current signals from 0 to 24 mA or voltage signals from 0 to 12 V
- Supports fault monitoring
- Plug-in connection system
- Safe 4-way isolation
- Standard behavior can be configured via DIP switches
- Freely configurable via software or smartphone app
- Power supply and fault monitoring possible via DIN rail connector
- Status and error indicator LEDs

Notes:
To order a product with an order configuration, enter the required configuration by referring to the adjacent order key.

Input data
Input signal (configurable via DIP switch or freely via software)
Maximum input signal
Input resistance
Output data
Output signal (configurable via DIP switch or freely via software)
Maximum output signal
No-load voltage
Short-circuit current
Load R_B
Ripple
General data
Supply voltage range
Nominal supply voltage
Current consumption
Power consumption
Maximum transmission error
Temperature coefficient
Step response (10-90%)
Electrical isolation
Test voltage, input/output/supply
Degree of protection
Ambient temperature (operation)
Mounting
Housing material
Dimensions W/H/D
Push-in connection solid/stranded/AWG
Screw connection solid/stranded/AWG
EMC note
Conformance/Approvals
Conformance
ATEX
UL, USA/Canada
GL

Technical data	
U input	I input
0 V ... 10 V	0 mA ... 20 mA
2 V ... 10 V	4 mA ... 20 mA
0 V ... 5 V	0 mA ... 10 mA
1 V ... 5 V	20 mA ... 0 mA
0 V ... 12 V	0 mA ... 24 mA
12 V	24 mA
> 120 kΩ	approx. 50 Ω (+ 0.7 V for test diode)
U output	I output
0 V ... 10 V	0 mA ... 20 mA
2 V ... 10 V	4 mA ... 20 mA
0 V ... 5 V	0 mA ... 10 mA
1 V ... 5 V	20 mA ... 0 mA
0 V ... 10.5 V	0 mA ... 21 mA
approx. 12.3 V	24.6 mA
≤ 25 mA	≤ 18.5 V
≥ 10 kΩ	≤ 600 Ω (per channel)
< 20 mV _{PP} (at 600 Ω)	< 20 mV _{PP} (at 600 Ω)
U output	I output
9.6 V DC ... 30 V DC	
24 V DC	
55 mA (24 V DC)	110 mA (12 V DC)
	1.5 W (at I _{OUT} = 20 mA, 9.6 V DC, 600 Ω load)
0.1 % (of final value)	
0.01 %/K	
approx. 140 ms (15 Hz sample rate)	
approx. 45 ms (60 Hz sample rate)	
approx. 25 ms (240 Hz sample rate)	
Reinforced insulation in accordance with IEC 61010-1	
3 kV (50 Hz, 1 min.)	
IP20	
-40 °C ... 70 °C	
any	
PBT	
6.2 / 110.5 / 120.5 mm	
0.14 ... 2.5 mm ² / 0.14 ... 2.5 mm ² / 24 - 12	
0.2 ... 1.5 mm ² / 0.2 ... 1.5 mm ² / 24 - 12	
Class A product, see page 605	
CE-compliant	
Ex II 3 G Ex nA IIC T4 Gc X	
UL 508 Listed	
Class I, Div. 2, Groups A, B, C, D T6	
Class I, Zone 2, Group IIC T6	
GL applied for	

Description	
4-way signal duplicator , with independently adjustable outputs	
Standard configuration	Push-in connection
Standard configuration	Screw connection
Order configuration	Push-in connection
Order configuration	Screw connection

Programming adapter for configuring modules with S-PORT interface
Programming adapter for configuring modules with NFC interface
Bluetooth programming adapter , with USB and S-PORT interface

Ordering data		
Type	Order No.	Pcs./ Pkt.
MINI MCR-2-UNI-UI-2UI-PT	2905028	1
MINI MCR-2-UNI-UI-2UI	2905026	1
MINI MCR-2-UNI-UI-2UI-PT-C	2905027	1
MINI MCR-2-UNI-UI-2UI-C	2905025	1

Accessories		
IFS-USB-PROG-ADAPTER	2811271	1
NFC-USB-PROG-ADAPTER	2900013	1
IFS-BT-PROG-ADAPTER	2905872	1

Highly compact signal conditioners with plug-in connection technology – MINI Analog Pro

Order key for MINI MCR-2-UNI-UI-2UI(-PT)(-C) 4-way signal duplicators (standard configuration entered as an example)

Order No.	Input			Output		Output limitation
	Input signal	Start	End	Output 1	Output 2	
2905025	I	0.0	20.0	I	0.0	0
2905025 ≙ MINI MCR-2-UNI-UI-2UI-C	I ≙ I U ≙ U	0.0 ≙ 0 mA I: freely selectable between 0.0 ... 24 mA	20.0 ≙ 20 mA I: freely selectable between 0.0 ... 24 mA	OUT01 ≙ 0 ... 20 mA OUT02 ≙ 4 ... 20 mA OUT03 ≙ 0 ... 10 V OUT04 ≙ 2 ... 10 V OUT05 ≙ 0 ... 5 V OUT06 ≙ 1 ... 5 V OUT16 ≙ 0 ... 10 mA OUT07 ≙ 20 ... 0 mA OUT08 ≙ 20 ... 4 mA	OUT01 ≙ 0 ... 20 mA OUT02 ≙ 4 ... 20 mA OUT03 ≙ 0 ... 10 V OUT04 ≙ 2 ... 10 V OUT05 ≙ 0 ... 5 V OUT06 ≙ 1 ... 5 V OUT16 ≙ 0 ... 10 mA OUT07 ≙ 20 ... 0 mA OUT08 ≙ 20 ... 4 mA	0 ≙ OFF 1 ≙ ON
2905027 ≙ MINI MCR-2-UNI-UI-2UI-PT-C		U: freely selectable between 0.0 ... 12 V	U: freely selectable between 0.0 ... 12 V			

Measuring range span at least 0.5 V / 1 mA
Increment 0.1 V / 0.1 mA

Output signal span at least 0.5 V / 1 mA
Increment 0.1 V / 0.1 mA

Analog IN/Analog OUT 2-way passive isolator, input loop-powered

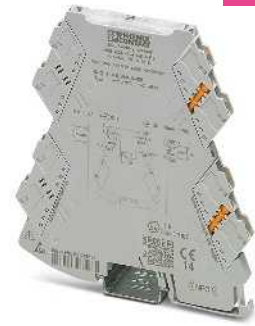
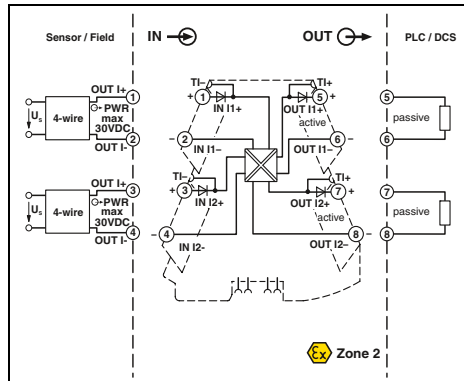
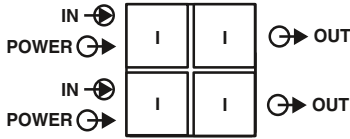

Either 1 or 2-channel



Housing width 6.2 mm

- Highly compact 2-way repeater power supply
- Input loop-powered
- Does not require any additional auxiliary voltage
- For electrical isolation and filtering of analog signals
- Powered via the current loop of the sensor
- Input signal = output signal 0(4) to 20 mA
- Plug-in connection system
- Status LED

Notes:

Information on MINI Analog Pro accessories can be found from page 101

Input data

Input signal
Input voltage limitation
Voltage drop
Response current

Output data

Output signal
Load R_B
Transmission behavior

General data

Maximum transmission error
Additional error per 100 Ω load
Temperature coefficient
Limit frequency (3 dB)
Electrical isolation
Test voltage, input/output/supply
Degree of protection
Ambient temperature (operation)
Mounting
Housing material
Dimensions W/H/D
Push-in connection solid/stranded/AWG
Screw connection solid/stranded/AWG

Conformance/Approvals

Conformance
ATEX
UL, USA/Canada

GL

Technical data

0 ... 20 mA / 4 ... 20 mA
30 V
3.1 V ($I = 20$ mA)
approx. 200 μ A

0 ... 20 mA / 4 ... 20 mA
< 600 Ω (at $I = 20$ mA output signal)
1:1 to input signal

≤ 0.1 % (of final value)
< 0.075 % (of measured value / 100 Ω load)
 ≤ 0.002 %/K (of measured value / 100 Ω load)
100 Hz
Reinforced insulation in accordance with IEC 61010-1
3 kV (50 Hz, 1 min.)
IP20
-40 °C ... 70 °C
any
PBT
6.2 / 110.5 / 120.5 mm
0.14 ... 2.5 mm² / 0.14 ... 2.5 mm² / 24 - 12
0.2 ... 1.5 mm² / 0.2 ... 1.5 mm² / 24 - 12

CE-compliant
Ex II 3 G Ex nA IIC T4 Gc X
UL 508 Listed
Class I, Div. 2, Groups A, B, C, D T6
Class I, Zone 2, Group IIC T6
GL applied for

Ordering data

Description

Input loop-powered 2-way isolator, for isolating current signals without auxiliary power

single-channel	Push-in connection	MINI MCR-2-I-I-ILP-PT
single-channel	Screw connection	MINI MCR-2-I-I-ILP
two-channel	Push-in connection	MINI MCR-2-2I-2I-ILP-PT
two-channel	Screw connection	MINI MCR-2-2I-2I-ILP

Type	Order No.	Pcs./Pkt.
MINI MCR-2-I-I-ILP-PT	2901995	1
MINI MCR-2-I-I-ILP	2901994	1
MINI MCR-2-2I-2I-ILP-PT	2901997	1
MINI MCR-2-2I-2I-ILP	2901996	1

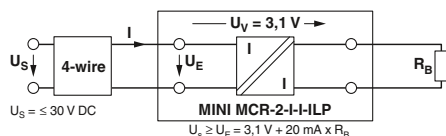

Analog IN/Analog OUT
2-way passive isolator,
output loop-powered

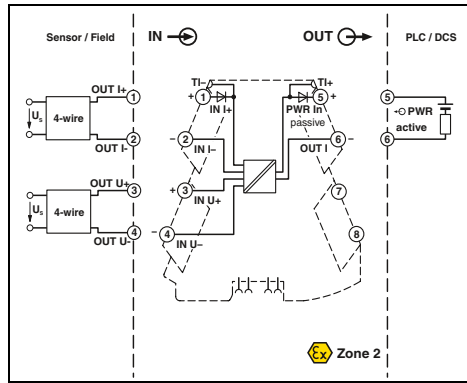
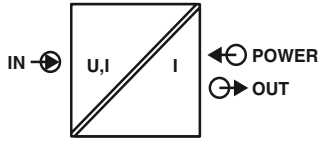

Configurable,
up to 74 signal combinations



Housing width 6.2 mm

- Highly compact passive isolator for electrical isolation and filtering of standard analog signals
- Safe 2-way isolation
- Output loop-powered
- Does not require any additional auxiliary voltage
- Up to 74 signal combinations can be configured using DIP switches
- Plug-in connection system
- Voltage input from mV voltages up to 30 V
- Current input from 2 to 40 mA
- Status LED

Notes:

To order a product with an order configuration, please enter the desired configuration by referring to the order key.

Information on MINI Analog Pro accessories can be found from page 101

Input data

Input signal (configurable using the DIP switch)

Maximum input signal
 Input resistance

Output data

Output signal
 Maximum output signal
 Load R_B
 Ripple

General data

Current consumption
 Maximum transmission error
 Temperature coefficient
 Limit frequency (3 dB)
 Step response (10-90%)
 Electrical isolation
 Test voltage, input/output/supply
 Degree of protection
 Ambient temperature (operation)
 Housing material
 Dimensions W/H/D
 Push-in connection solid/stranded/AWG
 Screw connection solid/stranded/AWG
 EMC note
 Conformance/Approvals
 Conformance
 ATEX
 UL, USA/Canada

U input

2 ... 10 V, additional areas can be configured, see table

< 30 V
 approx. 100 k Ω (At \leq 1 V,
 otherwise approximately 1 M Ω)

I input

50 mA (Dielectric strength up to 30 V)
 25 Ω (+ 0.7 V for test diode)

4 ... 20 mA

32 mA
 ($U_B - 8$ V) / 22 mA
 < 10 mV_{rms} (at 600 Ω)

≤ 20 mA

≤ 0.1 % (of final value)
 0.01 %/K, typ. 0.005 %/K
 approx. 30 Hz
 20 ms

Reinforced insulation in accordance with IEC 61010-1

3 kV (50 Hz, 1 min.)

IP20

-40 °C ... 70 °C

PBT

6.2 / 110.5 / 120.5 mm

0.14 ... 2.5 mm² / 0.14 ... 2.5 mm² / 24 - 12

0.2 ... 1.5 mm² / 0.2 ... 1.5 mm² / 24 - 12

Class A product, see page 605

CE-compliant

Ex II 3 G Ex nA IIC T4 Gc X

UL 508 Listed

Class I, Div. 2, Groups A, B, C, D T5

Class I, Zone 2, Group IIC T5

Ordering data

Description	Type	Order No.	Pcs./Pkt.
Output loop-powered 2-way isolator, for isolating current signals without auxiliary power			
Standard configuration Push-in connection	MINI MCR-2-UI-I-OLP-PT	2902063	1
Standard configuration Screw connection	MINI MCR-2-UI-I-OLP	2902061	1
Order configuration Push-in connection	MINI MCR-2-UI-I-OLP-PT-C	2902062	1
Order configuration Screw connection	MINI MCR-2-UI-I-OLP-C	2902060	1

Order key for MINI MCR-2-UI-I-OLP-(PT)-(C)

Order No.	Input	Output
2902060	0 mV ... 1000 mV	
2902060 ≙	0 mV ... 1000 mV	0 V ... 10 V -1000 mV ... 1000 mV -10 V ... 10 V 0 mA ... 40 mA -2 mA ... 2 mA
MINI MCR-2-UI-I-OLP-C	0 mV ... 750 mV	0 V ... 7.5 V -750 mV ... 750 mV -7.5 V ... 7.5 V 0 mA ... 30 mA -3 mA ... 3 mA
	0 mV ... 500 mV	0 V ... 5 V -500 mV ... 500 mV -5 V ... 5 V 0 mA ... 20 mA -10 mA ... 10 mA
	0 mV ... 300 mV	0 V ... 3 V -300 mV ... 300 mV -3 V ... 3 V 0 mA ... 12 mA -15 mA ... 15 mA
2902062 ≙	0 mV ... 250 mV	0 V ... 2.5 V -250 mV ... 250 mV -2.5 V ... 2.5 V 0 mA ... 10 mA -20 mA ... 20 mA
MINI MCR-2-UI-I-OLP-PT-C	0 mV ... 200 mV	0 V ... 2 V -200 mV ... 200 mV -2 V ... 2 V 0 mA ... 8 mA -30 mA ... 30 mA
	0 mV ... 150 mV	0 V ... 1.5 V -125 mV ... 125 mV -1.25 V ... 1.25 V 0 mA ... 7.5 mA -40 mA ... 40 mA
	0 mV ... 125 mV	0 V ... 1.25 V -120 mV ... 120 mV -1.2 V ... 1.2 V 0 mA ... 5 mA
	0 mV ... 120 mV	0 V ... 1.2 V -150 mV ... 150 mV -1.5 V ... 1.5 V 0 mA ... 6 mA
	0 mV ... 100 mV	0 V ... 30 V -100 mV ... 100 mV -30 V ... 30 V 0 mA ... 4 mA
	0 mV ... 75 mV	0 V ... 25 V -75 mV ... 75 mV -25 V ... 25 V 0 mA ... 3 mA
	0 mV ... 60 mV	0 V ... 20 V -60 mV ... 60 mV -20 V ... 20 V 0 mA ... 2.5 mA
	0 mV ... 50 mV	0 V ... 12.5 V -50 mV ... 50 mV -12.5 V ... 12.5 V 0 mA ... 2 mA
		0 V ... 12 V -12 V ... 12 V 4 mA ... 20 mA
		0 V ... 15 V -15 V ... 15 V 2 mA ... 10 mA
		2 V ... 10 V 1 V ... 5 V 1 mA ... 5 mA

Temperature
Temperature transducer
for resistance thermometers

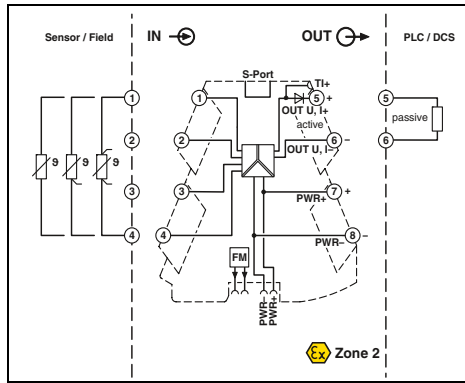
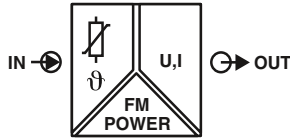

Universal temperature transducer
for resistance thermometers



Housing width 6.2 mm

- Universally configurable, highly compact temperature transducer for electrical isolation, conversion, amplification, and filtering of resistance thermometer and remote resistance-type sensor signals
- For 2, 3 or 4-wire sensors according to IEC 751, JIS, GOST

- Plug-in connection system
- Safe 3-way isolation
- Standard signal combinations configurable via DIP switches
- Freely configurable with software or smartphone app
- Power supply and fault monitoring possible via DIN rail connector
- Status and error indicator LEDs

Notes:
The configuration software can be downloaded from the Internet: phoenixcontact.net/products .
Information on the programming adapters can be found on page 105
Information on MINI Analog Pro accessories can be found from page 101
To order a product with an order configuration, please enter the desired configuration by referring to the order key.

Input data
Input signal (can be configured using DIP switches) Temperature range
Measuring range span Linear resistance measuring range
Output data
Output signal (configurable via DIP switch or freely via software)
Maximum output signal No-load voltage Short-circuit current Load R_B Ripple
General data
Supply voltage range Current consumption Power consumption
Transmission error
Temperature coefficient Step response (0–99%)
Electrical isolation Test voltage, input/output/supply Ambient temperature (operation) Housing material Dimensions W/H/D Push-in connection solid/stranded/AWG Screw connection solid/stranded/AWG EMC note
Conformance/Approvals
Conformance ATEX UL, USA/Canada
DNV GL

Technical data	
Pt, Ni, Cu sensors : 2, 3, 4-wire -200 °C ... 850 °C (Range depends on sensor type, range can be set freely via software or in increments from -150°C to 850°C via DIP switches)	
≥ 20 K 0 Ω ... 4000 Ω (Minimum measuring span: 10% of the selected measuring range)	
U output 0 ... 5 V / 1 ... 5 V	I output 0 ... 20 mA / 4 ... 20 mA
0 ... 10 V / 10 ... 0 V approx. 12.3 V	20 ... 0 mA / 20 ... 4 mA 24.6 mA < 17.5 V
< 31.5 mA ≥ 10 kΩ < 10 mV _{rms}	≤ 600 Ω (at 20 mA) < 10 mV _{rms} (at 600 Ω)
9.6 V DC ... 30 V DC 32 mA (24 V DC) ≤ 850 mW (at I _{OUT} = 20 mA, 9.6 V DC, 600 Ω load)	
0.1 % * 350 K / set measuring range; 0.1 % > 350 K (Pt/Ni) 0.3 % * 200 K / set measuring range; 0.3 % > 200 K (Cu)	
0.01 %/K typ. 200 ms (2-wire) typ. 500 ms (3-wire) typ. 500 ms (4-wire) Reinforced insulation in accordance with IEC 61010-1 3 kV (50 Hz, 1 min.) -40 °C ... 70 °C PBT 6.2 / 110.5 / 120.5 mm 0.14 ... 2.5 mm ² / 0.14 ... 2.5 mm ² / 24 - 12 0.2 ... 1.5 mm ² / 0.2 ... 1.5 mm ² / 24 - 12 Class A product, see page 605	
CE-compliant Ex II 3 G Ex nA IIC T4 Gc X UL 508 Listed Class I, Div. 2, Groups A, B, C, D T6 Class I, Zone 2, Group IIC T6 C, EMC2	

Description
Temperature transducer for resistance thermometers
Standard configuration Push-in connection
Standard configuration Screw connection
Order configuration Push-in connection
Order configuration Screw connection

Programming adapter for configuring modules with S-PORT interface
Programming adapter for configuring modules with NFC interface
Bluetooth programming adapter , with USB and S-PORT interface

Ordering data		
Type	Order No.	Pcs./Pkt.
MINI MCR-2-RTD-UI-PT	2902052	1
MINI MCR-2-RTD-UI	2902049	1
MINI MCR-2-RTD-UI-PT-C	2902051	1
MINI MCR-2-RTD-UI-C	2902048	1

Accessories		
Type	Order No.	Pcs./Pkt.
IFS-USB-PROG-ADAPTER	2811271	1
NFC-USB-PROG-ADAPTER	2900013	1
IFS-BT-PROG-ADAPTER	2905872	1

Highly compact signal conditioners with plug-in connection technology – MINI Analog Pro

Order key for MINI MCR-2-RTD-UI(-PT)(-C) temperature transducers (standard configuration entered as example)

Order No.	Sensor type	Connection technology	Measuring range		Measuring unit	Output		
			Start	End		Output signal	Start	End
2902048	PT100	3	-50	150	C	I	4.0	20.0
2902048 ≙ MINI MCR-2-RTD-UI-C	PT100 ≙ Pt 100 IEC 751 PT200 ≙ Pt 200 IEC 751 PT500 ≙ Pt 500 IEC 751 PT1000 ≙ Pt 1000 IEC 751 PT100G ≙ Pt 100 GOST 6651-2009 (α = 0.00394) PT1000G ≙ Pt 1000 GOST 6651-2009 (α = 0.00394) PT100J ≙ Pt 100 JIS C1604/1997 PT1000J ≙ Pt 1000 JIS C1604/1997 NI100 ≙ Ni 100 DIN 43760 NI1000 ≙ Ni 1000 DIN 43760 CU50 ≙ Cu 50 GOST 6651-2009 (α = 0.00428) CU100 ≙ Cu 100 GOST 6651-2009 (α = 0.00428) CU53 ≙ Cu 53 GOST 6651-2009 (α = 0.00426)	2 ≙ 2-conductor 3 ≙ 3-conductor 4 ≙ 4-conductor	freely selectable between -200°C ... 850°C (measuring range limits depend on sensor type)	freely selectable between -200°C ... 850°C (measuring range limits depend on sensor type)	C ≙ °C F ≙ °F	I ≙ I U ≙ U	I: freely selectable between 0.0 ... 21 mA U: freely selectable between 0.0 ... 10.5 V	I: freely selectable between 0.0 ... 21 mA U: freely selectable between 0.0 ... 10.5 V
2902051 ≙ MINI MCR-2-RTD-UI-PT-C								

Minimum measuring span 20 K

Output signal span at least 0.5 V / 1 mA
Increment 0.1 V / 0.1 mA

Failure information

Behavior in the event of an error

Open circuit

Short circuit

Measured value overrange

Measured value underrange

...	NE43DO	0.0	0.0	0.0	0.0
FD ≙ Freely definable	0.0 ≙ 0 mA I: freely selectable between 0.0 ... 21.5 mA U: freely selectable between 0.0 ... 11 V (signal type corresponds to selected output signal)	0.0 ≙ 0 mA I: freely selectable between 0.0 ... 21.5 mA U: freely selectable between 0.0 ... 11 V (signal type corresponds to selected output signal)	0.0 ≙ 0 mA I: freely selectable between 0.0 ... 21.5 mA U: freely selectable between 0.0 ... 11 V (signal type corresponds to selected output signal)	0.0 ≙ 0 mA I: freely selectable between 0.0 ... 21.5 mA U: freely selectable between 0.0 ... 11 V (signal type corresponds to selected output signal)	0.0 ≙ 0 mA I: freely selectable between 0.0 ... 21.5 mA U: freely selectable between 0.0 ... 11 V (signal type corresponds to selected output signal)
Note: Failure information according to NE 43 can only be selected for 4 ... 20 mA output					
NE43UP ≙ NE 43 upscale NE43DO ≙ NE 43 downscale NE430 ≙ NE 43 0 mA NE43UD ≙ NE 43 upscale/downscale	21.5 mA 3.5 mA 0 mA 3.5 mA	21.5 mA 3.5 mA 0 mA 3.5 mA	21.5 mA 3.5 mA 0 mA 21.5 mA	21.5 mA 3.5 mA 0 mA 21.5 mA	21.5 mA 3.5 mA 0 mA 21.5 mA

Sensor types and measuring ranges for MINI MCR-2-RTD-UI(-PT)(-C) temperature transducers

Sensor type	Standard	Measuring range	Smallest measuring span	Adjustable using:
Pt 100	IEC 751 = GOST 6651-2009 (α = 0.00385)	-200°C to +850°C	20 K	DIP switches
Pt 200	IEC 751 = GOST 6651-2009 (α = 0.00385)	-200°C to +850°C	20 K	DIP switches
Pt 500	IEC 751 = GOST 6651-2009 (α = 0.00385)	-200°C to +850°C	20 K	Software or smartphone app
Pt 1000	IEC 751 = GOST 6651-2009 (α = 0.00385)	-200°C to +850°C	20 K	Software or smartphone app
Pt 100	GOST 6651-2009 (α = 0.00391)	-200°C to +850°C	20 K	Software or smartphone app
Pt 1000	GOST 6651-2009 (α = 0.00391)	-200°C to +850°C	20 K	Software or smartphone app
Pt 100	JIS C1604-1997	-200°C to +850°C	20 K	Software or smartphone app
Pt 1000	JIS C1604-1997	-200°C to +850°C	20 K	Software or smartphone app
Ni100	DIN 43760	-60°C to +250°C	20 K	Software or smartphone app
Ni 1000	DIN 43760	-60°C to +250°C	20 K	Software or smartphone app
Cu50	GOST 6651-2009 (α = 0.0428)	-180°C to +200°C	20 K	Software or smartphone app
Cu100	GOST 6651-2009 (α = 0.0428)	-180°C to +200°C	20 K	Software or smartphone app
Cu53	GOST 6651-2009 (α = 0.0426)	-50°C to +180°C	20 K	Software or smartphone app
Customer-specific characteristic curves		-200°C to +850°C	20 K	Software or smartphone app

Temperature
Temperature transducer for
thermocouples

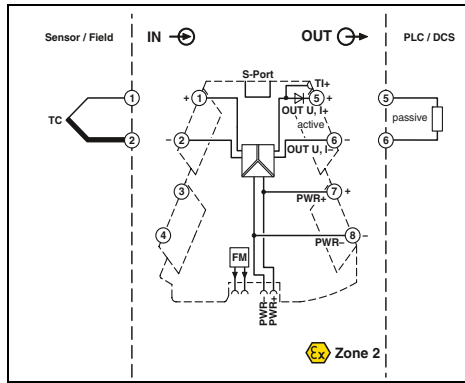
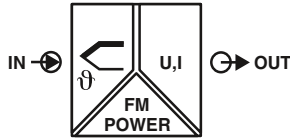

Ex n



Universal temperature transducer
for thermocouples



Housing width 6.2 mm

- Universally configurable, highly compact temperature transducer for electrical isolation, conversion, amplification, and filtering of thermocouple signals
- For thermocouples according to IEC 584 and GOST
- Internal cold junction compensation
- Plug-in connection system
- Safe 3-way isolation
- Standard signal combinations configurable via DIP switches
- Freely configurable with software or smartphone app
- Power supply and fault monitoring possible via DIN rail connector
- Status and error indicator LEDs

Notes:
The configuration software can be downloaded from the Internet: phoenixcontact.net/products .
Information on the programming adapters can be found on page 105
Information on MINI Analog Pro accessories can be found from page 101
To order a product with an order configuration, please enter the desired configuration by referring to the order key.

Input data	Input signal (can be configured using DIP switches) Temperature range
Measuring range span	
Output data	Output signal (configurable via DIP switch or freely via software)
Maximum output signal	No-load voltage Short-circuit current Load R_B Ripple
General data	Supply voltage range Current consumption Power consumption
Transmission error	
Cold junction errors	Temperature coefficient Step response (0–99%) Electrical isolation Test voltage, input/output/supply Ambient temperature (operation) Housing material Dimensions W/H/D Push-in connection solid/stranded/AWG Screw connection solid/stranded/AWG EMC note
Conformance/Approvals	Conformance ATEX UL, USA/Canada
DNV GL	

Technical data

B, C, E, J, K, N, R, S, T, L, U, A-1, A-2, A-3, M, L
-250 °C ... 2500 °C (Range depends on sensor type, range can be set freely via software or in increments from -150°C to 1350°C via DIP switches)

min. 50 K	I output
0 ... 5 V / 1 ... 5 V	0 ... 20 mA / 4 ... 20 mA
0 ... 10 V / 10 ... 0 V approx. 12.3 V	20 ... 0 mA / 20 ... 4 mA 24.6 mA < 17.5 V
< 31.5 mA ≥ 10 kΩ < 10 mV _{rms}	≤ 600 Ω (at 20 mA) < 10 mV _{rms} (at 600 Ω)

9.6 V DC ... 30 V DC
32.7 mA (24 V DC)
≤ 850 mW (at I_{OUT} = 20 mA, 9.6 V DC, 600 Ω load)

0.1% * 600 K / set measuring range; 0.1% > 600 K (C, E, J, K, N, T, L, U, M Gost, L Gost)
0.2% * 600 K / set measuring range; 0.2% > 600 K (B, R, S, A1, A2, A3)
0.2% * 600 K / set measuring range; 0.2% > 600 K (E, J, K, N, T, L, U, M Gost, L Gost); Highspeed Mode
0.4% * 600 K / set measuring range; 0.4% > 600 K (B, R, S, A1, A2, A3); Highspeed Mode
- (typ. 2 K (2 K + (0.2 K * ΔT)))
≤ 0.01 %/K
typ. 400 ms (Highspeed Mode: typ. 150 ms)
Reinforced insulation in accordance with IEC 61010-1
3 kV (50 Hz, 1 min.)
-40 °C ... 70 °C
PBT
6.2 / 110.5 / 120.5 mm
0.14 ... 2.5 mm² / 0.14 ... 2.5 mm² / 24 - 12
0.2 ... 1.5 mm² / 0.2 ... 1.5 mm² / 24 - 12
Class A product, see page 605

CE-compliant
Ex II 3 G Ex nA IIC T4 Gc X
UL 508 Listed
Class I, Div. 2, Groups A, B, C, D T6
Class I, Zone 2, Group IIC T6
C, EMC2

Ordering data

Type	Order No.	Pcs./Pkt.
MINI MCR-2-TC-UI-PT	2905249	1
MINI MCR-2-TC-UI	2902055	1
MINI MCR-2-TC-UI-PT-C	2905248	1
MINI MCR-2-TC-UI-C	2902053	1

Accessories

IFS-USB-PROG-ADAPTER	2811271	1
NFC-USB-PROG-ADAPTER	2900013	1
IFS-BT-PROG-ADAPTER	2905872	1

Description	
Temperature transducer for thermocouples	
Standard configuration	Push-in connection
Standard configuration	Screw connection
Order configuration	Push-in connection
Order configuration	Screw connection

Programming adapter for configuring modules with S-PORT interface	
Programming adapter for configuring modules with NFC interface	
Bluetooth programming adapter , with USB and S-PORT interface	

Highly compact signal conditioners with plug-in connection technology – MINI Analog Pro

Order key for MINI MCR-2-TC-UI(-PT)(-C) temperature transducers (standard configuration entered as an example)

Order No.	Sensor type	Cold junction error compensation	Measuring range		Measuring unit	Output	Output signal		...
			Start	End			Start	End	
2902053	J	1	-200	1200	C	I	4.0	20.0	...
2902053 ≙ MINI MCR-2-TC-UI-C	B ≙ B IEC 584-1 (Pt130Rh-Pt6Rh) E ≙ E IEC 584-1 (NiCr-CuNi) J ≙ J IEC 584-1 (Fe-CuNi) K ≙ K IEC 584-1 (NiCr-Ni) N ≙ N IEC 584-1 (NiCrSi-NiSi) R ≙ R IEC 584-1 (Pt13Rh-Pt) S ≙ S IEC 584-1 (Pt10Rh-Pt) T ≙ T IEC 584-1 (Cu-CuNi) L ≙ L DIN 43760 (Fe-CuNi) U ≙ U DIN 43760 (Cu-CuNi) A1G ≙ A-1 GOST 8.585-2001 A2G ≙ A-2 GOST 8.585-2001 A3G ≙ A-3 GOST 8.585-2001 MG ≙ M GOST 8.585-2001 LG ≙ L GOST 8.585-2001	0 ≙ OFF 1 ≙ ON	freely selectable between -250°C ... 2500°C (measuring range limits depend on sensor type)	freely selectable between -250°C ... 2500°C (measuring range limits depend on sensor type)	C ≙ °C F ≙ °F	I ≙ I U ≙ U	0.0 ≙ 0 mA I: freely selectable between 0.0 ... 21 mA U: freely selectable between 0.0 ... 10.5 V	20.0 ≙ 20 mA I: freely selectable between 0.0 ... 21 mA U: freely selectable between 0.0 ... 10.5 V	

Minimum measuring span 50 K

Output signal span at least 0.5 V / 1 mA
Increment 0.1 V / 0.1 mA

Failure information

Behavior in the event of an error

Open circuit

Measured value overrange

Measured value underrange

...	NE43DO	0.0	0.0	0.0
FD ≙ Freely definable	0.0 ≙ 0 mA I: freely selectable between 0.0 ... 21.5 mA U: freely selectable between 0.0 ... 11 V (signal type corresponds to selected output signal)	0.0 ≙ 0 mA I: freely selectable between 0.0 ... 21.5 mA U: freely selectable between 0.0 ... 11 V (signal type corresponds to selected output signal)	0.0 ≙ 0 mA I: freely selectable between 0.0 ... 21.5 mA U: freely selectable between 0.0 ... 11 V (signal type corresponds to selected output signal)	0.0 ≙ 0 mA I: freely selectable between 0.0 ... 21.5 mA U: freely selectable between 0.0 ... 11 V (signal type corresponds to selected output signal)
Note: Failure information according to NE 43 can only be selected for 4 ... 20 mA output				
NE43UP ≙ NE 43 upscale NE43DO ≙ NE 43 downscale NE430 ≙ NE 43 0 mA NE43UD ≙ NE 43 upscale/downscale	21.5 mA 3.5 mA 0 mA 3.5 mA	21.5 mA 3.5 mA 0 mA 21.5 mA	21.5 mA 3.5 mA 0 mA 21.5 mA	21.5 mA 3.5 mA 0 mA 21.5 mA

Sensor types and measuring ranges for MINI MCR-2-TC-UI(-PT)(-C) temperature transducers

Sensor type	Standard	Measuring range	Smallest measuring span	Adjustable using:
B	IEC 584-1	+500°C ... +1820°C	50 K	Software or smartphone app
E	IEC 584-1	-230°C ... +1000°C	50 K	Software or smartphone app
J	IEC 584-1	-210°C ... +1200°C	50 K	DIP switches
K	IEC 584-1	-250°C ... +1372°C	50 K	DIP switches
N	IEC 584-1	-200°C ... +1300°C	50 K	Software or smartphone app
R	IEC 584-1	-50°C ... +1768°C	50 K	Software or smartphone app
S	IEC 584-1	-50°C ... +1768°C	50 K	Software or smartphone app
T	IEC 584-1	-200°C ... +400°C	50 K	Software or smartphone app
L	DIN 43710	-200°C ... +900°C	50 K	Software or smartphone app
U	DIN 43710	-200°C ... +600°C	50 K	Software or smartphone app
A-1	GOST 8.585	0°C ... +2500°C	50 K	Software or smartphone app
A-2	GOST 8.585	0°C ... +1800°C	50 K	Software or smartphone app
A-3	GOST 8.585	0°C ... +1800°C	50 K	Software or smartphone app
M	GOST 8.585	-200°C ... +100°C	50 K	Software or smartphone app
L	GOST 8.585	-200°C ... +800°C	50 K	Software or smartphone app
Customer-specific characteristic curves		-250°C ... +2500°C	50 K	Software or smartphone app

Frequency
Universal frequency transducer

new

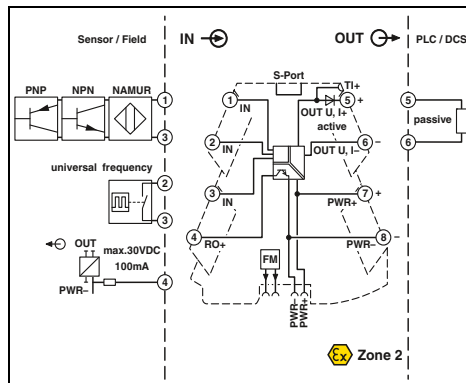
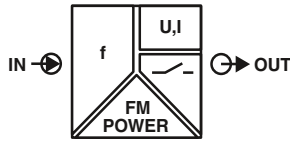

Configurable,
Universal frequency or PWM input

Housing width 6.2 mm

Technical data

- Universally configurable, highly compact 3-way isolated frequency transducer with transistor switching output
- Suitable for the connection of NAMUR proximity sensors (IEC 60947-5-6 and EN 50227) as well as for sensors with NPN and PNP outputs that generate a frequency signal
- For electrical isolation, conversion, amplification, and filtering of frequency and PWM signals
- Frequency signals in the range from 0.002 to 200 kHz and PWM signals up to 20 kHz
- Supports fault monitoring
- Plug-in connection system
- Safe 3-way isolation
- Standard behavior can be configured via DIP switches
- Freely configurable via software or smartphone app
- Power supply and fault monitoring possible via DIN rail connector
- Status and error indicator LEDs

Input data	Input sources PNP NPN NAMUR universal frequency PWR- max. 30VDC 100mA
Frequency measuring range	Maximum input signal PWM (range)
Output data	Output signal U output I output max. output signal Load R _B Ripple Switching output Relay output Max. switching voltage Maximum switching current Minimum switching current
General data	Supply voltage range Current consumption Power consumption Maximum transmission error Temperature coefficient Step response (0–99%) Electrical isolation Test voltage, input/output/supply Ambient temperature (operation) Dimensions W/H/D Push-in connection solid/stranded/AWG Screw connection solid/stranded/AWG EMC note Conformance/Approvals Conformance ATEX UL, USA/Canada GL

NAMUR initiators	NPN/PNP transistor outputs Floating contact (dry contact) Frequency generator Incremental encoder (speed only) HTL encoders
0 Hz ... 200 kHz	30 V (incl. DC voltage) 0.002 Hz ... 60 Hz (Duty cycle 2 ... 98 %) 60 Hz ... 300 Hz (Duty cycle 5 ... 95 %) 300 Hz ... 600 Hz (Duty cycle 10 ... 90 %) 600 Hz ... 1000 Hz (Duty cycle 20 ... 80 %)
U output	0 ... 10 V / 2 ... 10 V 0 ... 5 V / 1 ... 5 V approx. 12.3 V ≥ 10 kΩ < 20 mV _{pp} (at 600 Ω)
I output	0 ... 20 mA / 4 ... 20 mA 0 ... 10 mA / 2 ... 10 mA 24.6 mA ≤ 600 Ω (at 20 mA) < 20 mV _{pp} (at 600 Ω)
1 N/O contact	30 V DC 100 mA (30 V) 100 μA
9.6 V DC ... 30 V DC	32 mA (24 V DC) 63 mA (12 V DC) ≤ 1 W (at I _{OUT} = 20 mA, 9.6 V DC, 600 Ω load)
0.1 % (Frequency)	1 % (PWM signal) 0.01 %/K, typ. 0.01 %/K < 35 ms (f > 500 Hz) Reinforced insulation in accordance with IEC 61010-1 3 kV (50 Hz, 1 min.) -40 °C ... 70 °C 6.2 / 110.5 / 120.5 mm 0.14 ... 2.5 mm ² / 0.14 ... 2.5 mm ² / 24 - 12 0.2 ... 1.5 mm ² / 0.2 ... 1.5 mm ² / 24 - 12 Class A product, see page 605
CE-compliant	Ex II 3 G Ex nA IIC T4 Gc X UL 508 Listed Class I, Div. 2, Groups A, B, C, D T6 Class I, Zone 2, Group IIC T6 GL applied for

Notes:
The configuration software can be downloaded from the Internet: phoenixcontact.net/products.
Information on the programming adapters can be found on page 105

Description	MCR frequency transducer
	Push-in connection Screw connection

Programming adapter for configuring modules with S-PORT interface	
Programming adapter for configuring modules with NFC interface	
Bluetooth programming adapter , with USB and S-PORT interface	

Ordering data		
Type	Order No.	Pcs./ Pkt.
MINI MCR-2-F-UI-PT	2902058	1
MINI MCR-2-F-UI	2902056	1

Accessories		
IFS-USB-PROG-ADAPTER	2811271	1
NFC-USB-PROG-ADAPTER	2900013	1
IFS-BT-PROG-ADAPTER	2905872	1

Frequency
Analog frequency transducer

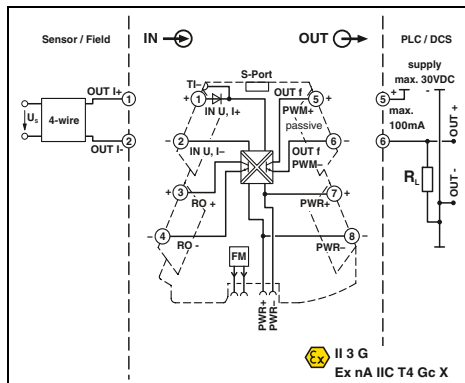
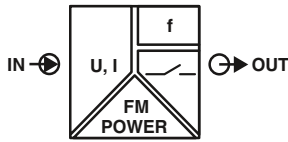

Ex n



Configurable,
frequency, PWM or switching output



Housing width 6.2 mm

- Universally configurable highly compact analog-to-frequency measuring transducer for electrical isolation, amplification, conversion and filtering of standard analog signals to frequencies or PWM signals
- Plug-in connection system
- Safe 3-way isolation
- Additional switching output
- Frequency output can be used as second switching output
- Standard signal combinations configurable via DIP switches
- Freely configurable with software or smartphone app
- Power supply and fault monitoring possible via DIN rail connector
- Status and error indicator LEDs

Notes:

The configuration software can be downloaded from the Internet: phoenixcontact.net/products .
Information on the programming adapters can be found on page 105
Information on MINI Analog Pro accessories can be found from page 101
To order a product with an order configuration, enter the required configuration by referring to the adjacent order key.

Input data	Input signal (configurable via DIP switch or freely via software)
Maximum input signal	12 V
Input resistance	> 120 kΩ
Output data	Output signal (configurable via DIP switch or freely via software)
Minimum load	100 mA
Load current maximum	24 mA
Maximum switching voltage	30 V
Overrange/underrange	Can be set (via software)
General data	Supply voltage range Nominal supply voltage Current consumption
Power consumption	≤ 350 mW (9.6 V DC)
Transmission error, maximum	≤ 0.1 % (> 7 kHz ≤ 0.2 %)
Temperature coefficient	< 0.01 %/K, typ. 0.01 %/K
Step response (0–99%)	120 ms (15 Hz sample rate)
Electrical isolation	Reinforced insulation in accordance with IEC 61010-1
Test voltage, input/output/supply	3 kV (50 Hz, 1 min.)
Degree of protection	IP20
Ambient temperature (operation)	-40 °C ... 70 °C
Dimensions W/H/D	6.2 / 110.5 / 120.5 mm
Push-in connection solid/stranded/AWG	0.14 ... 2.5 mm ² / 0.14 ... 2.5 mm ² / 24 - 12
Screw connection solid/stranded/AWG	0.2 ... 1.5 mm ² / 0.2 ... 1.5 mm ² / 24 - 12
EMC note	Class A product, see page 605
Conformance/Approvals	CE-compliant Ex II 3 G Ex nA IIC T4 Gc X UL 508 Listed Class I, Div. 2, Groups A, B, C, D T6 Class I, Zone 2, Group IIC T6 GL applied for
GL	

Technical data	
U input	I input
0 V ... 10 V	0 mA ... 20 mA
2 V ... 10 V	4 mA ... 20 mA
0 V ... 5 V	0 mA ... 10 mA
1 V ... 5 V	2 mA ... 10 mA
10 V ... 0 V	20 mA ... 0 mA
10 V ... 2 V	20 mA ... 4 mA
5 V ... 0 V	10 mA ... 0 mA
5 V ... 1 V	10 mA ... 2 mA
0 V ... 12 V	0 mA ... 24 mA
12 V	24 mA
> 120 kΩ	approx. 50 Ω (+ 0.7 V for test diode)
Frequency output	PWM output
0 Hz ... 10 kHz / 0 Hz ... 5 kHz	15.6 kHz (10 bit) / 1.9 kHz (10 bit)
0 Hz ... 2.5 kHz / 0 Hz ... 1 kHz	3.9 kHz (12 bit) / 488 Hz (12 bit)
0 Hz ... 500 Hz / 0 Hz ... 250 Hz	977 Hz (14 bit) / 122 Hz (14 bit)
0 Hz ... 100 Hz / 0 Hz ... 50 Hz	244 Hz (16 bit) / 31 Hz (16 bit)
4 mA ≤ (U _L / R _L) ≤ 100 mA	12 mA ≤ (U _L / R _L) ≤ 100 mA
100 mA	
30 V	
Can be set (via software)	
9.6 V DC ... 30 V DC	
24 V DC	
27 mA (12 V DC)	
13.5 mA (24 V DC)	
≤ 350 mW (9.6 V DC)	
≤ 0.1 % (> 7 kHz ≤ 0.2 %)	
< 0.01 %/K, typ. 0.01 %/K	
120 ms (15 Hz sample rate)	
Further values can be set via software	
Reinforced insulation in accordance with IEC 61010-1	
3 kV (50 Hz, 1 min.)	
IP20	
-40 °C ... 70 °C	
6.2 / 110.5 / 120.5 mm	
0.14 ... 2.5 mm ² / 0.14 ... 2.5 mm ² / 24 - 12	
0.2 ... 1.5 mm ² / 0.2 ... 1.5 mm ² / 24 - 12	
Class A product, see page 605	
CE-compliant	
Ex II 3 G Ex nA IIC T4 Gc X	
UL 508 Listed	
Class I, Div. 2, Groups A, B, C, D T6	
Class I, Zone 2, Group IIC T6	
GL applied for	

Description	
Analog frequency transducer with limit value function	
Standard configuration	Push-in connection
Standard configuration	Screw connection
Order configuration	Push-in connection
Order configuration	Screw connection

Programming adapter for configuring modules with S-PORT interface	
Programming adapter for configuring modules with NFC interface	
Bluetooth programming adapter , with USB and S-PORT interface	

Ordering data		
Type	Order No.	Pcs./ Pkt.
MINI MCR-2-UI-FRO-PT	2902032	1
MINI MCR-2-UI-FRO	2902031	1
MINI MCR-2-UI-FRO-PT-C	2906202	1
MINI MCR-2-UI-FRO-C	2906201	1

Accessories		
IFS-USB-PROG-ADAPTER	2811271	1
NFC-USB-PROG-ADAPTER	2900013	1
IFS-BT-PROG-ADAPTER	2905872	1

Highly compact signal conditioners with plug-in connection technology – MINI Analog Pro

Order key for MINI MCR-2-UI-FRO-(PT)(-C) analog frequency transducers (standard configuration entered as example)

Order No.	Input		Sample rate			Output		Output limitation	
	Input signal	Start	End	Start	End	Output signal	Carrier frequency	Start	End
2906201	I	0.0	20.0	15	I	0	0	1000	15
2906201 ≙ MINI MCR-2-UI-FRO-C	I ≙ I U ≙ U	0.0 ≙ 0 mA I: freely selectable between 0.0 ... 24 mA U: freely selectable between 0.0 ... 12 V	20.0 ≙ 20 mA I: freely selectable between 0.0 ... 24 mA U: freely selectable between 0.0 ... 12 V	15 Hz ≙ 15 Hz 60 Hz ≙ 60 Hz 240 Hz ≙ 240 Hz	f ≙ f	0 ≙ at frequency output 15.6 k ≙ 15.6 kHz 15.6 kHz (10 bits) 1.9 kHz (10 bits) 7.8 kHz (11 bits) 977 Hz (11 bits) 3.9 kHz (12 bits) 488 Hz (12 bits) 1.9 kHz (13 bits) 244 Hz (13 bits) 977 Hz (14 bits) 122 Hz (14 bits) 488 Hz (15 bits) 61 Hz (15 bits) 244 Hz (16 bits) 31 Hz (16 bits)	0 ≙ 0 Hz f: freely selectable between 0 ... 10 kHz D: freely selectable between 0.0 ... 100%	10000 ≙ 10 kHz f: freely selectable between 0 ... 10 kHz D: freely selectable between 0.0 ... 100%	0 ≙ off 1 ≙ on
2906202 ≙ MINI MCR-2-UI-FRO-PT-C					PWM ≙ PWM				

Measuring range span at least 0.5 V / 1 mA
Increment 0.1 V / 0.1 mA

Output signal span at least 10 Hz / 1%
Increment 1 Hz / 0.1%

Failure information

Behavior in the event of an error

Open circuit/short circuit

Measured value overrange

Measured value underrange

FD	0	0	0
FD ≙ Freely definable Failure information only adjustable for unlimited output	0 ≙ 0 Hz f: freely selectable between 0 ... 11 kHz D: freely selectable between 0.0 and 100% (free definition only for unlimited output) (signal type corresponds to selected output signal)	0 ≙ 0 Hz f: freely selectable between 0 ... 11 kHz D: freely selectable between 0.0 and 100% (free definition only for unlimited output) (signal type corresponds to selected output signal)	0 ≙ 0 Hz f: freely selectable between 0 ... 11 kHz D: freely selectable between 0.0 and 100% (free definition only for unlimited output) (signal type corresponds to selected output signal)

Potentiometer
Potiposition transducer

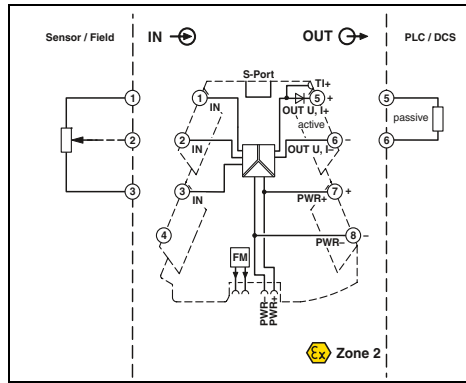
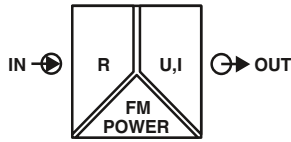

Potiposition transducer, Configurable

Housing width 6.2 mm

- Universally configurable, highly compact potiposition transducer for electrical isolation, conversion, amplification, and filtering of potentiometer signals
- For potentiometers from 100 Ω to 100 kΩ
- Automatic potentiometer detection without manual adjustment
- Plug-in connection system
- Safe 3-way isolation
- Standard signal combinations configurable via DIP switches
- Freely configurable with software or smartphone app
- Power supply and fault monitoring possible via DIN rail connector
- Status and error indicator LEDs

Notes:
The configuration software can be downloaded from the Internet: phoenixcontact.net/products .
Information on the programming adapters can be found on page 105
Information on MINI Analog Pro accessories can be found from page 101
To order a product with an order configuration, please enter the desired configuration by referring to the order key.

Input data	Potentiometer
Output data	Output signal (configurable via DIP switch or freely via software)
Maximum output signal	No-load voltage
	Short-circuit current
	Load R_B
	Ripple
	Behavior in the event of a sensor error
General data	Supply voltage range
	Nominal supply voltage
	Current consumption
	Power consumption
	Maximum transmission error
	Temperature coefficient
	Step response (0–99%)
	Electrical isolation
	Test voltage, input/output/supply
	Degree of protection
	Ambient temperature (operation)
	Mounting
	Housing material
	Dimensions W/H/D
	Push-in connection solid/stranded/AWG
	Screw connection solid/stranded/AWG
	EMC note
Conformance/Approvals	Conformance
	ATEX
	UL, USA/Canada
DNV GL	

Technical data

100 Ω ... 100 kΩ	U output	I output
1 ... 5 V / 10 ... 0 V	0 ... 5 V / 0 ... 10 V	0 ... 20 mA / 4 ... 20 mA
approx. 12.3 V	20 ... 0 mA / 20 ... 4 mA	24.6 mA
< 31.5 mA	< 17.5 V	< 17.5 V
≥ 10 kΩ	< 20 mV _{PP} (at 10 kΩ)	≤ 600 Ω (at 20 mA)
< 20 mV _{PP} (at 10 kΩ)	configurable	< 20 mV _{PP}
9.6 V DC ... 30 V DC	24 V DC	33 mA (24 V DC)
≤ 850 mW (at I _{OUT} = 20 mA, 9.6 V DC, 600 Ω load)	< 0.1 % (R < 240 Ω = < 0.2 %)	0.01 %/K, typ. 0.01 %/K
< 60 ms	Reinforced insulation in accordance with IEC 61010-1	3 kV (50 Hz, 1 min.)
IP20	-40 °C ... 70 °C	any
PBT	6.2 / 110.5 / 120.5 mm	0.14 ... 2.5 mm ² / 0.14 ... 2.5 mm ² / 24 - 12
Class A product, see page 605	CE-compliant	Ex II 3 G Ex nA IIC T4 Gc X
	UL 508 Listed	Class I, Div. 2, Groups A, B, C, D T5
	Class I, Zone 2, Group IIC T5	C, EMC2

Ordering data

Description	Order configuration
Potiposition transducer	
Standard configuration	Push-in connection
Standard configuration	Screw connection
Order configuration	Push-in connection
Order configuration	Screw connection

Type	Order No.	Pcs./Pkt.
MINI MCR-2-POT-UI-PT	2902017	1
MINI MCR-2-POT-UI	2902016	1
MINI MCR-2-POT-UI-PT-C	2905006	1
MINI MCR-2-POT-UI-C	2905005	1

Accessories

Programming adapter for configuring modules with S-PORT interface	IFS-USB-PROG-ADAPTER	2811271	1
Programming adapter for configuring modules with NFC interface	NFC-USB-PROG-ADAPTER	2900013	1
Bluetooth programming adapter , with USB and S-PORT interface	IFS-BT-PROG-ADAPTER	2905872	1

IFS-USB-PROG-ADAPTER	2811271	1
NFC-USB-PROG-ADAPTER	2900013	1
IFS-BT-PROG-ADAPTER	2905872	1

Highly compact signal conditioners with plug-in connection technology – MINI Analog Pro

Order key for MINI MCR-2-POT-UI(-PT)(-C) potipotentiometer transducers (standard configuration entered as an example)

Order No.	Automatic potentiometer detection	Output			Filter	Open circuit detection	...
		Output signal	Start	End			
2905005	AUTO	I	4.0	20.0	1	ON	
2905005 ≙ MINI MCR-2- POT-UI-C	AUTO ≙ ON OFF ≙ OFF	I ≙ I U ≙ U	0.0 ≙ 0 mA I: freely selectable between 0.0 ... 21 mA U: freely selectable between 0.0 ... 10.5 V	20.0 ≙ 20 mA I: freely selectable between 0.0 ... 21 mA U: freely selectable between 0.0 ... 10.5 V	1 2 3 4 5 6 7 8 9 10	ON ≙ ON OFF ≙ OFF	
2905006 ≙ MINI MCR-2- POT-UI-PT-C							

Output signal span at least 0.5 V / 1 mA
Increment 0.1 V / 0.1 mA

Failure information

Behavior in the event of an error

Open circuit slider

Input open (no potentiometer connected)

Measured value overrange

Measured value underrange

...	NE43DO	0.0	0.0	0.0	0.0
FD ≙ Freely definable	0.0 ≙ 0 mA I: freely selectable between 0.0 ... 21.5 mA U: freely selectable between 0.0 ... 11 V (only if open circuit detection is on) (signal type corresponds to selected output signal)	0.0 ≙ 0 mA I: freely selectable between 0.0 ... 21.5 mA U: freely selectable between 0.0 ... 11 V (signal type corresponds to selected output signal)	0.0 ≙ 0 mA I: freely selectable between 0.0 ... 21.5 mA U: freely selectable between 0.0 ... 11 V (signal type corresponds to selected output signal)	0.0 ≙ 0 mA I: freely selectable between 0.0 ... 21.5 mA U: freely selectable between 0.0 ... 11 V (signal type corresponds to selected output signal)	0.0 ≙ 0 mA I: freely selectable between 0.0 ... 21.5 mA U: freely selectable between 0.0 ... 11 V (signal type corresponds to selected output signal)
Note: Failure information according to NE 43 can only be selected for 4 ... 20 mA output					
NE43UP ≙ NE 43 upscale NE43DO ≙ NE 43 downscale NE430 ≙ NE 43 0 mA NE43UD ≙ NE 43 upscale/downscale	21.5 mA 3.5 mA 0 mA 3.5 mA	21.5 mA 3.5 mA 0 mA 3.5 mA	21.5 mA 3.5 mA 0 mA 3.5 mA	21.5 mA 3.5 mA 0 mA 21.5 mA	21.5 mA 3.5 mA 0 mA 21.5 mA

Digital IN
Signal conditioner

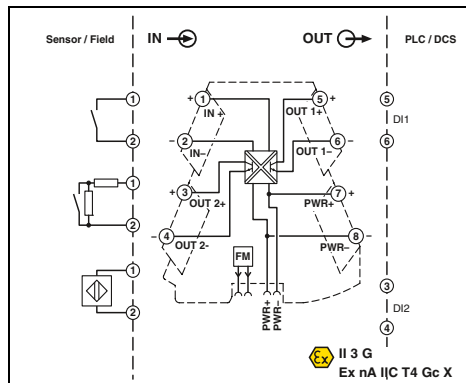
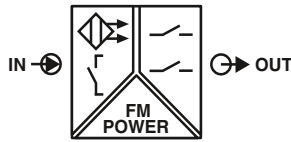

Ex n



Configurable,
for NAMUR sensors and
floating contacts



Housing width 6.2 mm

- Highly compact signal conditioner for electrical isolation, amplification, and duplication of proximity sensor signals
- For proximity sensors in accordance with IEC 60947-5-6 and EN 50227
- Floating contacts and contacts with resistance circuit can be connected
- Plug-in connection system
- Input and output signals can be configured via DIP switches
- Transistor switching contacts on the output
- Second output can be used as a duplicator or error signaling output
- Safe 3-way isolation
- Switchover between operating current and quiescent current (inverted switching behavior)
- Power supply and fault monitoring possible via DIN rail connector
- Status LEDs

Notes:
Information on MINI Analog Pro accessories can be found from page 101

Input data	Input signal
Control circuit	No-load voltage Switching points (in acc. with IEC 60947-5-6)
Line fault detection	
Switching output	Transistor output Max. switching voltage Max. switching current Switching frequency
General data	Supply voltage range Nominal supply voltage Current consumption
Power consumption	Electrical isolation Test voltage, input/output/supply Degree of protection Ambient temperature (operation) Mounting Housing material Dimensions W/H/D Push-in connection solid/stranded/AWG Screw connection solid/stranded/AWG EMC note
Conformance/Approvals	Conformance ATEX UL, USA/Canada
GL	

Technical data

NAMUR proximity sensors (EN 60947-5-6) open circuit switch contacts Switch contacts with resistance circuit
8.2 V DC ±10 % < 1.2 mA (blocking) > 2.1 mA (conductive) > 6 mA (in the event of a short-circuit) < 0.35 mA (With wire break)
2 N/O contacts 30 V DC 50 mA 5 kHz
9.6 V DC ... 30 V DC 24 V DC 18 mA (24 V DC) 35 mA (12 V DC) 450 mW (9.6 V DC) Reinforced insulation in accordance with IEC 61010-1 3 kV (50 Hz, 1 min.) IP20 -40 °C ... 70 °C any PBT 6.2 / 110.5 / 120.5 mm 0.14 ... 2.5 mm ² / 0.14 ... 2.5 mm ² / 24 - 12 0.2 ... 1.5 mm ² / 0.2 ... 1.5 mm ² / 24 - 12 Class A product, see page 605
CE-compliant Ex nA IIC T4 Gc X UL 508 Listed Class I, Div. 2, Groups A, B, C, D T6 Class I, Zone 2, Group IIC T6 GL applied for

Description	
NAMUR signal conditioner	Push-in connection Screw connection

Ordering data

Type	Order No.	Pcs./ Pkt.
MINI MCR-2-NAM-2RO-PT	2902005	1
MINI MCR-2-NAM-2RO	2902004	1

Limit values

Threshold value switch

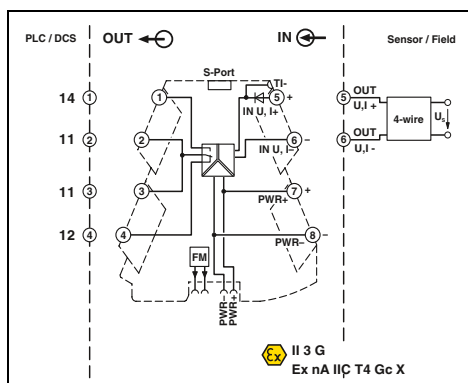
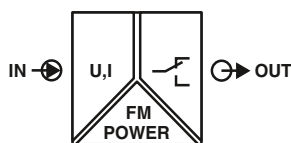

Ex n



Configurable, with relay PDT output



Ex:

Housing width 6.2 mm

Technical data

Input data	U input	I input
Input signal (configurable using the DIP switch)	0 ... 10 V / 0 ... 12 V	0 ... 20 mA / 0 ... 24 mA
Maximum input signal	12 V	24 mA
Input resistance	> 120 kΩ	approx. 50 Ω (+ 0.7 V for test diode)
Specification of the switching point	Can be set via software or in steps via DIP switches	
Switching output	1 PDT	
Relay output	AgSnO ₂ , hard gold-plated	
Contact material	250 V AC	
Max. switching voltage	6 A	
Limiting continuous current	can be set freely via software	
Hysteresis (configurable using the DIP switch)	0 s ... 10 s (can be set freely via software)	
Setting range of the response delay (configurable using the DIP switch)		
General data	9.6 V DC ... 30 V DC	
Supply voltage range	24 V DC	
Nominal supply voltage	40 mA (12 V DC)	
Current consumption	20 mA (24 V DC)	
Power consumption	≤ 0.5 W	
Maximum transmission error	0.1 % (of final value)	
Temperature coefficient	0.01 %/K	
Step response (0–99%)	typ. 140 ms (Can be set via software)	
Electrical isolation	Reinforced insulation in accordance with IEC 61010-1	
Test voltage, input/output/supply	3 kV (50 Hz, 1 min.)	
Degree of protection	IP20	
Ambient temperature (operation)	-40 °C ... 70 °C	
Mounting	any	
Housing material	PBT	
Dimensions W/H/D	6.2 / 110.5 / 120.5 mm	
Push-in connection solid/stranded/AWG	0.14 ... 2.5 mm ² / 0.14 ... 2.5 mm ² / 24 - 12	
Screw connection solid/stranded/AWG	0.2 ... 1.5 mm ² / 0.2 ... 1.5 mm ² / 24 - 12	
EMC note	Class A product, see page 605	
Conformance/Approvals	CE-compliant	
Conformance	II 3 G Ex nA nC IIC T4 Gc X	
ATEX	UL 508 Listed	
UL, USA/Canada	Class I, Div. 2, Groups A, B, C, D T4A	
	Class I, Zone 2, Group IIC T4A	
	GL applied for	

- Universally configurable highly compact threshold value switch for switching analog limit values
- Plug-in connection system
- Safe 3-way isolation
- Standard switching behavior can be configured via DIP switches
- Freely configurable with software or smartphone app
- PDT relay at output
- Limiting continuous current up to 6 A
- Power supply and fault monitoring possible via DIN rail connector
- Status and error indicator LEDs

Notes:

The configuration software can be downloaded from the Internet: phoenixcontact.net/products.

Information on the programming adapters can be found on page 105

Information on MINI Analog Pro accessories can be found from page 101

Description	
Threshold value switch with relay PDT output, standard configuration	
	Push-in connection
	Screw connection

Programming adapter for configuring modules with S-PORT interface
Programming adapter for configuring modules with NFC interface
Bluetooth programming adapter , with USB and S-PORT interface

Ordering data

Type	Order No.	Pcs./Pkt.
MINI MCR-2-UI-REL-PT	2902035	1
MINI MCR-2-UI-REL	2902033	1

Accessories

IFS-USB-PROG-ADAPTER	2811271	1
NFC-USB-PROG-ADAPTER	2900013	1
IFS-BT-PROG-ADAPTER	2905872	1

Limit values
Temperature

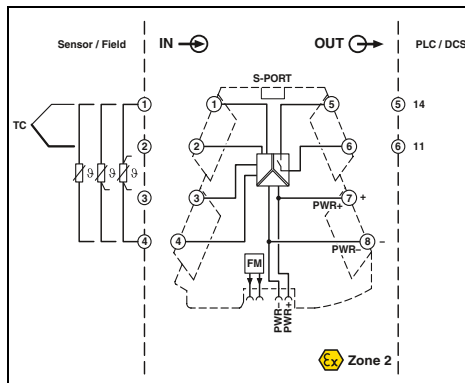
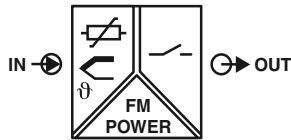

Ex n

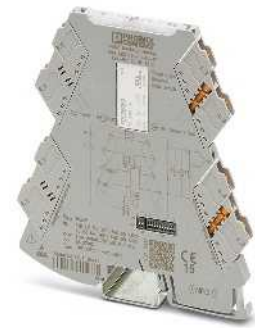

Configurable, temperature transducer with N/O relay output



Housing width 6.2 mm

Technical data

- Universally configurable, highly compact temperature limit value switch for switching analog limit values from resistance thermometers and remote resistance-type sensor signals
- For 2, 3 or 4-wire RTD sensors according to IEC 751, JIS, GOST
- For thermocouples according to IEC 584 and GOST
- Internal cold junction compensation
- Plug-in connection system
- Safe 3-way isolation
- Standard behavior can be configured via DIP switches
- Freely configurable via software or smartphone app
- N/O relay output (N/C function can be set via software)
- Limiting continuous current up to 6 A
- Power supply and fault monitoring possible via DIN rail connector
- Status and error indicator LEDs

Input data

Input signal (can be configured using DIP switches)
Temperature range
Measuring range span
Linear resistance measuring range

Switching output

Relay output
Contact material
Max. switching voltage
Maximum switching current
Minimum switching current
Limiting continuous current
Hysteresis
Setting range of the response delay

General data

Supply voltage range
Current consumption

Switching point accuracy
Power consumption
Temperature coefficient
Step response (0–99%)

Electrical isolation

Test voltage, input/output/supply
Ambient temperature (operation)
Housing material
Dimensions W/H/D
Push-in connection solid/stranded/AWG
Screw connection solid/stranded/AWG
EMC note

Conformance/Approvals

Conformance
ATEX
UL, USA/Canada

Pt, Ni, Cu sensors : 2, 3, 4-wire
-250 °C ... 2500 °C
min. 20 K
0 Ω ... 4000 Ω

1 N/O contact
AgSnO₂, hard gold-plated
250 V AC
6 A (for 250 V AC)
100 mA (12 V DC)
6 A
can be set freely via software
0 s ... 10 s (can be set freely via software)

9.6 V DC ... 30 V DC
44 mA (12 V DC)
22 mA (24 V DC)
< 0.1 %
570 mW
0.01 %/K
typ. 300 ms
typ. 570 ms
typ. 380 ms
typ. 300 ms
typ. 570 ms
Reinforced insulation in accordance with IEC 61010-1
3 kV (50 Hz, 1 min.)
-40 °C ... 70 °C
PBT
6.2 / 110.5 / 120.5 mm
0.14 ... 2.5 mm² / 0.14 ... 2.5 mm² / 24 - 12
0.2 ... 1.5 mm² / 0.2 ... 1.5 mm² / 24 - 12
Class A product, see page 605

CE-compliant
Ex II 3 G Ex nA nC IIC T4 Gc X
UL 508 Listed
Class I, Div. 2, Groups A, B, C, D T4A
Class I, Zone 2, Group IIC T4A
GL applied for

Notes:
The configuration software can be downloaded from the Internet: phoenixcontact.net/products.
Information on the programming adapters can be found on page 105

GL

Description
Temperature limit value switch
Push-in connection Screw connection

Programming adapter for configuring modules with S-PORT interface
Programming adapter for configuring modules with NFC interface
Bluetooth programming adapter , with USB and S-PORT interface

Ordering data

Type	Order No.	Pcs./Pkt.
MINI MCR-2-T-REL-PT	2905633	1
MINI MCR-2-T-REL	2905632	1

Accessories

IFS-USB-PROG-ADAPTER	2811271	1
NFC-USB-PROG-ADAPTER	2900013	1
IFS-BT-PROG-ADAPTER	2905872	1

Limit values
Temperature

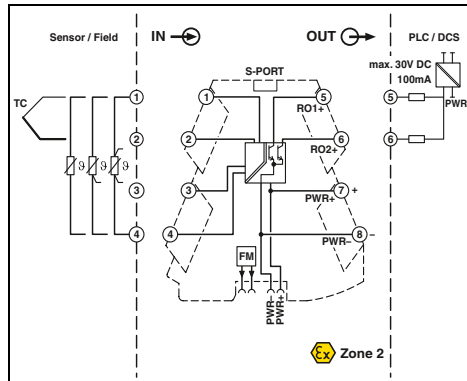
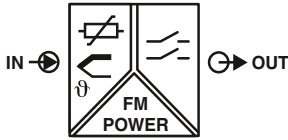

Configurable, temperature transducer with transistor output



Housing width 6.2 mm

- Universally configurable, highly compact temperature limit value switch for switching analog limit values from resistance thermometers and remote resistance-type sensor signals
- For 2, 3 or 4-wire RTD sensors according to IEC 751, JIS, GOST
- For thermocouples according to IEC 584 and GOST
- Internal cold junction compensation
- Plug-in connection system
- Safe 3-way isolation
- Standard behavior can be configured via DIP switches
- Freely configurable via software or smartphone app
- 2 transistor switching contacts on the output
- Maximum switching current 30 V / 100 mA
- Power supply and fault monitoring possible via DIN rail connector
- Status and error indicator LEDs

Input data

Input signal (can be configured using DIP switches)
Temperature range
Measuring range span
Linear resistance measuring range

Switching output

Transistor output
Max. switching voltage
Maximum switching current

General data

Supply voltage range
Current consumption

Switching point accuracy
Power consumption
Temperature coefficient
Step response (0-99%)

Electrical isolation

Test voltage, input/output/supply
Ambient temperature (operation)
Housing material
Dimensions W/H/D
Push-in connection solid/stranded/AWG
Screw connection solid/stranded/AWG
EMC note

Conformance/Approvals

Conformance
ATEX
UL, USA/Canada

GL

Technical data

Pt, Ni, Cu sensors : 2, 3, 4-wire
-250 °C ... 2500 °C
min. 20 K
0 Ω ... 4000 Ω

2 N/O contacts
30 V DC
100 mA (30 V (≤ 50 °C))

9.6 V DC ... 30 V DC
20 mA (12 V DC)
10 mA (24 V DC)

< 0.1 %
350 mW
0.01 %/K
typ. 300 ms
typ. 570 ms
typ. 380 ms
typ. 300 ms
typ. 570 ms

Reinforced insulation in accordance with IEC 61010-1
3 kV (50 Hz, 1 min.)
-40 °C ... 70 °C

PBT
6.2 / 110.5 / 120.5 mm
0.14 ... 2.5 mm² / 0.14 ... 2.5 mm² / 24 - 12
0.2 ... 1.5 mm² / 0.2 ... 1.5 mm² / 24 - 12
Class A product, see page 605

CE-compliant
Ex II 3 G Ex nA IIC T4 Gc X
UL 508 Listed
Class I, Div. 2, Groups A, B, C, D T6
Class I, Zone 2, Group IIC T6
GL applied for

Notes:
The configuration software can be downloaded from the Internet: phoenixcontact.net/products.
Information on the programming adapters can be found on page 105

Description
Temperature limit value switch
Push-in connection
Screw connection

Programming adapter for configuring modules with S-PORT interface
Programming adapter for configuring modules with NFC interface
Bluetooth programming adapter , with USB and S-PORT interface

Ordering data

Type	Order No.	Pcs./Pkt.
MINI MCR-2-T-2RO-PT	2906877	1
MINI MCR-2-T-2RO	2906876	1

Accessories

IFS-USB-PROG-ADAPTER	2811271	1
NFC-USB-PROG-ADAPTER	2900013	1
IFS-BT-PROG-ADAPTER	2905872	1



Safely isolated from field to network. MINI Analog Pro signal conditioners with bus and network connections combine the benefits of safe electrical isolation with those of digital communication. With an overall width of less than 50 mm, you can transmit, free of interference, up to eight field signals to industrial networks, without the need for signal-specific input cards.

Further advantages:

- Gateways for different protocols: Modbus RTU, Modbus TCP, and PROFIBUS DP
- Interference-free signal transmission from the field level to the CPU, thanks to safe electrical isolation
- Fast, fault-free wiring, by bundling the signals in one network cable

Highly compact signal conditioners with plug-in connection technology – MINI Analog Pro



No need for input cards

- Cost and space savings, as signal-specific input cards are no longer needed



Modular and space-saving

- Space-saving network integration of freely combinable signal conditioners by means of plug-in gateways



Flexible configuration

- Quick parameterization via rotary coding switch, software, web server or app



Smart configuration and monitoring

- Carry out on-site configuration and read current values directly off a smartphone with the MINI Analog Pro app



Easy startup and servicing

- Measure current signals during operation, without disconnecting current loops

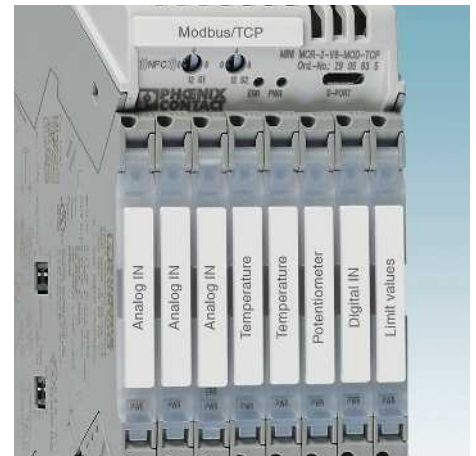

Easy maintenance

- Large-surface marking areas for standard marking material as well as permanently visible status and error LEDs on each module

MINI Analog Pro gateways

- Easy integration of up to eight field signals in the bus systems
- Any combination of signal conditioners is possible (standard signal, temperature, etc.)
- Easy attachment to the output side of MINI Analog Pro modules
- Huge savings in terms of input cards and bus couplers
- Safe channel-to-channel electrical isolation right through to the CPU
- Versions with PROFIBUS DP, Modbus/RTU or Modbus/TCP are available
- Can be configured via software or smartphone app

Notes:
 The configuration software can be downloaded from the Internet: phoenixcontact.net/products.
 Information on the programming adapters can be found on page 105

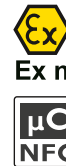
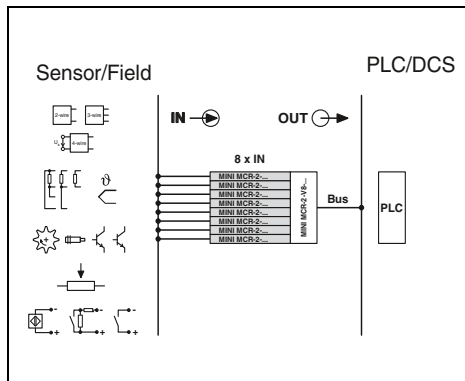

new

Gateways for bus and network connection

Ex:
 Housing width 51.1 mm

Input data	
Number of inputs	8
Configurable/programmable	Yes
Current input signal	4 mA ... 20 mA
Maximum input current	24 mA
Input resistance of current input	50 Ω
Maximum input voltage	5 V
Output data	
Number of outputs	1
Data update rate	15 ms
General data	
Nominal supply voltage range	12 V ... 24 V
Supply voltage range	9.6 V ... 30 V
Power consumption	< 1000 mW
Maximum transmission error	0.1 %
Temperature coefficient	0.01 %
Test voltage, input/output/supply	0.5 kV
Ambient temperature (operation)	-40 °C ... 65 °C
Housing material	PBT 7% GF V0
Dimensions W/H/D	51.1 / 104.1 / 56.8 mm
EMC note	Class A product, see page 605
Conformance/Approvals	
Conformance	CE-compliant
UL, USA/Canada	UL 61010 Listed Class I, Div. 2, Groups A, B, C, D T5 Class I, Zone 2, Group IIC T5

Technical data

Description
Gateways for bus and network connection
Modbus/RTU
Modbus/TCP
PROFIBUS DP

Ordering data

Type	Order No.	Pcs./Pkt.
MINI MCR-2-V8-MOD-RTU	2905634	1
MINI MCR-2-V8-MOD-TCP	2905635	1
MINI MCR-2-V8-PB-DP	2905636	1

Programming adapter for configuring modules with S-PORT interface
Programming adapter for configuring modules with NFC interface
Bluetooth programming adapter , with USB and S-PORT interface

Accessories

Type	Order No.	Pcs./Pkt.
IFS-USB-PROG-ADAPTER	2811271	1
NFC-USB-PROG-ADAPTER	2900013	1
IFS-BT-PROG-ADAPTER	2905872	1

MINI Analog Pro system adapter

new

- Time-saving wiring solution thanks to unique plug-in concept
- System cabling on PLC side
- Plug-and-Play
- For up to eight channels
- Reduced wiring effort and errors
- Easy attachment to the output side of MINI Analog Pro modules
- Especially easy to maintain, thanks to interruption-free current measurement function

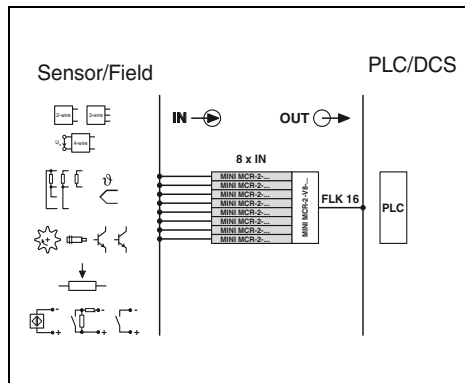

System cabling adapter



Housing width 51.1 mm

Technical data

Input data	
Number of inputs	8
Configurable/programmable	no
Maximum input current	4 A (500 mA per ch.)
Maximum input voltage	30 V
Output data	
Number of outputs	8
Connection method	IDC/FLK pin strip
Configurable/programmable	no
General data	
Test voltage input/output	0.5 kV
Rated insulation voltage	50 V _{rms}
Degree of protection	IP20
Overvoltage category / Degree of pollution	II / 2
Ambient temperature (operation)	-40 °C ... 70 °C
Humidity	5 % ... 95 %
Maximum altitude for use above sea level	4000 m
Housing material	PBT 7% GF V0
Dimensions W/H/D	51.1 / 104.1 / 56.8 mm
Conformance/Approvals	
Conformance	CE-compliant
ATEX	Ex II 3 G Ex nA IIC Gc U
UL, USA/Canada	UL 61010 Listed Class I, Div. 2, Groups A, B, C, D T5 Class I, Zone 2, Group IIC T5
GL	GL applied for

Ordering data

Description	Type	Order No.	Pcs./Pkt.
System cabling adapter for MINI Analog Pro modules	MINI MCR-2-V8-FLK 16	2901993	1

Termination Carrier for MINI Analog Pro signal conditioner



Select standard DIN rail device

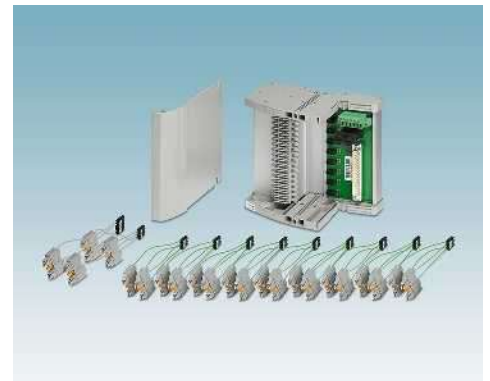

Select module carrier

TC... Termination Carriers are compact solutions for conveniently and smoothly connecting standard DIN rail signal conditioners from the MINI Analog Pro series to input and output cards of automation systems using system cabling.

The most compact signal conditioners combined with the most compact and flexible module carriers on the market enable you to achieve a hitherto unparalleled packing density in your control cabinet together with professional system cabling.

Compact

- The compact design associated with MINI Analog saves up to 65% of space in the control cabinet

Robust and reliable

- Stable, vibration-resistant aluminum carrier device profile
- PCB is completely decoupled from signal conditioners
- PCB without active electronics
- Redundant supply via separate DIN rail module
- Horizontal or vertical DIN rail mounting

Flexible

- Profile sections without pitch markings
- Quick and safe module connection with plug-in cable sets
- Horizontal or vertical DIN rail mounting
- Can be flexibly adapted to suit any controller or higher-level control system
- Solutions tailored to your requirements on request
- Available pre-assembled with modules and wired, or for self-assembly



Select controller-specific front adapter and system cable



Solutions are also available for MACX Analog, MACX Analog Ex, and Safety

Termination Carrier for MINI Analog Pro signal conditioner

The **TC-D37SUB-ADIO16-MP-P-UNI** universal Termination Carrier is a compact solution which connects signal conditioners from the MINI Analog Pro series to analog or binary input and output cards of automation systems.

The **TC-D37SUB-AIO16-MP-PS-UNI** Termination Carrier design, when combined with the MACX MCR-S-MUX HART multiplexer, also enables communication between HART-capable field devices and a management system.

- Connection of up to 16 single-channel signal conditioners
- Universal 1:1 signal routing to a 37-pos. D-SUB connector
- For system cables with D-SUB socket and open ends for universal connection
- Redundant supply and monitoring via separate MINI MCR-2-PTB-PT power terminal and MINI MCR-2-FM-RC-PT fault signaling module

Notes:
 Contact us: together, we can develop optimum solutions for your automation system with the Termination Carrier for MINI Analog Pro.
 TC-D37SUB-ADIO16-MP-P-UNI (Order No. 2906639) is not a class A product.



Ex: Housing width 136 mm

General data	
Connection to the control system level	Connection to the control system level
Number of positions	37
Maximum operating voltage	< 30 V DC (Per signal/channel)
Maximum permissible current	23 mA (Signal/channel)
Rated insulation voltage	50 V
Degree of pollution	2
Overvoltage category	II
Rated surge voltage	0.5 kV
Air clearances and creepage distances	DIN EN 50178 (Basic insulation)
Ambient temperature range	-20 °C ... 60 °C (Please observe module specifications)
Shock	15g, according to IEC 60068-2-27
Vibration (operation)	2g, according to IEC 60068-2-6
Dimensions W/H/D	136 / 170 / 160 mm
Power supply via power module	
Input voltage range	19.2 V DC ... 30 V DC
Redundant supply	yes, decoupled from diodes
Polarization and surge protection	Yes
Fuse	2x 2.5 A on PCB, slow-blow (replaceable)
Status indication	2 x red LED (error) 2x green LEDs (PWR1 and PWR2) 1 N/C contact (alarm = open)
Switching output	

Technical data	
D-SUB pin strip	37
Maximum operating voltage	< 30 V DC (Per signal/channel)
Maximum permissible current	23 mA (Signal/channel)
Rated insulation voltage	50 V
Degree of pollution	2
Overvoltage category	II
Rated surge voltage	0.5 kV
Air clearances and creepage distances	DIN EN 50178 (Basic insulation)
Ambient temperature range	-20 °C ... 60 °C (Please observe module specifications)
Shock	15g, according to IEC 60068-2-27
Vibration (operation)	2g, according to IEC 60068-2-6
Dimensions W/H/D	136 / 170 / 160 mm
Power supply via power module	
Input voltage range	19.2 V DC ... 30 V DC
Redundant supply	yes, decoupled from diodes
Polarization and surge protection	Yes
Fuse	2x 2.5 A on PCB, slow-blow (replaceable)
Status indication	2 x red LED (error) 2x green LEDs (PWR1 and PWR2) 1 N/C contact (alarm = open)
Switching output	

Description	
Module carrier for 16 MINI Analog channels, power and feed-through module	
- With connection for MACX MCR-S-MUX HART multiplexer	

Ordering data		
Type	Order No.	Pcs./Pkt.
TC-D37SUB-ADIO16-MP-P-UNI	2906639	1
TC-D37SUB-AIO16-MP-PS-UNI	2906640	1

MINI Analog Pro power terminal	
MINI Analog Pro fault signaling module	MINI MCR-2-PTB-PT 2902067
HART multiplexer, 32-channel, including two 14-wire flat-ribbon cable	MINI MCR-2-FM-RC-PT 2904508 MACX MCR-S-MUX 2865599

Accessories		
MINI MCR-2-PTB-PT	2902067	1
MINI MCR-2-FM-RC-PT	2904508	1
MACX MCR-S-MUX	2865599	1

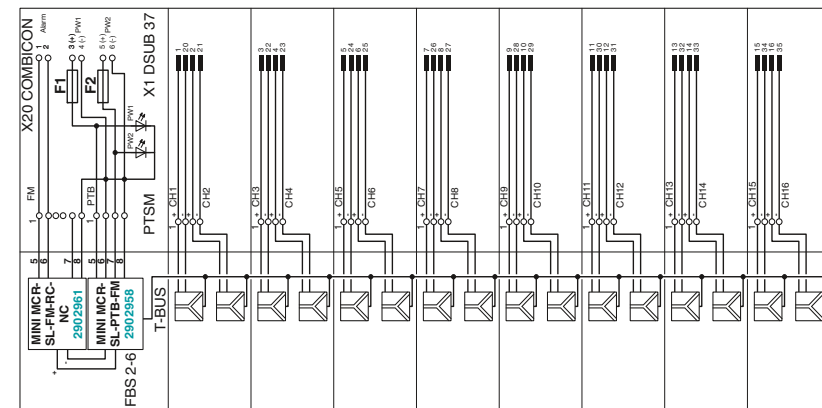

TC-D37SUB-ADIO16-M-P-UNI and TC-D37SUB-AIO16-M-PS-UNI connection scheme

Accessories

Constant voltage/
constant current source

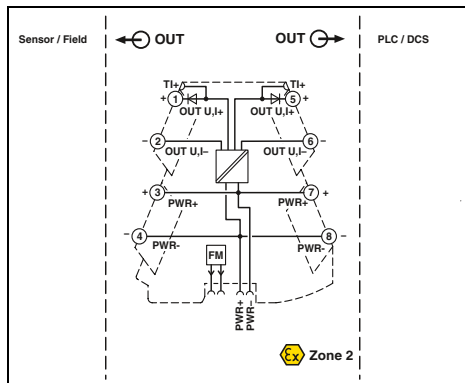
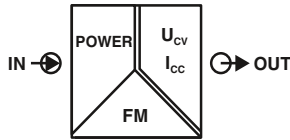

Ex n



Output signals, configurable



Housing width 6.2 mm

- Constant voltage/constant current source for potentiometers, measuring bridges, encoders, etc.
- Plug-in connection system
- Highly precise
- Output signals can be configured via DIP switches
- Input signal corresponds to power supply
- Input signal and therefore energy supply and fault monitoring via the DIN rail connector
- For voltages up to 10 V and currents up to 20 mA
- Status LED

Input data	
Input signal	9.6 ... 30 V
Output data	
Output signal (can be configured using DIP switches)	U output 10 V DC 20 mA 8.75 V DC 17.5 mA 7.5 V DC 15 mA 6.25 V DC 12.5 mA 5 V DC 10 mA 3.75 V DC 7.5 mA 2.5 V DC 5 mA 1.25 V DC 2.5 mA
Short-circuit current	> 32 mA
Ripple	< 20 mV _{pp} (at 600 Ω)
General data	
Supply voltage range	9.6 V DC ... 30 V DC
Power consumption	< 1.1 W (9.6 V DC)
Maximum transmission error	≤ 0.1 % (of final value)
Temperature coefficient	< 0.01 %/K
Electrical isolation	Reinforced insulation in accordance with IEC 61010-1
Test voltage, input/output/supply	3 kV (50 Hz, 1 min.)
Degree of protection	IP20
Ambient temperature (operation)	-40 °C ... 70 °C
Housing material	PBT
Dimensions W/H/D	6.2 / 110.5 / 120.5 mm
Push-in connection solid/stranded/AWG	0.14 ... 2.5 mm ² / 0.14 ... 2.5 mm ² / 24 - 12
Screw connection solid/stranded/AWG	0.2 ... 1.5 mm ² / 0.2 ... 1.5 mm ² / 24 - 12
EMC note	Class A product, see page 605
Conformance/Approvals	
Conformance	CE-compliant
ATEX	Ex II 3 G Ex nA IIC T4 Gc X
UL, USA/Canada	UL 508 Listed Class I, Div. 2, Groups A, B, C, D T6 Class I, Zone 2, Group IIC T6

Technical data

Technical data	
U output	10 V DC 20 mA 8.75 V DC 17.5 mA 7.5 V DC 15 mA 6.25 V DC 12.5 mA 5 V DC 10 mA 3.75 V DC 7.5 mA 2.5 V DC 5 mA 1.25 V DC 2.5 mA
Short-circuit current	> 32 mA
Ripple	< 20 mV _{pp} (at 600 Ω)
General data	
Supply voltage range	9.6 V DC ... 30 V DC
Power consumption	< 1.1 W (9.6 V DC)
Maximum transmission error	≤ 0.1 % (of final value)
Temperature coefficient	< 0.01 %/K
Electrical isolation	Reinforced insulation in accordance with IEC 61010-1
Test voltage, input/output/supply	3 kV (50 Hz, 1 min.)
Degree of protection	IP20
Ambient temperature (operation)	-40 °C ... 70 °C
Housing material	PBT
Dimensions W/H/D	6.2 / 110.5 / 120.5 mm
Push-in connection solid/stranded/AWG	0.14 ... 2.5 mm ² / 0.14 ... 2.5 mm ² / 24 - 12
Screw connection solid/stranded/AWG	0.2 ... 1.5 mm ² / 0.2 ... 1.5 mm ² / 24 - 12
EMC note	Class A product, see page 605
Conformance/Approvals	
Conformance	CE-compliant
ATEX	Ex II 3 G Ex nA IIC T4 Gc X
UL, USA/Canada	UL 508 Listed Class I, Div. 2, Groups A, B, C, D T6 Class I, Zone 2, Group IIC T6

Description	
Constant voltage/constant current source	
	Push-in connection
	Screw connection

Ordering data		
Type	Order No.	Pcs./Pkt.
MINI MCR-2-CVCS-PT	2902065	1
MINI MCR-2-CVCS	2902064	1

Setpoint potentiometer , to set setpoints individually	
Resistance value 4.7 kΩ	
Resistance value 10 kΩ	

Accessories		
EMG 30-SP- 4K7LIN	2940252	10
EMG 30-SP-10K LIN	2942124	10

Accessories

Connector set

- FASTCON Pro connector set
- Consisting of four connectors, one each for every position on the module
- Suitable for all MINI Analog Pro modules
- Four-way coding prevents incorrect insertion into the device
- Screw or Push-in connection technology



with Push-in connection



with screw connection

Technical data
Connection data solid/stranded/AWG
Description
FASTCON Pro connector set - with Push-in connection - with screw connection

Technical data		
0.14 ... 2.5 mm ² / 0.14 ... 2.5 mm ² / 24 - 12		
Ordering data		
Type	Order No.	Pcs./ Pkt.
FASTCON PRO-SET-PT	2906228	1

Technical data		
0.2 ... 1.5 mm ² / 0.2 ... 1.5 mm ² / 24 - 12		
Ordering data		
Type	Order No.	Pcs./ Pkt.
FASTCON PRO-SET	2906227	1

Accessories

Setpoint potentiometers

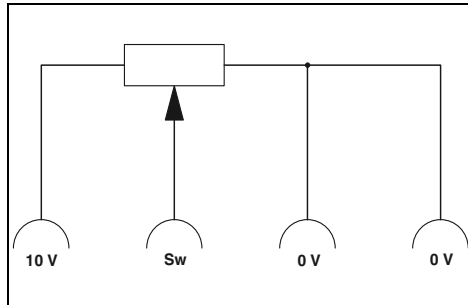
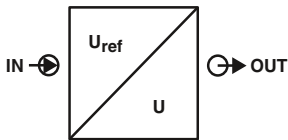

- For direct setpoint definition in combination with a constant voltage source

Input data
Resistance value
Linearity
Load capacity
General data
Ambient temperature (operation)
Mounting
Housing material
Dimensions W/H/D
Screw connection solid/stranded/AWG

Technical data	
EMG 30-SP- 4K7LIN	EMG 30-SP-10K LIN
4.7 kΩ ±20 %	10 kΩ ±20 %
5 % (of final value)	5 % (of final value)
0.5 W	0.5 W
0 °C ... 40 °C	
any	
Polycarbonate fiber reinforced PC-F	
30 / 75 / 68 mm	
0.2 ... 4 mm ² / 0.2 ... 2.5 mm ² / 24 - 14	

Description
Setpoint potentiometer , to set setpoints individually
Resistance value 4.7 kΩ
Resistance value 10 kΩ

Ordering data		
Type	Order No.	Pcs./ Pkt.
EMG 30-SP- 4K7LIN	2940252	10
EMG 30-SP-10K LIN	2942124	10

Accessories

ME 6,2 TBUS... DIN rail connector

- For bridging the supply voltage
- Reduced wiring effort
- Module replacement without interrupting the supply to the remaining modules (hot swappable)
- One DIN rail connector for two MINI Analog Pro modules
- Only distinguished by color coding



For bridging the supply voltage



For bridging the supply voltage

Description
DIN rail connector (TBUS) , for bridging the supply voltage, can be snapped onto 35 mm DIN rails according to EN 60715, with UL approval
Color: green Color: gray

Ordering data		
Type	Order No.	Pcs./ Pkt.
ME 6,2 TBUS-2 1,5/5-ST-3,81 GN	2869728	10

Ordering data		
Type	Order No.	Pcs./ Pkt.
ME 6,2 TBUS-2 1,5/5-ST-3,81 GY	2695439	10

Accessories

Power terminals

- Power terminal for supplying the supply voltage to the DIN rail connector
- Plug-in connection system
- Increased output current of 3.2 A
- For up to 115 MINI Analog Pro modules
- Monitoring of supplies in combination with the fault monitoring module
- Flexible redundant supply from one or both module sides
- Status and error indicator LEDs

Notes:
Pay attention to the supply instructions for the MINI and MACX modules.

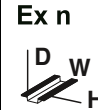
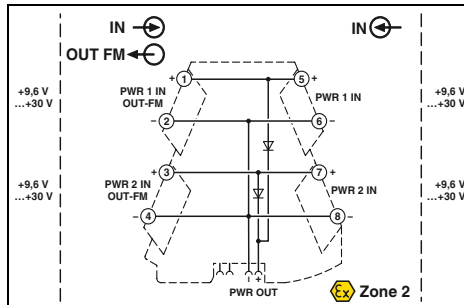

Redundant supply for existing 24 V

Input data/output data
Input voltage range
Output voltage
Output current
General data
Ambient temperature (operation)
Housing material
EMC note
Conformance/Approvals
Conformance
ATEX
UL, USA/Canada
DNV GL

Technical data	
9.9 V DC ... 30 V DC	9.6 V DC ... 29.7 V DC
≤ 3.2 A	
-40 °C ... 70 °C	
PBT	
Class A product, see page 605	
CE-compliant	
Ex II 3 G Ex nA IIC T4 Gc X	
UL 508 Listed	
Class I, Div. 2, Groups A, B, C, D T6	
Class I, Zone 2, Group IIC T6	
C, EMC2	

Description
MINI Analog Pro power terminal
Push-in connection
Screw connection

Ordering data		
Type	Order No.	Pcs./ Pkt.
MINI MCR-2-PTB-PT	2902067	1
MINI MCR-2-PTB	2902066	1

Accessories

ME 17,5 TBUS-... DIN rail connector

- For bridging the supply voltage when using a MINI POWER system power supply

Notes:

If the system power supply is used, two ME 17,5 TBUS DIN rail connectors are required. This allows you to establish the connection to the ME 6,2 TBUS DIN rail connector of the MINI Analog system and provide an effective power supply.



For system power supply

Description	Ordering data		
	Type	Order No.	Pcs./Pkt.
DIN rail connector , for bridging the supply voltage, can be snapped onto 35 mm DIN rails according to EN 60715, with UL approval, two pieces are required per system power supply	ME 17,5 TBUS 1,5/ 5-ST-3,81 GN	2709561	10

Accessories

System power supply

- For supplying the supply voltage via the DIN rail connector where AC voltages are available
- Nominal input voltage range 100 ... 240 V AC
- 24 V DC output voltage
- For up to 60 MINI Analog modules
- For up to 1.5 A, secondary
- Status and error signaling via diagnostic LEDs



For applications with local voltages of over 100 V

Description	Ordering data		
	Type	Order No.	Pcs./Pkt.
System power supply , primary-switched, with Zone 2 approval. Further information can be found in Catalog 4, Surge protection and power supplies.	MINI-PS-100-240AC/24DC/1.5/EX	2866653	1
System power supply , primary-switched (not for Zone 2) You can find further information in Catalog 4, Surge protection and power supplies.	MINI-SYS-PS-100-240AC/24DC/1.5	2866983	1

Accessories

Feed-through terminal blocks

- Feed-through terminal block for 1:1 forwarding of signals that are already electrically isolated in the MINI Analog Pro group
- Plug-in connection system

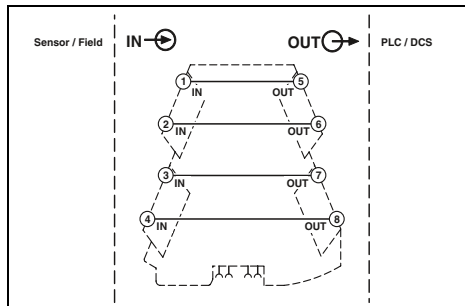

Ex n



For signals already electrically isolated

General data	
Degree of protection	IP20
Ambient temperature (operation)	-40 °C ... 70 °C
Mounting	any
Housing material	PBT
Dimensions W/H/D	6.2 / 110.5 / 120.5 mm
Screw connection solid/stranded/AWG	0.2 ... 1.5 mm ² / 0.2 ... 1.5 mm ² / 24 - 12
Conformance/Approvals	
Conformance	CE-compliant
ATEX	Ex II 3 G Ex nA IIC T4 Gc X
UL, USA/Canada	UL 508 Listed Class I, Div. 2, Groups A, B, C, D T6 Class I, Zone 2, Group IIC T6 C, EMC2
DNV GL	

Technical data

Degree of protection	IP20
Ambient temperature (operation)	-40 °C ... 70 °C
Mounting	any
Housing material	PBT
Dimensions W/H/D	6.2 / 110.5 / 120.5 mm
Screw connection solid/stranded/AWG	0.2 ... 1.5 mm ² / 0.2 ... 1.5 mm ² / 24 - 12
Conformance/Approvals	
Conformance	CE-compliant
ATEX	Ex II 3 G Ex nA IIC T4 Gc X
UL, USA/Canada	UL 508 Listed Class I, Div. 2, Groups A, B, C, D T6 Class I, Zone 2, Group IIC T6 C, EMC2

Description	
MINI Analog Pro feed-through terminal block	
	Screw connection

Ordering data

Type	Order No.	Pcs./Pkt.
MINI MCR-2-TB	2902068	1

Accessories

Fault signaling modules

- Fault monitoring module for evaluating and reporting group errors from the fault monitoring system
- Monitoring of up to 115 connected MINI Analog Pro modules
- Plug-in connection system
- Monitoring of supply voltages of MINI MCR-2-PTB(-PT) power terminals
- Drawing off the supply is possible
- Fault signaling via an N/C contact
- Status and error indicator LEDs
- CE-compliant

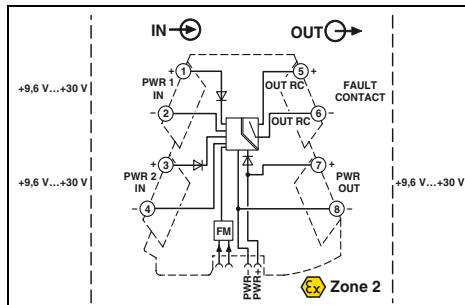

Ex n



For group error message and supply monitoring

Input data/output data	
Input signal	9.9 V DC ... 30 V DC
Output signal	9.6 V DC ... 29.7 V DC
Switching output	
Max. switching voltage	30 V DC
Maximum switching current	50 mA
General data	
Test voltage input/output	1.5 kV AC (50 Hz, 1 min.)
EMC note	Class A product, see page 605
Conformance/Approvals	
ATEX	Ex II 3 G Ex nA IIC T4 Gc X
UL, USA/Canada	UL 508 Listed Class I, Div. 2, Groups A, B, C, D T6 Class I, Zone 2, Group IIC T6 C, EMC2
DNV GL	

Technical data

Input signal	9.9 V DC ... 30 V DC
Output signal	9.6 V DC ... 29.7 V DC
Switching output	
Max. switching voltage	30 V DC
Maximum switching current	50 mA
General data	
Test voltage input/output	1.5 kV AC (50 Hz, 1 min.)
EMC note	Class A product, see page 605
Conformance/Approvals	
ATEX	Ex II 3 G Ex nA IIC T4 Gc X
UL, USA/Canada	UL 508 Listed Class I, Div. 2, Groups A, B, C, D T6 Class I, Zone 2, Group IIC T6 C, EMC2

Description	
MINI Analog Pro fault signaling module	
	Push-in connection
	Screw connection

Ordering data

Type	Order No.	Pcs./Pkt.
MINI MCR-2-FM-RC-PT	2904508	1
MINI MCR-2-FM-RC	2904504	1

Accessories

Programming adapters

IFS-USB-PROG-ADAPTER and NFC-USB-PROG-ADAPTER programming adapters for configuring Phoenix Contact INTERFACE modules with S-PORT or NFC interface.

The adapters are used with the FDT/DTM or the ANALOG-CONF software. For programming the MACX Analog, MINI Analog Pro, and MINI Analog.



General data	
EMC note	
Description	
Programming adapter for configuring modules with S-PORT interface	
Programming adapter for configuring modules with NFC interface	
Bluetooth programming adapter , with USB and S-PORT interface	

Technical data		
Class A product, see page 605		
Ordering data		
Type	Order No.	Pcs./Pkt.
IFS-USB-PROG-ADAPTER	2811271	1
NFC-USB-PROG-ADAPTER	2900013	1
IFS-BT-PROG-ADAPTER	2905872	1

Accessories

Marking label for transparent cover

- Snap-in labels and adhesive labels with large area for marking
- For snapping into or sticking onto MINI Analog Pro covers, without overlapping the status and error LEDs
- The sheets can be marked quickly and easily using the BLUEMARK CLED and the THERMOMARK CARD...
- They can also be custom printed according to customer requirements



Unmarked or marked according to customer specifications

Ordering data		
Type	Order No.	Pcs./Pkt.
UCT-EM (30X5)	0801505	10
UCT-EM (30X5) CUS	0801589	1
UC-EMLP (15X5)	0819301	10
UC-EMLP (15X5) CUS	0824550	1

Ordering data		
Type	Order No.	Pcs./Pkt.
SK 5,0 WH:REEL	0805221	1

Description	Color
UniCard , for marking the CLIPFIX 35-5 end bracket, 24-section, 8 individual labels per strip, lettering field size: 30 x 5 mm	white
Lettering field size: 30 x 5 mm	white
10-section, lettering field size: 15 x 5 mm	white
10-section, lettering field size: 15 x 5 mm	white
Continuous labels , can be marked with thermal transfer printer, can be separated with a cutter, pitch as desired, strip length up to 1000 mm	white
1 roll = 90 m continuous, height: 5.0 mm, 10 strips	white



Machine building/process industry
 EN ISO 13849-1
 EN 62061
 IEC 61508
 EN 60511



PL
EN ISO 13849

Signal conditioner with PL functional safety
 MACX Safety



PL
EN ISO 13849

Ex i signal conditioner with PL functional safety
 MACX Safety Ex

Process industry
 IEC 61508
 EN 60511



SIL
IEC 61508

Signal conditioner with SIL functional safety
 MACX Analog



SIL
IEC 61508

Ex i signal conditioner with SIL functional safety
 MACX Analog Ex

No intrinsic safety

Intrinsic safety
 ATEX/IECEx
 EN 60079-11



Reliable and safe

Highest safety for your machines and systems.

Phoenix Contact meets the requirements of functional safety according to IEC 61508 in a standardized development process. We take measures for fault avoidance and fault control into consideration, from the development and production of a device up to device operation.

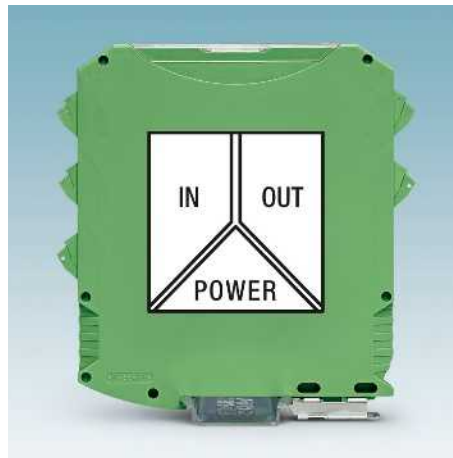

Precise, interference-free signal transmission and long service life

- Patented transmission concept with safe electrical isolation
- Low power consumption and self-heating



Easy configuration and monitoring

- Either via FDT/DTM or alternatively with user-friendly stand-alone software – with integrated monitoring function
- Or without software via DIP switches on the housing front or with the operator interface and display unit



Easy installation, power bridging, and diagnostics

- Flexible supply voltage bridging and the option of redundant, diode-decoupled supply and error indication.
- Plug-in, coded connection terminal blocks with test sockets, optionally with screw connection or with fast Push-in connection technology



Fast and error-free signal connection

- Compact Termination Carriers connect MACX Analog devices to the automation system – Plug and Play



Ex i signal conditioner and PL d-certified signal conditioner

- Single and two-channel signal isolators for intrinsically safe circuits up to Zone 0 and Zone 20
- Integrate analog signals into safety applications according to the Machinery Directive with ease

Facts about explosion protection

The chemical and petrochemical industries involve industrial processes which produce explosive atmospheres. They are caused, for example, by gases, fumes or vapors. Explosive atmospheres are also likely to occur in mills, silos, and sugar and fodder factories due to the dust present there.

Therefore, electrical devices in potentially explosive areas are subject to special directives.

Devices and protective systems in potentially explosive areas

European Parliament directive 94/9/EC of March 23, 1994 (ATEX manufacturer directive) is of particular importance within CENELEC (European Community and Western European EFTA states). It is designed to facilitate the harmonization of legal provisions in the member states of the European Union for devices and protective systems in terms of ensuring correct use in potentially explosive areas. Directive 94/9/EC must be applied to all explosion-protected devices and protective systems placed on the market in the European Union.

The scope of this directive also includes safety, monitoring, and control devices which are used outside of potentially explosive areas, but which are necessary for, or contribute towards, the safe operation of devices and protective systems with respect to explosion hazards.

The term **device** includes machines, equipment, stationary or mobile devices, control components, and system accessories. The directive also covers alarm and protection systems which are meant to be used, either individually or in combination, for the generation, transmission, storage, measurement, control, and conversion of energy as well as for processing materials and which have the potential to ignite and cause an explosion.

Protective systems are devices designed to stop an incipient explosion immediately and/or restrict the area affected by the explosion, and which are placed on the market separately as autonomous systems.



Components are defined as those parts that are necessary for ensuring the safe operation of devices and protective systems, but do not perform an autonomous function in themselves.

European directives are implemented in ordinances or laws at a national level.

Systems in potentially explosive areas

Directive 1999/92/EC (ATEX Operator Directive) was passed in Europe to regulate the operation of systems in potentially explosive areas.

Terminology associated with the Ex area	
Explosive atmosphere	A mixture of combustible gases, steam, vapors or dust and air in atmospheric conditions that allow the entire mixture to combust once ignited.
Potentially explosive area	An area where the atmosphere has the potential to explode due to local or operational conditions ("Ex area").
Electrical equipment	The entire set of components, electric circuits or parts of electric circuits that are usually located within a single housing.
Intrinsically safe electrical equipment	An electrical device in which all circuits are intrinsically safe. Note: These devices may be used directly in the Ex area.
Associated equipment	Electrical devices that contain both intrinsically safe and non-intrinsically-safe circuits and that are designed in such a way that the non-intrinsically-safe circuits cannot influence the intrinsically safe ones. Note: Associated electrical equipment must not be used directly in potentially explosive areas without additional protection defined by a further type of protection.

Classification into groups

The general stipulations of EN 60079-0 divide electrical devices for potentially explosive areas into three groups.

Group I:

Electrical devices for firedamp areas (mines) which are susceptible to pit gases (methane) and/or combustible dusts (coal dust).

Group II:

Electrical devices for operation in areas where explosive gas atmospheres are likely to occur, excluding mines susceptible to firedamp.

These include: devices for the chemical, petrochemical, and pharmaceutical industries as well as for wastewater treatment.

Electrical devices are further divided into subcategories according to the properties of the explosive atmosphere.

In the case of the intrinsic safety type of protection, classification is based on the minimum ignition energy of the gas or vapor.

Designation	Typical gas	Ignition energy/I intrinsic safety
II A	Propane	> 180
II B	Ethylene	60 ... 180
II C	Hydrogen	< 60

Group III:

Electrical devices for operation in areas where explosive dust atmospheres are likely to occur, excluding mines susceptible to firedamp.

These include: devices for areas associated with the food industry (mills, silos), for example.

Electrical devices are further divided into subcategories according to the properties of the explosive atmosphere.

Designation	Dusts
III A	Combustible flyings
III B	Non-conductive dust
III C	Conductive dust

Classification into temperature classes

Simply dividing the various gases into explosion or gas groups according to their minimum ignition energy is not sufficient to describe the gases adequately with regard to their explosive properties.

A gas may explode either when the ignition energy is exceeded or where there is an excessively high temperature caused by a hot surface. This ignition temperature is, however, not usually linked to the ignition energy, i.e., a gas with a low ignition energy does not necessarily explode at a low temperature. Consequently, devices that are used directly in potentially explosive atmospheres are divided into temperature classes. Temperature classes define the maximum surface temperature even in the event of errors. Parallel to this, the gases are classified according to their different ignition temperatures.

Temperature class	Maximum permissible surface temperature of the equipment °C	Ignition temperatures of combustible substances °C
T 1	450	> 450
T 2	300	> 300 ≤ 450
T 3	200	> 200 ≤ 300
T 4	135	> 135 ≤ 200
T 5	100	> 100 ≤ 135
T 6	85	> 85 ≤ 100

The following table provides an overview of the ignition energies and ignition temperatures for certain gases:

Substance	T _{ign}	Temperature class	E _{min}	Group
Ethoxyethane	170	T 4	190	II B
Ethylene	425	T 2	82	II B
Ammonia	630	T 1	14000	II A
Butane	365	T 2	250	II A
Methane	595	T 1	280	I
Propane	470	T 1	250	II A
Carbon disulfide	95	T 6	9	II C
Hydrogen	560	T 1	16	II C

Zone classification

Potentially explosive areas are divided into zones according to the probability of their occurrence. The EN 60079-10-1 standard defines the zones containing **explosive atmospheres** as follows:

Zone 0:

Area in which an explosive atmosphere is present for continuous or long periods.

These conditions are usually present inside containers, pipelines, apparatus, and tanks.

Zone 1:

Area in which an explosive atmosphere is to be expected only occasionally during normal operation.

This includes the immediate area surrounding Zone 0, as well as areas close to filling and emptying equipment.

Zone 2:

Area in which an explosive atmosphere is not expected during normal operation; however, if it does occur, then it does so only rarely and for a short period.

Zone 2 includes areas that are used exclusively for storage, areas around pipe connections that can be disconnected, and generally the immediate area surrounding Zone 1.

Areas that are potentially explosive as a result of **combustible dusts** are divided into the following zones according to EN 60079-10-2 (formerly: EN 61241-10):

Zone 20:

Area in which an explosive atmosphere is present for continuous, frequent or long periods in the form of an airborne cloud of combustible dust.

Zone 21:

Area in which an explosive atmosphere in the form of an airborne cloud of combustible dust is to be expected only occasionally during normal operation.

Zone 22:

Area in which an explosive atmosphere in the form of an airborne cloud of combustible dust is not expected during normal operation. However, if it does occur, then it does so only for a short period.

Categories

The ATEX directive assigns devices for use in potentially explosive areas to categories. In IEC 60079-0, "Equipment Protection Level (EPL)" is the term used instead of "category".

In the same way that there are different zones, there are also different device categories. These consist of categories M1 and M2 for Group I and categories 1, 2, and 3 for Group II. The categories for **equipment group II** are described in more detail below:

Category 1:

Devices constructed to guarantee a very high degree of safety.

Devices in this category must guarantee the required degree of safety even in the unlikely event of a device failure and therefore be provided with measures to protect against explosion, so that:

- In the event of one integrated protection measure failing, a second, independent protection measure is able to guarantee the necessary safety, or
- In the event of two independent errors, the necessary safety is guaranteed.

Category 2:

Devices constructed to guarantee a very high degree of safety.

The explosion protection measures associated with this category guarantee the required degree of safety, even in the case of frequent device failures or common error states.

Category 3:





Devices constructed to guarantee a standard degree of safety.

Devices in this category guarantee an adequate degree of safety in normal operation.

The table below shows which categories are assigned to which zones:

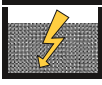
Category	For zone	Also possible
1	0 20	1 and 2 21 and 22
2	1 21	2 22
3	2 22	

Types of protection

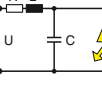
Protection principle	Type of protection	Area of application (selection)	Standard
 <p>Isolation</p>	Oil immersion	o Transformers, relays, startup controls, switching devices	EN 60079-6
	Sand filling	q Transformers, relays, capacitors	EN 60079-5
	Molded encapsulation	m* Coils of relays and motors, electronics, solenoid valves, connection systems	EN 60079-18
 <p>Exclusion</p>	Pressurized enclosure	p Control cabinets, motors, measuring and analysis devices, computers	EN 60079-2
 <p>Special mechanical design</p>	Flameproof enclosure	d Motors, switching devices, power electronics	EN 60079-1
 <p>Clearance from electrically conductive parts</p>	Increased safety	e Terminal blocks, housing, lights, motors	EN 60079-7
 <p>Energy limitation</p>	Intrinsic safety	i* Electronics, MCR	EN 60079-11
	Intrinsically safe systems	Electronic systems	EN 60079-25
	Intrinsically safe fieldbus systems	Fieldbus systems	EN 60079-27
<p>Improved industrial quality</p> <p>nA: non-sparking nC: sparking equipment nR: restricted breathing housing nL: energy-limited nP: simplified pressurized enclosures</p>	Protection type "n"	n** Motors, housing, lights, electronics	EN 60079-15
<p>* ia, ma: application in Zone 0, 1, 2 / ib, mb: application in Zone 1, 2 / ic, mc: application in Zone 2 only ** Application in Zone 2 only</p>			

Marking according to ATEX directive

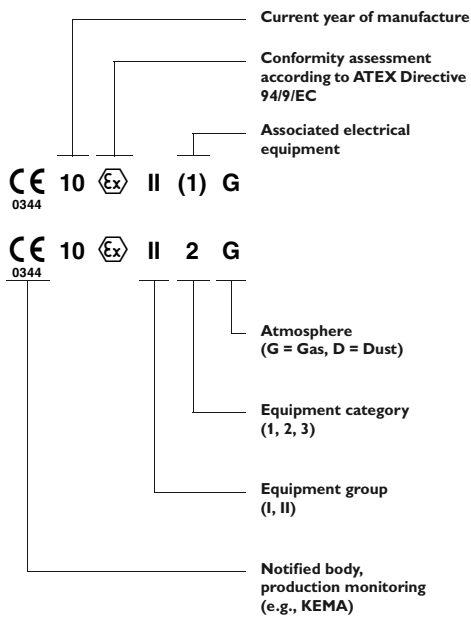

CE mark does not apply to components.

Marking according to EN 60079-0

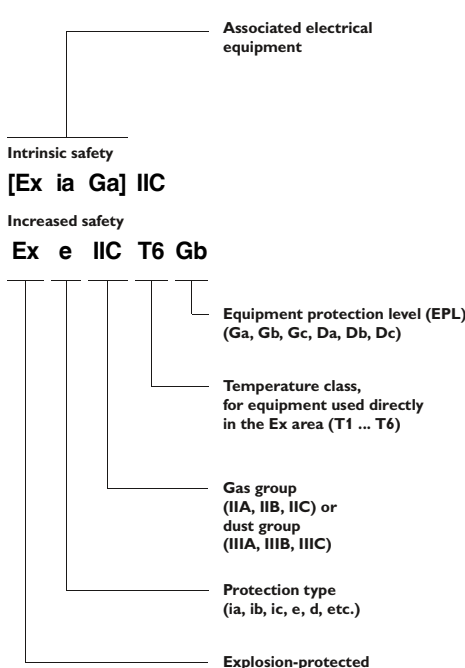

EC-type examination certificate

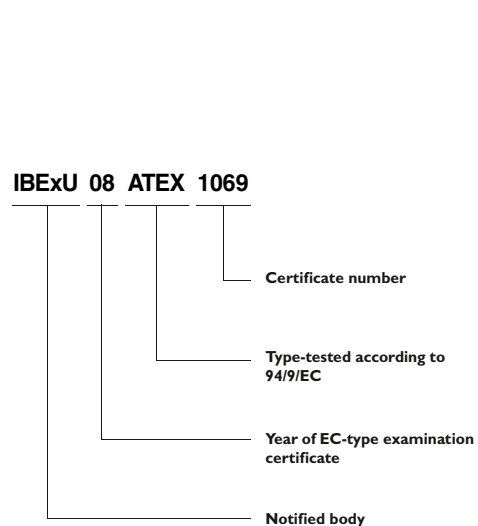

Safety-related function for the Ex area

The term SIL (safety integrity level) is becoming more and more significant in the field of process technology. It defines the requirements that a device or a system is expected to fulfill so that the failure probability can be specified. The aim is to achieve maximum possible operational reliability. If a device or system fails, a defined state is attained. Standard-based inspections are carried out to determine statistical probability.

Application of SIL on the basis of IEC 61508 and IEC 61511

The SIL standard is used for a wide range of industries within the process industry, including the chemical industry, refineries, oil and gas production, paper manufacturing, and conventional power generation. In addition to functional safety requirements, systems in potentially explosive areas are also subject to Ex standards EN 60079-0 ff.

IEC 61508: “Functional safety of electrical/electronic/programmable electronic safety-related systems”

This standard describes the requirements that the manufacturer has to bear in mind when producing devices or systems.

IEC 61511: “Functional safety - Safety instrumented systems for the process industry sector”

The IEC 61511 standard describes the requirements for achieving systems with functional safety.

Compliance with the standard is determined by operators, owners, and planners on the basis of safety plans and national regulations. In addition, the standard also describes the requirements for using a device in an application on the basis of its proven effectiveness (proven in use).



SIL marking on devices

The products in the MACX range from Phoenix Contact, which have been developed according to IEC 61508, are marked with the designation SIL 2 or SIL 3. This indicates clearly that the devices may be suitable for safety instrumented functions (SIF).

To determine whether they can actually be used, you need to calculate the sum of the probability failure values for all the devices in the signal circuit. The necessary values for this can be found in the safety manual of each SIL product.

Overview of terms from SIL standards IEC 61508 and IEC 61511

SIL	Safety Integrity Level One of four discrete levels for the specification of requirements for the safety integrity of safety instrumented functions, which are assigned to the E/E/PE safety instrumented systems, where SIL 4 is the highest and SIL 1 the lowest level.	PFH	Probability of dangerous Failure per Hour Describes the probability of a dangerous failure occurring per hour.
EUC	Equipment Under Control Equipment, machines, devices or systems used in production, materials processing or transport.	SFF	Safe Failure Fraction Describes the proportion of harmless failures. This is the ratio of the rate of safe failures plus the rate of diagnosed or detected faults in relation to the total failure rate of the system.
MTBF	Mean Time Between Failures The expected mean time between failures.	SIF	Safety Instrumented Function Describes the safety instrumented functions of a system.
PFD	Probability of Failure on Demand The probability of a failure on demand. Describes the probability of a safety instrumented system failing to perform its function when required.	SIS	Safety Instrumented System An SIS (safety instrumented system) consists of one or more safety instrumented functions. An SIL requirement is applicable for each of these safety instrumented functions.
PFDavg	Average Probability of Failure on Demand The average probability of the function failing on demand.		
E/E/PE	Electrical/Electronic/Programmable Electronic Systems This term is used for all electrical devices or systems that can be used to execute a safety instrumented function. It includes simple electrical devices and all types of programmable logic controllers (PLCs).		

SIL inspection

The complete signal path must be taken into account during the SIL inspection. The example shows how the safety integrity level is calculated in a typical safety application using average failure probabilities of individual devices.

Table 2 of the IEC 61508-1 standard describes the relationship between the average failure probability and the attainable SIL. Here, the level required determines the overall budget for the sum of all PFD values.

A system with a single-channel structure with a low demand rate is used as an example; for SIL 2 the average PFD value is between 10^{-3} and $< 10^{-2}$.

Safety integrity level SIL	Operating mode with a low demand rate (average probability of the specified function failing on demand)
4	$\geq 10^{-5}$ to $< 10^{-4}$
3	$\geq 10^{-4}$ to $< 10^{-3}$
2	$\geq 10^{-3}$ to $< 10^{-2}$
1	$\geq 10^{-2}$ to $< 10^{-1}$

Safety integrity level: failure limit values for a safety function which is operated in an operating mode with a low demand rate.

Example:

A sensor and actuator are assembled in the field and are exposed to chemical and physical loads (process medium, pressure, temperature, vibration, etc.). Accordingly, these components have a high risk of failure:

- The sensor accounts for 25% of the overall PFD
- The actuator accounts for 40% of the overall PFD

Neither the failsafe controller nor the interface modules come into contact with the process medium and both are usually located in a protected control cabinet:

- The failsafe controller accounts for 15% of the overall PFD
- The interface modules each account for 10% of the overall PFD

Typically, the values form the basis for a calculation.

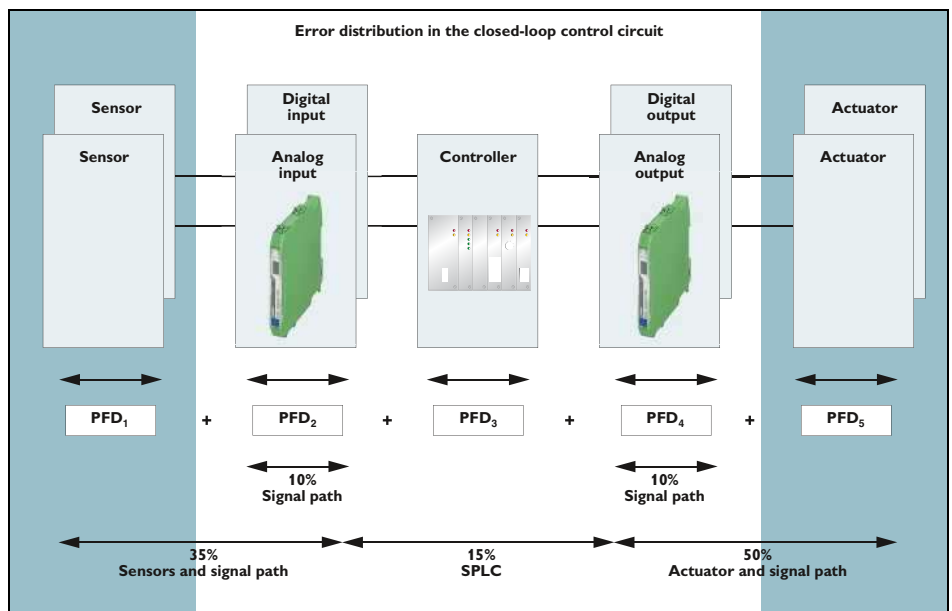

Functional safety performance level (PL) according to EN ISO 13849-1 and EN 62061

General information

In modern industrial systems, the amount of complex technical equipment used is constantly increasing. The purpose of safety technology is to reduce the risk as far as possible but at least to a reasonable degree. At the same time, the availability of production equipment should not be restricted any more than is absolutely necessary.

The Machinery Directive defines the requirements machinery must meet before it can be placed on the market and operated in the European Economic Area. It also contains essential health and safety requirements for the planning and construction of machinery and safety components.

However, the number of systems subject to the directive that do not belong to classical machine building is increasing continually. These include, for example, wind turbine generators. However, biogas systems, distributed energy generation generally, and other process engineering systems also focus on the statutory requirements.

For this reason, analog signals are increasingly being handled according to the specifications of the Machinery Directive.

Every “machine” or system poses a risk. According to the requirements of the Machinery Directive, a risk assessment must be carried out for every machine. If the risk is greater than the level of risk that can be tolerated, risk reduction must be implemented.

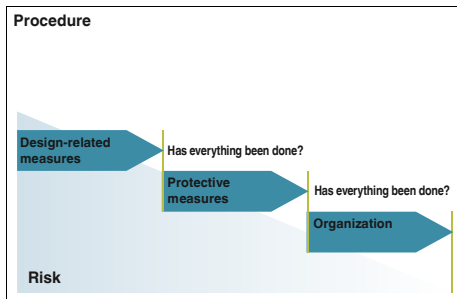

Figure 1: Risk reduction according to EN ISO 12100

Functional safety

In order to achieve the necessary “functional safety” of a system, it is essential for the safety-related parts of the safety equipment and control devices to operate correctly and, in the event of failure, for the system to remain in the safe state or enter a safe state. The requirements for achieving functional safety are based on the following objectives:

- Avoidance of systematic errors
- Control of systematic errors
- Control of random faults or failures

The EN ISO 13849 (and EN 62061) standard specifies the various safety levels in the form of the Performance Level “PL” (and the Safety Integrity Level “SIL”) depending on the extent of the risk and describes the characteristics of the safety functions.

Practical procedure according to EN ISO 13849

In practice, the following steps have proved to be effective:

1. Definition of the safety function
The information is derived from the risk assessment.
2. Determination of the required Performance Level (PL)
For each safety function, the required performance level is estimated using the adjacent risk graph (Fig. 3).
3. Technical implementation
This step involves the technical pre-planning of the safety function, taking possible technologies and components into account.
4. Dividing the safety function into subsystems
Implementation takes place in block diagrams. As a rule, a safety function consists of a sensor-logic actuator.

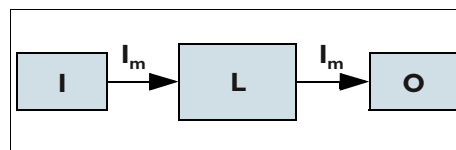

Figure 2: Safety technology block diagram (according to EN 13849-1)

5. Determination of the achieved PL for each subsystem
A characteristic value when determining the performance level is the so-called PFHd value, the statistical “probability of a dangerous failure per hour”. The safety technology characteristics are given in the product data sheet, the FUNCTIONAL

SAFETY CHARACTERISTICS data sheet or the SISTEMA library (Fig. 4).

Further safety technology characteristic data consists of the category, the DC value, and the MTTFD value (Fig. 5).

6. Determination of the achieved PL
The manufacturer of subsystems states the category and makes the specifications on the achieved PFHd value and the PL available.
7. Verification of the achieved PL
Each individual subsystem and the entire safety chain must together meet the requirements of the necessary PL. This includes both the quantitative evaluation and the consideration of systematic aspects, such as proven components and safety principles.
8. Validation
Finally, it is necessary to check whether the selected measures achieve the required risk reduction and therefore the protection objectives of the risk assessment. The result is included in the final risk assessment.

Definitions:

- PFH_D: probability of a dangerous failure occurring per hour.
- DC: diagnostic coverage
- MTTF_d: mean time to dangerous failure

Category:

- B10_d: number of operating cycles after which 10% of the devices have failed
- CCF: Common cause failure

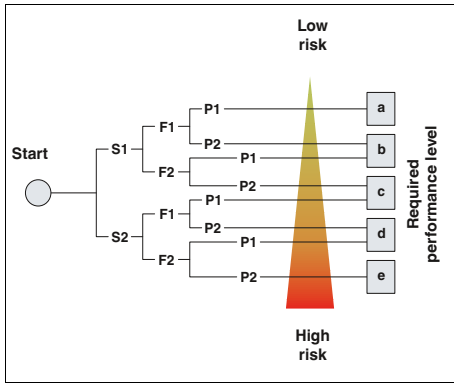

Figure 3: Risk graph

Meaning of individual parameters:

S: Severity of injury

– S1: Slight (reversible) injuries

– S2: Severe (irreversible) injuries

F: Frequency and duration of exposure to the hazard

– F1: Seldom to not very frequent

– F2: Frequent to continually or long

P: Possibility of avoiding or limiting damage

– P1: Possible under certain conditions

– P2: Hardly possible



Phoenix Contact offers a series of services surrounding the topic of functional safety.

It comprises initial planning and startup to the modernization of the safety lifecycle. There is also a training concept. Dates are published on the homepage.

In addition, all questions are answered via the free safety hotline.

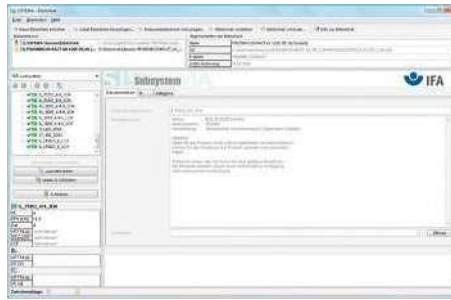

Figure 4: SISTEMA library

SISTEMA is a product library with which safety functions can be easily calculated. The products from MACX Safety and MACX Safety Ex are included in a SISTEMA library. It is available from the product download area on the Phoenix Contact homepage.

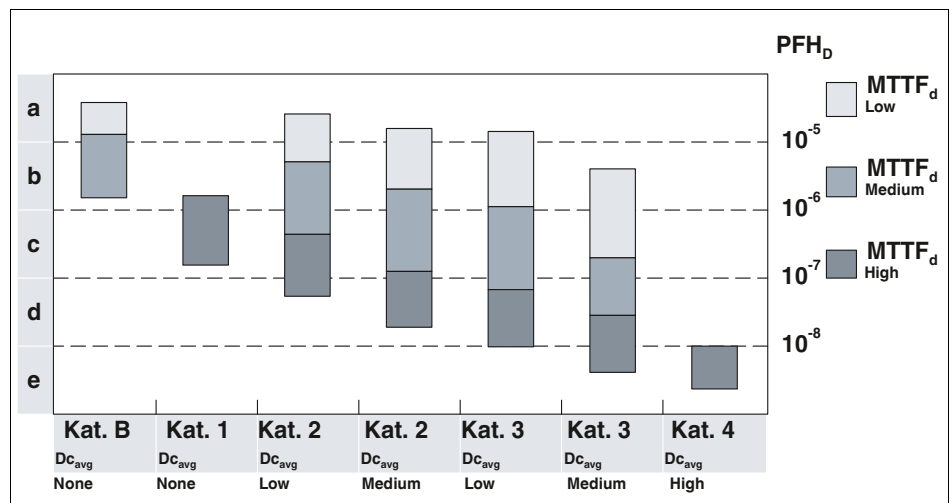
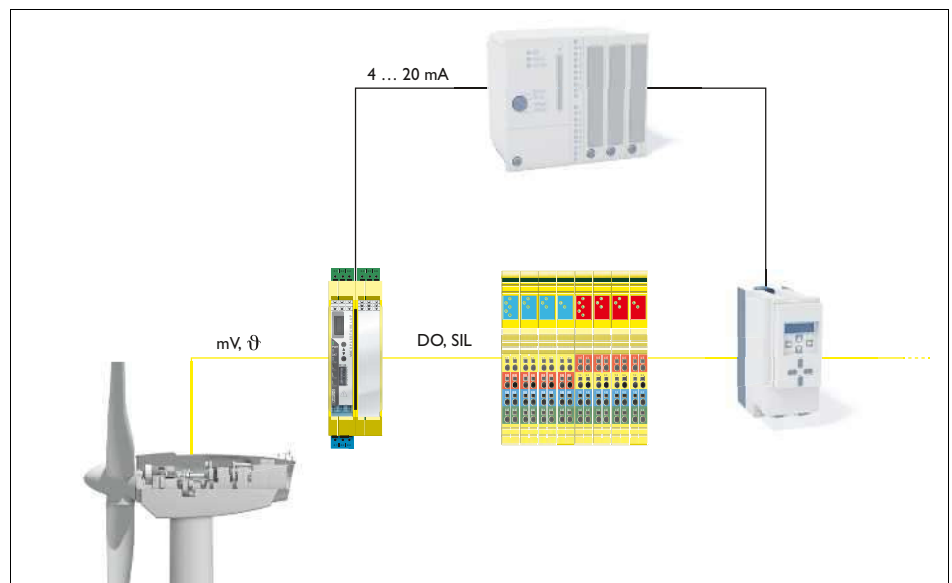
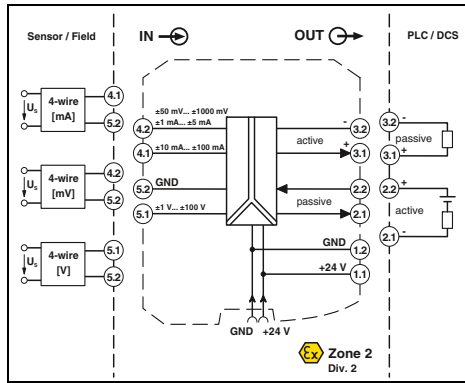
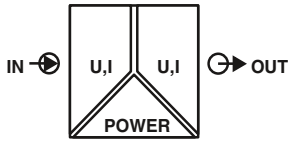

Figure 5: Relationship between PL, category, DC, and MTTFd (according to EN 13849-1)



Application example:
Safety-related temperature monitoring in a wind turbine generator

Analog IN/Analog OUT
3-way signal conditioner



Ex n



SIL IEC 61508



Universal, more than 1600 signal combinations

Functional Safety

Ex: Ex n

Housing width 12.5 mm

Technical data

Input data	Input signal (configurable using the DIP switch)
Maximum input signal	±50 mV... ±1000 mV ±1 mA... ±5 mA
Input resistance	±10 mA... ±100 mA
Output data	Output signal (configurable using the DIP switch)
Load R _B	≥ 1 kΩ (10 V)
General data	Supply voltage range Power dissipation Maximum transmission error Temperature coefficient ZERO / SPAN adjustment Limit frequency (3 dB) Step response (10-90%)
Electrical isolation	Input/output/power supply
Test voltage, input/output/supply	2.5 kV (50 Hz, 1 min., test voltage)
Degree of protection	IP20
Ambient temperature (operation)	-20 °C ... 70 °C
Mounting	any
Housing material	PA 66-FR
Dimensions W/H/D	12.5 / 99 / 114.5 mm
Screw connection solid/stranded/AWG	0.2 ... 2.5 mm ² / 0.2 ... 2.5 mm ² / 24 - 14
Push-in connection solid/stranded/AWG	0.2 ... 1.5 mm ² / 0.2 ... 1.5 mm ² / 24 - 16
EMC note	Class A product, see page 605
Conformance/Approvals	CE-compliant Ex II 3 G Ex nA IIC T4 Gc Ex nA IIC T4 Gc UL 61010 Listed Class I, Div. 2, Groups A, B, C, D T6 Class I, Zone 2, Group IIC 2
SIL in accordance with IEC 61508	

U input	0 ... 10 V , please indicate if different setting when ordering
I input	0 ... 1 mA , Configurable via DIP switches
± 100 V	± 100 mA
approx. 1 MΩ (± 1 V DC ... ± 100 V DC)	approx. 10 Ω (± 10 mA DC ... ± 100 mA DC)
U output	0 ... 10 V , Configurable via DIP switches
I output	0 ... 20 mA , please indicate if different setting when ordering
≥ 1 kΩ (10 V)	≤ 600 Ω (20 mA: active) passive: ≤ (UB-2 V) / I _{outmax}
12 V DC ... 24 V DC (-20 % / +25 %)	
< 0.7 W (at 24 V DC / 20 mA)	
≤ 0.1 % (Compared to the final value)	
0.0075 %/K	
± 4 % / ± 4 %	
10 kHz (Can be switched to 30 Hz)	
35 μs (at 10 kHz)	
11 ms (At 30 Hz)	
2.5 kV (50 Hz, 1 min., test voltage)	
300 V _{rms} (Rated insulation voltage (overvoltage category II; degree of pollution 2, safe isolation as per EN 61010-1))	

Universal signal conditioner for operating 4-conductor measuring transducers.

- Analog signal conditioner for isolating, filtering, amplifying, and converting standard analog signals
- Configurable input and output signals, including bipolar current and voltage signals
- 3-way electrical isolation
- Over 1600 signal conversions can be set via DIP switches on the front
- 10 kHz limit frequency for time-critical applications
- Output active or passive
- Plug-in screw or Push-in connection technology
- Power supply via DIN rail connector possible
- Status indicator for supply voltage
- Up to SIL 2 according to IEC 61508
- Installation in Zone 2 permitted

Notes:
To order a product with an order configuration, enter the required configuration by referring to the adjacent order key.
Information about the supply and error evaluation module as well as about the DIN rail connectors and marking material can be found from page 174

Description	3-way signal conditioner , for electrical isolation of analog signals
Order configuration	Screw connection
Order configuration	Push-in connection
Standard configuration	Screw connection
Standard configuration	Push-in connection

Ordering data		
Type	Order No.	Pcs./ Pkt.
MACX MCR-UI-UI	2811284	1
MACX MCR-UI-UI-SP	2811572	1
MACX MCR-UI-UI-NC	2811446	1
MACX MCR-UI-UI-SP-NC	2811556	1

Order key for MACX MCR-UI-UI(-SP) (standard configuration entered as an example)

Order No.	Input	Output	Cut-off frequency	Factory calibration certificate (FCC)	
2811284	IN03	OUT01	10K	NONE	
2811284 ≙ MACX MCR-UI-UI	IN40 ≙ 0 ... 50 mV IN24 ≙ 0 ... 60 mV IN41 ≙ 0 ... 75 mV IN25 ≙ 0 ... 100 mV IN43 ≙ 0 ... 120 mV IN44 ≙ 0 ... 150 mV IN26 ≙ 0 ... 200 mV IN27 ≙ 0 ... 300 mV IN28 ≙ 0 ... 500 mV IN66 ≙ 0 ... 1000 mV IN29 ≙ 0 ... 1.0 V IN50 ≙ 0 ... 1.5 V IN30 ≙ 0 ... 2.0 V IN52 ≙ 0 ... 3.0 V IN05 ≙ 0 ... 5 V IN03 ≙ 0 ... 10 V IN67 ≙ 0 ... 15 V IN32 ≙ 0 ... 20 V IN39 ≙ 0 ... 30 V IN68 ≙ 0 ... 50 V IN69 ≙ 0 ... 100 V IN06 ≙ 1 ... 5 V IN04 ≙ 2 ... 10 V	IN53 ≙ -50 ... +50 mV IN13 ≙ -60 ... +60 mV IN54 ≙ -75 ... +75 mV IN14 ≙ -100 ... +100 mV IN56 ≙ -120 ... +120 mV IN57 ≙ -150 ... +150 mV IN15 ≙ -200 ... +200 mV IN16 ≙ -300 ... +300 mV IN17 ≙ -500 ... +500 mV IN78 ≙ -1000 ... +1000 mV IN18 ≙ -1.0 ... +1.0 V IN63 ≙ -1.5 ... +1.5 V IN19 ≙ -2.0 ... +2.0 V IN65 ≙ -3.0 ... +3.0 V IN21 ≙ -5 ... +5 V IN22 ≙ -10 ... +10 V IN79 ≙ -15 ... +15 V IN23 ≙ -20 ... +20 V IN80 ≙ -30 ... +30 V IN81 ≙ -50 ... +50 V IN82 ≙ -100 ... +100 V IN70 ≙ 0 ... 1.0 mA IN71 ≙ 0 ... 1.5 mA IN72 ≙ 0 ... 2.0 mA IN73 ≙ 0 ... 3.0 mA IN36 ≙ 0 ... 5 mA IN37 ≙ 0 ... 10 mA IN74 ≙ 0 ... 15 mA IN01 ≙ 0 ... 20 mA IN75 ≙ 0 ... 30 mA IN76 ≙ 0 ... 50 mA IN77 ≙ 0 ... 100 mA IN83 ≙ -1.0 ... +1.0 mA IN84 ≙ -1.5 ... +1.5 mA IN85 ≙ -2.0 ... +2.0 mA IN86 ≙ -3.0 ... +3.0 mA IN33 ≙ -5 ... +5 mA IN34 ≙ -10 ... +10 mA IN87 ≙ -15 ... +15 mA IN35 ≙ -20 ... +20 mA IN88 ≙ -30 ... +30 mA IN89 ≙ -50 ... +50 mA IN90 ≙ -100 ... +100 mA IN91 ≙ 1 ... 5 mA IN92 ≙ 2 ... 10 mA IN02 ≙ 4 ... 20 mA	OUT19 ≙ 0 ... 2.5 V OUT05 ≙ 0 ... 5 V OUT03 ≙ 0 ... 10 V OUT20 ≙ -2.5 ... +2.5 V OUT13 ≙ -5 ... +5 V OUT14 ≙ -10 ... +10 V OUT24 ≙ 0.5 ... +2.5 V OUT06 ≙ 1 ... 5 V OUT04 ≙ 2 ... 10 V OUT27 ≙ 2.5 ... 0 V OUT11 ≙ 5 ... 0 V OUT09 ≙ 10 ... 0 V	OUT15 ≙ 0 ... 5 mA OUT16 ≙ 0 ... 10 mA OUT01 ≙ 0 ... 20 mA OUT21 ≙ -5 ... +5 mA OUT22 ≙ -10 ... +10 mA OUT23 ≙ -20 ... +20 mA OUT25 ≙ 1 ... 5 mA OUT26 ≙ 2 ... 10 mA OUT02 ≙ 4 ... 20 mA OUT28 ≙ 5 ... 0 mA OUT29 ≙ 10 ... 0 mA OUT07 ≙ 20 ... 0 mA	30 ≙ 30 Hz 10K ≙ 10 kHz NONE ≙ Without FCC YES ≙ With FCC (a fee is charged) YESPLUS ≙ FCC with 5 measuring points (a fee is charged)

Application example: Level measurement and active analog input card

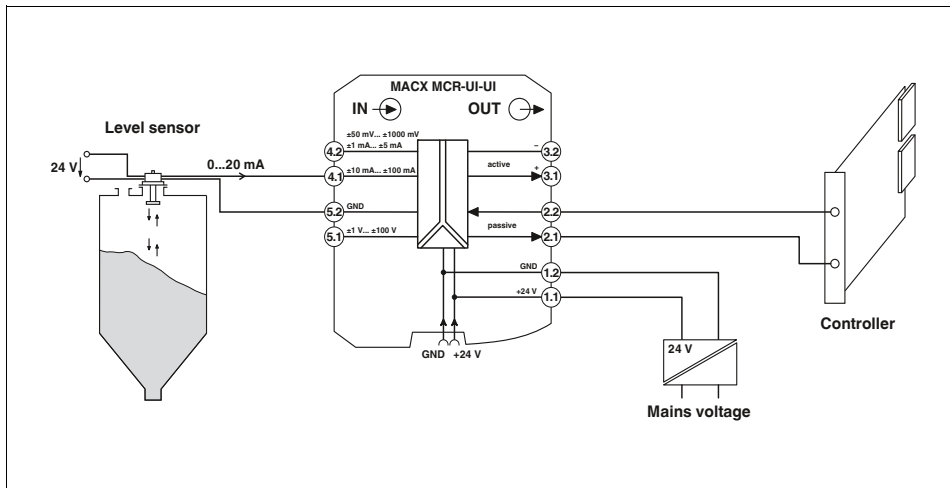

Application example: Shunt measurement and Inline terminal with passive analog input channels within an Inline station

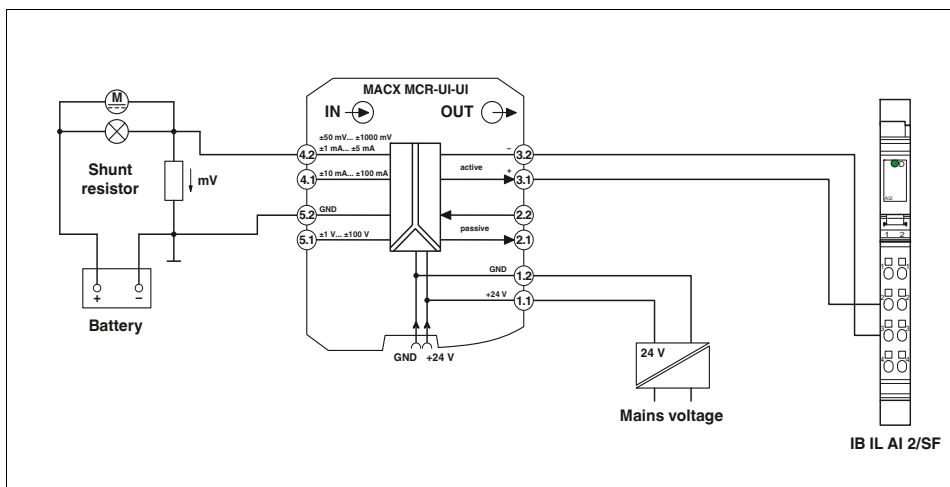

(Information on automation solutions from Phoenix Contact can be found in Catalog 6 or at phoenixcontact.net/products)

Analog IN/Analog OUT
3-way signal conditioner

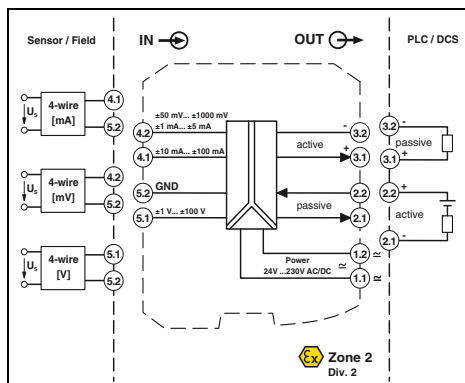
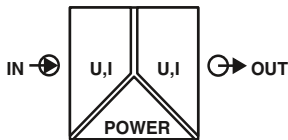

Ex n



Universal, more than 1600 signal combinations,
wide-range power supply



FAC DNV GL Functional Safety

Ex: Ex n

Housing width 12.5 mm

Technical data

Input data	Input signal (configurable using the DIP switch)
Maximum input signal	
Input resistance	
Output data	Output signal (configurable using the DIP switch)
Maximum output signal	
Load R_B	
General data	Supply voltage range
	Power dissipation
Maximum transmission error	
Temperature coefficient	
ZERO / SPAN adjustment	
Electrical isolation	Input/output/power supply
Degree of protection	
Ambient temperature (operation)	
Housing material	
Dimensions W/H/D	
Screw connection solid/stranded/AWG	
Push-in connection solid/stranded/AWG	
EMC note	
Conformance/Approvals	
Conformance	
ATEX	
SIL in accordance with IEC 61508	

U input	0 ... 10 V , please indicate if different setting when ordering	I input	0 ... 1 mA , Configurable via DIP switches
	± 100 V		± 100 mA
	approx. 1 M Ω		approx. 10 Ω
	(± 1 V DC ... ± 100 V DC)		(± 10 mA DC ... ± 100 mA DC)
U output	0 ... 10 V , Configurable via DIP switches	I output	0 ... 20 mA , Configurable via DIP switches
	15 V		35 mA
	≥ 1 k Ω (10 V)		≤ 600 Ω (20 mA: active)
			passive: $\leq (U_B - 2$ V) / I_{outmax}
	24 V ... 230 V AC/DC (-20 %/+10 % , 50/60 Hz)		
	< 0.8 W (at 24 V DC / 20 mA)		
	< 0.9 W (At 230 V AC / 20 mA)		
	≤ 0.1 % (Compared to the final value)		
	0.0075 %/K		
	± 4 % / ± 4 %		
	2.5 kV (50 Hz, 1 min., test voltage)		
	300 V _{rms} (Rated insulation voltage (overvoltage category II; degree of pollution 2, safe isolation as per EN 61010-1))		
	IP20		
	-20 °C ... 70 °C		
	PA 66-FR		
	12.5 / 99 / 114.5 mm		
	0.2 ... 2.5 mm ² / 0.2 ... 2.5 mm ² / 24 - 14		
	0.2 ... 1.5 mm ² / 0.2 ... 1.5 mm ² / 24 - 16		
	Class A product, see page 605		
	CE-compliant		
	Ex II 3 G Ex nA IIC T4 Gc		
	2		

- Analog signal conditioner for isolating, filtering, amplifying, and converting standard analog signals
- Configurable input and output signals, including bipolar current and voltage signals
- 3-way electrical isolation
- Over 1600 signal conversions can be set via DIP switches on the front
- Output active or passive
- Plug-in screw or Push-in connection technology
- Wide-range power supply of 19.2 to 253 V AC/DC
- Status indicator for supply voltage
- Up to SIL 2 according to IEC 61508
- Installation in Zone 2 permitted

Notes:
To order a product with an order configuration, enter the required configuration by referring to the adjacent order key.

Ordering data

Description	Type	Order No.	Pcs./Pkt.
3-way signal conditioner , for electrical isolation of analog signals with wide-range power supply			
Order configuration	Screw connection	MACX MCR-UI-UI-UP	2811459
Order configuration	Push-in connection	MACX MCR-UI-UI-UP-SP	2811585
Standard configuration	Screw connection	MACX MCR-UI-UI-UP-NC	2811297
Standard configuration	Push-in connection	MACX MCR-UI-UI-UP-SP-NC	2811569

Order key for MACX MCR-UI-UI(-SP) (standard configuration entered as an example)

Order No.	Input	Output	Cut-off frequency	Factory calibration certificate (FCC)		
2811459	IN03	OUT01	10K	NONE		
2811459 ≙ MACX MCR-UI-UI-UP	IN40 ≙ 0 ... 50 mV IN24 ≙ 0 ... 60 mV IN41 ≙ 0 ... 75 mV IN25 ≙ 0 ... 100 mV IN43 ≙ 0 ... 120 mV IN44 ≙ 0 ... 150 mV IN26 ≙ 0 ... 200 mV IN27 ≙ 0 ... 300 mV IN28 ≙ 0 ... 500 mV IN66 ≙ 0 ... 1000 mV IN29 ≙ 0 ... 1.0 V IN50 ≙ 0 ... 1.5 V IN30 ≙ 0 ... 2.0 V IN52 ≙ 0 ... 3.0 V IN05 ≙ 0 ... 5 V IN03 ≙ 0 ... 10 V IN67 ≙ 0 ... 15 V IN32 ≙ 0 ... 20 V IN39 ≙ 0 ... 30 V IN68 ≙ 0 ... 50 V IN69 ≙ 0 ... 100 V IN06 ≙ 1 ... 5 V IN04 ≙ 2 ... 10 V	IN53 ≙ -50 ... +50 mV IN13 ≙ -60 ... +60 mV IN54 ≙ -75 ... +75 mV IN14 ≙ -100 ... +100 mV IN56 ≙ -120 ... +120 mV IN57 ≙ -150 ... +150 mV IN15 ≙ -200 ... +200 mV IN16 ≙ -300 ... +300 mV IN17 ≙ -500 ... +500 mV IN78 ≙ -1000 ... +1000 mV IN18 ≙ -1.0 ... +1.0 V IN63 ≙ -1.5 ... +1.5 V IN19 ≙ -2.0 ... +2.0 V IN65 ≙ -3.0 ... +3.0 V IN21 ≙ -5 ... +5 V IN22 ≙ -10 ... +10 V IN79 ≙ -15 ... +15 V IN23 ≙ -20 ... +20 V IN80 ≙ -30 ... +30 V IN81 ≙ -50 ... +50 V IN82 ≙ -100 ... +100 V IN70 ≙ 0 ... 1.0 mA IN71 ≙ 0 ... 1.5 mA IN72 ≙ 0 ... 2.0 mA IN73 ≙ 0 ... 3.0 mA IN36 ≙ 0 ... 5 mA IN37 ≙ 0 ... 10 mA IN74 ≙ 0 ... 15 mA IN01 ≙ 0 ... 20 mA IN75 ≙ 0 ... 30 mA IN76 ≙ 0 ... 50 mA IN77 ≙ 0 ... 100 mA IN83 ≙ -1.0 ... +1.0 mA IN84 ≙ -1.5 ... +1.5 mA IN85 ≙ -2.0 ... +2.0 mA IN86 ≙ -3.0 ... +3.0 mA IN33 ≙ -5 ... +5 mA IN34 ≙ -10 ... +10 mA IN87 ≙ -15 ... +15 mA IN35 ≙ -20 ... +20 mA IN88 ≙ -30 ... +30 mA IN89 ≙ -50 ... +50 mA IN90 ≙ -100 ... +100 mA IN91 ≙ 1 ... 5 mA IN92 ≙ 2 ... 10 mA IN02 ≙ 4 ... 20 mA	OUT19 ≙ 0 ... 2.5 V OUT05 ≙ 0 ... 5 V OUT03 ≙ 0 ... 10 V OUT20 ≙ -2.5 ... +2.5 V OUT13 ≙ -5 ... +5 V OUT14 ≙ -10 ... +10 V OUT24 ≙ 0.5 ... +2.5 V OUT06 ≙ 1 ... 5 V OUT04 ≙ 2 ... 10 V OUT27 ≙ 2.5 ... 0 V OUT11 ≙ 5 ... 0 V OUT09 ≙ 10 ... 0 V	OUT15 ≙ 0 ... 5 mA OUT16 ≙ 0 ... 10 mA OUT01 ≙ 0 ... 20 mA OUT21 ≙ -5 ... +5 mA OUT22 ≙ -10 ... +10 mA OUT23 ≙ -20 ... +20 mA OUT25 ≙ 1 ... 5 mA OUT26 ≙ 2 ... 10 mA OUT02 ≙ 4 ... 20 mA OUT28 ≙ 5 ... 0 mA OUT29 ≙ 10 ... 0 mA OUT07 ≙ 20 ... 0 mA	30 ≙ 30 Hz 10K ≙ 10 kHz	NONE ≙ Without FCC YES ≙ With FCC (a fee is charged) YESPLUS ≙ FCC with 5 measuring points (a fee is charged)

Application example: Level measurement and active analog input card

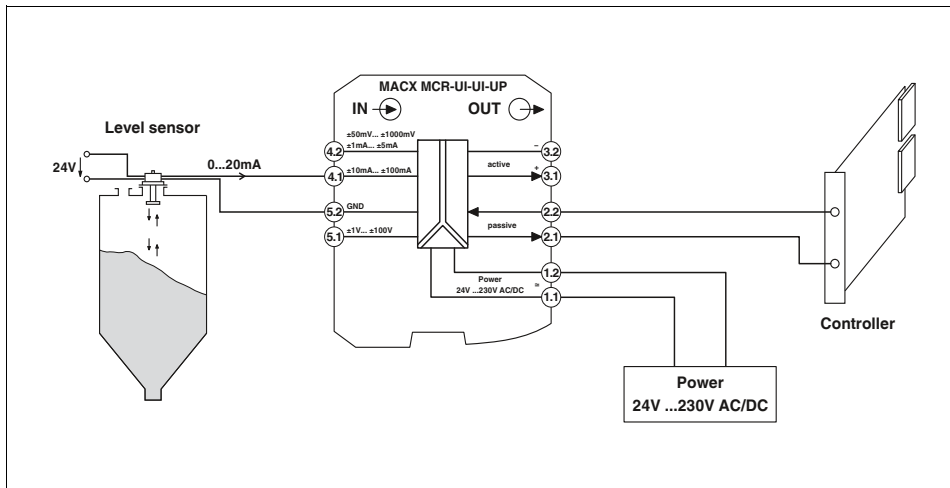

Application example: Shunt measurement and Inline terminal with analog input channels within an Inline station

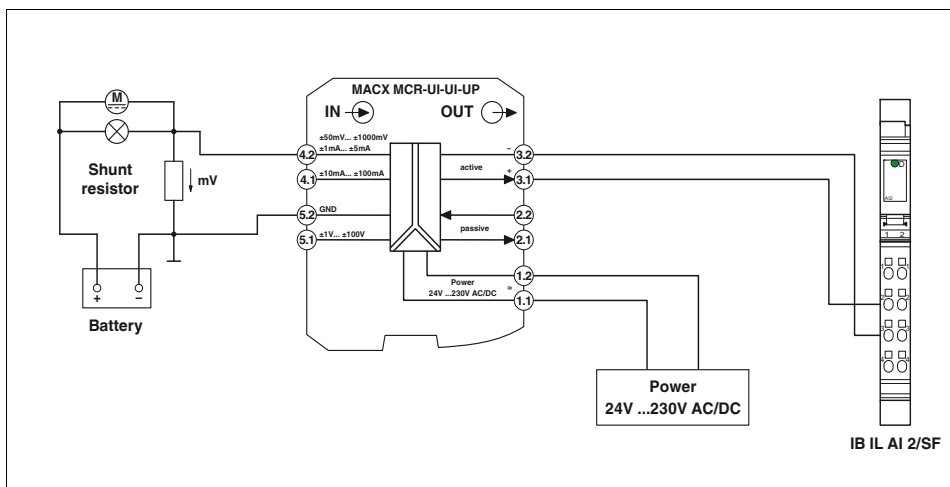

(Information on automation solutions from Phoenix Contact can be found in Catalog 6 or at phoenixcontact.net/products)

Analog IN / Analog OUT
repeater power supplies

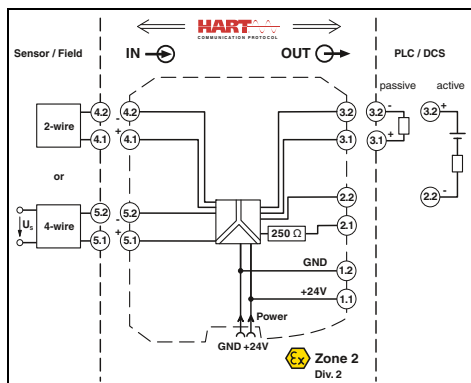
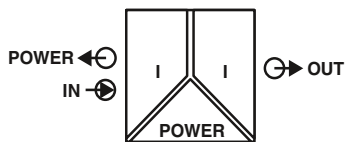

Repeater power supply and input signal conditioner

Functional Safety Ex

SIL IEC 61508
Housing width 12.5 mm

Repeater power supply and input signal conditioner for the operation of 2-wire measuring transducers, 4-wire measuring transducers, and mA current sources

- 0/4 to 20 mA input (powered or not powered)
- 0/4 to 20 mA output (active or passive)
- Bidirectional transmission of digital HART communication signals
- Plug-in screw or Push-in connection technology, with integrated sockets for HART communicators
- Terminal point with 250 Ω resistor to increase the HART impedance in the case of low-impedance systems
- 3-way electrical isolation
- Power supply via DIN rail connector possible
- Up to SIL 2 according to IEC 61508
- Installation in Zone 2 permitted

Input data	
Input signal	4 mA ... 20 mA
Transmitter supply voltage	> 21.5 V (20 mA)
Voltage drop	< 3.5 V (in input signal conditioner operation)
Output data	
Output signal	4 mA ... 20 mA (active) 4 mA ... 20 mA (14 ... 26 V ext. source voltage)
Load	< 1000 Ω (20 mA)
Output ripple	< 20 mV _{rms}
General data	
Supply voltage range	19.2 V DC ... 30 V DC (24 V DC -20%...+25%)
Current consumption	< 76 mA (24 V DC / 20 mA / 1000 Ω) ; < 55 mA (24 V DC / 20 mA / 250 Ω)
Power dissipation	< 1.1 W (24 V DC / 20 mA) < 0.95 W (24 V DC / 20 mA / 250 Ω) < 1.2 W (24 V DC / 20 mA / 0 Ω)
Temperature coefficient	< 0.01 %/K
Step response (10-90%)	< 200 μs (for jump 4 mA ... 20 mA, load 600)
Transmission error, typical	< 0.05 % (of final value)
Maximum transmission error	< 0.1 % (of final value)
Under-/overload range	according to NE 43
Electrical isolation	
Input/output/power supply	300 V _{rms} (Rated insulation voltage (overvoltage category II; degree of pollution 2, safe isolation as per EN 61010-1)) 2.5 kV (50 Hz, 1 min., test voltage)
Ambient temperature range	-20 °C ... 60 °C (Any mounting position)
Status indication	Green LED (supply voltage)
SMART communication	Yes
Signal bandwidth	as per HART specifications
Protocols supported	HART
Housing material	PA 66-FR
Dimensions W/H/D	12.5 / 112.5 / 114.5 mm
Screw connection solid/stranded/AWG	0.2 ... 2.5 mm ² / 0.2 ... 2.5 mm ² / 24 - 14
Push-in connection solid/stranded/AWG	0.2 ... 1.5 mm ² / 0.2 ... 1.5 mm ² / 24 - 16
EMC note	Class A product, see page 605
Conformance/Approvals	
Conformance	CE-compliant, additionally EN 61326
ATEX	Ex II 3 G Ex nA II T4 Gc X
UL, USA/Canada	UL 61010 Listed UL 508 Listed Class I, Div. 2, Groups A, B, C, D T4 Class I, Zone 2, Group IIC T4

SIL in accordance with IEC 61508

Notes:
Information about the supply and error evaluation module as well as about the DIN rail connectors and marking material can be found from page 174
Test plugs for test sockets can be found on page 176
Information on "Plug and play" connection using system cabling can be found from page 164

Technical data

Input data	
Input signal	4 mA ... 20 mA
Transmitter supply voltage	> 21.5 V (20 mA)
Voltage drop	< 3.5 V (in input signal conditioner operation)
Output data	
Output signal	4 mA ... 20 mA (active) 4 mA ... 20 mA (14 ... 26 V ext. source voltage)
Load	< 1000 Ω (20 mA)
Output ripple	< 20 mV _{rms}
General data	
Supply voltage range	19.2 V DC ... 30 V DC (24 V DC -20%...+25%)
Current consumption	< 76 mA (24 V DC / 20 mA / 1000 Ω) ; < 55 mA (24 V DC / 20 mA / 250 Ω)
Power dissipation	< 1.1 W (24 V DC / 20 mA) < 0.95 W (24 V DC / 20 mA / 250 Ω) < 1.2 W (24 V DC / 20 mA / 0 Ω)
Temperature coefficient	< 0.01 %/K
Step response (10-90%)	< 200 μs (for jump 4 mA ... 20 mA, load 600)
Transmission error, typical	< 0.05 % (of final value)
Maximum transmission error	< 0.1 % (of final value)
Under-/overload range	according to NE 43
Electrical isolation	
Input/output/power supply	300 V _{rms} (Rated insulation voltage (overvoltage category II; degree of pollution 2, safe isolation as per EN 61010-1)) 2.5 kV (50 Hz, 1 min., test voltage)
Ambient temperature range	-20 °C ... 60 °C (Any mounting position)
Status indication	Green LED (supply voltage)
SMART communication	Yes
Signal bandwidth	as per HART specifications
Protocols supported	HART
Housing material	PA 66-FR
Dimensions W/H/D	12.5 / 112.5 / 114.5 mm
Screw connection solid/stranded/AWG	0.2 ... 2.5 mm ² / 0.2 ... 2.5 mm ² / 24 - 14
Push-in connection solid/stranded/AWG	0.2 ... 1.5 mm ² / 0.2 ... 1.5 mm ² / 24 - 16
EMC note	Class A product, see page 605
Conformance/Approvals	
Conformance	CE-compliant, additionally EN 61326
ATEX	Ex II 3 G Ex nA II T4 Gc X
UL, USA/Canada	UL 61010 Listed UL 508 Listed Class I, Div. 2, Groups A, B, C, D T4 Class I, Zone 2, Group IIC T4

Ordering data

Description	Type	Order No.	Pcs./Pkt.	
Repeater power supply, with HART® protocol	Screw connection	MACX MCR-SL-RPSSI-I	2865955	1
	Push-in connection	MACX MCR-SL-RPSSI-I-SP	2924207	1

Analog IN / Analog OUT
repeater power supplies

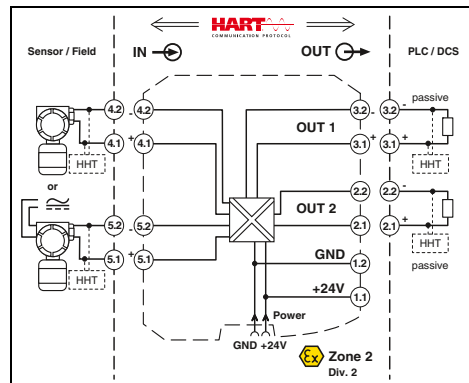
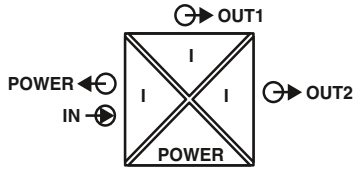

Ex n



SIL IEC 61508



Repeater power supply and input signal conditioner, with two electrically isolated outputs

Functional Safety

Ex: Ex n

Housing width 12.5 mm

Technical data

Input data		
Input signal		4 mA ... 20 mA / 0 mA ... 20 mA
Transmitter supply voltage		> 21.5 V (24 mA)
Voltage drop		< 3.9 V (in input signal conditioner operation)
Output data		
Output signal (Per output)		4 mA ... 20 mA (active)
		0 mA ... 20 mA
		< 450 Ω (20 mA)
		< 20 mV _{rms}
Load		
Output ripple		
General data		
Supply voltage range		19.2 V DC ... 30 V DC (24 V DC -20%...+25%)
Current consumption		< 75 mA (24 V DC / 20 mA)
Power dissipation		< 1.45 W (24 V DC / 20 mA)
Temperature coefficient		< 0.01 %/K
Step response (10-90%)		1.3 ms (for jump 4 mA ... 20 mA, typical)
Transmission error, typical		< 0.05 % (of final value)
Maximum transmission error		< 0.1 % (of final value)
Under-/overload range		according to NE 43
Electrical isolation	Input/output/power supply	300 V _{rms} (Rated insulation voltage (overvoltage category II; degree of pollution 2, safe isolation as per EN 61010-1)) 2.5 kV (50 Hz, 1 min., test voltage)
	Output 1/output 2	1.5 kV AC (50 Hz, 1 min., test voltage)
Ambient temperature range		-20 °C ... 60 °C (Any mounting position) -20 °C ... 70 °C (any mounting position, module distance > 5 mm, MTBF reduction factor 2.5, not assessed by UL)
Status indication		Green LED (PWR supply voltage)
SMART communication (Per output)		Yes
Protocols supported		HART
Housing material		PA 66-FR
Dimensions W/H/D		12.5 / 99 / 114.5 mm
Screw connection solid/stranded/AWG		0.2 ... 2.5 mm ² / 0.2 ... 2.5 mm ² / 24 - 14
Push-in connection solid/stranded/AWG		0.2 ... 1.5 mm ² / 0.2 ... 1.5 mm ² / 24 - 16
EMC note		Class A product, see page 605
Conformance/Approvals		
Conformance		CE-compliant, additionally EN 61326-1
ATEX		Ex II 3 G Ex nA IIC T4 Gc X
SIL in accordance with IEC 61508		2

Repeater power supply and input signal conditioner for the operation of 2-wire measuring transducers, 4-wire measuring transducers, and mA current sources

- 0/4 to 20 mA input (powered or not powered)
- Two electrically isolated outputs, 0/4 to 20 mA (active)
- Bidirectional transmission of digital HART communication signals (both outputs)
- Plug-in screw or Push-in connection technology, with integrated sockets for HART communicators
- 4-way electrical isolation
- Power supply via DIN rail connector possible
- Up to SIL 2 according to IEC 61508
- Installation in Zone 2 permitted

Notes:

Information about the supply and error evaluation module as well as about the DIN rail connectors and marking material can be found from page 174

Test plugs for test sockets can be found on page 176

Information on "Plug and play" connection using system cabling can be found from page 164

Ordering data

Description	Type	Order No.	Pcs./Pkt.	
Repeater power supply, with HART® protocol	Screw connection	MACX MCR-SL-RPSSI-2I	2924825	1
	Push-in connection	MACX MCR-SL-RPSSI-2I-SP	2924838	1

Analog IN / Analog OUT
repeater power supplies

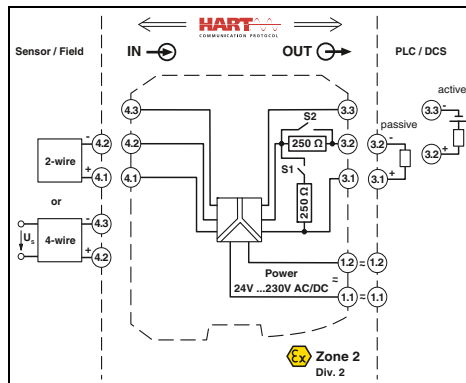
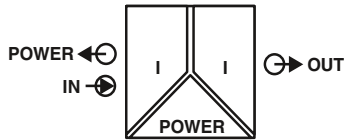

Ex n



Repeater power supply and input signal conditioner, wide-range power supply

Functional Safety

Ex: Ex n

Housing width 17.5 mm

Technical data

Input data	Input signal Transmitter supply voltage Voltage drop
Output data	Output signal
Load	Output ripple
General data	Supply voltage range
Current consumption	Power dissipation Temperature coefficient Step response (10-90%) Transmission error, typical Maximum transmission error Under-/overload range Electrical isolation
Ambient temperature range	Status indication SMART communication Signal bandwidth Protocols supported Housing material Dimensions W/H/D Screw connection solid/stranded/AWG Push-in connection solid/stranded/AWG EMC note
Conformance/Approvals	Conformance ATEX UL, USA/Canada
SIL in accordance with IEC 61508	

4 mA ... 20 mA > 16 V (20 mA) < 3.5 V (in input signal conditioner operation)
4 mA ... 20 mA (active) 4 mA ... 20 mA (14 ... 26 V ext. source voltage) 1 V ... 5 V (internal resistance, 250 Ω, 0.1%) Configurable via DIP switches < 600 Ω (20 mA) < 20 mV _{rms}
19.2 V AC/DC ... 253 V AC/DC (24 V AC/DC ... 230 V AC/DC (-20 % ... +10 %, 50/60 Hz)) < 80 mA (24 V DC / 20 mA) < 1.6 W (24 V DC / 20 mA) < 0.01 %/K < 600 μs (for 4 mA ... 20 mA step) < 0.05 % (of final value) < 0.1 % (of final value) according to NE 43
300 V _{rms} (Rated insulation voltage (overvoltage category II; degree of pollution 2, safe isolation as per EN 61010-1)) 2.5 kV (50 Hz, 1 min., test voltage)
-20 °C ... 60 °C (Any mounting position) Green LED (supply voltage) Yes as per HART specifications HART PA 66-FR 17.5 / 99 / 114.5 mm 0.2 ... 2.5 mm ² / 0.2 ... 2.5 mm ² / 24 - 14 0.2 ... 1.5 mm ² / 0.2 ... 1.5 mm ² / 24 - 16 Class A product, see page 605
CE-compliant, additionally EN 61326-1 Ex II 3 G Ex nA IIC T4 Gc X UL 508 Listed UL 61010 Listed Class I, Div. 2, Groups A, B, C, D T4 Class I, Zone 2, Group IIC T4 2

Repeater power supply and input signal conditioner for the operation of 2-wire measuring transducers, 4-wire measuring transducers, and mA current sources

- 0/4 to 20 mA input (powered or not powered)
- 0/4 to 20 mA output (active or passive), 0/1 to 5 V, can be selected via DIP switch
- Bidirectional transmission of digital HART communication signals
- Plug-in screw or Push-in connection technology, with integrated sockets for HART communicators
- 250 Ω resistor that can be activated via DIP switches to increase the HART impedance in the case of low-impedance systems
- 3-way electrical isolation
- Wide-range power supply of 19.2 to 253 V AC/DC
- Up to SIL 2 according to IEC 61508
- Installation in Zone 2 permitted

Notes:
Information about the supply and error evaluation module as well as about the DIN rail connectors and marking material can be found from page 174
Test plugs for test sockets can be found on page 176

Ordering data

Description	Type	Order No.	Pcs./ Pkt.
Repeater power supply, with HART® protocol			
Screw connection	MACX MCR-SL-RPSSI-I-UP	2865968	1
Push-in connection	MACX MCR-SL-RPSSI-I-UP-SP	2924210	1

Analog IN / Analog OUT
repeater power supplies

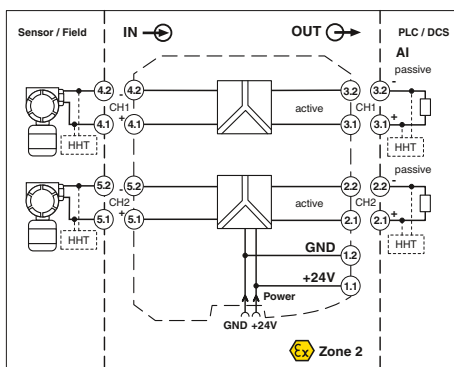
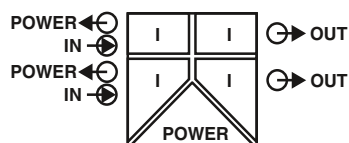

2-channel repeater power supply

Functional Safety
Ex:
Housing width 12.5 mm

Technical data

Input data	per channel
Input signal	4 mA ... 20 mA
Transmitter supply voltage	> 16 V (at 20 mA)
Underload/overload signal range	0 mA ... 24 mA
Output data	per channel
Output signal	4 mA ... 20 mA (active)
Load	≤ 450 Ω (20 mA)
Underload/overload signal range	0 mA ... 24 mA
General data	
Supply voltage range	19.2 V DC ... 30 V DC (24 V DC -20%...+25%)
Current consumption	< 100 mA (24 V / 20 mA)
Power dissipation	< 1.4 W (at 24 V DC / 20 mA)
Temperature coefficient	< 0.01 %/K
Step response (10-90%)	< 1.3 ms (for 4 mA ... 20 mA step)
Transmission error, typical	< 0.05 % (of final value)
Maximum transmission error	< 0.1 % (of final value)
Electrical isolation	
Input/output, power supply	300 V _{rms} (Rated insulation voltage (overvoltage category II; degree of pollution 2, safe isolation as per EN 61010-1)) 2.5 kV (50 Hz, 1 min., test voltage)
Input/output	375 V (Peak value in accordance with EN 60079-11)
Input/power supply	375 V (Peak value in accordance with EN 60079-11)
Output 1/output 2/ power supply	1.5 kV (50 Hz, 1 min., test voltage) -20 °C ... 60 °C (Any mounting position) Green LED (supply voltage) Yes as per HART specifications HART PA 66-FR 12.5 / 99 / 114.5 mm 0.2 ... 1.5 mm ² / 0.2 ... 1.5 mm ² / 24 - 16 0.2 ... 1.5 mm ² / 0.2 ... 1.5 mm ² / 24 - 16 Class A product, see page 605
Conformance/Approvals	
Conformance	CE-compliant, additionally EN 61326
ATEX	II 3 G Ex nA IIC T4 Gc X
UL, USA/Canada	UL 61010 Listed Class I, Div. 2, Groups A, B, C, D T4 Class I, Zone 2, Group IIC T4 2
SIL in accordance with IEC 61508	

Repeater power supply for the operation of 2-wire measuring transducers.

- 2-channel
- Input: 4 to 20 mA (powered)
- Output: 4 to 20 mA (active)
- Bidirectional transmission of digital HART communication signals
- Plug-in screw or Push-in connection technology, with integrated sockets for HART communicators
- Safe 3-way electrical isolation
- Power supply via DIN rail connector possible
- Up to SIL 3 according to IEC 61508
- Installation in Zone 2 permitted

Notes:
Information about the supply and error evaluation module as well as about the DIN rail connectors and marking material can be found from page 174
Test plugs for test sockets can be found on page 176
Information on "Plug and play" connection using system cabling can be found from page 164

Ambient temperature range
Status indication
SMART communication
Signal bandwidth
Protocols supported
Housing material
Dimensions W/H/D
Screw connection solid/stranded/AWG
Push-in connection solid/stranded/AWG
EMC note
Conformance/Approvals
Conformance
ATEX
UL, USA/Canada

SIL in accordance with IEC 61508

Ordering data

Description	Type	Order No.	Pcs./Pkt.	
Repeater power supply, 2-channel	Screw connection	MACX MCR-SL-RPSS-2I-2I	2904089	1
	Push-in connection	MACX MCR-SL-RPSS-2I-2I-SP	2904090	1

Analog IN / Analog OUT
passive isolators

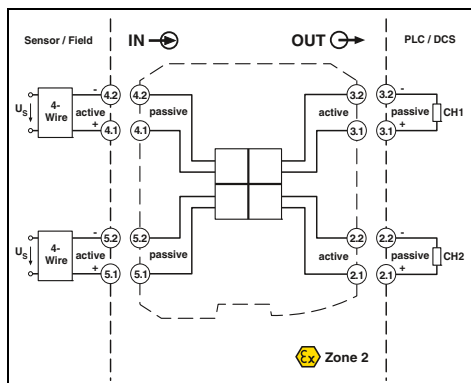
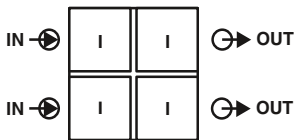

Ex n



Ex: UL US

Housing width 12.5 mm



Passive isolator, single and two-channel

The single or two-channel input loop-powered 2-way isolator with increased isolation voltage and plug-in connection technology is used for the electrical isolation and filtering of analog signals.

The device allows operation on active sensor technology with a supply voltage of 6 to 30 V DC.

The device is powered via the current loop of the sensor. As a result, no additional power supply is required.

Technical data	
Input data	
Max. voltage input signal	< 30.5 V
Input signal	0 mA ... 20 mA / 4 mA ... 20 mA
Input voltage limitation	30.5 V
Voltage dissipation	2.9 V (I = 20 mA)
Response current	approx. 50 µA
Output data	
Max. voltage output signal	27.5 V
Output signal	0 mA ... 20 mA / 4 mA ... 20 mA
Residual ripple	< 10 mV _{rms} (500 Ω load)
Transmission behavior	1:1 to input signal
Load	≤ 1375 Ω (I = 20 mA)
General data	
Supply voltage range	no separate supply voltage necessary
Temperature coefficient	≤ 0.002 %/K (of measured value / 100 Ω load)
Maximum transmission error	≤ 0.1 % (of final value)
Electrical isolation	
Input/output/power supply	300 V _{rms} (Rated insulation voltage (overvoltage category II; degree of pollution 2, safe isolation as per EN 61010-1)) 2.5 kV (50 Hz, 1 min., test voltage)
Ambient temperature range	-40 °C ... 85 °C
Humidity	5 % ... 95 % (non-condensing)
Degree of protection	IP20
Inflammability class in acc. with UL 94	V0
Housing material	PA 66
Dimensions W/H/D	12.5 / 99 / 114.5 mm
Screw connection solid/stranded/AWG	0.2 ... 2.5 mm ² / 0.2 ... 2.5 mm ² / 24 - 14
Push-in connection solid/stranded/AWG	0.2 ... 1.5 mm ² / 0.2 ... 1.5 mm ² / 24 - 16
Conformance/Approvals	
Conformance	CE-compliant, additionally EN 61326-1
ATEX	Ex n II 3 G Ex nA IIC T4 Gc X
UL, USA/Canada	UL 61010 Listed Class I, Div. 2, Groups A, B, C, D T4 Class I, Zone 2, Group IIC T4
SIL in accordance with IEC 61508	3

Ordering data				
Description	Type	Order No.	Pcs./Pkt.	
Passive isolator , single or two-channel	Push-in connection	MACX MCR-SL-I-I-ILP-SP	2905279	1
	Screw connection	MACX MCR-SL-I-I-ILP	2905278	1
	Push-in connection	MACX MCR-SL-2I-2I-ILP-SP	2905281	1
	Screw connection	MACX MCR-SL-2I-2I-ILP	2905280	1

Analog IN / Analog OUT passive isolators

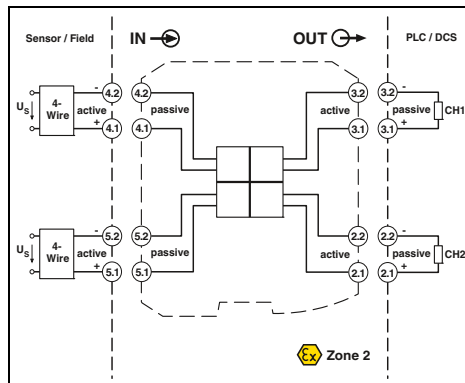
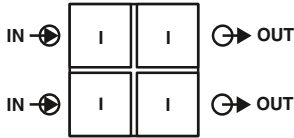

Passive isolator, single and two-channel
5 kV test voltage



EX: us
Housing width 12.5 mm

Technical data

Input data	Max. voltage input signal Input signal Input voltage limitation Voltage dissipation Response current	< 30.5 V 0 mA ... 20 mA / 4 mA ... 20 mA 30.5 V 2.9 V (I = 20 mA) approx. 50 µA
Output data	Max. voltage output signal Output signal Residual ripple Transmission behavior Load	27.5 V 0 mA ... 20 mA / 4 mA ... 20 mA < 10 mV _{rms} (500 Ω load) 1:1 to input signal ≤ 1375 Ω (I = 20 mA)
General data	Supply voltage range	no separate supply voltage necessary
	Temperature coefficient Maximum transmission error Electrical isolation	≤ 0.002 %/K (of measured value / 100 Ω load) ≤ 0.1 % (of final value)
	Input/output/power supply	600 V _{rms} (Rated insulation voltage (overvoltage category II; degree of pollution 2, safe isolation as per EN 61010-1)) 5 kV (50 Hz, 1 min., test voltage)
	Ambient temperature range Humidity Degree of protection Inflammability class in acc. with UL 94 Housing material Dimensions W/H/D Screw connection solid/stranded/AWG Push-in connection solid/stranded/AWG	-40 °C ... 85 °C 5 % ... 95 % (non-condensing) IP20 V0 PA 66 12.5 / 99 / 114.5 mm 0.2 ... 2.5 mm ² / 0.2 ... 2.5 mm ² / 24 - 14 0.2 ... 1.5 mm ² / 0.2 ... 1.5 mm ² / 24 - 16
	Conformance/Approvals	CE-compliant, additionally EN 61326-1 Ex II 3 G Ex nA IIC T4 Gc X UL 61010 Listed Class I, Div. 2, Groups A, B, C, D T4 Class I, Zone 2, Group IIC T4 3
	SIL in accordance with IEC 61508	

Ordering data

Description	Type	Order No.	Pcs./Pkt.
Passive isolator, single or two-channel	Push-in connection	MACX MCR-SL-I-I-HV-ILP-SP	1
	Screw connection	MACX MCR-SL-I-I-HV-ILP	1
	Push-in connection	MACX MCR-SL-2I-2I-HV-ILP-SP	1
	Screw connection	MACX MCR-SL-2I-2I-HV-ILP	1

Analog OUT
Output signal conditioner

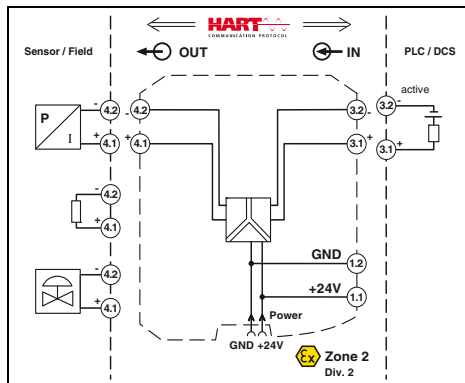
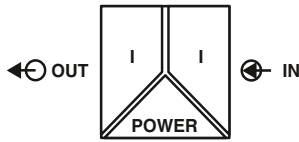

Ex n



Ex n
SIL IEC 61508
FRL DNV GL Functional Safety
Ex: Ex n
Housing width 12.5 mm

Output signal conditioner for controlling I/P transducers, control valves, and displays

- 0/4 to 20 mA input
- 0/4 to 20 mA output
- Bidirectional transmission of digital HART communication signals
- Plug-in screw or Push-in connection technology, with integrated sockets for HART communicators
- Line fault detection (LF)
- 3-way electrical isolation
- Power supply via DIN rail connector possible
- Up to SIL 2 according to IEC 61508
- Installation in Zone 2 permitted

Notes:
Information about the supply and error evaluation module as well as about the DIN rail connectors and marking material can be found from page 174
Test plugs for test sockets can be found on page 176
Information on "Plug and play" connection using system cabling can be found from page 164

Input data
Input signal
Input voltage
Input impedance in the event of a cable break at the output
Output data
Output signal
Load
Output ripple
General data
Supply voltage range
Current consumption
Power dissipation
Temperature coefficient
Step response (10-90%)
Maximum transmission error
Electrical isolation
Input/output/power supply
Ambient temperature range
Humidity
SMART communication
Signal bandwidth
Protocols supported
Inflammability class in acc. with UL 94
Housing material
Dimensions W/H/D
Screw connection solid/stranded/AWG
Push-in connection solid/stranded/AWG
EMC note
Conformance/Approvals
Conformance
ATEX
UL, USA/Canada
SIL in accordance with IEC 61508

Technical data		
0 mA ... 20 mA / 4 mA ... 20 mA	5.4 V (at 20 mA)	> 100 kΩ (if there is a line fault)
0 mA ... 20 mA / 4 mA ... 20 mA	< 800 Ω (20 mA)	< 20 mV _{rms}
19.2 V DC ... 30 V DC (24 V DC -20%...+25%)	< 46 mA (24 V DC / 20 mA)	< 1.1 W (24 V DC / 20 mA)
< 0.01 %/K	< 140 μs (for 4 mA ... 20 mA step)	< 0.1 % (of final value)
1.5 kV (50 Hz, 1 min., test voltage)	300 V _{rms} (Rated insulation voltage (overvoltage category II, degree of pollution 2))	-20 °C ... 60 °C (Any mounting position)
Yes	as per HART specifications	HART
Yes	as per HART specifications	V0
12.5 / 99 / 114.5 mm	0.2 ... 2.5 mm ² / 0.2 ... 2.5 mm ² / 24 - 14	0.2 ... 1.5 mm ² / 0.2 ... 1.5 mm ² / 24 - 16
Class A product, see page 605	CE-compliant, additionally EN 61326-1	Ex II 3 G Ex nA IIC T4 Gc X
	UL 508 Listed	UL 61010 Listed
	Class I, Div. 2, Groups A, B, C, D T4	Class I, Zone 2, Group IIC T4
	2	

Ordering data			
Description	Type	Order No.	Pcs./ Pkt.
Output signal conditioner	MACX MCR-SL-IDSI-I	2865971	1
	MACX MCR-SL-IDSI-I-SP	2924223	1

Temperature
Temperature transducer

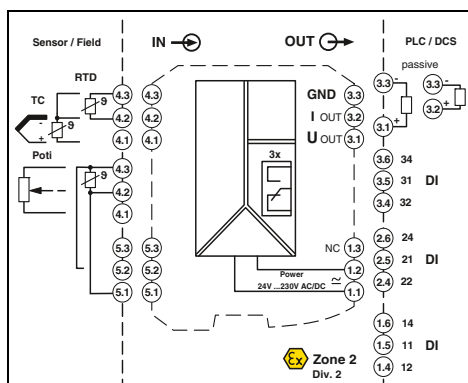
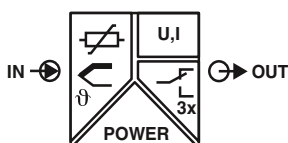

Universal, with three limit value relays,
wide-range power supply

Functional Safety

Ex: Ex n

Housing width 35 mm

Technical data

Input data

Resistance thermometers
Thermocouple sensors

Resistor
Potentiometer
Voltage

Output data

Output signal
Maximum output signal
Load R_B
Behavior in the event of a sensor error

Switching output

Contact type
Contact material
Max. switching voltage
Maximum switching current

General data

Supply voltage range
Power consumption
Temperature coefficient
Maximum transmission error
Electrical isolation

Input/output/power supply

Input/output
Input/power supply
Input/switching output

Ambient temperature range
Humidity
Inflammability class in acc. with UL 94
Housing material
Dimensions W/H/D
Screw connection solid/stranded/AWG
Push-in connection solid/stranded/AWG
EMC note

Conformance/Approvals

Conformance
ATEX
IECEX
UL, USA/Canada

SIL in accordance with IEC 61508

Pt, Ni, Cu sensors: 2, 3, 4-wire
B, E, J, K, N, R, S, T, L, U, CA, DA, A1G, A2G, A3G, MG, LG

0 Ω ... 50 k Ω
0 Ω ... 50 k Ω
-1000 mV ... 1000 mV

U output
0 mA ... 20 mA \pm 10 V (in the case of SIL; further free configuration without SIL)

I output
 \pm 11 V
 \geq 10 k Ω
 \leq 600 Ω (at 20 mA)
according to NE 43 or freely configurable

Relay output
3 PDTs
AgSnO₂, hard gold-plated
250 V AC (250 V DC)
2 A (250 V AC) / 2 A (28 V DC)

24 V ... 230 V AC/DC (-20 %/+10 %, 50/60 Hz)
< 2.4 W
0.01 %/K
0.1 % (e.g. for Pt 100, 300 K span, 4 ... 20 mA)

300 V_{rms} (Rated insulation voltage (overvoltage category II; degree of pollution 2, safe isolation as per EN 61010-1))
2.5 kV (50 Hz, 1 min., test voltage)

375 V (Peak value in accordance with EN 60079-11)
375 V (Peak value in accordance with EN 60079-11)
375 V (Peak value in accordance with EN 60079-11)

-20 °C ... 65 °C
typ. 5 % ... 95 % (non-condensing)
V0
PA 66-FR
35 / 99 / 114.5 mm
0.2 ... 2.5 mm² / 0.2 ... 2.5 mm² / 24 - 14
0.2 ... 1.5 mm² / 0.2 ... 1.5 mm² / 24 - 16
Class A product, see page 605

CE-compliant
Ex II 3 G Ex nA nC ic IIC T4 Gc X
Ex nA nC ic IIC T4 Gc X
UL 508 Listed
Class I, Div. 2, Groups A, B, C, D T6
Class I, Zone 2, Group IIC T6
2

Ordering data

Type	Order No.	Pcs./Pkt.
MACX MCR-T-UIREL-UP	2811378	1
MACX MCR-T-UIREL-UP-SP	2811828	1

Accessories

IFS-USB-PROG-ADAPTER	2811271	1
MACX MCR-CJC	2924993	1

Universal temperature transducer with
freely configurable properties

- Input for resistance thermometers, thermocouples, resistance-type sensors, potentiometers, and mV sources
- Measure differential temperatures
- Freely programmable input and output
- Option of inverse output signal ranges
- Three limit value relays, can be used in combination as a safe limit value relay
- Configuration via software (FDT/DTM) or IFS-OP-UNIT operator interface and display unit
- Programming during operation and also voltage-free using IFS-USB-PROG-ADAPTER programming adapter
- Plug-in screw or Push-in connection technology
- Cold junction compensation with separate connector
- Wide-range power supply of 19.2 to 253 V AC/DC
- Status indicator for supply voltage, cable, sensor, and module errors
- Up to SIL 2 according to IEC 61508
- Installation in Zone 2 permitted

Notes:

The configuration software can be downloaded from the Internet (phoenixcontact.net/products).

Information on the IFS-OP-UNIT operating and display unit and the associated IFS-OP-CRADLE DIN rail cradle can be found on page 171

For information on the programming adapter, refer to page 172

Description	
Temperature transducer	
Standard configuration	Screw connection
Standard configuration	Push-in connection
Programming adapter for configuring modules with S-PORT interface	
Cold junction compensation connector for thermocouples	

Temperature
Temperature transducer

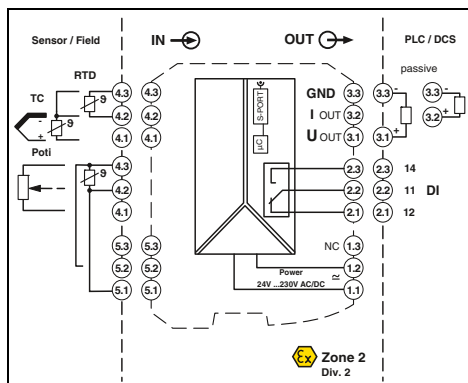
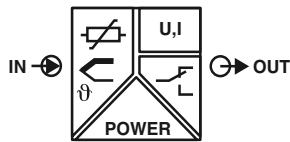

Universal, with switching output, wide-range power supply

Functional Safety

Ex: Ex n

Housing width 17.5 mm

Universal temperature transducer with freely configurable properties

- Input for resistance thermometers, thermocouples, resistance-type sensors, potentiometers, and mV sources
- Measure differential temperatures
- Freely programmable input and output
- Option of inverse output signal ranges
- Relay switching output
- Configuration via software (FDT/DTM) or IFS-OP-UNIT operator interface and display unit
- Programming during operation and also voltage-free using IFS-USB-PROG-ADAPTER programming adapter
- Plug-in screw or Push-in connection technology
- Cold junction compensation with separate connector
- Wide-range power supply of 19.2 to 253 V AC/DC
- Status indicator for supply voltage, cable, sensor, and module errors
- Up to SIL 2 according to IEC 61508
- Installation in Zone 2 permitted

Input data

Resistance thermometers
Thermocouple sensors

Resistor
Potentiometer
Voltage

Output data

Output signal

Maximum output signal
Load R_B

Behavior in the event of a sensor error

Switching output

Contact type
Contact material
Max. switching voltage
Maximum switching current

General data

Supply voltage range
Power consumption
Temperature coefficient
Transmission error, total
Electrical isolation

Input/output/power supply

Input/output
Input/power supply
Input/switching output

Ambient temperature range
Humidity
Inflammability class in acc. with UL 94
Housing material
Dimensions W/H/D
Screw connection solid/stranded/AWG
Push-in connection solid/stranded/AWG
EMC note

Conformance/Approvals

Conformance
ATEX
IECEX
SIL in accordance with IEC 61508

Technical data

Pt, Ni, Cu sensors: 2, 3, 4-wire
B, E, J, K, N, R, S, T, L, U, CA, DA, A1G, A2G, A3G, MG, LG

0 Ω ... 50 kΩ
0 Ω ... 50 kΩ
-1000 mV ... 1000 mV

U output I output
0 mA ... 20 mA ±10 V (in the case of SIL; further free configuration without SIL)

± 11 V 22 mA
≥ 10 kΩ ≤ 600 Ω (20 mA)
according to NE 43 or freely configurable

Relay output

1 PDT
AgSnO₂, hard gold-plated
30 V AC (30 V DC)
0.5 A (30 V AC) / 1 A (30 V DC)

24 V ... 230 V AC/DC (-20 %/+10 %, 50/60 Hz)
< 1.5 W
0.01 %/K
< 0.1 % (e.g., for Pt 100, 300 K span, 4 ... 20 mA)

300 V_{rms} (Rated insulation voltage (overvoltage category II; degree of pollution 2, safe isolation as per EN 61010-1))
2.5 kV (50 Hz, 1 min., test voltage)

375 V (Peak value in accordance with EN 60079-11)

375 V (Peak value in accordance with EN 60079-11)

375 V (Peak value in accordance with EN 60079-11)

-20 °C ... 65 °C

typ. 5 % ... 95 % (non-condensing)

V0

PA 66-FR

17.5 / 99 / 114.5 mm

0.2 ... 2.5 mm² / 0.2 ... 2.5 mm² / 24 - 14

0.2 ... 1.5 mm² / 0.2 ... 1.5 mm² / 24 - 16

Class A product, see page 605

CE-compliant

Ex II 3 G Ex nA nC ic IIC T4 Gc X

Ex nA nC ic IIC T4 Gc X

2

Notes:

To order a product with an order configuration, enter the required configuration by referring to the adjacent order key.

The configuration software can be downloaded from the Internet (phoenixcontact.net/products).

Information on the IFS-OP-UNIT operating and display unit and the associated IFS-OP-CRADLE DIN rail cradle can be found on page 171

For information on the programming adapter, refer to page 172

Description

Temperature transducer

Standard configuration	Screw connection
Standard configuration	Push-in connection
Order configuration	Screw connection
Order configuration	Push-in connection

Programming adapter for configuring modules with S-PORT interface

Cold junction compensation connector for thermocouples

Ordering data

Type	Order No.	Pcs./Pkt.
MACX MCR-T-UI-UP	2811394	1
MACX MCR-T-UI-UP-SP	2811860	1
MACX MCR-T-UI-UP-C	2811873	1
MACX MCR-T-UI-UP-SP-C	2811970	1

Accessories

IFS-USB-PROG-ADAPTER	2811271	1
MACX MCR-CJC	2924993	1

Signal conditioners with SIL functional safety – MACX Analog

Order key for MACX MCR-T-UI-UP(-SP)-C temperature transducers (standard configuration entered as an example)

Order No.	Safety Integrity Level (SIL)	Sensor type	Connection technology	Cold junction compensation	Measuring range:		Measuring unit	Output range	Factory calibration certificate = FCC
					Start	End			
2811873	ON	PT100	4	0	-50	150	C	OUT02	NONE
2811873 ≙ MACX MCR-T-UI-UP-C	ON ≙ Active NONE ≙ Not active	See below	2 ≙ 2-conductor 3 ≙ 3-conductor 4 ≙ 4-conductor	0 ≙ Off, e.g., with RTD, R, potentiometer, mV 1 ≙ On, e.g., with TC	See below	See below	C ≙ °C F ≙ °F Ω ≙ Ω P ≙ % V ≙ mV	OUT15 ≙ 0 ... 5 mA OUT16 ≙ 0 ... 10 mA OUT01 ≙ 0 ... 20 mA OUT15 ≙ 0 ... 5 mA OUT25 ≙ 1 ... 5 mA OUT26 ≙ 2 ... 10 mA OUT02 ≙ 4 ... 20 mA OUT05 ≙ 0 ... 5 V OUT03 ≙ 0 ... 10 V OUT06 ≙ 1 ... 5 V OUT04 ≙ 2 ... 10 V OUT13 ≙ -5 ... +5 V OUT14 ≙ -10 ... +10 V Others can be freely configured in the software	NONE ≙ Without FCC Yes ≙ With FCC (a fee is charged) YESPLUS ≙ FCC with 5 measuring points (a fee is charged)
2811970 ≙ MACX MCR-T-UI-UP-SP-C	ON only with output range = OUT02								
Resistance thermometers (RTD) Others can be selected or freely configured in the software.									
		PT100 ≙ Pt 100 according to IEC 751			-200	850	°C	20 K	
		PT200 ≙ Pt 200 according to IEC 751			-200	850	°C	20 K	
		PT500 ≙ Pt 500 according to IEC 751			-200	850	°C	20 K	
		PT1000 ≙ Pt 1000 according to IEC 751			-200	850	°C	20 K	
		PT100S ≙ Pt 100 according to Sama RC21-4-1966			-200	850	°C	20 K	
		PT1000S ≙ Pt 1000 according to Sama RC21-4-1966			-200	850	°C	20 K	
		PT100G ≙ Pt 100 according to GOST 6651-2009 (α = 0.00385)			-200	850	°C	20 K	
		PT1000G ≙ Pt 1000 according to GOST 6651-2009 (α = 0.00385)			-200	850	°C	20 K	
		PT100J ≙ Pt 100 according to JIS C1604/1997			-200	850	°C	20 K	
		PT1000J ≙ Pt 1000 according to JIS C1604/1997			-200	850	°C	20 K	
		NI100 ≙ Ni 100 according to DIN 43760/DIN IEC 60751			-60	250	°C	20 K	
		NI1000 ≙ Ni 1000 according to DIN 43760/DIN IEC 60751			-60	250	°C	20 K	
		NI100S ≙ Ni 100 according to Sama RC21-4-1966			-60	180	°C	20 K	
		NI1000S ≙ Ni 1000 according to Sama RC21-4-1966			-60	180	°C	20 K	
		NI1000L ≙ Ni 1000 (Landis & Gyr)			-50	160	°C	20 K	
		CU10 ≙ Cu 10 according to Sama RC21-4-1966			-70	500	°C	100 K	
		CU50 ≙ Cu50 according to GOST 6651-2009 (α = 0.00428)			-50	200	°C	100 K	
		CU100 ≙ Cu100 according to GOST 6651-2009 (α = 0.00428)			-50	200	°C	100 K	
		CU53 ≙ Cu53 according to GOST 6651-2009 (α = 0.00426)			-50	180	°C	100 K	
		KTY81 ≙ KTY81-110 (Philips)			-55	150	°C	20 K	
		KTY84 ≙ KTY84-130 (Philips)			-40	300	°C	20 K	
Thermocouples (TC) Others can be selected in the software.									
		B ≙ according to IEC 584-1 (Pt30Rh-Pt6Rh)			500	1820	°C	50 K	
		E ≙ according to IEC 584-1 (NiCr-CuNi)			-230	1000	°C	50 K	
		J ≙ according to IEC 584-1 (Fe-CuNi)			-210	1200	°C	50 K	
		K ≙ according to IEC 584-1 (NiCr-Ni)			-250	1372	°C	50 K	
		N ≙ according to IEC 584-1 (NiCrSi-NiSi)			-250	1300	°C	50 K	
		R ≙ according to IEC 584-1 (Pt13Rh-Pt)			-50	1768	°C	50 K	
		S ≙ according to IEC 584-1 (Pt10Rh-Pt)			-50	1768	°C	50 K	
		T ≙ according to IEC 584-1 (Cu-CuNi)			-200	400	°C	50 K	
		L ≙ according to DIN 43760 (Fe-CuNi)			-200	900	°C	50 K	
		U ≙ according to DIN 43760 (Cu-CuNi)			-200	600	°C	50 K	
		CA ≙ C ASTM JE988 (2002)			0	2315	°C	50 K	
		DA ≙ D ASTM JE988 (2002)			0	2315	°C	50 K	
		A1G ≙ A-1 GOST 8.585-2001			0	2500	°C	50 K	
		A2G ≙ A-2 GOST 8.585-2001			0	1800	°C	50 K	
		A3G ≙ A-3 GOST 8.585-2001			0	1800	°C	50 K	
		MG ≙ M GOST 8.585-2001			-200	100	°C	50 K	
		LG ≙ L GOST 8.585-2001			-200	800	°C	50 K	
Remote resistance-type sensors (R) (2-, 3-, 4-conductor) Others can be selected in the software.									
		RES03 ≙ Resistance 0 ... 150 Ω			0	150	Ω		
		RES05 ≙ Resistance 0 ... 600 Ω			0	600	Ω		
		RES06 ≙ Resistance 0 ... 1200 Ω			0	1200	Ω		
		RES09 ≙ Resistance 0 ... 6250 Ω			0	6250	Ω		
		RES10 ≙ Resistance 0 ... 12,500 Ω			0	12,500	Ω		
		RES12 ≙ Resistance 0 ... 50,000 Ω			0	50,000	Ω		
Potentiometers (3-conductor) Others can be selected in the software.									
		POT03 ≙ Potentiometer 0 ... 150 Ω			0	100	%		
		POT05 ≙ Potentiometer 0 ... 600 Ω			0	100	%		
		POT06 ≙ Potentiometer 0 ... 1200 Ω			0	100	%		
		POT09 ≙ Potentiometer 0 ... 6250 Ω			0	100	%		
		POT10 ≙ Potentiometer 0 ... 12,500 Ω			0	100	%		
		POT12 ≙ Potentiometer 0 ... 50,000 Ω			0	100	%		
Voltage signals (mV) Others can be selected in the software.									
		V04 ≙ Voltage (mV)			-1000	+1000	mV		

Smallest measuring range span

Other setting options can be configured with the IFS-CONF software:

- Freely configurable user characteristic curve with 30 interpolation points
- Output behavior in the event of a short circuit, sensor break or overrange/underrange can be freely configured or set according to NE43 (standard configuration: NE43 upscale)
- Filter setting (standard configuration: 1)
- Restart after failsafe (standard configuration: ON)
- Switching behavior: switching output (limit values, times, etc.) (standard configuration: OFF)

Temperature conversion guide for °C to °F: $T [°F] = \frac{9}{5} T [°C] + 32$

Temperature
Temperature transducer

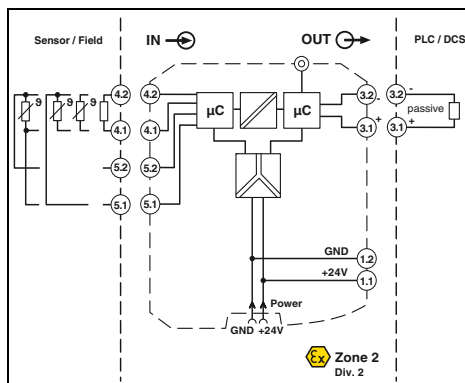
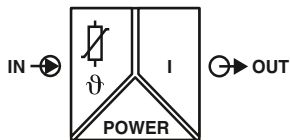

Ex n



For resistance thermometers and resistance-type sensors

DNV GL
Ex:
Housing width 12.5 mm

Programmable temperature transducer for operating resistance thermometers and resistance-type sensors. The measured values are converted into a linear 0 to 20 mA or 4 to 20 mA signal.

- Input for resistance thermometers and resistance-type sensors
- 0 to 20 mA or 4 to 20 mA output
- Configuration via software (FDT/DTM): Sensor type, connection method, measuring range, measuring unit, filter, alarm signal, and output range
- Programming during operation and also voltage-free using IFS-USB-PROG-ADAPTER programming adapter
- Status indicator for supply voltage, cable, sensor, and module errors
- 3-way electrical isolation
- Power supply via DIN rail connector possible
- Installation in Zone 2 permitted

Input data

Resistance thermometers
Resistor
Cable resistance
Sensor input current
Measuring range span

Output data

Output signal
Load
Behavior in the event of a sensor error
Output ripple

General data

Supply voltage range
Current consumption
Power dissipation
Temperature coefficient
Step response (0–99%)

Transmission error, total
ZERO / SPAN adjustment
Electrical isolation

Input/output/power supply

Input/output
Input/power supply

Ambient temperature range
Humidity
Inflammability class in acc. with UL 94
Housing material
Dimensions W/H/D
Screw connection solid/stranded/AWG
Push-in connection solid/stranded/AWG
EMC note

Conformance/Approvals

Conformance
ATEX
UL, USA/Canada

Technical data

Pt, Ni, Cu sensors: 2, 3, 4-wire
0 Ω ... 2000 Ω
50 Ω per line
200 µA ... 1 mA
> 50 K
0 mA ... 20 mA / 4 mA ... 20 mA
≤ 500 Ω
As per NE 43 or can be freely defined
< 50 µA_{PP}
19.2 V DC ... 30 V DC (24 V DC -20%...+25%)
< 40 mA (24 V DC)
< 1 W
0.01 %/K
typ. 700 ms
≤ 1100 ms
0.1 % x 1000 [K]/measuring span
± 5 % / ± 5 %

2.5 kV (50 Hz, 1 min., test voltage)
300 V_{rms} (Rated insulation voltage (overvoltage category II; degree of pollution 2, safe isolation as per EN 61010-1))

375 V (Peak value in accordance with EN 60079-11)
375 V (Peak value in accordance with EN 60079-11)
-20 °C ... 60 °C (Any mounting position)
5 % ... 95 % (non-condensing)
V0
PA 66-FR
12.5 / 99 / 114.5 mm
0.2 ... 2.5 mm² / 0.2 ... 2.5 mm² / 24 - 14
0.2 ... 1.5 mm² / 0.2 ... 1.5 mm² / 24 - 16
Class A product, see page 605

CE-compliant, additionally EN 61326-1
Ex II 3G Ex nA ic IIC T4 Gc X
UL 508 Listed
UL 61010 Listed
Class I, Div. 2, Groups A, B, C, D T4
Class I, Zone 2, Group IIC T4

Ordering data

Type	Order No.	Pcs./ Pkt.
MACX MCR-SL-RTD-I	2865065	1
MACX MCR-SL-RTD-I-SP	2924317	1
MACX MCR-SL-RTD-I-NC	2865078	1
MACX MCR-SL-RTD-I-SP-NC	2924320	1

Accessories

IFS-USB-PROG-ADAPTER	2811271	1
----------------------	---------	---

Notes:

- To order a product with an order configuration, please enter the desired configuration by referring to the order key provided online (phoenixcontact.net/products).
- The configuration software can be downloaded from the Internet (phoenixcontact.net/products).
- Information about the supply and error evaluation module as well as about the DIN rail connectors and marking material can be found from page 174
- For information on the programming adapter, refer to page 172
- Test plugs for test sockets can be found on page 176
- Information on "Plug and play" connection using system cabling can be found from page 164

Description

Temperature transducer	
Order configuration	Screw connection
Order configuration	Push-in connection
Standard configuration	Screw connection
Standard configuration	Push-in connection

Programming adapter for configuring modules with S-PORT interface

Temperature
Temperature transducer

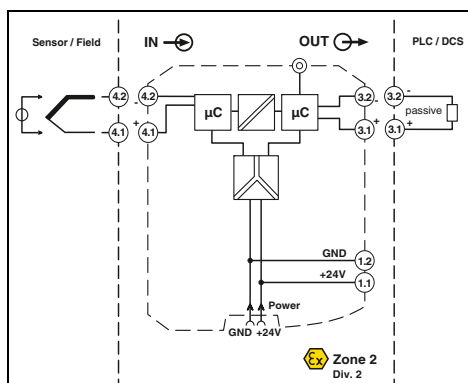
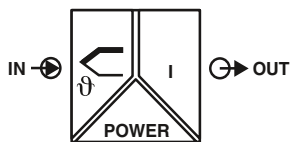

Ex n



For thermocouples and mV sources

DNV GL

Ex:

Housing width 12.5 mm

Programmable temperature transducer for operating thermocouples and mV sources. The measured values are converted into a linear 0 to 20 mA or 4 to 20 mA signal.

- Input for thermocouples and mV sources
- 0 to 20 mA or 4 to 20 mA output
- Configuration via software (FDT/DTM): Sensor type, connection method, measuring range, measuring unit, filter, alarm signal, and output range
- Programming during operation and also voltage-free using IFS-USB-PROG-ADAPTER programming adapter
- Status indicator for supply voltage, cable, sensor, and module errors
- 3-way electrical isolation
- Power supply via DIN rail connector possible
- Installation in Zone 2 permitted

Input data

Thermocouple sensors

Voltage

Measuring range span

Output data

Output signal

Load

Behavior in the event of a sensor error

Output ripple

General data

Supply voltage range

Current consumption

Power dissipation

Temperature coefficient

Step response (0–99%)

Transmission error, total

Cold junction errors

ZERO / SPAN adjustment

Electrical isolation

Input/output/power supply

Input/output

Input/power supply

Ambient temperature range

Humidity

Inflammability class in acc. with UL 94

Housing material

Dimensions W/H/D

Screw connection solid/stranded/AWG

EMC note

Conformance/Approvals

Conformance

ATEX

UL, USA/Canada

Technical data

E, J, K, N as per IEC / EN 60584, L as per DIN 43760

-20 mV ... 70 mV

Min. 50 K for thermocouples, 3 mV for mV sources

0 mA ... 20 mA / 4 mA ... 20 mA

max. 500 Ω

As per NE 43 or can be freely defined

< 50 µA_{pp}

19.2 V DC ... 30 V DC (24 V DC -20%...+25%)

< 40 mA (24 V DC)

< 1 W

0.01 %/K

typ. 700 ms

≤ 1100 ms

0.1 % x 600 [K]/measuring span; 0.1 % > 600 [K]

± 1 K

± 5 % / ± 5 %

300 V_{rms} (Rated insulation voltage (overvoltage category II; degree of pollution 2, safe isolation as per EN 61010-1))
2.5 kV (50 Hz, 1 min., test voltage)

375 V (Peak value in accordance with EN 60079-11)

375 V (Peak value in accordance with EN 60079-11)

-20 °C ... 60 °C (Any mounting position)

5 % ... 95 % (non-condensing)

V0

PA 66-FR

12.5 / 99 / 114.5 mm

0.2 ... 2.5 mm² / 0.2 ... 2.5 mm² / 24 - 14

Class A product, see page 605

CE-compliant, additionally EN 61326-1

Ex II 3G Ex nA ic IIC T4 Gc X

UL 508 Listed

UL 61010 Listed

Class I, Div. 2, Groups A, B, C, D T4

Class I, Zone 2, Group IIC T4

Ordering data

Description

Temperature transducer

Order configuration

Screw connection

Standard configuration

Screw connection

Programming adapter for configuring modules with S-PORT interface

Type

Order No.

Pcs./Pkt.

MACX MCR-SL-TC-I

2924333

1

MACX MCR-SL-TC-I-NC

2924346

1

Accessories

IFS-USB-PROG-ADAPTER

2811271

1

Digital IN
NAMUR signal conditioners

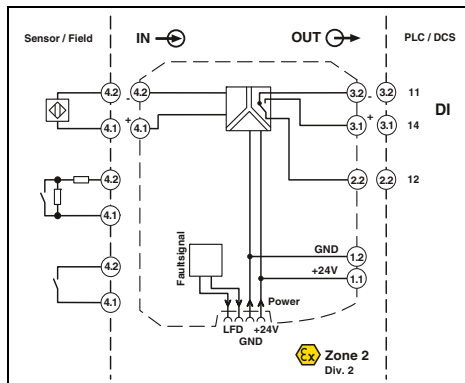
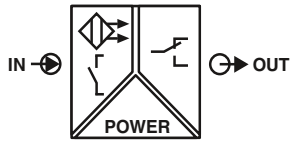

Ex n



IEC 61508



Signal output: PDT relay

NAMUR signal conditioner for operating proximity sensors and mechanical contacts

- Input for NAMUR proximity sensors (EN 60947-5-6), floating contacts or contacts with resistance circuit
- Relay signal output (PDT)
- Reversible direction of action (operating current or closed-circuit current behavior)
- Line fault detection (LFD) can be activated and deactivated, error indicated by red flashing LED and de-excitation of the output relay
- Power supply and error indication possible via the DIN rail connector
- LED displays for indicating supply voltage, circuit state, and malfunctions to NAMUR NE 44
- 3-way electrical isolation
- Up to SIL 2 according to IEC 61508
- Installation in Zone 2 permitted

Notes:
Information about the supply and error evaluation module as well as about the DIN rail connectors and marking material can be found from page 174
Information about resistance circuits is given on page 176
Information on "Plug and play" connection using system cabling can be found from page 164

Input data
Input signal

No-load voltage
Switching points
Switching hysteresis
Line fault detection

Switching output

Contact type
Contact material
Max. switching voltage
Maximum switching capacity
Recommended minimum load
Mechanical service life
Switching behavior
Maximum switching frequency

General data

Supply voltage range
Current consumption
Power dissipation
Electrical isolation

Input/output
Input/output/supply, DIN rail connector

Output/input, supply, DIN rail connector

Input/supply, DIN rail connector

Ambient temperature range
Humidity
Inflammability class in acc. with UL 94
Housing material
Dimensions W/H/D
Screw connection solid/stranded/AWG
Push-in connection solid/stranded/AWG
EMC note

Conformance/Approvals

Conformance
ATEX
UL, USA/Canada

SIL in accordance with IEC 61508

Description
NAMUR signal conditioner
Screw connection
Push-in connection

IEC 61508
Ex n
SIL
IEC 61508
FAC DNV GL Functional Safety
Ex: Ex
Housing width 12.5 mm

Technical data

NAMUR proximity sensors (EN 60947-5-6)
open circuit switch contacts
Switch contacts with resistance circuit
~ 8 V DC
> 2.1 mA (conductive) / < 1.2 mA (blocking)
< 0.2 mA
Break 0.05 mA < I_{IN} < 0.35 mA
Short circuit 100 Ω < R_{Sensor} < 360 Ω

Relay output

1 PDT
AgSnO₂, hard gold-plated
250 V AC (2 A) / 120 V DC (0.2 A) / 30 V DC (2 A)
500 VA
5 V / 10 mA
10⁷ cycles
Can be inverted via slide switch
≤ 20 Hz (without load)

19.2 V DC ... 30 V DC (24 V DC -20%...+25%)
21 mA (24 V DC)
< 650 mW

375 V (Peak value in accordance with EN 60079-11)
300 V_{rms} (Rated insulation voltage (overvoltage category II); degree of pollution 2, safe isolation as per EN 61010-1)
2.5 kV (50 Hz, 1 min., test voltage)

300 V_{rms} (Rated insulation voltage (overvoltage category III); degree of pollution 2, safe isolation as per EN 61010-1)
2.5 kV (50 Hz, 1 min., test voltage)

375 V (Peak value in accordance with EN 60079-11)
-20 °C ... 60 °C (Any mounting position)
10 % ... 95 % (non-condensing)

V0
PA 66-FR
12.5 / 99 / 114.5 mm
0.2 ... 2.5 mm² / 0.2 ... 2.5 mm² / 24 - 14
0.2 ... 1.5 mm² / 0.2 ... 1.5 mm² / 24 - 16
Class A product, see page 605

CE-compliant, additionally EN 61326-1
Ex II 3 G Ex nA nC IIC T4 Gc X
UL 508 Listed
UL 61010 Listed
Class I, Div. 2, Groups A, B, C, D T4
Class I, Zone 2, Group IIC T4

2

Ordering data

Type	Order No.	Pcs./ Pkt.
MACX MCR-SL-NAM-R	2865997	1
MACX MCR-SL-NAM-R-SP	2924252	1

Digital IN
NAMUR signal conditioners

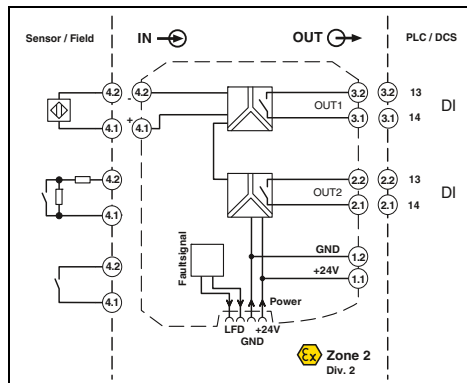
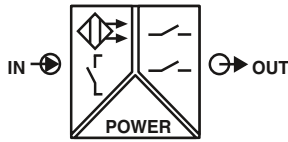

2 signal outputs: N/O contact relay

Ⓢ DNV GL Functional Safety

Ex: Ⓢ Ex

Housing width 12.5 mm

NAMUR signal conditioner for operating proximity sensors and mechanical contacts

- Input for NAMUR proximity sensors (EN 60947-5-6), floating contacts or contacts with resistance circuit
- 2 relay signal outputs (N/O contact), output 2 can also be used as an error signal output
- Reversible direction of action (operating current or closed-circuit current behavior)
- Line fault detection (LFD) can be activated and deactivated, error indicated by red flashing LED and de-excitation of the output relay
- Power supply and error indication possible via the DIN rail connector
- LED displays for indicating supply voltage, circuit state, and malfunctions to NAMUR NE 44
- 4-way electrical isolation
- Up to SIL 2 according to IEC 61508
- Installation in Zone 2 permitted

Input data

Input signal

- No-load voltage
- Switching points
- Switching hysteresis
- Line fault detection

Switching output

- Contact type
- Contact material
- Max. switching voltage
- Maximum switching capacity
- Recommended minimum load
- Mechanical service life
- Switching behavior
- Maximum switching frequency

General data

- Supply voltage range
- Current consumption
- Power dissipation
- Electrical isolation

Input/output

Output 1/output 2/input, power supply, DIN rail connector

- Ambient temperature range
- Humidity
- Inflammability class in acc. with UL 94
- Housing material
- Dimensions W/H/D
- Screw connection solid/stranded/AWG
- Push-in connection solid/stranded/AWG
- EMC note

Conformance/Approvals

- Conformance
- ATEX
- UL, USA/Canada

SIL in accordance with IEC 61508

Technical data

NAMUR proximity sensors (EN 60947-5-6)

- open circuit switch contacts
- Switch contacts with resistance circuit
- ~ 8 V DC
- > 2.1 mA (conductive) / < 1.2 mA (blocking)
- < 0.2 mA
- Break 0.05 mA < IIN < 0.35 mA
- Short circuit 100 Ω < RSensor < 360 Ω

Relay output

- 2 N/O contacts
- AgSnO₂, hard gold-plated
- 250 V AC (2 A) / 120 V DC (0.2 A) / 30 V DC (2 A)
- 500 VA
- 5 V / 10 mA
- 10⁷ cycles
- Can be inverted via slide switch
- ≤ 20 Hz (without load)

19.2 V DC ... 30 V DC (24 V DC -20%...+25%)

30 mA (24 V DC)

< 950 mW

375 V (Peak value in accordance with EN 60079-11)

300 V_{rms} (Rated insulation voltage (overvoltage category III); degree of pollution 2, safe isolation as per EN 61010-1))

-20 °C ... 60 °C (Any mounting position)

10 % ... 95 % (non-condensing)

V0

PA 66-FR

12.5 / 99 / 114.5 mm

0.2 ... 2.5 mm² / 0.2 ... 2.5 mm² / 24 - 14

0.2 ... 1.5 mm² / 0.2 ... 1.5 mm² / 24 - 16

Class A product, see page 605

CE-compliant, additionally EN 61326-1

Ⓢ II 3 G Ex nA nC IIC T4 Gc X

UL 508 Listed

UL 61010 Listed

Class I, Div. 2, Groups A, B, C, D T4

Class I, Zone 2, Group IIC T4

2

Ordering data

Description

NAMUR signal conditioner

Screw connection

Push-in connection

Type

MACX MCR-SL-NAM-2RO

MACX MCR-SL-NAM-2RO-SP

Order No.

2865010

2924265

Pcs./ Pkt.

1

1

Notes:

Information about the supply and error evaluation module as well as about the DIN rail connectors and marking material can be found from page 174

Information about resistance circuits is given on page 176

Information on "Plug and play" connection using system cabling can be found from page 164

Digital IN
NAMUR signal conditioners

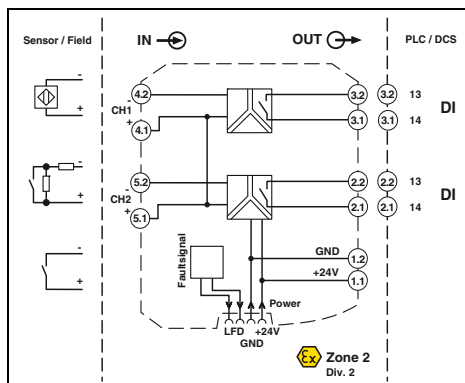
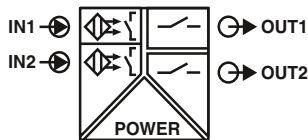

Ex n



2-channel, signal output: N/O contact relay

DNV GL Functional Safety

Ex: Ex

Housing width 12.5 mm

NAMUR signal conditioner for intrinsically safe operation of proximity sensors and mechanical contacts installed in Ex areas.

- 2-channel
- Input for NAMUR proximity sensors (EN 60947-5-6), floating contacts or contacts with resistance circuit
- Relay signal output (N/O contact)
- Reversible direction of action (operating current or closed-circuit current behavior)
- Line fault detection (LFD) can be activated and deactivated, error indicated by red flashing LED and de-excitation of the output relay
- Power supply and error indication possible via the DIN rail connector
- LED displays for indicating supply voltage, circuit state, and malfunctions to NAMUR NE 44
- 3-way electrical isolation
- Up to SIL 2 according to IEC 61508
- Installation in Zone 2 permitted

Notes:
Information about the supply and error evaluation module as well as about the DIN rail connectors and marking material can be found from page 174
Information about resistance circuits is given on page 176
Information on "Plug and play" connection using system cabling can be found from page 164

Input data
Input signal

No-load voltage
Switching points
Switching hysteresis
Line fault detection

Switching output

Contact type
Contact material
Max. switching voltage
Maximum switching capacity
Recommended minimum load
Mechanical service life
Switching behavior
Maximum switching frequency

General data

Supply voltage range
Current consumption
Power dissipation
Electrical isolation

Input/output
Input/supply, DIN rail connector

Ambient temperature range
Humidity
Inflammability class in acc. with UL 94
Housing material
Dimensions W/H/D
Screw connection solid/stranded/AWG
Push-in connection solid/stranded/AWG
EMC note

Conformance/Approvals

Conformance
ATEX
UL, USA/Canada

SIL in accordance with IEC 61508

Description
NAMUR signal conditioner
Screw connection
Push-in connection

Technical data

NAMUR proximity sensors (EN 60947-5-6)
open circuit switch contacts
Switch contacts with resistance circuit
~ 8 V DC
> 2.1 mA (conductive) / < 1.2 mA (blocking)
< 0.2 mA
Break 0.05 mA < I_{IN} < 0.35 mA
Short circuit 100 Ω < R_{Sensor} < 360 Ω
Relay output
1 N/O contact per channel
AgSnO₂, hard gold-plated
250 V AC (2 A) / 120 V DC (0.2 A) / 30 V DC (2 A)
500 VA
5 V / 10 mA
10⁷ cycles
Can be inverted via slide switch
≤ 20 Hz (without load)

19.2 V DC ... 30 V DC (24 V DC -20%...+25%)
35 mA (24 V DC)
< 1 W

375 V (Peak value in accordance with EN 60079-11)
375 V (Peak value in accordance with EN 60079-11)
300 V_{rms} (Rated insulation voltage (overvoltage category II; degree of pollution 2, safe isolation as per EN 61010-1))

-20 °C ... 60 °C (Any mounting position)
5 % ... 95 % (non-condensing)
V0
PA 66-FR
12.5 / 99 / 114.5 mm
0.2 ... 2.5 mm² / 0.2 ... 2.5 mm² / 24 - 14
0.2 ... 1.5 mm² / 0.2 ... 1.5 mm² / 24 - 16
Class A product, see page 605

CE-compliant, additionally EN 61326-1
Ex II 3 G Ex nA nC IIC T4 Gc X
UL 508 Listed
UL 61010 Listed
Class I, Div. 2, Groups A, B, C, D T4
Class I, Zone 2, Group IIC T4
2

Ordering data

Type	Order No.	Pcs./ Pkt.
MACX MCR-SL-2NAM-RO	2865049	1
MACX MCR-SL-2NAM-RO-SP	2924294	1

Digital IN
NAMUR signal conditioners

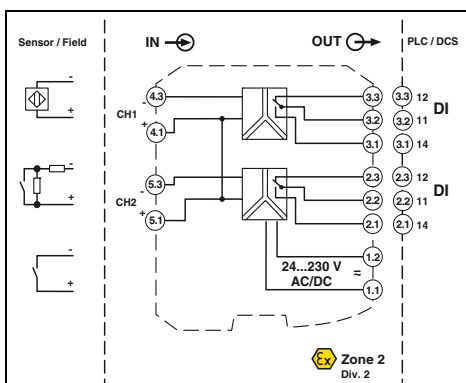
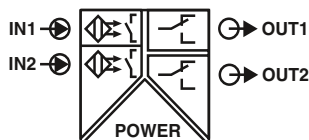

2-channel, signal output: PDT relay, wide-range power supply

Functional Safety

Ex: Ex n

Housing width 17.5 mm

Technical data

Input data

Input signal

- No-load voltage
- Switching points
- Switching hysteresis
- Line fault detection

Switching output

- Contact type
- Contact material
- Max. switching voltage
- Maximum switching capacity
- Recommended minimum load
- Mechanical service life
- Switching behavior
- Maximum switching frequency

General data

Supply voltage range

- Current consumption
- Power dissipation
- Electrical isolation

Input/output
Input/power supply

- Ambient temperature range
- Humidity
- Inflammability class in acc. with UL 94
- Housing material
- Dimensions W/H/D
- Screw connection solid/stranded/AWG
- Push-in connection solid/stranded/AWG
- EMC note

Conformance/Approvals

- Conformance
- ATEX
- UL, USA/Canada

SIL in accordance with IEC 61508

NAMUR proximity sensors (EN 60947-5-6)
open circuit switch contacts
Switch contacts with resistance circuit
~ 8 V DC
> 2.1 mA (conductive) / < 1.2 mA (blocking)
approx. 0.2 mA
Break 0.05 mA < IIN < 0.35 mA
Short circuit 100 Ω < RSensor < 360 Ω

Relay output

- 1 PDT per channel
- AgSnO₂, hard gold-plated
- 250 V AC (2 A, 60 Hz) / 120 V DC (0.2 A) / 30 V DC (2 A)
- 500 VA
- 5 V / 10 mA
- 10⁷ cycles
- can be inverted using DIP switch
- ≤ 20 Hz (Load-dependent)

19.2 V AC/DC ... 253 V AC/DC
(24 V AC/DC ... 230 V AC/DC (-20 % ... +10 %, 50/60 Hz))
< 80 mA ; < 42 mA (24 V DC)
≤ 1.3 W

375 V (Peak value in accordance with EN 60079-11)
375 V (Peak value in accordance with EN 60079-11)
300 V_{rms} (Rated insulation voltage (overvoltage category II; degree of pollution 2, safe isolation as per EN 61010-1))
2.5 kV AC (50 Hz, 1 min., test voltage)

-20 °C ... 60 °C
10 % ... 95 % (non-condensing)
V0
PA 66-FR
17.5 / 99 / 114.5 mm
0.2 ... 2.5 mm² / 0.2 ... 2.5 mm² / 24 - 14
0.2 ... 1.5 mm² / 0.2 ... 1.5 mm² / 24 - 16
Class A product, see page 605

CE-compliant, additionally EN 61326-1
Ex II 3 G Ex nA nC IIC T4 Gc X
UL 508 Listed
UL 61010 Listed
Class I, Div. 2, Groups A, B, C, D T4
Class I, Zone 2, Group IIC T4
2

Ordering data

Description

NAMUR signal conditioner

Screw connection
Push-in connection

Type

MACX MCR-SL-2NAM-R-UP
MACX MCR-SL-2NAM-R-UP-SP

Order No.

2865052
2924304

Pcs./Pkt.

1
1

NAMUR signal conditioner for operating proximity sensors and mechanical contacts

- 2-channel
- Input for NAMUR proximity sensors (EN 60947-5-6), floating contacts or contacts with resistance circuit
- Relay signal output (PDT)
- Reversible direction of action (operating current or closed-circuit current behavior)
- Line fault detection (LFD) can be activated and deactivated, error indicated by red flashing LED and de-excitation of the output relay
- Wide-range power supply of 19.2 to 253 V AC/DC
- LED displays for indicating supply voltage, circuit state, and malfunctions to NAMUR NE 44
- 3-way electrical isolation
- Up to SIL 2 according to IEC 61508
- Installation in Zone 2 permitted

Notes:

Information on resistance circuits and marking material can be found on page 176

Digital IN
NAMUR signal conditioners

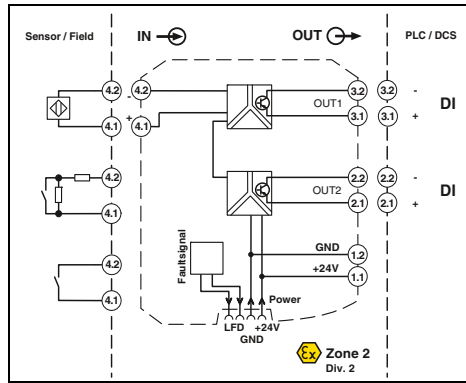
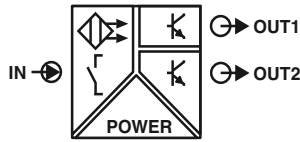

Ex n



2 signal outputs: transistor (passive)

DNV GL Functional Safety

Ex: Ex n

Housing width 12.5 mm

NAMUR signal conditioner for operating proximity sensors and mechanical contacts

- Input for NAMUR proximity sensors (EN 60947-5-6), floating contacts or contacts with resistance circuit
- 2 signal outputs transistor (passive), up to 5 kHz
- Signal output 2 can also be used as a fault signaling output
- Reversible direction of action (operating current or closed-circuit current behavior)
- Line fault detection (LFD) can be activated and deactivated, error indicated by red flashing LED and blocking the transistor output
- Power supply and error indication possible via the DIN rail connector
- LED displays for indicating supply voltage, circuit state, and malfunctions to NAMUR NE 44
- 4-way electrical isolation
- Up to SIL 2 according to IEC 61508
- Installation in Zone 2 permitted

Notes:
Information about the supply and error evaluation module as well as about the DIN rail connectors and marking material can be found from page 174
Information about resistance circuits is given on page 176
Information on "Plug and play" connection using system cabling can be found from page 164

Input data

Input signal

No-load voltage
Switching points
Line fault detection

Switching output

Max. switching voltage
Maximum switching current
Drop (ΔU)
Switching behavior
Maximum switching frequency

General data

Supply voltage range
Current consumption
Power dissipation
Electrical isolation

Input/output

Input/output/supply, DIN rail connector

Input/supply, DIN rail connector

Output 1/output 2

Ambient temperature range
Humidity
Inflammability class in acc. with UL 94
Housing material
Dimensions W/H/D
Screw connection solid/stranded/AWG
Push-in connection solid/stranded/AWG
EMC note

Conformance/Approvals

Conformance
ATEX
UL, USA/Canada

SIL in accordance with IEC 61508

Technical data

NAMUR proximity sensors (EN 60947-5-6)
open circuit switch contacts
Switch contacts with resistance circuit
~ 8 V DC
> 2.1 mA (conductive) / < 1.2 mA (blocking)
Break 0.05 mA < I_{IN} < 0.35 mA
Short circuit 100 Ω < R_{Sensor} < 360 Ω

2 transistor outputs, passive
30 V DC
50 mA (short-circuit-proof)
< 1.4 V
can be inverted using DIP switch
≤ 5 kHz

19.2 V DC ... 30 V DC (24 V DC -20%...+25%)
< 28 mA (24 V DC)
≤ 800 mW

375 V (Peak value in accordance with EN 60079-11)
300 V_{rms} (Rated insulation voltage (overvoltage category II; degree of pollution 2, safe isolation as per EN 61010-1))
2.5 kV (50 Hz, 1 min., test voltage)

375 V (Peak value in accordance with EN 60079-11)
50 V_{rms} (Rated insulation voltage (overvoltage category II; degree of pollution 2, basic insulation as per EN 61010-1))
1 kV (50 Hz, 1 min., test voltage)

-20 °C ... 60 °C (Any mounting position)
10 % ... 95 % (non-condensing)

V0
PA 66-FR
12.5 / 99 / 114.5 mm
0.2 ... 2.5 mm² / 0.2 ... 2.5 mm² / 24 - 14
0.2 ... 1.5 mm² / 0.2 ... 1.5 mm² / 24 - 16
Class A product, see page 605

CE-compliant, additionally EN 61326-1
Ex II 3 G Ex nA IIC T4 Gc X
UL 508 Listed
UL 61010 Listed
Class I, Div. 2, Groups A, B, C, D T4
Class I, Zone 2, Group IIC T4
2

Ordering data

Description
NAMUR signal conditioner
Screw connection
Push-in connection

Type	Order No.	Pcs./ Pkt.
MACX MCR-SL-NAM-2T	2865023	1
MACX MCR-SL-NAM-2T-SP	2924278	1

Digital IN
NAMUR signal conditioners

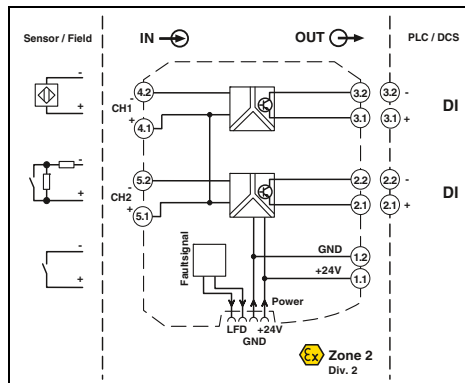
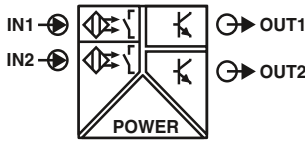

2-channel, signal output: transistor (passive)

Ⓢ DNV GL Functional Safety

Ex: Ⓢ Ex

Housing width 12.5 mm

NAMUR signal conditioner for operating proximity sensors and mechanical contacts

- 2-channel
- Input for NAMUR proximity sensors (EN 60947-5-6), floating contacts or contacts with resistance circuit
- Signal output transistor (passive), up to 5 kHz
- Reversible direction of action (operating current or closed-circuit current behavior)
- Line fault detection (LFD) can be activated and deactivated, error indicated by red flashing LED and blocking the transistor output
- Power supply and error indication possible via the DIN rail connector
- LED displays for indicating supply voltage, circuit state, and malfunctions to NAMUR NE 44
- 3-way electrical isolation
- Up to SIL 2 according to IEC 61508
- Installation in Zone 2 permitted

Input data

Input signal

No-load voltage
Switching points
Line fault detection

Switching output

Max. switching voltage
Maximum switching current
Drop (ΔU)
Switching behavior
Maximum switching frequency

General data

Supply voltage range
Current consumption
Power dissipation
Electrical isolation

Input/output
Input/output/supply, DIN rail connector

Input/supply, DIN rail connector
Output 1/output 2

Ambient temperature range
Humidity
Inflammability class in acc. with UL 94
Housing material
Dimensions W/H/D
Screw connection solid/stranded/AWG
Push-in connection solid/stranded/AWG
EMC note

Conformance/Approvals

Conformance
ATEX
UL, USA/Canada

SIL in accordance with IEC 61508

Technical data

NAMUR proximity sensors (EN 60947-5-6)
open circuit switch contacts
Switch contacts with resistance circuit
~ 8 V DC
> 2.1 mA (conductive) / < 1.2 mA (blocking)
Break 0.05 mA < IIN < 0.35 mA
Short circuit 100 Ω < RSensor < 360 Ω

1 transistor output, passive (per channel)
30 V DC
50 mA (short-circuit-proof)
< 1.4 V
can be inverted using DIP switch
 \leq 5 kHz

19.2 V DC ... 30 V DC (24 V DC -20%...+25%)
< 34 mA (24 V DC)
1000 mW

375 V (Peak value in accordance with EN 60079-11)
300 V_{rms} (Rated insulation voltage (overvoltage category II; degree of pollution 2, safe isolation as per EN 61010-1))
2.5 kV (50 Hz, 1 min., test voltage)

375 V (Peak value in accordance with EN 60079-11)
50 V_{rms} (Rated insulation voltage (overvoltage category II; degree of pollution 2, basic insulation as per EN 61010-1))
1 kV (50 Hz, 1 min., test voltage)

-20 °C ... 60 °C (Any mounting position)
10 % ... 95 % (non-condensing)
V0
PA 66-FR
12.5 / 99 / 114.5 mm
0.2 ... 2.5 mm² / 0.2 ... 2.5 mm² / 24 - 14
0.2 ... 1.5 mm² / 0.2 ... 1.5 mm² / 24 - 16
Class A product, see page 605

CE-compliant, additionally EN 61326
Ⓢ II 3 G Ex nA IIC T4 Gc X
UL 508 Listed
UL 61010 Listed
Class I, Div. 2, Groups A, B, C, D T4
Class I, Zone 2, Group IIC T4
2

Notes:

Information about the supply and error evaluation module as well as about the DIN rail connectors and marking material can be found from page 174

Information about resistance circuits is given on page 176

Information on "Plug and play" connection using system cabling can be found from page 164

Ordering data

Description	Type	Order No.	Pcs./Pkt.	
NAMUR signal conditioner	Screw connection	MACX MCR-SL-2NAM-T	2865036	1
	Push-in connection	MACX MCR-SL-2NAM-T-SP	2924281	1

Analog IN
Repeater power supplies

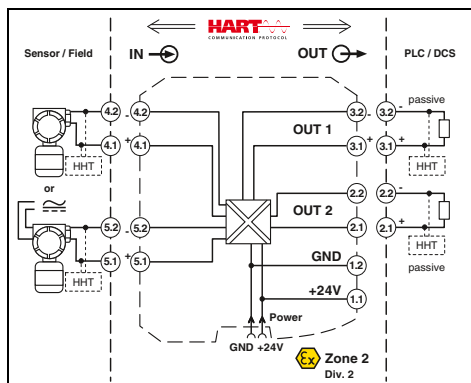
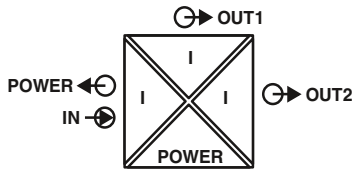

Repeater power supply and input signal conditioner, with two electrically isolated outputs



Housing width 12.5 mm

Technical data

- 4 to 20 mA input, powered and not powered
- Two electrically isolated outputs, 4 to 20 mA (active)
- PL d according to EN ISO 13849-1
- Up to SIL 2 according to IEC 61508
- Installation in Zone 2 possible
- Plug-in screw and Push-in connection technology
- 4-way electrical isolation
- Bidirectional HART communication possible
- Power supply via DIN rail connector possible

Input data

Input signal
Transmitter supply voltage
Voltage drop

Output data

Output signal (Per output)
Load
Output ripple

General data

Supply voltage range
Current consumption
Power dissipation
Temperature coefficient
Step response (10-90%)
Transmission error, typical
Maximum transmission error
Under-/overload range
Electrical isolation

Input/output/power supply

4 mA ... 20 mA / 4 mA ... 20 mA
> 21.5 V (20 mA)
< 3.9 V (in input signal conditioner operation)

4 mA ... 20 mA (active)
< 450 Ω (20 mA)
< 20 mV_{rms}

19.2 V DC ... 30 V DC (24 V DC -20%...+25%)
< 75 mA (24 V DC / 20 mA)
< 1.45 W (24 V DC / 20 mA)
< 0.01 %/K
1.3 ms (for jump 4 mA ... 20 mA, typical)
< 0.05 % (of final value)
< 0.1 % (of final value)
according to NE 43

300 V_{rms} (Rated insulation voltage (overvoltage category II; degree of pollution 2, safe isolation as per EN 61010-1))
2.5 kV (50 Hz, 1 min., test voltage)

Output 1/output 2

1.5 kV AC (50 Hz, 1 min., test voltage)
-20 °C ... 60 °C (Any mounting position)
Green LED (PWR supply voltage)
Yes
HART
PA 66-FR
12.5 / 99 / 114.5 mm
0.2 ... 2.5 mm² / 0.2 ... 2.5 mm² / 24 - 14
0.2 ... 1.5 mm² / 0.2 ... 1.5 mm² / 24 - 16
Class A product, see page 605

Ambient temperature range
Status indication
SMART communication (Per output)
Protocols supported
Housing material
Dimensions W/H/D
Screw connection solid/stranded/AWG
Push-in connection solid/stranded/AWG
EMC note

Conformance/Approvals

Conformance
ATEX
SIL in accordance with IEC 61508
Performance level according to ISO 13849

CE-compliant, additionally EN 61326
Ex II 3 G Ex nA IIC T4 Gc X
2
PLd

Notes:

Information about the supply and error evaluation module as well as about the DIN rail connectors and marking material can be found from page 174

Test plugs for test sockets can be found on page 176

Information on "Plug and play" connection using system cabling can be found from page 164

Description

Repeater power supply and input signal conditioner, signal duplicator, with performance level

Screw connection
Push-in connection

Ordering data

Type	Order No.	Pcs./ Pkt.
MACX PL-RPSSI-2I	2904961	1
MACX PL-RPSSI-2I-SP	2904962	1

Temperature
Temperature transducer

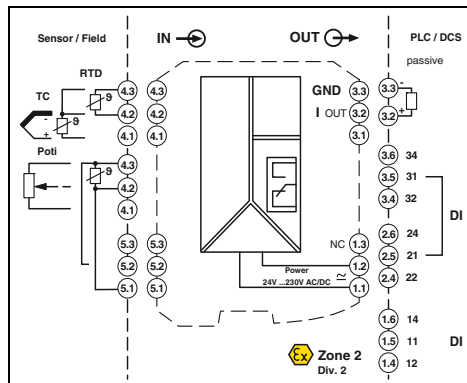
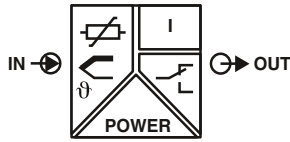

universal, with limit value relays,
wide-range power supply



Housing width 35 mm

Technical data

- Input for resistance thermometers, thermocouples, resistance-type sensors, potentiometers, and mV sources
- A safety-related limit value relay, by bridging two relays
- Differential measurement possible with Pt 100
- An additional limit value relay for non-safety-related function
- PL d according to EN ISO 13849-1
- Up to SIL 2 according to IEC 61508
- Configuration via software (ANALOG-CONF or FDT/DTM)
- Cold junction compensation with separate connector
- Wide range power supply 19.2 to 253 V AC/DC
- Status indicators for supply voltage, cable, sensor, and module errors
- Installation in Zone 2 possible
- Plug-in screw and Push-in connection technology

Input data

Resistance thermometers
Thermocouple sensors

Resistor
Potentiometer
Voltage

Output data

Output signal
Maximum output signal
Load R_B
Behavior in the event of a sensor error

Switching output

Contact type
Contact material
Max. switching voltage
Maximum switching current

General data

Supply voltage range
Power consumption
Temperature coefficient
Maximum transmission error
Electrical isolation

Input/output/power supply

Input/output
Input/power supply
Input/switching output

Ambient temperature range
Humidity
Inflammability class in acc. with UL 94
Housing material
Dimensions W/H/D
Screw connection solid/stranded/AWG
Push-in connection solid/stranded/AWG
EMC note

Conformance/Approvals

Conformance
ATEX
IECEX
SIL in accordance with IEC 61508
Performance level according to ISO 13849

Pt, Ni, Cu sensors: 2, 3, 4-wire
B, E, J, K, N, R, S, T, L, U, CA, DA, A1G, A2G, A3G, MG, LG

0 Ω ... 50 kΩ
0 Ω ... 50 kΩ
-1000 mV ... 1000 mV

4 mA ... 20 mA

22 mA
≤ 600 Ω (at 20 mA)
according to NE 43 or freely configurable

Relay output

2 PDT
AgSnO₂, hard gold-plated
250 V AC (250 V DC)
2 A (250 V AC) / 2 A (28 V DC)

24 V ... 230 V AC/DC (-20 %/+10 %, 50/60 Hz)
< 2.4 W
0.01 %/K
0.1 % (e.g. for Pt 100, 300 K span, 4 ... 20 mA)

300 V_{rms} (Rated insulation voltage (overvoltage category II; degree of pollution 2, safe isolation as per EN 61010-1))
2.5 kV (50 Hz, 1 min., test voltage)

375 V (Peak value in accordance with EN 60079-11)
375 V (Peak value in accordance with EN 60079-11)
375 V (Peak value in accordance with EN 60079-11)
-20 °C ... 65 °C

typ. 5 % ... 95 % (non-condensing)
V0
PA 66-FR
35 / 99 / 114.5 mm
0.2 ... 2.5 mm² / 0.2 ... 2.5 mm² / 24 - 14
0.2 ... 1.5 mm² / 0.2 ... 1.5 mm² / 24 - 16
Class A product, see page 605

CE-compliant

Ex II 3 G Ex nA nC ic IIC T4 Gc X
Ex nA nC ic IIC T4 Gc X
2
PLd

Ordering data

Type	Order No.	Pcs./Pkt.
MACX PL-T-UIREL-UP	2904901	1
MACX PL-T-UIREL-UP-SP	2904903	1

Accessories

IFS-USB-PROG-ADAPTER	2811271	1
MACX MCR-I20	2905680	1

Notes:
The configuration software can be downloaded from the Internet (phoenixcontact.net/products).
Information on the IFS-OP-UNIT operating and display unit and the associated IFS-OP-CRADLE DIN rail cradle can be found on page 171
For information on the programming adapter, refer to page 172

Description
Temperature transducer and threshold value switch with performance level
Screw connection
Push-in connection

Programming adapter for configuring modules with S-PORT interface
Connector, for current signals between +20 mA and -20 mA

Analog IN

Repeater power supply, Ex i

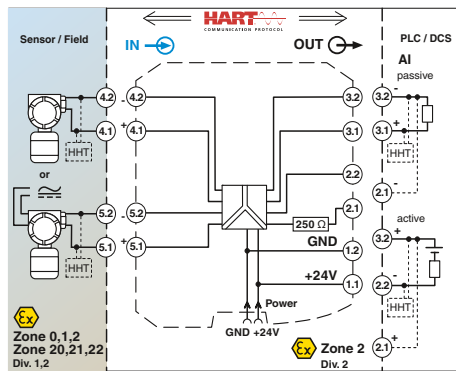
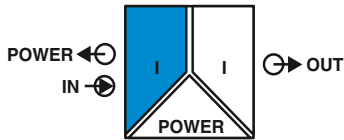

Repeater power supply and input signal conditioner

Functional Safety
 Ex: Ex EAC Ex
 Housing width 12.5 mm

Repeater power supply and input signal conditioner for the operation of intrinsically safe (Ex i) 2-wire measuring transducers, 4-wire measuring transducers, and mA current sources installed in Ex areas.

- 0/4 to 20 mA input, [Ex ia] (powered or not powered)
- 0/4 to 20 mA output (active or passive)
- Bidirectional transmission of digital HART communication signals
- Plug-in screw or Push-in connection technology, with integrated sockets for HART communicators
- Terminal point with 250 Ω resistor to increase the HART impedance in the case of low-impedance systems
- 3-way electrical isolation
- Power supply via DIN rail connector possible
- Up to SIL 2 according to IEC 61508
- Installation in Zone 2 permitted

Notes:
Information about the supply and error evaluation module as well as about the DIN rail connectors and marking material can be found from page 174
Test plugs for test sockets can be found on page 176
Information on "Plug and play" connection using system cabling can be found from page 164

Input data	Input signal Transmitter supply voltage Voltage drop
Output data	Output signal
Load	Output ripple
General data	Supply voltage range Current consumption
Power dissipation	Temperature coefficient Step response (10-90%)
Transmission error, typical	Maximum transmission error Under-/overload range Electrical isolation
Ambient temperature range	Humidity Status indication SMART communication Signal bandwidth Protocols supported Inflammability class in acc. with UL 94 Housing material Dimensions W/H/D Screw connection solid/stranded/AWG Push-in connection solid/stranded/AWG EMC note
Safety data as per ATEX	Maximum output voltage U _o Maximum output current I _o Maximum output power P _o Maximum voltage U _m
Conformance/Approvals	Conformance ATEX IECEX UL, USA/Canada
SIL in accordance with IEC 61508	

Technical data

Input/output/power supply	4 mA ... 20 mA > 16 V (20 mA) < 3.5 V (in input signal conditioner operation)
Output data	4 mA ... 20 mA (active) 4 mA ... 20 mA (14 ... 26 V ext. source voltage) < 1000 Ω (20 mA) < 20 mV _{rms}
Power dissipation	19.2 V DC ... 30 V DC (24 V DC -20%...+25%) < 76 mA (24 V DC / 20 mA / 1000 Ω) ; < 55 mA (24 V DC / 20 mA / 250 Ω) < 1.1 W (24 V DC / 20 mA / 1000 Ω) < 0.95 W (24 V DC / 20 mA / 250 Ω) < 1.2 W (24 V DC / 20 mA / 0 Ω) < 0.01 %/K < 200 μs (for jump 4 mA ... 20 mA, load 600)
Transmission error, typical	< 0.05 % (of final value) < 0.1 % (of final value) according to NE 43
Input/output/power supply	300 V _{rms} (Rated insulation voltage (overvoltage category II; degree of pollution 2, safe isolation as per EN 61010-1)) 2.5 kV (50 Hz, 1 min., test voltage)
Input/output	375 V (Peak value in accordance with EN 60079-11)
Input/power supply	375 V (Peak value in accordance with EN 60079-11) -20 °C ... 60 °C (Any mounting position) 10 % ... 95 % (non-condensing) Green LED (supply voltage) Yes as per HART specifications HART V0 PA 66-FR 12.5 / 112.5 / 114.5 mm 0.2 ... 2.5 mm ² / 0.2 ... 2.5 mm ² / 24 - 14 0.2 ... 1.5 mm ² / 0.2 ... 1.5 mm ² / 24 - 16 Class A product, see page 605
Safety data as per ATEX	25.2 V 93 mA 587 mW 253 V AC (125 V DC)
Conformance/Approvals	CE-compliant, additionally EN 61326 Ex II (1) G [Ex ia Ga] IIC/IIB Ex II (1) D [Ex ia Da] IIIC Ex II 3 (1) G Ex nA [ia Ga] IIC/IIB T4 Gc Ex I (M1) [Ex ia Ma] I [Ex ia Ga] IIC/IIB , [Ex ia Da] IIIC , Ex nA [ia Ga] IIC/IIB T4 Gc UL 61010 Listed Class I Div 2; IS for Class I, II, III Div 1 2

Ordering data

Description	Type	Order No.	Pcs./Pkt.
Repeater power supply, smart, intrinsically safe input			
Screw connection	MACX MCR-EX-SL-RPSSI-I	2865340	1
Push-in connection	MACX MCR-EX-SL-RPSSI-I-SP	2924016	1

Analog IN

Repeater power supply, Ex i

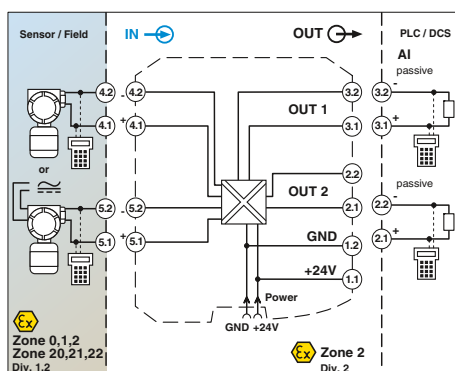
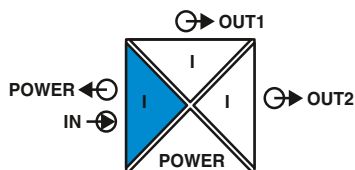

Repeater power supply and input signal conditioner, with two electrically isolated outputs

Functional Safety

Ex: EAC Ex
Housing width 12.5 mm

Technical data

Input data	
Input signal	4 mA ... 20 mA / 0 mA ... 20 mA
Transmitter supply voltage	> 16 V (20 mA)
Voltage drop	approx. 3.9 V (in input signal conditioner operation)
Output data	
Output signal (Per output)	4 mA ... 20 mA (Output 1 and output 2 active)
Load	
Output ripple	< 450 Ω (20 mA)
General data	
Supply voltage range	19.2 V DC ... 30 V DC (24 V DC -20%...+25%)
Current consumption	< 75 mA (24 V DC / 20 mA)
Power dissipation	< 1.45 W (24 V DC / 20 mA)
Temperature coefficient	< 0.01 %/K
Step response (10-90%)	1.3 ms (for jump 4 mA ... 20 mA, typical)
Transmission error, typical	< 0.05 % (of final value)
Maximum transmission error	< 0.1 % (of final value)
Under-/overload range	according to NE 43
Electrical isolation	
Input/output/power supply	300 V _{rms} (Rated insulation voltage (overvoltage category II; degree of pollution 2, safe isolation as per EN 61010-1)) 2.5 kV (50 Hz, 1 min., test voltage)
Input/output	375 V (Peak value in accordance with EN 60079-11)
Input/power supply	375 V (Peak value in accordance with EN 60079-11)
Output 1/output 2	1.5 kV AC (50 Hz, 1 min., test voltage)
Ambient temperature range	-20 °C ... 60 °C (Any mounting position)
Status indication	Green LED (PWR supply voltage)
SMART communication (Per output)	Yes
Protocols supported	HART
Housing material	PA 66-FR
Dimensions W/H/D	12.5 / 99 / 114.5 mm
Screw connection solid/stranded/AWG	0.2 ... 2.5 mm ² / 0.2 ... 2.5 mm ² / 24 - 14
Push-in connection solid/stranded/AWG	0.2 ... 1.5 mm ² / 0.2 ... 1.5 mm ² / 24 - 16
EMC note	Class A product, see page 605
Safety data as per ATEX	
Maximum output voltage U _o	25.2 V
Maximum output current I _o	93 mA
Maximum output power P _o	587 mW
Maximum voltage U _m	253 V AC (125 V DC)
Conformance/Approvals	
Conformance	CE-compliant, additionally EN 61326
ATEX	Ex II (1) G [Ex ia Ga] IIC/IIB Ex II (1) D [Ex ia Da] IIIC Ex II 3 (1) G Ex nA [ia Ga] IIC/IIB T4 Gc [Ex ia Ga] IIC/IIB, [Ex ia Da] IIIC, Ex nA [ia Ga] IIC/IIB T4 Gc Class I Div 2; IS for Class I, II, III Div 1
IECEX	
UL, USA/Canada	
SIL in accordance with IEC 61508	2

Notes:

Information about the supply and error evaluation module as well as about the DIN rail connectors and marking material can be found from page 174

Test plugs for test sockets can be found on page 176

Information on "Plug and play" connection using system cabling can be found from page 164

Ordering data				
Description	Type	Order No.	Pcs./Pkt.	
Repeater power supply, smart, intrinsically safe input	Screw connection	MACX MCR-EX-SL-RPSSI-2I	2865366	1
	Push-in connection	MACX MCR-EX-SL-RPSSI-2I-SP	2924236	1
With just one HART-transparent output	Screw connection	MACX MCR-EX-SL-RPSSI-2I-1S	2908855	1
	Push-in connection	MACX MCR-EX-SL-RPSSI-2I-1S-SP	2908856	1

Analog IN

Repeater power supply, Ex i

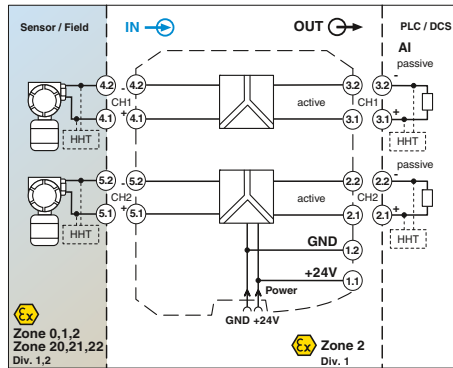
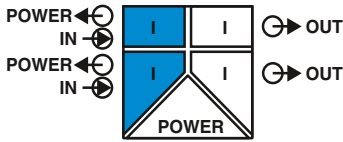

2-channel repeater power supply

Functional Safety
 Ex: EAC Ex
 Housing width 12.5 mm

Repeater power supply for the operation of intrinsically safe (Ex i) 2-wire measuring transducers installed in the Ex area.

- 2-channel
- 4 to 20 mA input, [Ex ia] (powered)
- 4 to 20 mA output (active)
- Bidirectional transmission of digital HART communication signals
- Plug-in screw or Push-in connection technology, with integrated sockets for HART communicators
- Safe 3-way electrical isolation
- Power supply via DIN rail connector possible
- Up to SIL 3 according to IEC 61508
- Installation in Zone 2 permitted

Notes:
Information on the supply and error evaluation module, DIN rail connectors, system cabling, and marking material can be found from page 174
Test plugs for test sockets can be found on page 176
Information on "Plug and play" connection using system cabling can be found from page 164

Input data	
Input signal	
Transmitter supply voltage	
Underload/overload signal range	
Output data	
Output signal	
Load	
Underload/overload signal range	
General data	
Supply voltage range	
Current consumption	
Power dissipation	
Temperature coefficient	
Step response (10-90%)	
Transmission error, typical	
Maximum transmission error	
Electrical isolation	
Input/output, power supply	
Input/output	
Input/power supply	
Output 1/output 2/ power supply	
Ambient temperature range	
Status indication	
SMART communication	
Signal bandwidth	
Protocols supported	
Housing material	
Dimensions W/H/D	
Screw connection solid/stranded/AWG	
Push-in connection solid/stranded/AWG	
EMC note	
Safety data as per ATEX	
Maximum output voltage U _o	
Maximum output current I _o	
Maximum output power P _o	
Maximum voltage U _m	
Conformance/Approvals	
Conformance	
ATEX	
IECEX	
UL, USA/Canada	
SIL in accordance with IEC 61508	

Technical data

per channel	
4 mA ... 20 mA	
> 16 V (20 mA)	
0 mA ... 24 mA	
per channel	
4 mA ... 20 mA (active)	
≤ 450 Ω (20 mA)	
0 mA ... 24 mA	
19.2 V DC ... 30 V DC (24 V DC -20%...+25%)	
< 100 mA (24 V / 20 mA)	
< 1.4 W (at 24 V DC / 20 mA)	
< 0.01 %/K	
< 1.3 ms (for 4 mA ... 20 mA step)	
< 0.05 % (of final value)	
< 0.1 % (of final value)	
300 V _{rms} (Rated insulation voltage (overvoltage category II; degree of pollution 2, safe isolation as per EN 61010-1))	
2.5 kV (50 Hz, 1 min., test voltage)	
375 V (Peak value in accordance with EN 60079-11)	
375 V (Peak value in accordance with EN 60079-11)	
1.5 kV (50 Hz, 1 min., test voltage)	
-20 °C ... 60 °C (Any mounting position)	
Green LED (supply voltage)	
Yes	
as per HART specifications	
HART	
PA 66-FR	
12.5 / 99 / 114.5 mm	
0.2 ... 2.5 mm ² / 0.2 ... 2.5 mm ² / 24 - 14	
0.2 ... 1.5 mm ² / 0.2 ... 1.5 mm ² / 24 - 16	
Class A product, see page 605	
25.2 V	
93 mA	
587 mW	
253 V AC (125 V DC)	
CE-compliant, additionally EN 61326	
Ex II (1) G [Ex ia Ga] IIC/IIB	
Ex II (1) D [Ex ia Da] IIIC	
Ex II 3(1) G Ex nA [ia Ga] IIC T4 Gc	
[Ex ia Ga] IIC/IIB , [Ex ia Da] IIIC , Ex nA [ia Ga] IIC T4 Gc	
Class I Div 2; IS for Class I, II, III Div 1	
3	

Ordering data

Description	Type	Order No.	Pcs./ Pkt.
Repeater power supply, 2-channel, smart, intrinsically safe input			
Screw connection	MACX MCR-EX-SL-RPSS-2I-2I	2865382	1
Push-in connection	MACX MCR-EX-SL-RPSS-2I-2I-SP	2924676	1

Analog IN

Repeater power supply with wide range power supply, Ex i

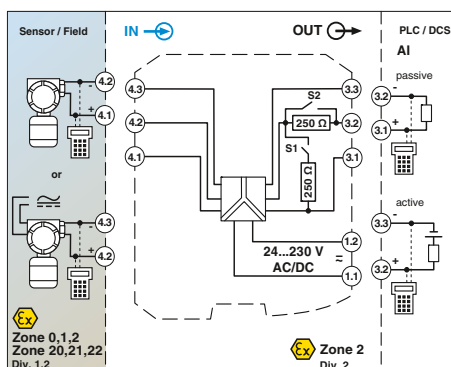
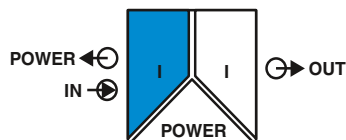

Repeater power supply and input signal conditioner, wide-range power supply

Functional Safety
 Ex: EAC Ex // Applied for: GL
 Housing width 17.5 mm

Repeater power supply and input signal conditioner for the operation of intrinsically safe (Ex i) 2-wire measuring transducers, 4-wire measuring transducers, and mA current sources installed in Ex areas.

- 0/4 to 20 mA input, [Ex ia] (powered or not powered)
- 0/4 to 20 mA output (active or passive), 0/1 to 5 V, can be selected via DIP switch
- Bidirectional transmission of digital HART communication signals
- Plug-in screw or Push-in connection technology, with integrated sockets for HART communicators
- 250 Ω resistor that can be activated via DIP switches to increase the HART impedance in the case of low-impedance systems
- 3-way electrical isolation
- Wide-range power supply of 19.2 to 253 V AC/DC
- Up to SIL 2 according to IEC 61508
- Installation in Zone 2 permitted

Notes:

Information on marking material can be found on page 177
Test plugs for test sockets can be found on page 176

Input data	
Input signal	4 mA ... 20 mA
Transmitter supply voltage	> 16 V (20 mA)
Voltage drop	< 3.5 V (in input signal conditioner operation)
Output data	
Output signal (configurable using the DIP switch)	4 mA ... 20 mA (active) 4 mA ... 20 mA (14 ... 26 V ext. source voltage) 1 V ... 5 V (internal resistance, 250 Ω, 0.1%) Configurable via DIP switches
Load	< 600 Ω (20 mA)
Output ripple	< 20 mV _{rms}
General data	
Supply voltage range	24 V ... 230 V AC/DC (-20 %/+10 %, 50/60 Hz)
Current consumption	< 80 mA (24 V DC / 20 mA)
Power dissipation	< 1.6 W (24 V DC/ 20 mA)
Temperature coefficient	< 0.01 %/K
Step response (10-90%)	< 600 μs (for 4 mA ... 20 mA step)
Transmission error, typical	< 0.05 % (of final value)
Maximum transmission error	< 0.1 % (of final value)
Under-/overload range	according to NE 43
Electrical isolation	
	Input/output/power supply 300 V _{rms} (Rated insulation voltage (overvoltage category II; degree of pollution 2, safe isolation as per EN 61010-1)) 2.5 kV (50 Hz, 1 min., test voltage)
	Input/output 375 V (Peak value in accordance with EN 60079-11)
	Input/power supply 375 V (Peak value in accordance with EN 60079-11)
Ambient temperature range	-20 °C ... 60 °C (Any mounting position)
Humidity	10 % ... 95 % (non-condensing)
Status indication	Green LED (supply voltage)
SMART communication	Yes
Signal bandwidth	as per HART specifications
Protocols supported	HART
Inflammability class in acc. with UL 94	V0
Housing material	PA 66-FR
Dimensions W/H/D	17.5 / 99 / 114.5 mm
Screw connection solid/stranded/AWG	0.2 ... 2.5 mm ² / 0.2 ... 2.5 mm ² / 24 - 14
Push-in connection solid/stranded/AWG	0.2 ... 1.5 mm ² / 0.2 ... 1.5 mm ² / 24 - 16
EMC note	Class A product, see page 605
Safety data as per ATEX	
Maximum output voltage U _o	25.2 V
Maximum output current I _o	93 mA
Maximum output power P _o	587 mW
Maximum voltage U _m	253 V AC/DC (Supply terminals) 253 V AC (Output terminals) 125 V DC (Output terminals)
Conformance/Approvals	
Conformance	CE-compliant, additionally EN 61326
ATEX	Ex II (1) G [Ex ia Ga] IIC/IIB Ex II (1) D [Ex ia Da] IIIC Ex II 3(1) G Ex nA [ia Ga] IIC/IIB T4 Gc [Ex ia Ga] IIC/IIB, [Ex ia Da] IIIC, Ex nA [ia Ga] IIC/IIB T4 Gc Class I Div 2; IS for Class I, II, III Div 1
IECEX	2
UL, USA/Canada	
SIL in accordance with IEC 61508	

Technical data

Technical data	
Input signal	4 mA ... 20 mA
Transmitter supply voltage	> 16 V (20 mA)
Voltage drop	< 3.5 V (in input signal conditioner operation)
Output signal (configurable using the DIP switch)	4 mA ... 20 mA (active) 4 mA ... 20 mA (14 ... 26 V ext. source voltage) 1 V ... 5 V (internal resistance, 250 Ω, 0.1%) Configurable via DIP switches
Load	< 600 Ω (20 mA)
Output ripple	< 20 mV _{rms}
Supply voltage range	24 V ... 230 V AC/DC (-20 %/+10 %, 50/60 Hz)
Current consumption	< 80 mA (24 V DC / 20 mA)
Power dissipation	< 1.6 W (24 V DC/ 20 mA)
Temperature coefficient	< 0.01 %/K
Step response (10-90%)	< 600 μs (for 4 mA ... 20 mA step)
Transmission error, typical	< 0.05 % (of final value)
Maximum transmission error	< 0.1 % (of final value)
Under-/overload range	according to NE 43
Electrical isolation	
	Input/output/power supply 300 V _{rms} (Rated insulation voltage (overvoltage category II; degree of pollution 2, safe isolation as per EN 61010-1)) 2.5 kV (50 Hz, 1 min., test voltage)
	Input/output 375 V (Peak value in accordance with EN 60079-11)
	Input/power supply 375 V (Peak value in accordance with EN 60079-11)
Ambient temperature range	-20 °C ... 60 °C (Any mounting position)
Humidity	10 % ... 95 % (non-condensing)
Status indication	Green LED (supply voltage)
SMART communication	Yes
Signal bandwidth	as per HART specifications
Protocols supported	HART
Inflammability class in acc. with UL 94	V0
Housing material	PA 66-FR
Dimensions W/H/D	17.5 / 99 / 114.5 mm
Screw connection solid/stranded/AWG	0.2 ... 2.5 mm ² / 0.2 ... 2.5 mm ² / 24 - 14
Push-in connection solid/stranded/AWG	0.2 ... 1.5 mm ² / 0.2 ... 1.5 mm ² / 24 - 16
EMC note	Class A product, see page 605
Safety data as per ATEX	
Maximum output voltage U _o	25.2 V
Maximum output current I _o	93 mA
Maximum output power P _o	587 mW
Maximum voltage U _m	253 V AC/DC (Supply terminals) 253 V AC (Output terminals) 125 V DC (Output terminals)
Conformance/Approvals	
Conformance	CE-compliant, additionally EN 61326
ATEX	Ex II (1) G [Ex ia Ga] IIC/IIB Ex II (1) D [Ex ia Da] IIIC Ex II 3(1) G Ex nA [ia Ga] IIC/IIB T4 Gc [Ex ia Ga] IIC/IIB, [Ex ia Da] IIIC, Ex nA [ia Ga] IIC/IIB T4 Gc Class I Div 2; IS for Class I, II, III Div 1
IECEX	2
UL, USA/Canada	
SIL in accordance with IEC 61508	

Ordering data

Description	Type	Order No.	Pcs./Pkt.	
Repeater power supply, smart, intrinsically safe input	Screw connection	MACX MCR-EX-SL-RPSSI-I-UP	2865793	1
	Push-in connection	MACX MCR-EX-SL-RPSSI-I-UP-SP	2924029	1

Analog OUT
Output signal conditioner, Ex i

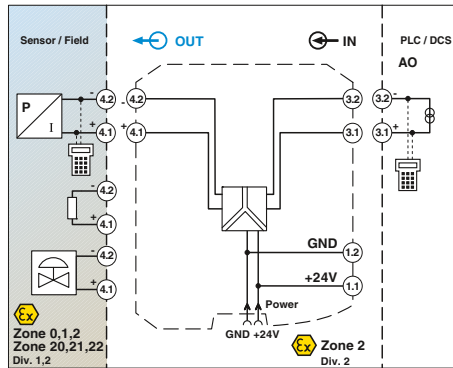
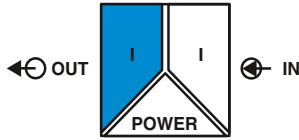

UL DNV GL Functional Safety
Ex: EAC Ex
Housing width 12.5 mm

Output signal conditioner for controlling intrinsically safe (Ex i) I/P converters, control valves, and indicators installed in Ex areas.

- 0/4 to 20 mA input
- 0/4 to 20 mA output, [Ex ia] IIC
- Bidirectional transmission of digital HART communication signals
- Plug-in screw or Push-in connection technology, with integrated sockets for HART communicators
- Line fault detection (LF)
- 3-way electrical isolation
- Power supply via DIN rail connector possible
- Up to SIL 2 according to IEC 61508
- Installation in Zone 2 permitted

Notes:
Information about the supply and error evaluation module as well as about the DIN rail connectors and marking material can be found from page 174
Test plugs for test sockets can be found on page 176
Information on "Plug and play" connection using system cabling can be found from page 164

Input data	
Input signal	
Input voltage	
Input impedance in the event of a cable break at the output	
Output data	
Output signal	
Load	
Output ripple	
General data	
Supply voltage range	
Current consumption	
Power dissipation	
Temperature coefficient	
Step response (10-90%)	
Maximum transmission error	
Electrical isolation	
Ambient temperature range	
Humidity	
Status indication	
SMART communication	
Signal bandwidth	
Protocols supported	
Inflammability class in acc. with UL 94	
Housing material	
Dimensions W/H/D	
Screw connection solid/stranded/AWG	
Push-in connection solid/stranded/AWG	
EMC note	
Safety data as per ATEX	
Maximum output voltage U _o	
Maximum output current I _o	
Maximum output power P _o	
Maximum voltage U _m	
Conformance/Approvals	
Conformance	
ATEX	
IECEX	
UL, USA/Canada	
SIL in accordance with IEC 61508	

Technical data	
0 mA ... 20 mA / 4 mA ... 20 mA	
5.4 V (at 20 mA)	
> 100 kΩ (if there is a line fault)	
0 mA ... 20 mA (intrinsically safe) / 4 mA ... 20 mA (intrinsically safe)	
< 800 Ω (at 20 mA)	
< 20 mV _{rms}	
19.2 V DC ... 30 V DC (24 V DC -20%...+25%)	
< 46 mA (at 24 V DC / 20 mA)	
< 1.1 W (at 24 V DC / 20 mA)	
< 0.01 %/K	
< 140 μs (for 4 mA ... 20 mA step)	
< 0.1 % (of final value)	
Input/output/power supply	1.5 kV (50 Hz, 1 min., test voltage) 300 V _{rms} (Rated insulation voltage (overvoltage category II, degree of pollution 2))
Output/input	375 V (Peak value in accordance with EN 60079-11)
Output/supply	375 V (Peak value in accordance with EN 60079-11) -20 °C ... 60 °C (Any mounting position) 10 % ... 95 % (non-condensing) Green LED (supply voltage) Yes as per HART specifications HART V0 PA 66-FR 12.5 / 99 / 114.5 mm 0.2 ... 2.5 mm ² / 0.2 ... 2.5 mm ² / 24 - 14 0.2 ... 1.5 mm ² / 0.2 ... 1.5 mm ² / 24 - 16 Class A product, see page 605
	27.7 V 92 mA 633 mW 253 V AC (125 V DC)
	CE-compliant, additionally EN 61326 Ex II (1) G [Ex ia Ga] IIC/IIB Ex II (1) D [Ex ia Da] IIIC Ex II 3(1) G Ex nA [ia Ga] IIC/IIB T4 Gc [Ex ia Ga] IIC/IIB, [Ex ia Da] IIIC, Ex nA [ia Ga] IIC/IIB T4 Gc Class I Div 2; IS for Class I, II, III Div 1 2

Description
Output signal conditioner, smart, output intrinsically safe
Screw connection
Push-in connection

Ordering data		
Type	Order No.	Pcs./ Pkt.
MACX MCR-EX-SL-IDS-I	2865405	1
MACX MCR-EX-SL-IDS-I-SP	2924032	1

Temperature
Temperature transducer, Ex i

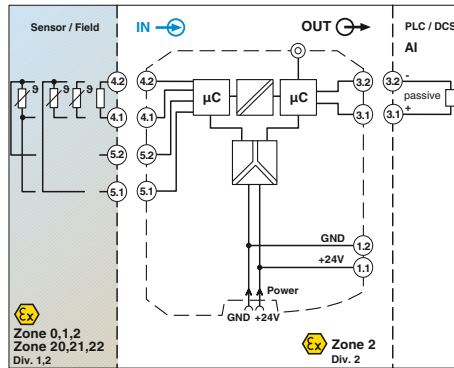
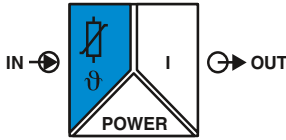

For resistance thermometers and resistance-type sensors

Housing width 12.5 mm

Technical data

Input data	Resistance thermometers Resistor Cable resistance Sensor input current Measuring range span	Sensors (2-, 3-, 4-wire) 0 Ω ... 2000 Ω ≤ 50 Ω per cable 200 µA ... 1 mA min. 50 K
Output data	Output signal Load Behavior in the event of a sensor error Output ripple	0 mA ... 20 mA / 4 mA ... 20 mA ≤ 500 Ω As per NE 43 or can be freely defined < 50 µA _{pp}
General data	Supply voltage range Current draw Power dissipation Temperature coefficient Step response (0–99%)	19.2 V DC ... 30 V DC (24 V DC -20%...+25%) ≤ 40 mA (at 24 V DC) < 1 W 0.01 %/K typ. 700 ms ≤ 1100 ms 0.1 % x 1000 [K]/measuring span ± 5 % / ± 5 %
	Transmission error, total ZERO / SPAN adjustment Electrical isolation	300 V _{rms} (Rated insulation voltage (overvoltage category II; degree of pollution 2, safe isolation as per EN 61010-1)) 2.5 kV (50 Hz, 1 min., test voltage)
	Ambient temperature range Humidity Status indication	Input/output 375 V (Peak value in accordance with EN 60079-11) Input/power supply 375 V (Peak value in accordance with EN 60079-11) -20 °C ... 60 °C (Any mounting position) 5 % ... 95 % (non-condensing) Green LED (supply voltage, PWR) Red LED, flashing (line, sensor error, ERR) Red LED (module error, ERR) V0 12.5 / 99 / 114.5 mm 0.2 ... 2.5 mm ² / 0.2 ... 2.5 mm ² / 24 - 14 0.2 ... 1.5 mm ² / 0.2 ... 1.5 mm ² / 24 - 16 Class A product, see page 605
Safety data as per ATEX	Maximum output voltage U _o Maximum output current I _o Maximum output power P _o	6 V 6.3 mA 9.4 mW
Conformance/Approvals	Conformance ATEX IECEX UL, USA/Canada	CE-compliant, additionally EN 61326 [Ex ia Ga] IIC , [Ex ia Da] IIIC , Ex nA ic [ia Ga] IIC T4 Gc X Class I Div 2; IS for Class I, II, III Div 1

Programmable temperature transducer for intrinsically safe operation of resistance thermometers and resistance-type sensors installed in Ex areas. The measured values are converted into a linear 0 to 20 mA or 4 to 20 mA signal.

- Input for resistance thermometers and resistance-type sensors, [Ex ia]
- 0 to 20 mA or 4 to 20 mA output
- Configuration via software (FDT/DTM): Sensor type, connection method, measuring range, measuring unit, filter, alarm signal, and output range
- Programming during operation with Ex measuring circuit connected and also voltage-free using IFS-USB-PROG-ADAPTER programming adapter
- Status indicator for supply voltage, cable, sensor, and module errors
- 3-way electrical isolation possible
- Installation in Zone 2 permitted

Notes:
To order a product with an order configuration, please enter the desired configuration by referring to the order key provided online (phoenixcontact.net/products).
The configuration software can be downloaded from the Internet (phoenixcontact.net/products).
Information about the supply and error evaluation module as well as about the DIN rail connectors and marking material can be found from page 174
For information on the programming adapter, refer to page 172
Information on "Plug and play" connection using system cabling can be found from page 164

Description	
Temperature transducer for resistance thermometers, intrinsically safe input	
Order configuration	Screw connection
Order configuration	Push-in connection
Standard configuration	Screw connection
Standard configuration	Push-in connection

Programming adapter for configuring modules with S-PORT interface
--

Ordering data

Type	Order No.	Pcs./Pkt.
MACX MCR-EX-SL-RTD-I	2865939	1
MACX MCR-EX-SL-RTD-I-SP	2924142	1
MACX MCR-EX-SL-RTD-I-NC	2865573	1
MACX MCR-EX-SL-RTD-I-SP-NC	2924168	1

Accessories

IFS-USB-PROG-ADAPTER	2811271	1
----------------------	---------	---

Temperature

Temperature transducer, Ex i

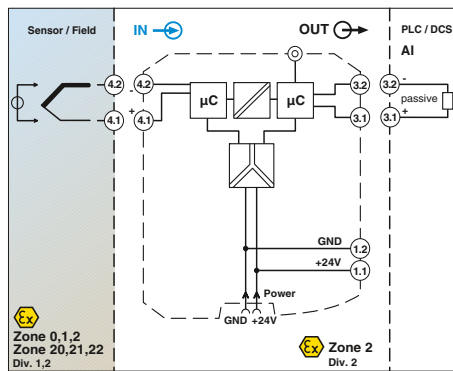
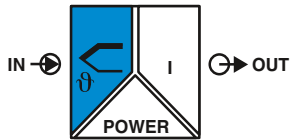

For thermocouples and mV sources

Ex:

 Housing width 12.5 mm

Programmable temperature transducer for intrinsically safe operation of thermocouples and mV sources installed in Ex areas. The measured values are converted into a linear 0 to 20 mA or 4 to 20 mA signal.

- Input for thermocouples and mV sources, [Ex ia]
- 0 to 20 mA or 4 to 20 mA output
- Configuration via software (FDT/DTM): Sensor type, connection method, measuring range, measuring unit, filter, alarm signal, and output range
- Programming during operation with Ex measuring circuit connected and also voltage-free using IFS-USB-PROG-ADAPTER programming adapter
- Status indicator for supply voltage, cable, sensor, and module errors
- 3-way electrical isolation
- Power supply via DIN rail connector possible
- Installation in Zone 2 permitted

Notes:
To order a product with an order configuration, please enter the desired configuration by referring to the order key provided online (phoenixcontact.net/products).
The configuration software can be downloaded from the Internet (phoenixcontact.net/products).
Information about the supply and error evaluation module as well as about the DIN rail connectors and marking material can be found from page 174
For information on the programming adapter, refer to page 172
Information on "Plug and play" connection using system cabling can be found from page 164

Input data	Thermocouple sensors
Voltage	
Measuring range span	
Output data	
Output signal	
Load	
Behavior in the event of a sensor error	
Output ripple	
General data	
Supply voltage range	
Current consumption	
Power dissipation	
Temperature coefficient	
Step response (0–99%)	
Transmission error, total	
Cold junction errors	
ZERO / SPAN adjustment	
Electrical isolation	
Ambient temperature range	
Humidity	
Status indication	
Inflammability class in acc. with UL 94	
Housing material	
Dimensions W/H/D	
Screw connection solid/stranded/AWG	
EMC note	
Safety data as per ATEX	
Maximum output voltage U _o	
Maximum output current I _o	
Maximum output power P _o	
Maximum voltage U _m	
Conformance/Approvals	
Conformance	
ATEX	
IECEX	
UL, USA/Canada	

Technical data	
E, J, K, N as per IEC / EN 60584, L as per DIN 43760	
-20 mV ... 70 mV	
Min. 50 K for thermocouples, 3 mV for mV sources	
0 mA ... 20 mA / 4 mA ... 20 mA	
≤ 500 Ω	
As per NE 43 or can be freely defined	
< 50 µA _{pp}	
19.2 V DC ... 30 V DC (24 V DC -20%...+25%)	
< 40 mA (24 V DC)	
< 1 W	
0.01 %/K	
typ. 700 ms	
≤ 1100 ms	
0.1 % x 600 [K]/measuring span; 0.1 % > 600 [K]	
± 1 K	
± 5 % / ± 5 %	
300 V _{rms} (Rated insulation voltage (overvoltage category II; degree of pollution 2, safe isolation as per EN 61010-1))	
2.5 kV (50 Hz, 1 min., test voltage)	
375 V (Peak value in accordance with EN 60079-11)	
375 V (Peak value in accordance with EN 60079-11)	
-20 °C ... 60 °C (Any mounting position)	
5 % ... 95 % (non-condensing)	
Green LED (supply voltage, PWR)	
Red LED, flashing (line, sensor error, ERR)	
Red LED (module error, ERR)	
V0	
PA 66-FR	
12.5 / 99 / 114.5 mm	
0.2 ... 2.5 mm ² / 0.2 ... 2.5 mm ² / 24 - 14	
Class A product, see page 605	
6 V	
4.7 mA	
7 mW	
253 V AC (125 V DC)	
CE-compliant, additionally EN 61326	
[Ex ia Ga] IIC/IIB	
[Ex ia Da] IIIC	
Ex nA ic [ia Ga] IIC T4 Gc X	
[Ex ia Ga] IIC/IIB, [Ex ia Da] IIIC, Ex nA ic [ia Ga] IIC T4 Gc	
Class I Div 2; IS for Class I, II, III Div 1	

Description	Order configuration	Screw connection
Temperature transducer for thermocouples , intrinsically safe input		
Standard configuration		Screw connection

Programming adapter for configuring modules with S-PORT interface	
--	--

Ordering data		
Type	Order No.	Pcs./Pkt.
MACX MCR-EX-SL-TC-I	2865942	1
MACX MCR-EX-SL-TC-I-NC	2865586	1

Accessories		
Type	Order No.	Pcs./Pkt.
IFS-USB-PROG-ADAPTER	2811271	1

Temperature
Temperature transducer, Ex i

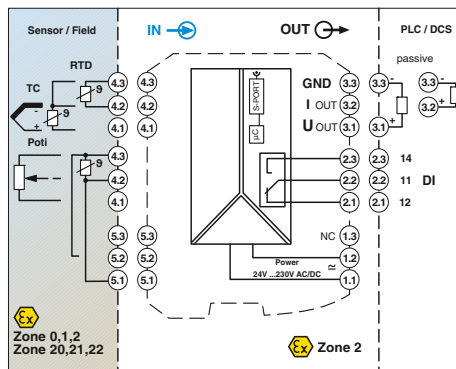
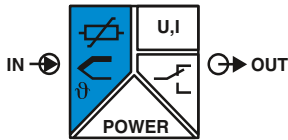

Universal, with switching output, wide-range power supply

Functional Safety
Ex: EAC Ex
Housing width 17.5 mm

Universal temperature transducer with freely configurable properties for intrinsically safe operation of resistance thermometers, thermocouples, resistance-type sensors, and potentiometers installed in Ex areas

- Input for resistance thermometers, thermocouples, resistance-type sensors, potentiometers, and mV sources, [Ex ia]
- Measure differential temperatures
- Freely programmable input and output
- Option of inverse output signal ranges
- Relay switching output
- Configuration via software (FDT/DTM) or IFS-OP-UNIT operator interface and display unit
- Programming during operation with Ex measuring circuit connected and also voltage-free using IFS-USB-PROG-ADAPTER programming adapter
- Plug-in screw or Push-in connection technology
- Cold junction compensation with separate connector
- Wide-range power supply of 19.2 to 253 V AC/DC
- Status indicator for supply voltage, cable, sensor, and module errors
- Up to SIL 2 according to IEC 61508
- Installation in Zone 2 permitted

Input data

Resistance thermometers
Thermocouple sensors

Resistor
Potentiometer
Voltage

Output data
Output signal

Maximum output signal
Load R_B

Behavior in the event of a sensor error

Switching output

Contact type
Contact material
Max. switching voltage
Maximum switching current

General data

Supply voltage range
Power consumption
Temperature coefficient
Transmission error, total
Electrical isolation

Input/output/power supply

Input/output
Input/power supply
Input/switching output
Output/supply

Ambient temperature range

Humidity
Inflammability class in acc. with UL 94
Housing material
Dimensions W/H/D
Screw connection solid/stranded/AWG
Push-in connection solid/stranded/AWG

EMC note

Safety data as per ATEX

Maximum output voltage U_o
Maximum output current I_o
Maximum output power P_o

Conformance/Approvals

Conformance
ATEX

IECEX

SIL in accordance with IEC 61508

Technical data

Pt, Ni, Cu sensors: 2, 3, 4-wire
B, E, J, K, N, R, S, T, L, U, CA, DA, A1G, A2G, A3G, MG, LG

0 Ω ... 50 k Ω
0 Ω ... 50 k Ω
-1000 mV ... 1000 mV

U output I output
4 mA ... 20 mA (in the case of SIL; further free configuration without SIL)

\pm 11 V 22 mA
 \geq 10 k Ω \leq 600 Ω (20 mA)

according to NE 43 or freely configurable

Switching output

1 PDT
AgSnO₂, hard gold-plated
30 V AC (30 V DC)
0.5 A (30 V AC) / 1 A (30 V DC)

24 V ... 230 V AC/DC (-20 %/+10 %, 50/60 Hz)
< 1.5 W
0.01 %/K
< 0.1 % (e.g., for Pt 100, 300 K span, 4 ... 20 mA)

2.5 kV (50 Hz, 1 min., test voltage)
375 V (Peak value in accordance with EN 60079-11)
375 V (Peak value in accordance with EN 60079-11)
375 V (Peak value in accordance with EN 60079-11)
300 V_{rms} (Rated insulation voltage (overvoltage category II; degree of pollution 2, safe isolation as per EN 61010-1))

-20 °C ... 65 °C

typ. 5 % ... 95 % (non-condensing)

V0

PA 66-FR

17.5 / 99 / 114.5 mm

0.2 ... 2.5 mm² / 0.2 ... 2.5 mm² / 24 - 14

0.2 ... 1.5 mm² / 0.2 ... 1.5 mm² / 24 - 16

Class A product, see page 605

6 V

7.4 mA

11 mW

CE-compliant

Ex II (1) G [Ex ia Ga] IIC

Ex II (1) D [Ex ia Da] IIIC

Ex II 3 G Ex nA nC ic IIC T4 Gc X

[Ex ia Ga] IIC, [Ex ia Da] IIIC, nEx nA nC ic IIC T4 Gc X

2

Ordering data

Type	Order No.	Pcs./Pkt.
MACX MCR-EX-T-UI-UP	2865654	1
MACX MCR-EX-T-UI-UP-SP	2924689	1
MACX MCR-EX-T-UI-UP-C	2811763	1
MACX MCR-EX-T-UI-UP-SP-C	2924692	1

Accessories

IFS-USB-PROG-ADAPTER	2811271	1
----------------------	---------	---

Notes:

To order a product with an order configuration, enter the required configuration by referring to the adjacent order key.

The configuration software can be downloaded from the Internet (phoenixcontact.net/products).

Information on the IFS-OP-UNIT operating and display unit and the associated IFS-OP-CRADLE DIN rail cradle can be found on page 171

For information on the programming adapter, refer to page 105

Description

Temperature transducer, intrinsically safe input

Standard configuration	Screw connection
Standard configuration	Push-in connection
Order configuration	Screw connection
Order configuration	Push-in connection

Programming adapter for configuring modules with S-PORT interface

Ex i signal conditioners with SIL functional safety – MACX Analog Ex

Order key for MACX MCR-EX-T-UI-UP(-SP)-C temperature transducers (standard configuration entered as an example)

Order No.	Safety Integrity Level (SIL)	Sensor type	Connection technology	Cold junction compensation	Measuring range:		Measuring unit	Output range	Factory calibration certificate = FCC																																																																																																																																																										
					Start	End																																																																																																																																																													
2811763	ON	PT100	4	0	-50	150	C	OUT02	NONE																																																																																																																																																										
2811763 ≙ MACX MCR-EX-T-UI-UP-C	ON ≙ Active NONE ≙ Not active	See below	2 ≙ 2-conductor 3 ≙ 3-conductor 4 ≙ 4-conductor	0 ≙ Off, e.g., with RTD, R, potentiometer, mV 1 ≙ On, e.g., with TC	See below	See below	C ≙ °C F ≙ °F O ≙ Ω P ≙ % V ≙ mV	OUT15 ≙ 0 ... 5 mA OUT16 ≙ 0 ... 10 mA OUT01 ≙ 0 ... 20 mA OUT15 ≙ 0 ... 5 mA OUT25 ≙ 1 ... 5 mA OUT26 ≙ 2 ... 10 mA OUT02 ≙ 4 ... 20 mA OUT05 ≙ 0 ... 5 V OUT03 ≙ 0 ... 10 V OUT06 ≙ 1 ... 5 V OUT04 ≙ 2 ... 10 V OUT13 ≙ -5 ... +5 V OUT14 ≙ -10 ... +10 V Others can be freely configured in the software	NONE ≙ Without FCC YES ≙ With FCC (a fee is charged) YESPLUS ≙ FCC with 5 measuring points (a fee is charged)																																																																																																																																																										
2924692 ≙ MACX MCR-EX-T-UI-UP-SP-C	ON only with output range = OUT02																																																																																																																																																																		
<p>Resistance thermometers (RTD) Others can be selected or freely configured in the software.</p> <table border="1"> <thead> <tr> <th>Model</th> <th>Sensor</th> <th>Start</th> <th>End</th> <th>Unit</th> <th>Smallest measuring range span</th> <th>Other setting options can be configured with the IFS-CONF software:</th> </tr> </thead> <tbody> <tr><td>PT100</td><td>Pt 100 according to IEC 751</td><td>-200</td><td>850</td><td>°C</td><td>20 K</td><td>- Freely configurable user characteristic curve with 30 interpolation points</td></tr> <tr><td>PT200</td><td>Pt 200 according to IEC 751</td><td>-200</td><td>850</td><td>°C</td><td>20 K</td><td></td></tr> <tr><td>PT500</td><td>Pt 500 according to IEC 751</td><td>-200</td><td>850</td><td>°C</td><td>20 K</td><td></td></tr> <tr><td>PT1000</td><td>Pt 1000 according to IEC 751</td><td>-200</td><td>850</td><td>°C</td><td>20 K</td><td>- Output behavior in the event of a short circuit, sensor break or overrange/underrange can be freely configured or set according to NE43 (standard configuration: NE43 upscale)</td></tr> <tr><td>PT100S</td><td>Pt 100 according to Sama RC21-4-1966</td><td>-200</td><td>850</td><td>°C</td><td>20 K</td><td></td></tr> <tr><td>PT1000S</td><td>Pt 1000 according to Sama RC21-4-1966</td><td>-200</td><td>850</td><td>°C</td><td>20 K</td><td></td></tr> <tr><td>PT100G</td><td>Pt 100 according to GOST 6651-2009 (α = 0.00385)</td><td>-200</td><td>850</td><td>°C</td><td>20 K</td><td></td></tr> <tr><td>PT1000G</td><td>Pt 1000 according to GOST 6651-2009 (α = 0.00385)</td><td>-200</td><td>850</td><td>°C</td><td>20 K</td><td>- Filter setting (standard configuration: 1)</td></tr> <tr><td>PT100J</td><td>Pt 100 according to JIS C1604/1997</td><td>-200</td><td>850</td><td>°C</td><td>20 K</td><td></td></tr> <tr><td>PT1000J</td><td>Pt 1000 according to JIS C1604/1997</td><td>-200</td><td>850</td><td>°C</td><td>20 K</td><td>- Restart after failsafe (standard configuration: ON)</td></tr> <tr><td>NI100</td><td>Ni 100 according to DIN 43760/DIN IEC 60751</td><td>-60</td><td>250</td><td>°C</td><td>20 K</td><td></td></tr> <tr><td>NI1000</td><td>Ni 1000 according to DIN 43760/DIN IEC 60751</td><td>-60</td><td>250</td><td>°C</td><td>20 K</td><td></td></tr> <tr><td>NI100S</td><td>Ni 100 according to Sama RC21-4-1966</td><td>-60</td><td>180</td><td>°C</td><td>20 K</td><td>- Switching behavior: switching output (limit values, times, etc.) (standard configuration: OFF)</td></tr> <tr><td>NI1000S</td><td>Ni 1000 according to Sama RC21-4-1966</td><td>-60</td><td>180</td><td>°C</td><td>20 K</td><td></td></tr> <tr><td>NI1000L</td><td>Ni 1000 (Landis & Gyr)</td><td>-50</td><td>160</td><td>°C</td><td>20 K</td><td></td></tr> <tr><td>CU10</td><td>Cu 10 according to Sama RC21-4-1966</td><td>-70</td><td>500</td><td>°C</td><td>100 K</td><td></td></tr> <tr><td>CU50</td><td>Cu 50 according to GOST 6651-2009 (α = 0.00428)</td><td>-50</td><td>200</td><td>°C</td><td>100 K</td><td></td></tr> <tr><td>CU100</td><td>Cu 100 according to GOST 6651-2009 (α = 0.00428)</td><td>-50</td><td>200</td><td>°C</td><td>100 K</td><td></td></tr> <tr><td>CU53</td><td>Cu 53 according to GOST 6651-2009 (α = 0.00426)</td><td>-50</td><td>180</td><td>°C</td><td>100 K</td><td></td></tr> <tr><td>KTY81</td><td>KTY81-110 (Philips)</td><td>-55</td><td>150</td><td>°C</td><td>20 K</td><td></td></tr> <tr><td>KTY84</td><td>KTY84-130 (Philips)</td><td>-40</td><td>300</td><td>°C</td><td>20 K</td><td></td></tr> </tbody> </table>										Model	Sensor	Start	End	Unit	Smallest measuring range span	Other setting options can be configured with the IFS-CONF software:	PT100	Pt 100 according to IEC 751	-200	850	°C	20 K	- Freely configurable user characteristic curve with 30 interpolation points	PT200	Pt 200 according to IEC 751	-200	850	°C	20 K		PT500	Pt 500 according to IEC 751	-200	850	°C	20 K		PT1000	Pt 1000 according to IEC 751	-200	850	°C	20 K	- Output behavior in the event of a short circuit, sensor break or overrange/underrange can be freely configured or set according to NE43 (standard configuration: NE43 upscale)	PT100S	Pt 100 according to Sama RC21-4-1966	-200	850	°C	20 K		PT1000S	Pt 1000 according to Sama RC21-4-1966	-200	850	°C	20 K		PT100G	Pt 100 according to GOST 6651-2009 (α = 0.00385)	-200	850	°C	20 K		PT1000G	Pt 1000 according to GOST 6651-2009 (α = 0.00385)	-200	850	°C	20 K	- Filter setting (standard configuration: 1)	PT100J	Pt 100 according to JIS C1604/1997	-200	850	°C	20 K		PT1000J	Pt 1000 according to JIS C1604/1997	-200	850	°C	20 K	- Restart after failsafe (standard configuration: ON)	NI100	Ni 100 according to DIN 43760/DIN IEC 60751	-60	250	°C	20 K		NI1000	Ni 1000 according to DIN 43760/DIN IEC 60751	-60	250	°C	20 K		NI100S	Ni 100 according to Sama RC21-4-1966	-60	180	°C	20 K	- Switching behavior: switching output (limit values, times, etc.) (standard configuration: OFF)	NI1000S	Ni 1000 according to Sama RC21-4-1966	-60	180	°C	20 K		NI1000L	Ni 1000 (Landis & Gyr)	-50	160	°C	20 K		CU10	Cu 10 according to Sama RC21-4-1966	-70	500	°C	100 K		CU50	Cu 50 according to GOST 6651-2009 (α = 0.00428)	-50	200	°C	100 K		CU100	Cu 100 according to GOST 6651-2009 (α = 0.00428)	-50	200	°C	100 K		CU53	Cu 53 according to GOST 6651-2009 (α = 0.00426)	-50	180	°C	100 K		KTY81	KTY81-110 (Philips)	-55	150	°C	20 K		KTY84	KTY84-130 (Philips)	-40	300	°C	20 K	
Model	Sensor	Start	End	Unit	Smallest measuring range span	Other setting options can be configured with the IFS-CONF software:																																																																																																																																																													
PT100	Pt 100 according to IEC 751	-200	850	°C	20 K	- Freely configurable user characteristic curve with 30 interpolation points																																																																																																																																																													
PT200	Pt 200 according to IEC 751	-200	850	°C	20 K																																																																																																																																																														
PT500	Pt 500 according to IEC 751	-200	850	°C	20 K																																																																																																																																																														
PT1000	Pt 1000 according to IEC 751	-200	850	°C	20 K	- Output behavior in the event of a short circuit, sensor break or overrange/underrange can be freely configured or set according to NE43 (standard configuration: NE43 upscale)																																																																																																																																																													
PT100S	Pt 100 according to Sama RC21-4-1966	-200	850	°C	20 K																																																																																																																																																														
PT1000S	Pt 1000 according to Sama RC21-4-1966	-200	850	°C	20 K																																																																																																																																																														
PT100G	Pt 100 according to GOST 6651-2009 (α = 0.00385)	-200	850	°C	20 K																																																																																																																																																														
PT1000G	Pt 1000 according to GOST 6651-2009 (α = 0.00385)	-200	850	°C	20 K	- Filter setting (standard configuration: 1)																																																																																																																																																													
PT100J	Pt 100 according to JIS C1604/1997	-200	850	°C	20 K																																																																																																																																																														
PT1000J	Pt 1000 according to JIS C1604/1997	-200	850	°C	20 K	- Restart after failsafe (standard configuration: ON)																																																																																																																																																													
NI100	Ni 100 according to DIN 43760/DIN IEC 60751	-60	250	°C	20 K																																																																																																																																																														
NI1000	Ni 1000 according to DIN 43760/DIN IEC 60751	-60	250	°C	20 K																																																																																																																																																														
NI100S	Ni 100 according to Sama RC21-4-1966	-60	180	°C	20 K	- Switching behavior: switching output (limit values, times, etc.) (standard configuration: OFF)																																																																																																																																																													
NI1000S	Ni 1000 according to Sama RC21-4-1966	-60	180	°C	20 K																																																																																																																																																														
NI1000L	Ni 1000 (Landis & Gyr)	-50	160	°C	20 K																																																																																																																																																														
CU10	Cu 10 according to Sama RC21-4-1966	-70	500	°C	100 K																																																																																																																																																														
CU50	Cu 50 according to GOST 6651-2009 (α = 0.00428)	-50	200	°C	100 K																																																																																																																																																														
CU100	Cu 100 according to GOST 6651-2009 (α = 0.00428)	-50	200	°C	100 K																																																																																																																																																														
CU53	Cu 53 according to GOST 6651-2009 (α = 0.00426)	-50	180	°C	100 K																																																																																																																																																														
KTY81	KTY81-110 (Philips)	-55	150	°C	20 K																																																																																																																																																														
KTY84	KTY84-130 (Philips)	-40	300	°C	20 K																																																																																																																																																														
<p>Thermocouples (TC) Others can be selected in the software.</p> <table border="1"> <thead> <tr> <th>Model</th> <th>Sensor</th> <th>Start</th> <th>End</th> <th>Unit</th> <th>Smallest measuring range span</th> <th>Other setting options can be configured with the IFS-CONF software:</th> </tr> </thead> <tbody> <tr><td>B</td><td>according to IEC 584-1 (Pt30Rh-Pt6Rh)</td><td>500</td><td>1820</td><td>°C</td><td>50 K</td><td></td></tr> <tr><td>E</td><td>according to IEC 584-1 (NiCr-CuNi)</td><td>-230</td><td>1000</td><td>°C</td><td>50 K</td><td></td></tr> <tr><td>J</td><td>according to IEC 584-1 (Fe-CuNi)</td><td>-210</td><td>1200</td><td>°C</td><td>50 K</td><td></td></tr> <tr><td>K</td><td>according to IEC 584-1 (NiCr-Ni)</td><td>-250</td><td>1372</td><td>°C</td><td>50 K</td><td></td></tr> <tr><td>N</td><td>according to IEC 584-1 (NiCrSi-NiSi)</td><td>-250</td><td>1300</td><td>°C</td><td>50 K</td><td></td></tr> <tr><td>R</td><td>according to IEC 584-1 (Pt13Rh-Pt)</td><td>-50</td><td>1768</td><td>°C</td><td>50 K</td><td></td></tr> <tr><td>S</td><td>according to IEC 584-1 (Pt10Rh-Pt)</td><td>-50</td><td>1768</td><td>°C</td><td>50 K</td><td></td></tr> <tr><td>T</td><td>according to IEC 584-1 (Cu-CuNi)</td><td>-200</td><td>400</td><td>°C</td><td>50 K</td><td></td></tr> <tr><td>L</td><td>according to DIN 43760 (Fe-CuNi)</td><td>-200</td><td>900</td><td>°C</td><td>50 K</td><td></td></tr> <tr><td>U</td><td>according to DIN 43760 (Cu-CuNi)</td><td>-200</td><td>600</td><td>°C</td><td>50 K</td><td></td></tr> <tr><td>CA</td><td>C ASTM JE988 (2002)</td><td>0</td><td>2315</td><td>°C</td><td>50 K</td><td></td></tr> <tr><td>DA</td><td>D ASTM JE988 (2002)</td><td>0</td><td>2315</td><td>°C</td><td>50 K</td><td></td></tr> <tr><td>A1G</td><td>A-1 GOST 8.585-2001</td><td>0</td><td>2500</td><td>°C</td><td>50 K</td><td></td></tr> <tr><td>A2G</td><td>A-2 GOST 8.585-2001</td><td>0</td><td>1800</td><td>°C</td><td>50 K</td><td></td></tr> <tr><td>A3G</td><td>A-3 GOST 8.585-2001</td><td>0</td><td>1800</td><td>°C</td><td>50 K</td><td></td></tr> <tr><td>MG</td><td>M GOST 8.585-2001</td><td>-200</td><td>100</td><td>°C</td><td>50 K</td><td></td></tr> <tr><td>LG</td><td>L GOST 8.585-2001</td><td>-200</td><td>800</td><td>°C</td><td>50 K</td><td></td></tr> </tbody> </table>										Model	Sensor	Start	End	Unit	Smallest measuring range span	Other setting options can be configured with the IFS-CONF software:	B	according to IEC 584-1 (Pt30Rh-Pt6Rh)	500	1820	°C	50 K		E	according to IEC 584-1 (NiCr-CuNi)	-230	1000	°C	50 K		J	according to IEC 584-1 (Fe-CuNi)	-210	1200	°C	50 K		K	according to IEC 584-1 (NiCr-Ni)	-250	1372	°C	50 K		N	according to IEC 584-1 (NiCrSi-NiSi)	-250	1300	°C	50 K		R	according to IEC 584-1 (Pt13Rh-Pt)	-50	1768	°C	50 K		S	according to IEC 584-1 (Pt10Rh-Pt)	-50	1768	°C	50 K		T	according to IEC 584-1 (Cu-CuNi)	-200	400	°C	50 K		L	according to DIN 43760 (Fe-CuNi)	-200	900	°C	50 K		U	according to DIN 43760 (Cu-CuNi)	-200	600	°C	50 K		CA	C ASTM JE988 (2002)	0	2315	°C	50 K		DA	D ASTM JE988 (2002)	0	2315	°C	50 K		A1G	A-1 GOST 8.585-2001	0	2500	°C	50 K		A2G	A-2 GOST 8.585-2001	0	1800	°C	50 K		A3G	A-3 GOST 8.585-2001	0	1800	°C	50 K		MG	M GOST 8.585-2001	-200	100	°C	50 K		LG	L GOST 8.585-2001	-200	800	°C	50 K																													
Model	Sensor	Start	End	Unit	Smallest measuring range span	Other setting options can be configured with the IFS-CONF software:																																																																																																																																																													
B	according to IEC 584-1 (Pt30Rh-Pt6Rh)	500	1820	°C	50 K																																																																																																																																																														
E	according to IEC 584-1 (NiCr-CuNi)	-230	1000	°C	50 K																																																																																																																																																														
J	according to IEC 584-1 (Fe-CuNi)	-210	1200	°C	50 K																																																																																																																																																														
K	according to IEC 584-1 (NiCr-Ni)	-250	1372	°C	50 K																																																																																																																																																														
N	according to IEC 584-1 (NiCrSi-NiSi)	-250	1300	°C	50 K																																																																																																																																																														
R	according to IEC 584-1 (Pt13Rh-Pt)	-50	1768	°C	50 K																																																																																																																																																														
S	according to IEC 584-1 (Pt10Rh-Pt)	-50	1768	°C	50 K																																																																																																																																																														
T	according to IEC 584-1 (Cu-CuNi)	-200	400	°C	50 K																																																																																																																																																														
L	according to DIN 43760 (Fe-CuNi)	-200	900	°C	50 K																																																																																																																																																														
U	according to DIN 43760 (Cu-CuNi)	-200	600	°C	50 K																																																																																																																																																														
CA	C ASTM JE988 (2002)	0	2315	°C	50 K																																																																																																																																																														
DA	D ASTM JE988 (2002)	0	2315	°C	50 K																																																																																																																																																														
A1G	A-1 GOST 8.585-2001	0	2500	°C	50 K																																																																																																																																																														
A2G	A-2 GOST 8.585-2001	0	1800	°C	50 K																																																																																																																																																														
A3G	A-3 GOST 8.585-2001	0	1800	°C	50 K																																																																																																																																																														
MG	M GOST 8.585-2001	-200	100	°C	50 K																																																																																																																																																														
LG	L GOST 8.585-2001	-200	800	°C	50 K																																																																																																																																																														
<p>Remote resistance-type sensors (R) (2-, 3-, 4-conductor) Others can be selected in the software.</p> <table border="1"> <thead> <tr> <th>Model</th> <th>Sensor</th> <th>Start</th> <th>End</th> <th>Unit</th> <th>Smallest measuring range span</th> <th>Other setting options can be configured with the IFS-CONF software:</th> </tr> </thead> <tbody> <tr><td>RES03</td><td>Resistance 0 ... 150 Ω</td><td>0</td><td>150</td><td>Ω</td><td rowspan="6">10% of the selected measuring range</td><td></td></tr> <tr><td>RES05</td><td>Resistance 0 ... 600 Ω</td><td>0</td><td>600</td><td>Ω</td></tr> <tr><td>RES06</td><td>Resistance 0 ... 1200 Ω</td><td>0</td><td>1200</td><td>Ω</td></tr> <tr><td>RES09</td><td>Resistance 0 ... 6250 Ω</td><td>0</td><td>6250</td><td>Ω</td></tr> <tr><td>RES10</td><td>Resistance 0 ... 12,500 Ω</td><td>0</td><td>12,500</td><td>Ω</td></tr> <tr><td>RES12</td><td>Resistance 0 ... 50,000 Ω</td><td>0</td><td>50,000</td><td>Ω</td></tr> </tbody> </table>										Model	Sensor	Start	End	Unit	Smallest measuring range span	Other setting options can be configured with the IFS-CONF software:	RES03	Resistance 0 ... 150 Ω	0	150	Ω	10% of the selected measuring range		RES05	Resistance 0 ... 600 Ω	0	600	Ω	RES06	Resistance 0 ... 1200 Ω	0	1200	Ω	RES09	Resistance 0 ... 6250 Ω	0	6250	Ω	RES10	Resistance 0 ... 12,500 Ω	0	12,500	Ω	RES12	Resistance 0 ... 50,000 Ω	0	50,000	Ω																																																																																																																			
Model	Sensor	Start	End	Unit	Smallest measuring range span	Other setting options can be configured with the IFS-CONF software:																																																																																																																																																													
RES03	Resistance 0 ... 150 Ω	0	150	Ω	10% of the selected measuring range																																																																																																																																																														
RES05	Resistance 0 ... 600 Ω	0	600	Ω																																																																																																																																																															
RES06	Resistance 0 ... 1200 Ω	0	1200	Ω																																																																																																																																																															
RES09	Resistance 0 ... 6250 Ω	0	6250	Ω																																																																																																																																																															
RES10	Resistance 0 ... 12,500 Ω	0	12,500	Ω																																																																																																																																																															
RES12	Resistance 0 ... 50,000 Ω	0	50,000	Ω																																																																																																																																																															
<p>Potentiometers (3-conductor) Others can be selected in the software.</p> <table border="1"> <thead> <tr> <th>Model</th> <th>Sensor</th> <th>Start</th> <th>End</th> <th>Unit</th> <th>Smallest measuring range span</th> <th>Other setting options can be configured with the IFS-CONF software:</th> </tr> </thead> <tbody> <tr><td>POT03</td><td>Potentiometer 0 ... 150 Ω</td><td>0</td><td>100</td><td>%</td><td rowspan="6">10% of the selected measuring range</td><td></td></tr> <tr><td>POT05</td><td>Potentiometer 0 ... 600 Ω</td><td>0</td><td>100</td><td>%</td></tr> <tr><td>POT06</td><td>Potentiometer 0 ... 1200 Ω</td><td>0</td><td>100</td><td>%</td></tr> <tr><td>POT09</td><td>Potentiometer 0 ... 6250 Ω</td><td>0</td><td>100</td><td>%</td></tr> <tr><td>POT10</td><td>Potentiometer 0 ... 12,500 Ω</td><td>0</td><td>100</td><td>%</td></tr> <tr><td>POT12</td><td>Potentiometer 0 ... 50,000 Ω</td><td>0</td><td>100</td><td>%</td></tr> </tbody> </table>										Model	Sensor	Start	End	Unit	Smallest measuring range span	Other setting options can be configured with the IFS-CONF software:	POT03	Potentiometer 0 ... 150 Ω	0	100	%	10% of the selected measuring range		POT05	Potentiometer 0 ... 600 Ω	0	100	%	POT06	Potentiometer 0 ... 1200 Ω	0	100	%	POT09	Potentiometer 0 ... 6250 Ω	0	100	%	POT10	Potentiometer 0 ... 12,500 Ω	0	100	%	POT12	Potentiometer 0 ... 50,000 Ω	0	100	%																																																																																																																			
Model	Sensor	Start	End	Unit	Smallest measuring range span	Other setting options can be configured with the IFS-CONF software:																																																																																																																																																													
POT03	Potentiometer 0 ... 150 Ω	0	100	%	10% of the selected measuring range																																																																																																																																																														
POT05	Potentiometer 0 ... 600 Ω	0	100	%																																																																																																																																																															
POT06	Potentiometer 0 ... 1200 Ω	0	100	%																																																																																																																																																															
POT09	Potentiometer 0 ... 6250 Ω	0	100	%																																																																																																																																																															
POT10	Potentiometer 0 ... 12,500 Ω	0	100	%																																																																																																																																																															
POT12	Potentiometer 0 ... 50,000 Ω	0	100	%																																																																																																																																																															
<p>Voltage signals (mV) Others can be selected in the software.</p> <table border="1"> <thead> <tr> <th>Model</th> <th>Sensor</th> <th>Start</th> <th>End</th> <th>Unit</th> <th>Smallest measuring range span</th> <th>Other setting options can be configured with the IFS-CONF software:</th> </tr> </thead> <tbody> <tr><td>V04</td><td>Voltage (mV)</td><td>-1000</td><td>+1000</td><td>mV</td><td>10% of nominal span</td><td></td></tr> </tbody> </table>										Model	Sensor	Start	End	Unit	Smallest measuring range span	Other setting options can be configured with the IFS-CONF software:	V04	Voltage (mV)	-1000	+1000	mV	10% of nominal span																																																																																																																																													
Model	Sensor	Start	End	Unit	Smallest measuring range span	Other setting options can be configured with the IFS-CONF software:																																																																																																																																																													
V04	Voltage (mV)	-1000	+1000	mV	10% of nominal span																																																																																																																																																														

Temperature conversion guide for °C to °F: $T [°F] = \frac{9}{5} T [°C] + 32$

Temperature
Temperature transducer, Ex i

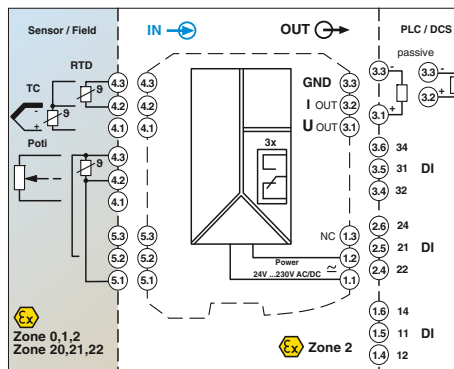
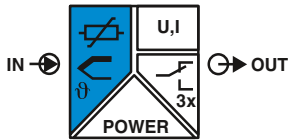

Universal, with three limit value relays, wide-range power supply

Functional Safety
Ex: EAC Ex
Housing width 35 mm

Universal temperature transducer with freely configurable properties for intrinsically safe operation of resistance thermometers, thermocouples, resistance-type sensors, and potentiometers installed in Ex areas

- Input for resistance thermometers, thermocouples, resistance-type sensors, potentiometers, and mV sources, [Ex ia]
- Measure differential temperatures
- Freely programmable input and output
- Option of inverse output signal ranges
- Three limit value relays, can be used in combination as a safe limit value relay
- Configuration via software (FDT/DTM) or IFS-OP-UNIT operator interface and display unit
- Programming during operation with Ex measuring circuit connected and also voltage-free using IFS-USB-PROG-ADAPTER programming adapter
- Plug-in screw or Push-in connection technology
- Cold junction compensation with separate connector
- Wide-range power supply of 19.2 to 253 V AC/DC
- Status indicator for supply voltage, cable, sensor, and module errors
- Up to SIL 2 according to IEC 61508
- Installation in Zone 2 permitted

Notes:

The configuration software can be downloaded from the Internet (phoenixcontact.net/products).

Information on the IFS-OP-UNIT operating and display unit and the associated IFS-OP-CRADLE DIN rail cradle can be found on page 171

For information on the programming adapter, refer to page 172

Input data	Resistance thermometers Thermocouple sensors
Resistor Potentiometer Voltage	
Output data	Output signal
Maximum output signal Load R_B Behavior in the event of a sensor error	
Switching output	Contact type Contact material Max. switching voltage Maximum switching current
General data	Supply voltage range Power consumption Temperature coefficient Maximum transmission error Electrical isolation
Ambient temperature range Humidity Inflammability class in acc. with UL 94 Housing material Dimensions W/H/D Screw connection solid/stranded/AWG Push-in connection solid/stranded/AWG EMC note	
Safety data as per ATEX	Maximum output voltage U_o Maximum output current I_o Maximum output power P_o
Conformance/Approvals	Conformance ATEX
IECEX SIL in accordance with IEC 61508	

Technical data	
Pt, Ni, Cu sensors: 2, 3, 4-wire B, E, J, K, N, R, S, T, L, U, CA, DA, A1G, A2G, A3G, MG, LG	
0 Ω ... 50 k Ω 0 Ω ... 50 k Ω -1000 mV ... 1000 mV	
U output 0 mA ... 20 mA \pm 10 V (in the case of SIL; further free configuration without SIL)	I output 22 mA \leq 600 Ω (20 mA)
\pm 11 V \geq 10 k Ω	according to NE 43 or freely configurable
Relay output	3 PDTs AgSnO ₂ , hard gold-plated 250 V AC (250 V DC) 2 A (250 V AC) / 2 A (28 V DC)
24 V ... 230 V AC/DC (-20 %/+10 %, 50/60 Hz) < 2.4 W 0.01 %/K 0.1 % (e.g. for Pt 100, 300 K span, 4 ... 20 mA)	
Input/output/power supply Input/output Input/power supply Input/switching output Output/supply	2.5 kV (50 Hz, 1 min., test voltage) 375 V (Peak value in accordance with EN 60079-11) 375 V (Peak value in accordance with EN 60079-11) 375 V (Peak value in accordance with EN 60079-11) 300 V _{rms} (Rated insulation voltage (overvoltage category II; degree of pollution 2, safe isolation as per EN 61010-1))
-20 °C ... 65 °C typ. 5 % ... 95 % (non-condensing) V0 PA 66-FR 35 / 99 / 114.5 mm 0.2 ... 2.5 mm ² / 0.2 ... 2.5 mm ² / 24 - 14 0.2 ... 1.5 mm ² / 0.2 ... 1.5 mm ² / 24 - 16 Class A product, see page 605	
6 V 7.4 mA 11 mW	
CE-compliant Ex II (1) G [Ex ia Ga] IIC Ex II (1) D [Ex ia Da] IIIC Ex II 3 G Ex nA nC ic IIC T4 Gc X [Ex ia Ga] IIC , [Ex ia Da] IIIC , Ex nA nC ic IIC T4 Gc X 2	

Description	Temperature transducer, intrinsically safe input
Standard configuration	Screw connection
Standard configuration	Push-in connection

Programming adapter for configuring modules with S-PORT interface

Ordering data		
Type	Order No.	Pcs./Pkt.
MACX MCR-EX-T-UIREL-UP	2865751	1
MACX MCR-EX-T-UIREL-UP-SP	2924799	1

Accessories		
IFS-USB-PROG-ADAPTER	2811271	1

Digital IN
NAMUR signal conditioner, Ex i

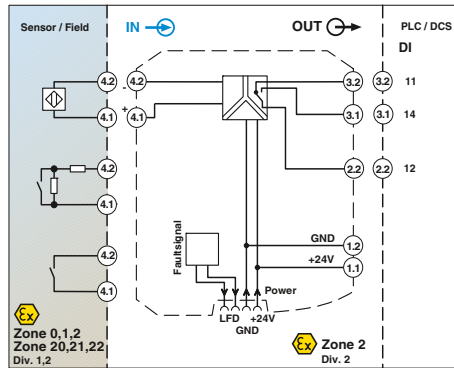
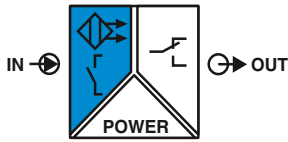

Signal output: PDT relay

EAC Ex
 EN 60947-5-6 Functional Safety
 Ex: Ex i
 Housing width 12.5 mm

NAMUR signal conditioner for intrinsically safe operation of proximity sensors and mechanical contacts installed in Ex areas.

- Input for NAMUR proximity sensors (EN 60947-5-6), floating contacts or contacts with resistance circuit, [Ex ia]
- Relay signal output (PDT)
- Reversible direction of action (operating current or closed-circuit current behavior)
- Line fault detection (LFD) can be activated and deactivated, error indicated by red flashing LED and de-excitation of the output relay
- Power supply and error indication possible via the DIN rail connector
- LED displays for indicating supply voltage, circuit state, and malfunctions to NAMUR NE 44
- 3-way electrical isolation
- Up to SIL 2 according to IEC 61508
- Installation in Zone 2 permitted

Notes:
Information about the supply and error evaluation module as well as about the DIN rail connectors and marking material can be found from page 174
Information about resistance circuits is given on page 176
Information on "Plug and play" connection using system cabling can be found from page 164

Input data
Input signal
No-load voltage
Switching points
Switching hysteresis
Line fault detection
Switching output
Contact type
Contact material
Max. switching voltage
Maximum switching capacity
Recommended minimum load
Mechanical service life
Switching behavior
Maximum switching frequency
General data
Supply voltage range
Current consumption
Power dissipation
Number of channels
Electrical isolation
Ambient temperature range
Humidity
Status indication
Inflammability class in acc. with UL 94
Housing material
Dimensions W/H/D
Screw connection solid/stranded/AWG
Push-in connection solid/stranded/AWG
EMC note
Safety data as per ATEX
Maximum output voltage U _o
Maximum output current I _o
Maximum output power P _o
Maximum voltage U _m
Conformance/Approvals
Conformance
ATEX
IECEx
UL, USA/Canada
SIL in accordance with IEC 61508

Technical data

NAMUR proximity sensors (EN 60947-5-6)
Floating switch contacts
Switch contacts with resistance circuit
~ 8 V DC
> 2.1 mA (conductive) / < 1.2 mA (blocking)
< 0.2 mA
Break 0.05 mA < I _{IN} < 0.35 mA
Short circuit 100 Ω < R _{Sensor} < 360 Ω
Relay output
1 PDT
AgSnO ₂ , hard gold-plated
250 V AC (2 A) / 120 V DC (0.2 A) / 30 V DC (2 A)
500 VA
5 V / 10 mA
10 ⁷ cycles
Can be inverted via slide switch
≤ 20 Hz (without load)
19.2 V DC ... 30 V DC (24 V DC -20%...+25%)
21 mA (24 V DC)
< 650 mW
1
375 V (Peak value in accordance with EN 60079-11)
300 V _{rms} (Rated insulation voltage (overvoltage category II; degree of pollution 2, safe isolation as per EN 61010-1))
2.5 kV (50 Hz, 1 min., test voltage)
300 V _{rms} (Rated insulation voltage (overvoltage category III; degree of pollution 2, safe isolation as per EN 61010-1))
2.5 kV (50 Hz, 1 min., test voltage)
-20 °C ... 60 °C (Any mounting position)
10 % ... 95 % (non-condensing)
Green LED (supply voltage)
Yellow LED (switching state)
Red LED (line fault)
V0
PA 66-FR
12.5 / 99 / 114.5 mm
0.2 ... 2.5 mm ² / 0.2 ... 2.5 mm ² / 24 - 14
0.2 ... 1.5 mm ² / 0.2 ... 1.5 mm ² / 24 - 16
Class A product, see page 605
9.6 V
10 mA
25 mW
253 V AC (125 V DC)
CE-compliant, additionally EN 61326
II (1) G [Ex ia Ga] IIC
II (1) D [Ex ia Da] IIIC
II 3 G Ex nA nC IIC T4 Gc X
[Ex ia Ga] IIC, [Ex ia Da] IIIC, Ex nA nC IIC T4 Gc
Class I Div 2; IS for Class I, II, III Div 1
2

Ordering data

Description	Type	Order No.	Pcs./Pkt.
NAMUR signal conditioner, 1-channel, input intrinsically safe, output: PDT contact			
Screw connection	MACX MCR-EX-SL-NAM-R	2865434	1
Push-in connection	MACX MCR-EX-SL-NAM-R-SP	2924045	1

Digital IN
NAMUR signal conditioner, Ex i

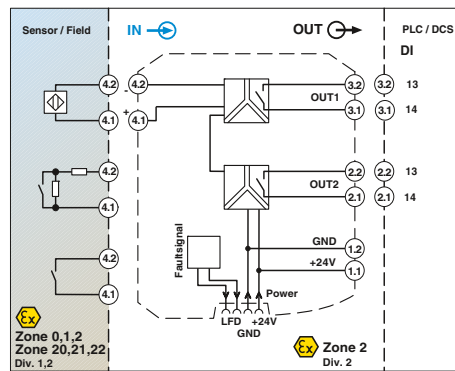
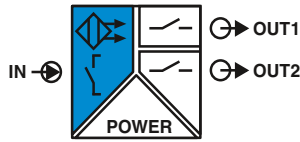

2 signal outputs: N/O contact relay

FRL DNV GL Functional Safety
 Ex: EAC Ex EEx Ex
 Housing width 12.5 mm

NAMUR signal conditioner for intrinsically safe operation of proximity sensors and mechanical contacts installed in Ex areas.

- Input for NAMUR proximity sensors (EN 60947-5-6), floating contacts or contacts with resistance circuit, [Ex ia]
- 2 relay signal outputs (N/O contact), output 2 can also be used as an error signal output
- Reversible direction of action (operating current or closed-circuit current behavior)
- Line fault detection (LFD) can be activated and deactivated, error indicated by red flashing LED and de-excitation of the output relay
- Power supply and error indication possible via the DIN rail connector
- LED displays for indicating supply voltage, circuit state, and malfunctions to NAMUR NE 44
- 4-way electrical isolation
- Up to SIL 2 according to IEC 61508
- Installation in Zone 2 permitted

Notes:

Information about the supply and error evaluation module as well as about the DIN rail connectors and marking material can be found from page 174
Information about resistance circuits is given on page 176
Information on "Plug and play" connection using system cabling can be found from page 164

Input data	
Input signal	
No-load voltage	
Switching points	
Switching hysteresis	
Line fault detection	
Switching output	
Contact type	
Contact material	
Max. switching voltage	
Maximum switching capacity	
Recommended minimum load	
Mechanical service life	
Switching behavior	
Maximum switching frequency	
General data	
Supply voltage range	
Current consumption	
Power dissipation	
Number of channels	
Electrical isolation	
Input/output	375 V (Peak value in accordance with EN 60079-11)
Input/supply, DIN rail connector	375 V (Peak value in accordance with EN 60079-11)
	300 V _{rms} (Rated insulation voltage (overvoltage category II; degree of pollution 2, safe isolation as per EN 61010-1))
Output 1/output 2/input, power supply, DIN rail connector	300 V _{rms} (Rated insulation voltage (overvoltage category III; degree of pollution 2, safe isolation as per EN 61010-1))
Output 1/output 2/input/power supply, DIN rail connector	2.5 kV (50 Hz, 1 min., test voltage)
Ambient temperature range	-20 °C ... 60 °C (Any mounting position)
Humidity	10 % ... 95 % (non-condensing)
Status indication	Green LED (supply voltage) Yellow LED (switching state) Red LED (line fault)
Inflammability class in acc. with UL 94	V0
Dimensions W/H/D	12.5 / 99 / 114.5 mm
Screw connection solid/stranded/AWG	0.2 ... 2.5 mm ² / 0.2 ... 2.5 mm ² / 24 - 14
Push-in connection solid/stranded/AWG	0.2 ... 1.5 mm ² / 0.2 ... 1.5 mm ² / 24 - 16
EMC note	Class A product, see page 605
Safety data as per ATEX	
Maximum output voltage U _o	9.6 V
Maximum output current I _o	10 mA
Maximum output power P _o	25 mW
Maximum voltage U _m	253 V AC (125 V DC)
Conformance/Approvals	
Conformance	
ATEX	
IECEX	
UL, USA/Canada	
SIL in accordance with IEC 61508	

Technical data

NAMUR proximity sensors (EN 60947-5-6)	
Floating switch contacts	
Switch contacts with resistance circuit	
~ 8 V DC	
> 2.1 mA (conductive) / < 1.2 mA (blocking)	
< 0.2 mA	
Break 0.05 mA < I _{IN} < 0.35 mA	
Short circuit 100 Ω < R _{Sensor} < 360 Ω	
Relay output	
2 N/O contacts	
AgSnO ₂ , hard gold-plated	
250 V AC (2 A) / 120 V DC (0.2 A) / 30 V DC (2 A)	
500 VA	
5 V / 10 mA	
10 ⁷ cycles	
Can be inverted via slide switch	
≤ 20 Hz (without load)	
19.2 V DC ... 30 V DC (24 V DC -20%...+25%)	
30 mA (24 V DC)	
< 950 mW	
1	
Input/output	375 V (Peak value in accordance with EN 60079-11)
Input/supply, DIN rail connector	375 V (Peak value in accordance with EN 60079-11)
	300 V _{rms} (Rated insulation voltage (overvoltage category II; degree of pollution 2, safe isolation as per EN 61010-1))
Output 1/output 2/input, power supply, DIN rail connector	300 V _{rms} (Rated insulation voltage (overvoltage category III; degree of pollution 2, safe isolation as per EN 61010-1))
Output 1/output 2/input/power supply, DIN rail connector	2.5 kV (50 Hz, 1 min., test voltage)
Ambient temperature range	-20 °C ... 60 °C (Any mounting position)
Humidity	10 % ... 95 % (non-condensing)
Status indication	Green LED (supply voltage) Yellow LED (switching state) Red LED (line fault)
Inflammability class in acc. with UL 94	V0
Dimensions W/H/D	12.5 / 99 / 114.5 mm
Screw connection solid/stranded/AWG	0.2 ... 2.5 mm ² / 0.2 ... 2.5 mm ² / 24 - 14
Push-in connection solid/stranded/AWG	0.2 ... 1.5 mm ² / 0.2 ... 1.5 mm ² / 24 - 16
EMC note	Class A product, see page 605
Safety data as per ATEX	
Maximum output voltage U _o	9.6 V
Maximum output current I _o	10 mA
Maximum output power P _o	25 mW
Maximum voltage U _m	253 V AC (125 V DC)
Conformance/Approvals	
Conformance	
ATEX	
IECEX	
UL, USA/Canada	
SIL in accordance with IEC 61508	

Ordering data

Description	NAMUR signal conditioner, 1-channel, input intrinsically safe, output: 2 N/O contacts
	Screw connection
	Push-in connection

Type	Order No.	Pcs./ Pkt.
MACX MCR-EX-SL-NAM-2RO	2865450	1
MACX MCR-EX-SL-NAM-2RO-SP	2924061	1

Digital IN
NAMUR signal conditioner, Ex i

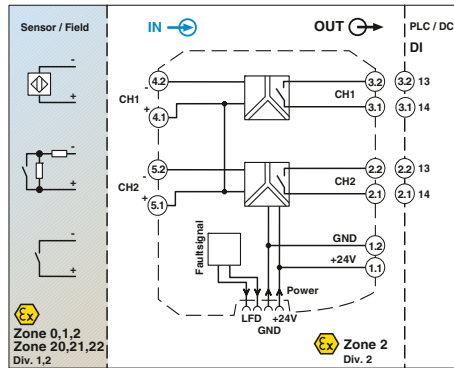
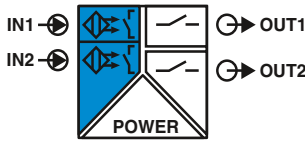

2-channel, signal output: N/O contact relay

EAC Ex
 UL
 IEC 61508
 Housing width 12.5 mm

NAMUR signal conditioner for intrinsically safe operation of proximity sensors and mechanical contacts installed in Ex areas.

- 2-channel
- Input for NAMUR proximity sensors (EN 60947-5-6), floating contacts or contacts with resistance circuit, [Ex ia]
- Relay signal output (N/O contact)
- Reversible direction of action (operating current or closed-circuit current behavior)
- Line fault detection (LFD) can be activated and deactivated, error indicated by red flashing LED and de-excitation of the output relay
- Power supply and error indication possible via the DIN rail connector
- LED displays for indicating supply voltage, circuit state, and malfunctions to NAMUR NE 44
- 3-way electrical isolation
- Up to SIL 2 according to IEC 61508
- Installation in Zone 2 permitted

Input data
Input signal

No-load voltage
Switching points
Switching hysteresis
Line fault detection

Switching output

Contact type
Contact material
Max. switching voltage
Maximum switching capacity
Recommended minimum load
Mechanical service life
Switching behavior
Maximum switching frequency

General data

Supply voltage range
Current consumption
Power dissipation
Number of channels
Electrical isolation

Ambient temperature range
Humidity
Status indication

Inflammability class in acc. with UL 94
Dimensions W/H/D
Screw connection solid/stranded/AWG
Push-in connection solid/stranded/AWG
EMC note

Safety data as per ATEX

Maximum output voltage U_o
Maximum output current I_o
Maximum output power P_o
Maximum voltage U_m
Conformance/Approvals
Conformance
ATEX

IECEx
UL, USA/Canada
SIL in accordance with IEC 61508

Input/output
Input/supply, DIN rail connector

Output 1/output 2/input, power supply, DIN rail connector

Output 1/output 2/input/power supply, DIN rail connector

Technical data

NAMUR proximity sensors (EN 60947-5-6)
Floating switch contacts
Switch contacts with resistance circuit
~ 8 V DC
> 2.1 mA (conductive) / < 1.2 mA (blocking)
< 0.2 mA
Break 0.05 mA < IIN < 0.35 mA
Short circuit 100 Ω < RSensor < 360 Ω
Relay output
1 N/O contact per channel
AgSnO₂, hard gold-plated
250 V AC (2 A) / 120 V DC (0.2 A) / 30 V DC (2 A)
500 VA
5 V / 10 mA
10⁷ cycles
Can be inverted via slide switch
≤ 20 Hz (without load)

19.2 V DC ... 30 V DC (24 V DC -20%...+25%)
35 mA (24 V DC)
< 1 W
2

375 V (Peak value in accordance with EN 60079-11)
375 V (Peak value in accordance with EN 60079-11)
300 V_{rms} (Rated insulation voltage (overvoltage category II; degree of pollution 2, safe isolation as per EN 61010-1))

300 V_{rms} (Rated insulation voltage (overvoltage category III; degree of pollution 2, safe isolation as per EN 61010-1))

2.5 kV (50 Hz, 1 min., test voltage)

-20 °C ... 60 °C (Any mounting position)

5% ... 95% (non-condensing)

Green LED (supply voltage)

Yellow LED (switching state)

Red LED (line fault)

V0

12.5 / 99 / 114.5 mm

0.2 ... 2.5 mm² / 0.2 ... 2.5 mm² / 24 - 14

0.2 ... 1.5 mm² / 0.2 ... 1.5 mm² / 24 - 16

Class A product, see page 605

9.6 V

10 mA

25 mW

253 V AC (125 V DC)

CE-compliant, additionally EN 61326

II (1) G [Ex ia Ga] IIC

II (1) D [Ex ia Da] IIIC

II 3 G Ex nA nC IIC T4 Gc X

[Ex ia Ga] IIC, [Ex ia Da] IIIC, Ex nA nC IIC T4 Gc

Class I Div 2; IS for Class I, II, III Div 1

2

Ordering data

Description

NAMUR signal conditioner, 2-channel, input intrinsically safe, output: N/O contact

Screw connection
Push-in connection

Type

MACX MCR-EX-SL-2NAM-RO
MACX MCR-EX-SL-2NAM-RO-SP

Order No.

2865476
2924087

Pcs./Pkt.

1
1

Digital IN
NAMUR signal conditioner, Ex i

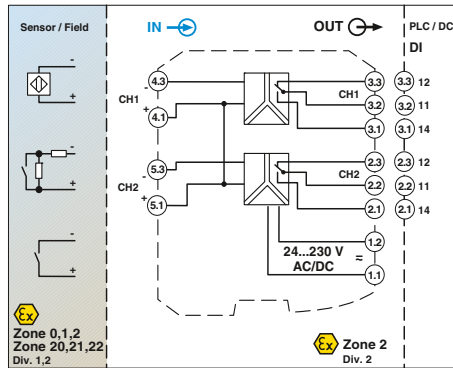
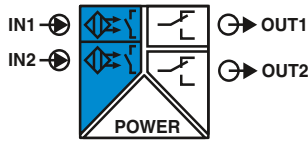

2-channel, signal output: PDT relay, wide-range power supply

Functional Safety
Ex: EAC Ex
Housing width 17.5 mm

NAMUR signal conditioner for intrinsically safe operation of proximity sensors and mechanical contacts installed in Ex areas.

- 2-channel
- Input for NAMUR proximity sensors (EN 60947-5-6), floating contacts or contacts with resistance circuit, [Ex ia]
- Relay signal output (PDT)
- Reversible direction of action (operating current or closed-circuit current behavior)
- Line fault detection (LFD) can be activated and deactivated, error indicated by red flashing LED and de-excitation of the output relay
- Wide-range power supply of 19.2 to 253 V AC/DC
- LED displays for indicating supply voltage, circuit state, and malfunctions to NAMUR NE 44
- 3-way electrical isolation
- Up to SIL 2 according to IEC 61508
- Installation in Zone 2 permitted

Notes:
Information on resistance circuits and marking material can be found on page 176

Input data
Input signal

No-load voltage
Switching points
Switching hysteresis
Line fault detection

Switching output

Contact type
Contact material
Max. switching voltage
Maximum switching capacity
Recommended minimum load
Mechanical service life
Switching behavior
Maximum switching frequency

General data

Supply voltage range

Current consumption
Power dissipation
Electrical isolation

Input/output
Input/power supply

Output 1/output 2/input, power supply

Ambient temperature range
Humidity
Inflammability class in acc. with UL 94
Housing material
Dimensions W/H/D
Screw connection solid/stranded/AWG
Push-in connection solid/stranded/AWG
EMC note

Safety data as per ATEX

Maximum output voltage U_o
Maximum output current I_o
Maximum output power P_o
Maximum voltage U_m

Conformance/Approvals

Conformance
ATEX

IECEX
UL, USA/Canada

SIL in accordance with IEC 61508

Technical data

NAMUR proximity sensors (EN 60947-5-6)
open circuit switch contacts
Switch contacts with resistance circuit
~ 8 V DC
> 2.1 mA (conductive) / < 1.2 mA (blocking)
approx. 0.2 mA
Break 0.05 mA < I_{IN} < 0.35 mA
Short circuit 100 Ω < R_{Sensor} < 360 Ω

Relay output

1 PDT per channel
AgSnO₂, hard gold-plated
250 V AC (2 A, 60 Hz) / 120 V DC (0.2 A) / 30 V DC (2 A)
500 VA
5 V / 10 mA
10⁷ cycles
can be inverted using DIP switch
≤ 20 Hz (Load-dependent)

24 V ... 230 V AC/DC (-20 % ... +10 %, 50 Hz ... 60 Hz)

< 80 mA ; < 42 mA (24 V DC)
≤ 1.3 W

375 V (Peak value in accordance with EN 60079-11)
375 V (Peak value in accordance with EN 60079-11)
300 V_{rms} (Rated insulation voltage (overvoltage category II; degree of pollution 2, safe isolation as per EN 61010-1))
2.5 kV AC (50 Hz, 1 min., test voltage)

300 V_{rms} (Rated insulation voltage (overvoltage category III; degree of pollution 2, safe isolation as per EN 61010-1))
2.5 kV (50 Hz, 1 min., test voltage)

-20 °C ... 60 °C
10 % ... 95 % (non-condensing)

V0
PA 66-FR
17.5 / 99 / 114.5 mm
0.2 ... 2.5 mm² / 0.2 ... 2.5 mm² / 24 - 14
0.2 ... 1.5 mm² / 0.2 ... 1.5 mm² / 24 - 16
Class A product, see page 605

9.56 V
10.3 mA
25 mW
253 V AC/DC (Supply terminals)
250 V AC (Output terminals)
120 V DC (Output terminals)

CE-compliant, additionally EN 61326
II (1) G [Ex ia Ga] IIC
II (1) D [Ex ia Da] IIIC
II 3(1) G Ex nA nC [ia Ga] IIC T4 Gc X
[Ex ia Ga] IIC, [Ex ia Da] IIIC, Ex nA nC [ia Ga] IIC T4 Gc
Class I Div 2; IS for Class I, II, III Div 1
2

Ordering data

Description

NAMUR signal conditioner, 2-channel, input intrinsically safe, output: changeover contact

Screw connection
Push-in connection

Type

Type	Order No.	Pcs./Pkt.
MACX MCR-EX-SL-2NAM-R-UP	2865984	1
MACX MCR-EX-SL-2NAM-R-UP-SP	2924249	1

Digital IN
NAMUR signal conditioner, Ex i

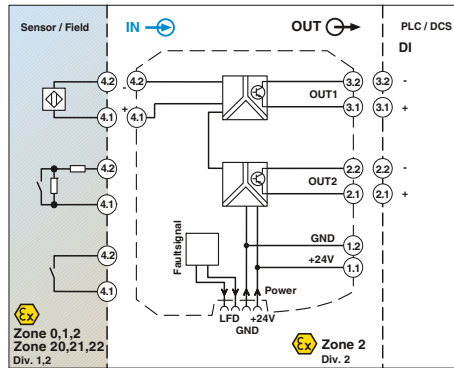
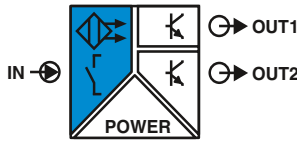

2 signal outputs: transistor (passive)

UL DNV GL Functional Safety
Ex: Ex EAC Ex
Housing width 12.5 mm

Technical data

NAMUR signal conditioner for intrinsically safe operation of proximity sensors and mechanical contacts installed in Ex areas.

- Input for NAMUR proximity sensors (EN 60947-5-6), floating contacts or contacts with resistance circuit, [Ex ia]
- 2 signal outputs transistor (passive), up to 5 kHz
- Signal output 2 can also be used as a fault signaling output
- Reversible direction of action (operating current or closed-circuit current behavior)
- Line fault detection (LFD) can be activated and deactivated, error indicated by red flashing LED and blocking the transistor output
- Power supply and error indication possible via the DIN rail connector
- LED displays for indicating supply voltage, circuit state, and malfunctions to NAMUR NE 44
- 4-way electrical isolation
- Up to SIL 2 according to IEC 61508
- Installation in Zone 2 permitted

Input data	
Input signal	
No-load voltage	
Switching points	
Line fault detection	
Switching output	
Max. switching voltage	
Maximum switching current	
Drop (ΔU)	
Switching behavior	
Maximum switching frequency	
General data	
Supply voltage range	
Current consumption	
Power dissipation	
Number of channels	
Electrical isolation	
Input/output	375 V (Peak value in accordance with EN 60079-11)
Input/output/supply, DIN rail connector	300 V _{rms} (Rated insulation voltage (overvoltage category II; degree of pollution 2, safe isolation as per EN 61010-1)) 2.5 kV (50 Hz, 1 min., test voltage)
Input/supply, DIN rail connector	375 V (Peak value in accordance with EN 60079-11)
Output 1/output 2	50 V _{rms} (Rated insulation voltage (overvoltage category II; degree of pollution 2, basic insulation as per EN 61010-1)) 1 kV (50 Hz, 1 min., test voltage)
Ambient temperature range	-20 °C ... 60 °C (Any mounting position)
Humidity	10 % ... 95 % (non-condensing)
Status indication	Green LED (supply voltage) Yellow LED (switching state) Red LED (line fault)
Inflammability class in acc. with UL 94	V0
Housing material	PA 66-FR
Dimensions W/H/D	12.5 / 99 / 114.5 mm
Screw connection solid/stranded/AWG	0.2 ... 2.5 mm ² / 0.2 ... 2.5 mm ² / 24 - 14
Push-in connection solid/stranded/AWG	0.2 ... 1.5 mm ² / 0.2 ... 1.5 mm ² / 24 - 16
EMC note	Class A product, see page 605
Safety data as per ATEX	
Maximum output voltage U _o	
Maximum output current I _o	
Maximum output power P _o	
Maximum voltage U _m	
Conformance/Approvals	
Conformance	
ATEX	
IECEX	
UL, USA/Canada	
SIL in accordance with IEC 61508	

Technical data		
NAMUR proximity sensors (EN 60947-5-6)		
Floating switch contacts		
Switch contacts with resistance circuit		
~ 8 V DC		
> 2.1 mA (conductive) / < 1.2 mA (blocking)		
Break 0.05 mA < I _{IN} < 0.35 mA		
Short circuit 100 Ω < R _{Sensor} < 360 Ω		
2 transistor outputs, passive		
30 V DC		
50 mA (short-circuit-proof)		
< 1.4 V		
can be inverted using DIP switch		
≤ 5 kHz		
19.2 V DC ... 30 V DC (24 V DC -20%...+25%)		
< 28 mA (24 V DC)		
≤ 800 mW		
1		
Input/output	375 V (Peak value in accordance with EN 60079-11)	
Input/output/supply, DIN rail connector	300 V _{rms} (Rated insulation voltage (overvoltage category II; degree of pollution 2, safe isolation as per EN 61010-1))	2.5 kV (50 Hz, 1 min., test voltage)
Input/supply, DIN rail connector	375 V (Peak value in accordance with EN 60079-11)	
Output 1/output 2	50 V _{rms} (Rated insulation voltage (overvoltage category II; degree of pollution 2, basic insulation as per EN 61010-1))	1 kV (50 Hz, 1 min., test voltage)
Ambient temperature range	-20 °C ... 60 °C (Any mounting position)	
Humidity	10 % ... 95 % (non-condensing)	
Status indication	Green LED (supply voltage) Yellow LED (switching state) Red LED (line fault)	
Inflammability class in acc. with UL 94	V0	
Housing material	PA 66-FR	
Dimensions W/H/D	12.5 / 99 / 114.5 mm	
Screw connection solid/stranded/AWG	0.2 ... 2.5 mm ² / 0.2 ... 2.5 mm ² / 24 - 14	
Push-in connection solid/stranded/AWG	0.2 ... 1.5 mm ² / 0.2 ... 1.5 mm ² / 24 - 16	
EMC note	Class A product, see page 605	
Safety data as per ATEX		
Maximum output voltage U _o		
10 mA		
25 mW		
253 V AC (125 V DC)		
Conformance/Approvals		
Conformance		
ATEX		
IECEX		
UL, USA/Canada		
SIL in accordance with IEC 61508		

Notes:
Information about the supply and error evaluation module as well as about the DIN rail connectors and marking material can be found on page 174
Information about resistance circuits is given on page 176
Information on "Plug and play" connection using system cabling can be found on page 164

Ordering data

Description	Type	Order No.	Pcs./Pkt.
NAMUR signal conditioner, input intrinsically safe, output: transistor, passive	Screw connection	MACX MCR-EX-SL-NAM-2T	2865463
	Push-in connection	MACX MCR-EX-SL-NAM-2T-SP	2924074

Digital IN
NAMUR signal conditioner, Ex i

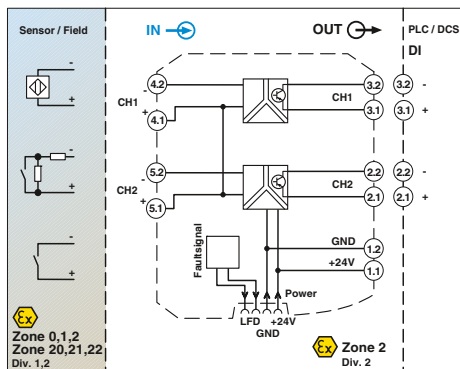
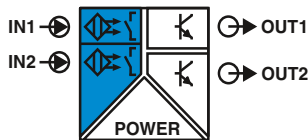

2-channel, signal output transistor (passive)

Functional Safety
Ex: Ex EAC Ex
Housing width 12.5 mm

NAMUR signal conditioner for intrinsically safe operation of proximity sensors and mechanical contacts installed in Ex areas.

- 2-channel
- Input for NAMUR proximity sensors (EN 60947-5-6), floating contacts or contacts with resistance circuit, [Ex ia]
- Signal output transistor (passive), up to 5 kHz
- Reversible direction of action (operating current or closed-circuit current behavior)
- Line fault detection (LFD) can be activated and deactivated, error indicated by red flashing LED and blocking the transistor output
- Power supply and error indication possible via the DIN rail connector
- LED displays for indicating supply voltage, circuit state, and malfunctions to NAMUR NE 44
- 3-way electrical isolation
- Up to SIL 2 according to IEC 61508
- Installation in Zone 2 permitted

Notes:
Information about the supply and error evaluation module as well as about the DIN rail connectors and marking material can be found from page 174
Information about resistance circuits is given on page 176
Information on "Plug and play" connection using system cabling can be found from page 164

Input data
Input signal
No-load voltage
Switching points
Line fault detection
Switching output
Max. switching voltage
Maximum switching current
Drop (ΔU)
Switching behavior
Maximum switching frequency
General data
Supply voltage range
Current consumption
Power dissipation
Number of channels
Electrical isolation
Input/output Input/output/supply, DIN rail connector
Input/supply, DIN rail connector Output 1/output 2
Ambient temperature range
Humidity
Status indication
Inflammability class in acc. with UL 94
Housing material
Dimensions W/H/D
Screw connection solid/stranded/AWG
Push-in connection solid/stranded/AWG
EMC note
Safety data as per ATEX
Maximum output voltage U_o
Maximum output current I_o
Maximum output power P_o
Maximum voltage U_m
Conformance/Approvals
Conformance
ATEX
IECEX
UL, USA/Canada
SIL in accordance with IEC 61508

Technical data

NAMUR proximity sensors (EN 60947-5-6)
Floating switch contacts
Switch contacts with resistance circuit
~ 8 V DC
> 2.1 mA (conductive) / < 1.2 mA (blocking)
Break 0.05 mA < I_{IN} < 0.35 mA
Short circuit 100 Ω < R_{Sensor} < 360 Ω
1 transistor output, passive (per channel)
30 V DC
50 mA (short-circuit-proof)
< 1.4 V
can be inverted using DIP switch
\leq 5 kHz
General data
19.2 V DC ... 30 V DC (24 V DC -20%...+25%)
< 34 mA (24 V DC)
\leq 1000 mW
2
Input/output
375 V (Peak value in accordance with EN 60079-11)
300 V_{rms} (Rated insulation voltage (overvoltage category II; degree of pollution 2, safe isolation as per EN 61010-1))
2.5 kV (50 Hz, 1 min., test voltage)
Input/supply, DIN rail connector
375 V (Peak value in accordance with EN 60079-11)
50 V_{rms} (Rated insulation voltage (overvoltage category II; degree of pollution 2, basic insulation as per EN 61010-1))
1 kV (50 Hz, 1 min., test voltage)
-20 °C ... 60 °C (Any mounting position)
10 % ... 95 % (non-condensing)
Green LED (supply voltage)
Yellow LED (switching state)
Red LED (line fault)
V0
PA 66-FR
12.5 / 99 / 114.5 mm
0.2 ... 2.5 mm ² / 0.2 ... 2.5 mm ² / 24 - 14
0.2 ... 1.5 mm ² / 0.2 ... 1.5 mm ² / 24 - 16
Class A product, see page 605
9.6 V
10 mA
25 mW
253 V AC (125 V DC)
CE-compliant, additionally EN 61326
Ex II (1) G [Ex ia Ga] IIC
Ex II (1) D [Ex ia Da] IIIC
Ex II 3 G Ex nA IIC T4 Gc X
[Ex ia Ga] IIC, [Ex ia Da] IIIC, Ex nA IIC T4 Gc
Class I Div 2; IS for Class I, II, III Div 1
2

Ordering data

Description	Type	Order No.	Pcs./ Pkt.
NAMUR signal conditioner, 2-channel, input intrinsically safe, output: transistor, passive	MACX MCR-EX-SL-2NAM-T	2865489	1
Screw connection	MACX MCR-EX-SL-2NAM-T-SP	2924090	1
Push-in connection			

Digital IN
NAMUR signal conditioner, Ex i

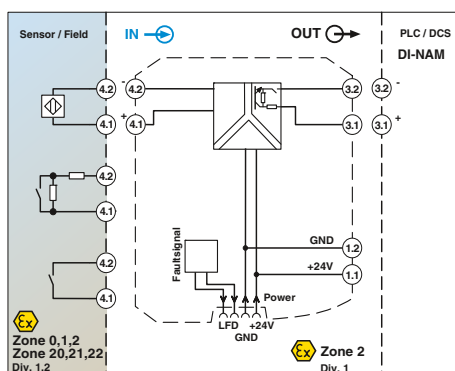
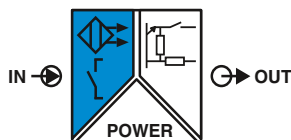

With line fault transparency



Ex: EAC Ex
Housing width 12.5 mm

NAMUR signal conditioners for the intrinsically safe operation of proximity sensors or mechanical contacts installed in the Ex area.

- Input for NAMUR proximity sensors (EN 60947-5-6), floating contacts or contacts with resistance circuit, [Ex ia]
- Signal output with resistive behavior (transistor)
- Signal output with line fault transparency: line fault indicated directly via output to PLC or PCS. The output responds in accordance with EN 60947-5-6.
- Up to 5 kHz
- Direction of operation can be selected
- Line fault detection can be activated and deactivated
- Power supply and error indication possible via the DIN rail connector
- LED indicators for supply voltage, status, and fault according to NAMUR NE 44
- Plug-in screw or Push-in connection technology
- Safe 3-way electrical isolation
- Up to SIL 2 according to IEC 61508
- Installation in Zone 2 permitted

Notes:
Information on the supply and error evaluation module, DIN rail connectors, system cabling, and marking material can be found from page 174
Information about resistance circuits is given on page 176

Input data	
Input signal	
No-load voltage	
Switching points	
Line fault detection	
Switching output	
Switching voltage	
Switching frequency	
Impedance 0-signal	
Impedance 1-signal	
Impedance fault	
Switching behavior	
General data	
Supply voltage range	
Current draw	
Power dissipation	
Electrical isolation	
Input/output	375 V (Peak value in accordance with EN 60079-11)
Input/output/supply, DIN rail connector	300 V _{rms} (Rated insulation voltage (overvoltage category II; degree of pollution 2, safe isolation as per EN 61010-1)) 2.5 kV (50 Hz, 1 min., test voltage)
Input/supply, DIN rail connector	375 V (Peak value in accordance with EN 60079-11)
Ambient temperature range	-20 °C ... 60 °C (Any mounting position)
Humidity	10 % ... 95 % (non-condensing)
Status indication	Green LED (supply voltage) Yellow LED (switching state) Red LED (line fault) V0
Inflammability class in acc. with UL 94	PA 66-FR
Housing material	12.5 / 99 / 114.5 mm
Dimensions W/H/D	0.2 ... 2.5 mm ² / 0.2 ... 2.5 mm ² / 24 - 14
Screw connection solid/stranded/AWG	0.2 ... 1.5 mm ² / 0.2 ... 1.5 mm ² / 24 - 16
Push-in connection solid/stranded/AWG	Class A product, see page 605
EMC note	
Safety data as per ATEX	
Maximum output voltage U _o	9.6 V
Maximum output current I _o	10 mA
Maximum output power P _o	25 mW
Maximum voltage U _m	253 V AC/DC
Conformance/Approvals	
Conformance	CE-compliant, additionally EN 61326
ATEX	[Ex ia Ga] IIC , [Ex ia Da] IIIC , Ex nA IIC T4 Gc X
IECEX	[Ex ia Ga] IIC , [Ex ia Da] IIIC , Ex nA IIC T4 Gc
SIL in accordance with IEC 61508	2

Technical data

NAMUR proximity sensors (EN 60947-5-6)
open circuit switch contacts
Switch contacts with resistance circuit
8 V DC ±10 %
> 2.1 mA (conductive) / < 1.2 mA (blocking)
Break 0.05 mA < I _{IN} < 0.35 mA
Short circuit 100 Ω < R _{Sensor} < 360 Ω
Resistive (transistor, passive)
8.2 V DC ±10 % (according to EN 60947-5-6)
≤ 5 kHz (Ohmic load)
11 kΩ ±5 %
1.4 kΩ ±5 %
> 100 kΩ
can be inverted using DIP switch
9.6 V DC ... 30 V DC (12 V DC ... 24 V DC (-20 % ... +25 %))
25 mA (24 V DC)
< 0.6 W
375 V (Peak value in accordance with EN 60079-11)
300 V _{rms} (Rated insulation voltage (overvoltage category II; degree of pollution 2, safe isolation as per EN 61010-1))
2.5 kV (50 Hz, 1 min., test voltage)
375 V (Peak value in accordance with EN 60079-11)
-20 °C ... 60 °C (Any mounting position)
10 % ... 95 % (non-condensing)
Green LED (supply voltage)
Yellow LED (switching state)
Red LED (line fault)
V0
PA 66-FR
12.5 / 99 / 114.5 mm
0.2 ... 2.5 mm ² / 0.2 ... 2.5 mm ² / 24 - 14
0.2 ... 1.5 mm ² / 0.2 ... 1.5 mm ² / 24 - 16
Class A product, see page 605
9.6 V
10 mA
25 mW
253 V AC/DC
CE-compliant, additionally EN 61326
[Ex ia Ga] IIC , [Ex ia Da] IIIC , Ex nA IIC T4 Gc X
[Ex ia Ga] IIC , [Ex ia Da] IIIC , Ex nA IIC T4 Gc
2

Ordering data

Description	Type	Order No.	Pcs./Pkt.
NAMUR signal conditioner , intrinsically safe input, output with line fault transparency			
Screw connection	MACX MCR-EX-SL-NAM-NAM	2866006	1
Push-in connection	MACX MCR-EX-SL-NAM-NAM-SP	2924883	1
Specifically for Yokogawa systems			
Screw connection	MACX MCR-EX-SL-NAM-YO	2905723	1
Push-in connection	MACX MCR-EX-SL-NAM-YO-SP	2905724	1
Specifically for Honeywell systems			
Screw connection	MACX MCR-EX-SL-NAM-HO	2907404	1
Push-in connection	MACX MCR-EX-SL-NAM-HO-SP	2907405	1

Ex i signal conditioners with SIL functional safety – MACX Analog Ex

Solenoid drivers for controlling solenoid valves

In order to control intrinsically safe Ex i solenoid valves, you have to have an intrinsically safe control circuit. This is provided by the solenoid drivers that are available from Phoenix Contact.

The following must be taken into account when dimensioning your intrinsically safe control circuit:

- Valve
- Cable with corresponding resistance
- Solenoid driver

As a result, it may be the case that not all valves are compatible with the solenoid drivers.

Below is an extract from a table showing possible combinations of valves and solenoid drivers.

A complete and updated list (along with details of the technical data for suitable valves, the maximum cable lengths, and the maximum cable resistances of the individual combinations) can be found on the Internet at: phoenixcontact.net/products

Example of a circuit

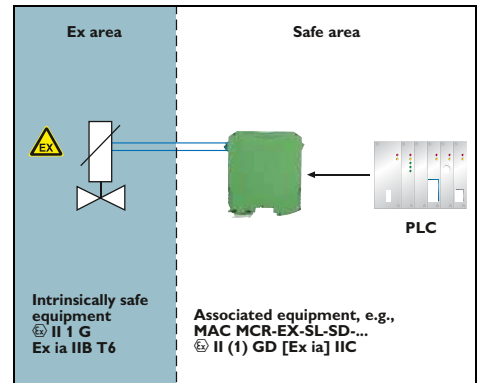

Valves overview

Manufacturer	Type designation	Ex certificate	Condition	MACX Analog Ex solenoid drivers			
				MACX MCR-EX-SL-SD-21-25-LP	MACX MCR-EX-SL-SD-21-40-LP	MACX MCR-EX-SL-SD-24-48-LP	MACX MCR-EX-SL-SD-21-60-LP
ASCO	Coil 195	LCIE 08 ATEX 6083			✓	✓	
	Coil 302 (12 V)	INERIS 03 ATEX 0249X				✓	✓
	Coil 302 (24 V)	INERIS 03 ATEX 0249X					✓
Bürkert	Coil AC 10, standard	PTB 01 ATEX 2101			✓	✓	
	Coil AC 10, high-resistance	PTB 01 ATEX 2101			✓	✓	
	Coil AC 21, standard	PTB 01 ATEX 2175	700 mW / 65°C		✓	✓	
	Coil AC 21, high-resistance	PTB 01 ATEX 2175	700 mW / 65°C		✓	✓	
	Coil AC 21, standard	PTB 01 ATEX 2175	900 mW / 45°C		✓	✓	
	Coil AC 21, high-resistance	PTB 01 ATEX 2175	900 mW / 45°C		✓	✓	
	Coil AC 21, standard	PTB 01 ATEX 2175	900 mW / 60°C		✓	✓	
	Coil AC 21, high-resistance	PTB 01 ATEX 2175	900 mW / 60°C		✓	✓	
	Coil G1 642735, standard		600 mW / 50°C		✓		
	Coil G1 642735, high-resistance		600 mW / 50°C		✓		
FESTO	Coil MFH...IA-SA-EX GBXE022AIAD03	PTB 03 ATEX 2097				✓	✓
	Coil (J)MFH...BIA-SA-EX GBXE022AIAD03	PTB 03 ATEX 2097				✓	✓
	Coil 2050	PTB 07 ATEX 2019			✓	✓	✓
	Coil 2051	PTB 07 ATEX 2019			✓	✓	✓
	Coil 2052	PTB 07 ATEX 2019			✓	✓	✓
	Coil 2053	PTB 07 ATEX 2019			✓	✓	✓
	Coil 2085	PTB 06 ATEX 2001 U		✓		✓	
	Coil 2086	PTB 06 ATEX 2001 U		✓	✓	✓	✓
	Coil 3039	PTB 03 ATEX 2134				✓	✓
	Coil 2003	PTB 04 ATEX 2010				✓	✓
Hörbiger	Piezo P8 38x RF-Nx-SPN65	DMT 01 ATEX E026X	30 V type	✓	✓		
	Piezo P20 381RF-NG-CPN61	DMT 01 ATEX E025X	30 V type	✓	✓		
Parker	Coil VZ07 488650.01	LCIE 02 ATEX 6024X			✓	✓	
	Coil VZ33 494035.10	LCIE 02 ATEX 6024X			✓	✓	
	Coil VZ08 488660.01	LCIE 02 ATEX 6024X			✓	✓	
	Coil VZ09 488670.01	LCIE 02 ATEX 6024X			✓	✓	
	Coil VZ95 482160.01	LCIE 02 ATEX 6024X	EEx ia IIB T6		✓	✓	✓
	Coil VZ23 482870.01	LCIE 02 ATEX 6024X			✓	✓	
Samson	Coil 3701-11 (6 V)	PTB 02 ATEX 2178		✓	✓	✓	
	Coil 3701-12 (12 V)	PTB 02 ATEX 2178		✓	✓	✓	
	Coil 3701-13 (24 V)	PTB 02 ATEX 2178		✓	✓	✓	
	Coil 3963-11 (6 V)	PTB 01 ATEX 2085		✓	✓	✓	
	Coil 3963-12 (12 V)	PTB 01 ATEX 2085		✓	✓	✓	
	Coil 3963-13 (24 V)	PTB 01 ATEX 2085		✓	✓	✓	
	Coil 3964-11 (6 V)	PTB 02 ATEX 2047		✓	✓	✓	
	Coil 3964-12 (12 V)	PTB 02 ATEX 2047		✓	✓	✓	
	Coil 3964-13 (24 V)	PTB 02 ATEX 2047		✓	✓	✓	
	Coil 3965-11 (6 V)	PTB 05 ATEX 2044X		✓	✓	✓	
	Coil 3965-12 (12 V)	PTB 05 ATEX 2044X		✓	✓	✓	
	Coil 3965-13 (24 V)	PTB 05 ATEX 2044X		✓	✓	✓	
	Coil 3967-11 (6 V)	PTB 06 ATEX 2027		✓	✓	✓	
	Coil 3967-12 (12 V)	PTB 06 ATEX 2027		✓	✓	✓	
	Coil 3967-13 (24 V)	PTB 06 ATEX 2027		✓	✓	✓	
Seitz	Pilot valve PV 12F73 Ci oH	PTB 99 ATEX 2146		✓	✓	✓	
	Pilot valve PV 12F73 Xi oH	PTB 00 ATEX 2030		✓	✓	✓	
	Pilot valve PV 12F73 Xi oH-2	PTB 00 ATEX 2030		✓	✓	✓	
	Solenoid 11 G 52	PTB 01 ATEX 2020		✓	✓	✓	

Digital OUT
Solenoid driver, Ex i

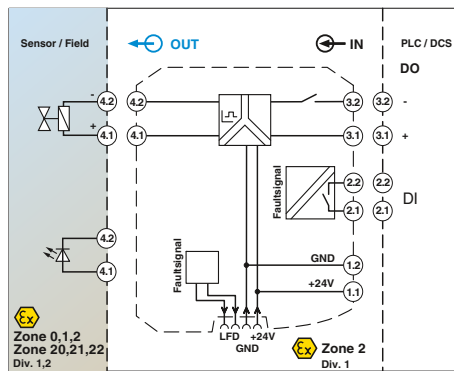
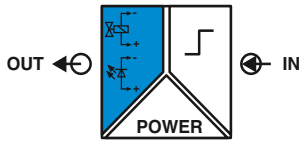

**Current limitation 48 mA,
with line fault detection**

Functional Safety
Ex: EAC Ex
Housing width 12.5 mm

Solenoid driver for the intrinsically safe control of Ex i solenoid valves, alarm transmitters or indicators installed in the Ex area.

- Input: logic (low/high signal)
- Output: 48 mA current limitation at 9.5 V, [Ex ia]
- Line fault detection (can be activated and deactivated)
 - Directly via signal channel
 - Or via switching output
- Transparent for test pulses
- Power supply and error indication possible via the DIN rail connector
- LED indicators for supply voltage, status, and fault according to NAMUR NE 44
- Plug-in screw or Push-in connection technology
- Safe 3-way electrical isolation
- Up to SIL 2 according to IEC 61508
- Installation in Zone 2 permitted

Notes:
Information on the supply and error evaluation module, DIN rail connectors, system cabling, and marking material can be found from page 174

Input data	Switching level 0 signal ("L") Switching level 1 signal ("H") Current input signal Input impedance in the event of a line fault at the output
Transparent for test pulses	Yes
Output data	Output voltage Current limitation No-load voltage Internal resistance Immunity to short-circuiting Response time t_A Line fault detection
Error message output	Switch contact Max. switching voltage Maximum switching current Short-circuit-proof
General data	Supply voltage range Current draw Power dissipation Electrical isolation
Ambient temperature range	-20 °C ... 60 °C
Humidity	10 % ... 95 % (non-condensing)
Status indication	Green LED (supply voltage) Yellow LED (switching state) Red LED (line fault)
Degree of protection	IP20
Inflammability class in acc. with UL 94	V0
Housing material	PA 66-FR
Dimensions W/H/D	12.5 / 112.5 / 114.5 mm
Screw connection solid/stranded/AWG	0.2 ... 2.5 mm ² / 0.2 ... 2.5 mm ² / 24 - 14
Push-in connection solid/stranded/AWG	0.2 ... 1.5 mm ² / 0.2 ... 1.5 mm ² / 24 - 16
EMC note	Class A product, see page 605
Safety data as per ATEX	Maximum output voltage U_o Maximum output current I_o Maximum output power P_o Maximum voltage U_m
Conformance/Approvals	CE-compliant, additionally EN 61326 [Ex ia Ga] IIC/IIB [Ex ia Da] IIIC [Ex ia Ga] IIC T4 Gc X [Ex ia Ga] IIC/IIB, [Ex ia Da] IIIC, Ex nA [ia Ga] IIC T4 Gc 3
IECEX	
SIL in accordance with IEC 61508	

Technical data

0 V DC ... 5 V DC (Open)
15 V DC ... 30 V DC
< 12 mA
3 M Ω (High resistance (Mega Ω))
Yes
\geq 9.36 V DC (At 48 mA)
> 48 mA (With line fault detection)
> 22.5 V DC
\geq 269 Ω (Internal resistance R_i)
yes
< 30 ms
< 50 Ω (short circuit on the line)
> 10 k Ω (line break)
N/C contact
30 V DC
50 mA
yes
19.2 V DC ... 30 V DC (24 V DC -20%...+25%)
< 90 mA (24 V DC)
< 1.8 W
375 V (Peak value in accordance with EN 60079-11)
300 V _{rms} (Rated insulation voltage (overvoltage category II; degree of pollution 2, safe isolation as per EN 61010-1))
2.5 kV (50 Hz, 1 min., test voltage)
-20 °C ... 60 °C (Any mounting position)
10 % ... 95 % (non-condensing)
Green LED (supply voltage)
Yellow LED (switching state)
Red LED (line fault)
IP20
V0
PA 66-FR
12.5 / 112.5 / 114.5 mm
0.2 ... 2.5 mm ² / 0.2 ... 2.5 mm ² / 24 - 14
0.2 ... 1.5 mm ² / 0.2 ... 1.5 mm ² / 24 - 16
Class A product, see page 605
25.3 V
94 mA
595 mW
253 V AC/DC
CE-compliant, additionally EN 61326
[Ex ia Ga] IIC/IIB
[Ex ia Da] IIIC
[Ex ia Ga] IIC T4 Gc X
[Ex ia Ga] IIC/IIB, [Ex ia Da] IIIC, Ex nA [ia Ga] IIC T4 Gc 3

Ordering data

Description	Type	Order No.	Pcs./Pkt.
Solenoid driver , logic input, intrinsically safe output, line fault detection			
Screw connection	MACX MCR-EX-SL-SD-23-48-LFD	2924867	1
Push-in connection	MACX MCR-EX-SL-SD-23-48-LFD-SP	2924870	1

Digital OUT
Solenoid driver, Ex i

new

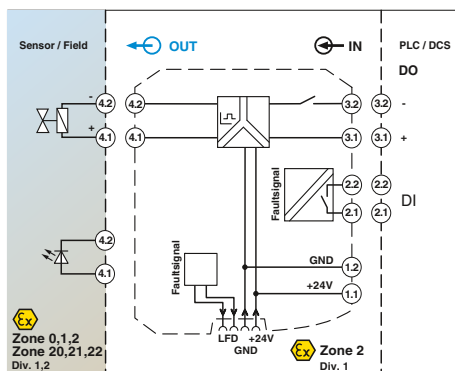
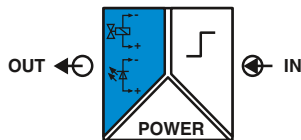

25.1 mA current limitation with line fault detection

Functional Safety
Ex: Ex i
Housing width 12.5 mm

Technical data

Solenoid driver for the intrinsically safe control of Ex i solenoid valves, alarm transmitters or indicators installed in the Ex area.

- Input: logic (low/high signal)
- Output: 25.1 mA current limitation at 4.64 V, [Ex ia]
- Line fault detection (can be activated and deactivated)
 - Directly via signal channel
 - Or via switching output
- Transparent for test pulses
- Power supply and error indication possible via the DIN rail connector
- LED indicators for supply voltage, status, and fault according to NAMUR NE 44
- Plug-in screw or Push-in connection technology
- Safe 3-way electrical isolation
- Up to SIL 3 according to IEC/EN 61508
- Installation in Zone 2 permitted

Input data

Switching level 0 signal ("L")
Switching level 1 signal ("H")
Current input signal
Input impedance in the event of a line fault at the output

Transparent for test pulses

Output data

Output voltage
Current limitation
No-load voltage
Internal resistance
Immunity to short-circuiting
Response time t_A
Line fault detection

Error message output

Switch contact
Max. switching voltage
Maximum switching current
Short-circuit-proof

General data

Supply voltage range
Current draw
Power dissipation
Electrical isolation

Output/input, error message output

Ambient temperature range

Humidity
Status indication

Degree of protection

Inflammability class in acc. with UL 94
Housing material
Dimensions W/H/D
Screw connection solid/stranded/AWG
Push-in connection solid/stranded/AWG
EMC note

Safety data as per ATEX

Maximum output voltage U_o
Maximum output current I_o
Maximum output power P_o
Maximum voltage U_m

Conformance/Approvals

Conformance
ATEX

IECEX

SIL in accordance with IEC 61508

0 V DC ... 5 V DC (Open)
15 V DC ... 30 V DC
< 12 mA
3 M Ω (High resistance (Mega Ω))

Yes

\geq 4.64 V DC (at 25.1 mA)
> 25.1 mA (With line fault detection)
> 21.1 V DC
 \geq 641 Ω (Internal resistance R_i)
yes
< 30 ms
< 50 Ω (short circuit on the line)
> 10 k Ω (line break)

N/C contact

30 V DC
50 mA
yes

19.2 V DC ... 30 V DC (24 V DC -20%...+25%)
< 50 mA (24 V DC)
< 0.8 W

375 V (Peak value in accordance with EN 60079-11)
300 V_{rms} (Rated insulation voltage (overvoltage category II; degree of pollution 2, safe isolation as per EN 61010-1))
2.5 kV (50 Hz, 1 min., test voltage)

-20 °C ... 60 °C (Any mounting position)
10 % ... 95 % (non-condensing)
Green LED (supply voltage)
Yellow LED (switching state)
Red LED (line fault)

IP20

V0

PA 66-FR

12.5 / 112.5 / 114.5 mm

0.2 ... 2.5 mm² / 0.2 ... 2.5 mm² / 24 - 14

0.2 ... 1.5 mm² / 0.2 ... 1.5 mm² / 24 - 16

Class A product, see page 605

23.98 V

37.4 mA

224 mW

253 V AC/DC

CE-compliant, additionally EN 61326

Ex II (1) G [Ex ia Ga] IIC/IB

Ex II (1) D [Ex ia Da] IIIC

Ex II 3(1) G Ex nA [ia Ga] IIC T4 Gc X

[Ex ia Ga] IIC/IB , [Ex ia Da] IIIC , Ex nA [ia Ga] IIC T4 Gc
3

Ordering data

Description
Solenoid driver, logic input, intrinsically safe output, line fault detection
Screw connection
Push-in connection

Type	Order No.	Pcs./ Pkt.
MACX MCR-EX-SL-SD-21-25-LFD	2905669	1
MACX MCR-EX-SL-SD-21-25-LFD-SP	2905674	1

Digital OUT
Solenoid driver, Ex i

new

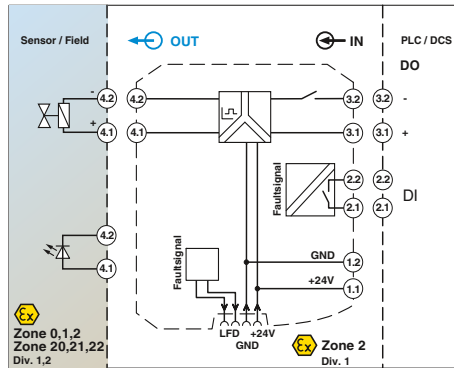
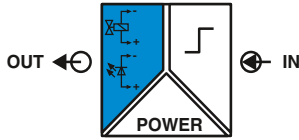

48 mA current limitation with line fault detection

Functional Safety
Ex:
Housing width 12.5 mm

Technical data

Solenoid driver for the intrinsically safe control of Ex i solenoid valves, alarm transmitters or indicators installed in the Ex area.

- Input: logic (low/high signal)
- Output: 48 mA current limitation at 9.7 V, [Ex ia]
- Line fault detection (can be activated and deactivated)
 - Directly via signal channel
 - Or via switching output
- Transparent for test pulses
- Power supply and error indication possible via the DIN rail connector
- LED indicators for supply voltage, status, and fault according to NAMUR NE 44
- Plug-in screw or Push-in connection technology
- Safe 3-way electrical isolation
- Up to SIL 3 according to IEC/EN 61508
- Installation in Zone 2 permitted

Input data

Switching level 0 signal ("L")
Switching level 1 signal ("H")
Current input signal
Input impedance in the event of a line fault at the output

Transparent for test pulses

Output data

Output voltage
Current limitation
No-load voltage
Internal resistance
Immunity to short-circuiting
Response time t_A
Line fault detection

Error message output

Switch contact
Max. switching voltage
Maximum switching current
Short-circuit-proof

General data

Supply voltage range
Current draw
Power dissipation
Electrical isolation

Output/input, error message output

Ambient temperature range
Humidity
Status indication

Degree of protection
Inflammability class in acc. with UL 94
Housing material
Dimensions W/H/D
Screw connection solid/stranded/AWG
Push-in connection solid/stranded/AWG
EMC note

Safety data as per ATEX

Maximum output voltage U_o
Maximum output current I_o
Maximum output power P_o
Maximum voltage U_m

Conformance/Approvals

Conformance
ATEX

IECEX
SIL in accordance with IEC 61508

0 V DC ... 5 V DC (Open)
15 V DC ... 30 V DC
< 12 mA
3 M Ω (High resistance (Mega Ω))

Yes

\geq 9.7 V DC (At 48 mA)
> 48 mA (With line fault detection)
> 24.3 V DC
 \geq 297 Ω (Internal resistance R_i)
yes
< 30 ms
< 50 Ω (short circuit on the line)
> 10 k Ω (line break)

N/C contact
30 V DC
50 mA
yes

19.2 V DC ... 30 V DC (24 V DC -20%...+25%)
< 90 mA (24 V DC)
< 1.62 W

375 V (Peak value in accordance with EN 60079-11)
300 V_{rms} (Rated insulation voltage (overvoltage category II; degree of pollution 2, safe isolation as per EN 61010-1))
2.5 kV (50 Hz, 1 min., test voltage)

-20 °C ... 60 °C (Any mounting position)
10 % ... 95 % (non-condensing)
Green LED (supply voltage)
Yellow LED (switching state)
Red LED (line fault)

IP20
V0
PA 66-FR
12.5 / 112.5 / 114.5 mm
0.2 ... 2.5 mm² / 0.2 ... 2.5 mm² / 24 - 14
0.2 ... 1.5 mm² / 0.2 ... 1.5 mm² / 24 - 16
Class A product, see page 605

27.06 V
91.11 mA
616 mW
253 V AC/DC

CE-compliant, additionally EN 61326
 II (1) G [Ex ia Ga] IIC/IIB
 II (1) D [Ex ia Da] IIIC
 II 3(1) G Ex nA [ia Ga] IIC T4 Gc X
[Ex ia Ga] IIC/IIB, [Ex ia Da] IIIC, Ex nA [ia Ga] IIC T4 Gc 3

Ordering data

Description	Type	Order No.	Pcs./Pkt.	
Solenoid driver, logic input, intrinsically safe output, line fault detection	Screw connection	MACX MCR-EX-SL-SD-24-48-LFD	2906155	1
	Push-in connection	MACX MCR-EX-SL-SD-24-48-LFD-SP	2906156	1

Digital OUT
Solenoid drivers, Ex i

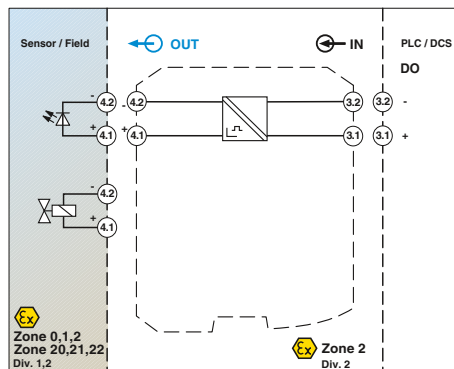
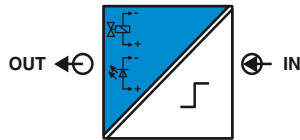

Current limitation 25 mA

Functional Safety
Ex: Ex EAC Ex Ex Ex Ex
Housing width 12.5 mm

Solenoid drivers for controlling intrinsically safe solenoid valves, alarm transmitters, and indicators installed in Ex areas.

- 20 to 30 V DC input
- Output [Ex ia]
- Various output characteristic curves compatible with the commercial solenoid valves
- Loop-powered: the required power is supplied via the control signal on the input side.
- Mechanically compatible with DIN rail connector
- 2-way electrical isolation
- Up to SIL 3 according to EN 61508
- Installation in Zone 2 permitted

Notes:
A list of suitable valves and notes for calculating a valve circuit are available from the download center at phoenixcontact.net/products.
Information on marking material can be found on page 177
Information on "Plug and play" connection using system cabling can be found from page 164

Input data	
Input signal	
Input current	
Output data	
Output voltage	
Current limitation	
No-load voltage	
Internal resistance	
Immunity to short-circuiting	
Response time t_A	
General data	
Power dissipation	
Temperature coefficient	
Electrical isolation	
Ambient temperature range	
Status indication	
Degree of protection	
Inflammability class in acc. with UL 94	
Dimensions W/H/D	
Screw connection solid/stranded/AWG	
Push-in connection solid/stranded/AWG	
EMC note	
Safety data as per ATEX	
Maximum output voltage U_o	
Maximum output current I_o	
Maximum output power P_o	
Maximum voltage U_m	
Conformance/Approvals	
Conformance	
ATEX	
IECEX	
UL, USA/Canada	
SIL in accordance with IEC 61508	

Technical data	
20 V DC ... 30 V DC (24 V DC -16.7 %...+25 %)	
10 mA ... 70 mA (45 mA for $U_o = 24$ V DC)	
5,5 V DC (At 25 mA)	
25 mA	
21.9 V DC	
641 Ω (Internal resistance R_i)	
yes	
20 ms	
< 1 W	
0.01 %/K	
Output/input	375 V (Peak value in accordance with EN 60079-11) 300 V r_{ms} (Rated insulation voltage (overvoltage category II; degree of pollution 2, safe isolation as per EN 61010-1)) 2.5 kV (50 Hz, 1 min., test voltage)
	-20 °C ... 60 °C (Any mounting position) Yellow LED (switching state / status, lights up when output circuit is active) IP20 V0 12.5 / 99 / 114.5 mm 0.2 ... 2.5 mm ² / 0.2 ... 2.5 mm ² / 24 - 14 0.2 ... 1.5 mm ² / 0.2 ... 1.5 mm ² / 24 - 16 Class A product, see page 605
	25.1 V 39 mA 245 mW 253 V AC (125 V DC)
	CE-compliant, additionally EN 61326 Ex II 3 G Ex nA IIC T4 Gc X Ex II (1) G [Ex ia Ga] IIC/II B/IIA Ex II (1) D [Ex ia Da] IIC [Ex ia Ga] IIC/II B/IIA , [Ex ia Da] IIC , Ex nA IIC T4 Gc X Class I Div 2; IS for Class I, II, III Div 1 3

Description	
Solenoid driver , loop-powered, output intrinsically safe	
	Screw connection Push-in connection

Ordering data		
Type	Order No.	Pcs./Pkt.
MACX MCR-EX-SL-SD-21-25-LP	2865492	1
MACX MCR-EX-SL-SD-21-25-LP-SP	2924113	1

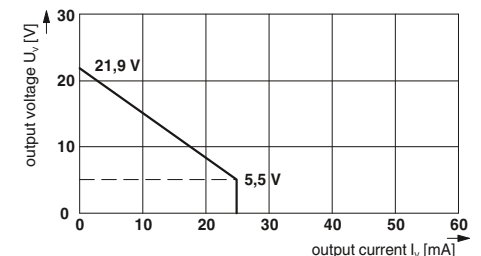

Ex i signal conditioners with SIL functional safety – MACX Analog Ex



Current limitation 40 mA



Current limitation 48 mA



Current limitation 58 mA, [Ex ia] IIB

Functional Safety
Ex: EAC Ex

Housing width 12.5 mm

Functional Safety
Ex: EAC Ex

Housing width 12.5 mm

Functional Safety
Ex: EAC Ex

Housing width 12.5 mm

Technical data
20 V DC ... 30 V DC (24 V DC -16.7 %...+25 %) 10 mA ... 95 mA (65 mA for U ₀ = 24 V DC)
10 V DC (At 40 mA) 40 mA 21.9 V DC 287 Ω (Internal resistance R _i) yes 20 ms
< 1.2 W 0.01 %/K
375 V (Peak value in accordance with EN 60079-11) 300 V _{rms} (Rated insulation voltage (overvoltage category II; degree of pollution 2, safe isolation as per EN 61010-1)) 2.5 kV (50 Hz, 1 min., test voltage)
-20 °C ... 60 °C (Any mounting position) Yellow LED (switching state / status, lights up when output circuit is active) IP20 V0 12.5 / 99 / 114.5 mm 0.2 ... 2.5 mm ² / 0.2 ... 2.5 mm ² / 24 - 14 0.2 ... 1.5 mm ² / 0.2 ... 1.5 mm ² / 24 - 16 Class A product, see page 605
25.1 V 87 mA 550 mW 253 V AC (125 V DC)
CE-compliant, additionally EN 61326 II 3 G Ex nA IIC T4 Gc X II (1) G [Ex ia Ga] IIC/IIB/IIA II (1) D [Ex ia Da] IIIC [Ex ia Ga] IIC/IIB/IIA Class I Div 2; IS for Class I, II, III Div 1 3

Technical data
20 V DC ... 30 V DC (24 V DC -16.7 %...+25 %) 10 mA ... 95 mA (75 mA for U ₀ = 24 V DC)
10.5 V DC (At 48 mA) 48 mA 24 V DC 276 Ω (Internal resistance R _i) yes 30 ms
< 1.4 W 0.01 %/K
375 V (Peak value in accordance with EN 60079-11) 300 V _{rms} (Rated insulation voltage (overvoltage category II; degree of pollution 2, safe isolation as per EN 61010-1)) 2.5 kV (50 Hz, 1 min., test voltage)
-20 °C ... 60 °C (Any mounting position) Yellow LED (switching state / status, lights up when output circuit is active) IP20 V0 12.5 / 99 / 114.5 mm 0.2 ... 2.5 mm ² / 0.2 ... 2.5 mm ² / 24 - 14 0.2 ... 1.5 mm ² / 0.2 ... 1.5 mm ² / 24 - 16 Class A product, see page 605
27.7 V 101 mA 697 mW 253 V AC (125 V DC)
CE-compliant, additionally EN 61326 II 3 G Ex nA IIC T4 Gc X II (1) G [Ex ia Ga] IIC/IIB/IIA II (1) D [Ex ia Da] IIIC [Ex ia Ga] IIC/IIB/IIA Class I Div 2; IS for Class I, II, III Div 1 3

Technical data
20 V DC ... 30 V DC (24 V DC -16.7 %...+25 %) 10 mA ... 105 mA (95 mA for U ₀ = 24 V DC)
12.9 V DC (At 58 mA) 58 mA 21.9 V DC 133 Ω (Internal resistance R _i) yes 30 ms
< 1.4 W 0.01 %/K
375 V (Peak value in accordance with EN 60079-11) 300 V _{rms} (Rated insulation voltage (overvoltage category II; degree of pollution 2, safe isolation as per EN 61010-1)) 2.5 kV (50 Hz, 1 min., test voltage)
-20 °C ... 60 °C (Any mounting position) Yellow LED (switching state / status, lights up when output circuit is active) IP20 V0 12.5 / 99 / 114.5 mm 0.2 ... 2.5 mm ² / 0.2 ... 2.5 mm ² / 24 - 14 0.2 ... 1.5 mm ² / 0.2 ... 1.5 mm ² / 24 - 16 Class A product, see page 605
25.1 V 188 mA 1.18 W 253 V AC (125 V DC)
CE-compliant, additionally EN 61326 II 3 G Ex nA IIC T4 Gc X II (1) G [Ex ia Ga] IIB/IIA II (1) D [Ex ia Da] IIIC [Ex ia Ga] IIB/IIA Class I Div 2; IS for Class I, II, III Div 1 3

Ordering data		
Type	Order No.	Pcs./ Pkt.
MACX MCR-EX-SL-SD-21-40-LP	2865764	1
MACX MCR-EX-SL-SD-21-40-LP-SP	2924139	1

Ordering data		
Type	Order No.	Pcs./ Pkt.
MACX MCR-EX-SL-SD-24-48-LP	2865609	1
MACX MCR-EX-SL-SD-24-48-LP-SP	2924126	1

Ordering data		
Type	Order No.	Pcs./ Pkt.
MACX MCR-EX-SL-SD-21-60-LP	2865515	1
MACX MCR-EX-SL-SD-21-60-LP-SP	2924100	1

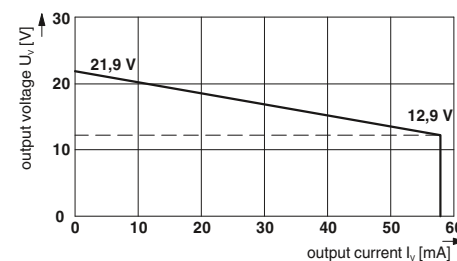
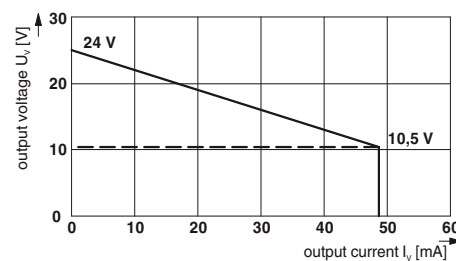
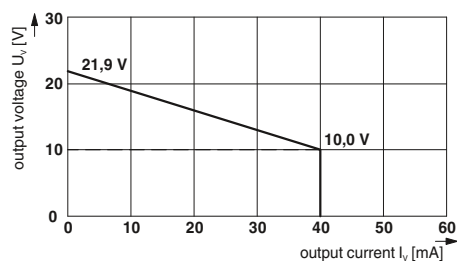

Termination Carrier for
MACX Analog Ex signal conditioners



Select standard DIN rail device



Select module carrier

TC... Termination Carriers are compact solutions for quickly and smoothly connecting DIN rail devices from the MACX Analog Ex series to input and output cards of automation systems using system cabling.

The Termination Carriers combine the advantages of modular DIN rail devices with those offered by plug and play rapid cabling solutions to provide a consistent solution for system technology.

Compact

- Space savings of up to 30%, thanks to compact design

Robust and reliable

- Stable, vibration-resistant aluminum carrier device profile
- PCB is completely decoupled from modules
- PCB without active components
- Redundant supply and monitoring in separate DIN rail module

Easy maintenance

- Use of standard DIN rail devices
- Easy access to connection points
- Quick and safe module connection with plug-in and coded cable sets

Flexible

- Horizontal or vertical DIN rail mounting
- Profile section without pitch markings for I/O cards with specific number of channels
- Can be specifically adapted for I/O cards of various automation systems with different system plug types



Select controller-specific front adapter and system cable



Solutions are also available for MINI Analog, MACX Analog Ex, and Safety

Termination Carrier for MACX Analog Ex signal conditioners

The **TC-D37SUB-ADIO16-EX-P-UNI** universal Termination Carrier is a compact solution which connects signal conditioners from the MACX Analog Ex series to analog or binary input/output cards of automation systems.

The **TC-D37SUB-AIO16-EX-PS-UNI** Termination Carrier design, when combined with the MACX MCR-S-MUX HART multiplexer, also enables communication between HART-capable field devices and a management system.

The **TC-D37SUB-ADIO16-2EX-P-UNI** universal Termination Carrier is a compact solution which connects two-channel signal conditioners from the MACX Analog Ex series to analog or binary input and output cards of automation systems.

- Connection of up to 16 single-channel (Ex i) signal conditioners
- Universal 1:1 signal routing to a 37-pos. D-SUB connector
- For system cables with D-SUB socket and open ends for universal connection
- Redundant supply and monitoring in separate DIN rail module

Notes:
Contact us: specific Termination Carrier designs for I/O modules of various automation systems are available, planned or can be implemented according to your specification.



ERC
Ex:
Housing width 242 mm

General data	
Connection to the control system level	D-SUB pin strip
Number of positions	37
Maximum operating voltage	< 30 V DC (Per signal/channel)
Maximum permissible current	23 mA (Signal/channel)
Rated insulation voltage	50 V
Degree of pollution	2
Overvoltage category	II
Rated surge voltage	0.5 kV
Air clearances and creepage distances	DIN EN 50178 (Basic insulation)
Ambient temperature range	-20 °C ... 60 °C (Please observe module specifications)
Shock	15g, according to IEC 60068-2-27
Vibration (operation)	2g, according to IEC 60068-2-6
Dimensions W/H/D	242 / 170 / 160 mm
EMC note	Class A product, see page 605
Power supply via power module	
Input voltage range	19.2 V DC ... 30 V DC
Redundant supply	yes, decoupled from diodes
Polarization and surge protection	Yes
Fuse	2x 2.5 A on PCB, slow-blow (replaceable)
Status indication	1 x red LED (error) 2x green LEDs (PWR1 and PWR2)
Switching output	1 N/C contact (alarm = open)
Maximum switching voltage	50 V DC (0.3 A) / 30 V DC (2 A) / 33 V AC (2 A)

Technical data		
Type	Order No.	Pcs./ Pkt.
TC-D37SUB-ADIO16-EX-P-UNI	2924854	1
TC-D37SUB-AIO16-EX-PS-UNI	2902932	1
TC-2D37SUB-ADIO32-2EX-P-UNI	2904684	1
Accessories		
TC-MACX-MCR-PTB	2904673	1
MACX MCR-S-MUX	2865599	1

Description	
Universal Termination Carrier for 16 single-channel MACX MCR-EX isolators	
- With connection for multiplexer	
Universal Termination Carrier for 16 two-channel MACX MCR-EX isolators	

Ordering data		
Type	Order No.	Pcs./ Pkt.
TC-D37SUB-ADIO16-EX-P-UNI	2924854	1
TC-D37SUB-AIO16-EX-PS-UNI	2902932	1
TC-2D37SUB-ADIO32-2EX-P-UNI	2904684	1

Power and fault signaling module	
HART multiplexer, 32-channel	

Accessories		
TC-MACX-MCR-PTB	2904673	1
MACX MCR-S-MUX	2865599	1

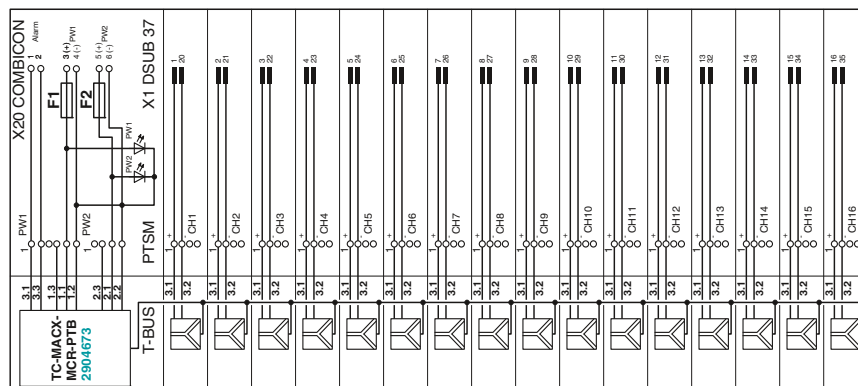

TC-D37SUB-ADIO16-EX-P-UNI and TC-D37SUB-AIO16-EX-PS-UNI connection scheme

Multiplexer for HART signals

Multiplexer for digital connection of HART-capable field devices (such as measuring transducers or control valves) to a PC or management system.

- Supports online configuration and diagnostics for the connected HART-capable field devices
- Constant documentation of process variables and states
- 32 HART channels per multiplexer
- Up to 128 HART multiplexers at one PC interface
- Communication via software tool (e.g. HART OPC Server) using RS-485 interface
- Electrical isolation between auxiliary energy, RS-485 bus, and the HART channels
- HART field devices are accessed at the same time that the measurement signal is transmitted without affecting measured value processing
- HART field devices connected via universal HART connection boards; direct connection if processing non-Ex signals, with separate Ex i signal isolator connected upstream if processing Ex signals
- Power supplied via HART connection board



Field devices interface (HART)	
Channels	16 or 32; adjustable using a switch
Connection method	Flat-ribbon cable, 14-pos. (inclusive)
Signal	HART FSK
HART specification	HART Field Communication Protocol Rev. 6.0 (downward compatible up to Rev 4.0); FSK Physical Layer Specification (Rev. 8.1)
Data transmission display	Two yellow "Tx" and "Rx" "HART" LEDs
Display error	Red "ERR" LED (flashes in case of an error in the HART bus)
RS-485 interface	
Connection method	D-SUB-9 socket
Signal	RS-485
Data flow control/protocols	Compatible with OPC HART server, PDM, PRM, and FDT/DTM
Number of HART multiplexers per bus segment	Max 31
Address setting	0...127; using a rotary switch at the front
Data rate	9600 / 19200 / 38400 / 57600 [bps]; via rotary switch at the front
Transmission length	≤ 1200 m
Display	Two yellow "Tx" and "Rx" "RS-485" LEDs
General data	
Supply voltage range	18 V ... 31.2 V
Nominal supply voltage	24 V DC
Current consumption	55 mA
Power consumption	1.35 W
Operating voltage display	Green "PWR" LED
Undervoltage monitoring	Yes (no faulty devices / output states)
Electrical isolation of HART signal/RS-485	350 V AC
Electrical isolation of HART signals between each other	100 V DC (Capacitive)
Electrical isolation of HART signal/supply	350 V AC
Electrical isolation of RS-485/supply	350 V AC
Error monitoring	Processor error: The "PWR" LED flashes; error in the HART communication: the "ERR" LED flashes
Ambient temperature range	-20 °C ... 60 °C
Humidity	≤ 95 % (non-condensing)
Dimensions W/H/D	35.2 / 99 / 114.5 mm
Conformance/Approvals	
Conformance	CE-compliant

ERC

Housing width 35.2 mm

Technical data

Technical data		
16 or 32; adjustable using a switch		
Flat-ribbon cable, 14-pos. (inclusive)		
HART FSK		
HART Field Communication Protocol Rev. 6.0 (downward compatible up to Rev 4.0); FSK Physical Layer Specification (Rev. 8.1)		
Two yellow "Tx" and "Rx" "HART" LEDs		
Red "ERR" LED (flashes in case of an error in the HART bus)		
RS-485 interface		
D-SUB-9 socket		
RS-485		
Compatible with OPC HART server, PDM, PRM, and FDT/DTM		
Max 31		
0...127; using a rotary switch at the front		
9600 / 19200 / 38400 / 57600 [bps]; via rotary switch at the front		
≤ 1200 m		
Two yellow "Tx" and "Rx" "RS-485" LEDs		
General data		
18 V ... 31.2 V		
24 V DC		
55 mA		
1.35 W		
Green "PWR" LED		
Yes (no faulty devices / output states)		
350 V AC		
100 V DC (Capacitive)		
350 V AC		
350 V AC		
Processor error: The "PWR" LED flashes; error in the HART communication: the "ERR" LED flashes		
-20 °C ... 60 °C		
≤ 95 % (non-condensing)		
35.2 / 99 / 114.5 mm		
Conformance/Approvals		
CE-compliant		

Ordering data

Description	HART multiplexer, 32-channel, including two 14-wire flat-ribbon cables
-------------	---

Type	Order No.	Pcs./ Pkt.
MACX MCR-S-MUX	2865599	1

Accessories

Universal Termination Carrier for 16 single-channel MACX MCR-EX isolators - With connection for multiplexer	
Module carrier for 16 MINI Analog channels, power and feed-through module - With connection for MACX MCR-S-MUX HART multiplexer	
HART connection board	
Interface converter	
Repeater, for electrical isolation and increased range	

Type	Order No.	Pcs./ Pkt.
TC-D37SUB-AIO16-EX-PS-UNI	2902932	1
TC-D37SUB-AIO16-M-PS-UNI	2902934	1
MACX MCR-S-MUX-TB	2308124	1
PSM-ME-RS232/RS485-P	2744416	1
PSM-ME-RS485/RS485-P	2744429	1

Analog IN

Repeater power supply, Ex i

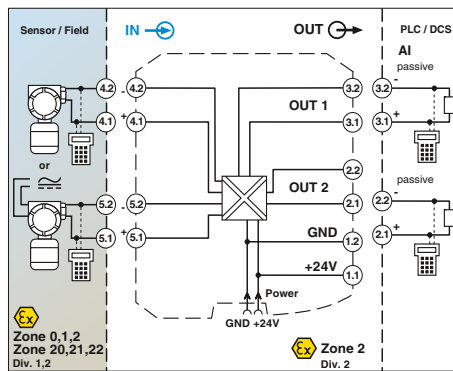
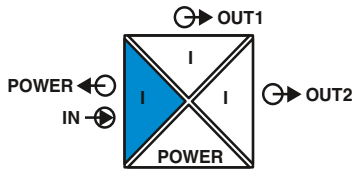

Repeater power supply and input signal conditioner, with two electrically isolated outputs

Housing width 12.5 mm

- 4 to 20 mA input, [Ex ia], powered and not powered
- Two electrically isolated outputs, 4 to 20 mA (active)
- PL d according to EN ISO 13849-1
- Up to SIL 2 according to IEC 61508
- Installation in Zone 2 possible
- Plug-in screw and Push-in connection technology
- 4-way electrical isolation
- Bidirectional HART communication possible
- Power supply via DIN rail connector possible

Notes:

Information about the supply and error evaluation module as well as about the DIN rail connectors and marking material can be found from page 174

Test plugs for test sockets can be found on page 176

Information on "Plug and play" connection using system cabling can be found from page 164

Input data	
Input signal	4 mA ... 20 mA / 4 mA ... 20 mA
Transmitter supply voltage	> 16 V (20 mA)
Voltage drop	approx. 3.9 V
Output data	
Output signal (Per output)	4 mA ... 20 mA (active)
Load	< 450 Ω (20 mA)
Output ripple	< 20 mV _{rms}
General data	
Supply voltage range	19.2 V DC ... 30 V DC (24 V DC -20%...+25%)
Current consumption	< 75 mA (24 V DC / 20 mA)
Power dissipation	< 1.45 W (24 V DC/ 20 mA)
Temperature coefficient	< 0.01 %/K
Step response (10-90%)	1.3 ms (for jump 4 mA ... 20 mA, typical)
Transmission error, typical	< 0.05 % (of final value)
Maximum transmission error	< 0.1 % (of final value)
Under-/overload range	according to NE 43
Electrical isolation	300 V _{rms} (Rated insulation voltage (overvoltage category II; degree of pollution 2, safe isolation as per EN 61010-1))
	2.5 kV (50 Hz, 1 min., test voltage)
Input/output/power supply	
Input/output	375 V (Peak value in accordance with EN 60079-11)
Input/power supply	375 V (Peak value in accordance with EN 60079-11)
Output 1/output 2	1.5 kV AC (50 Hz, 1 min., test voltage)
	-20 °C ... 60 °C (Any mounting position)
	Green LED (PWR supply voltage)
	Yes
	HART
	PA 66-FR
	12.5 / 99 / 114.5 mm
	0.2 ... 2.5 mm ² / 0.2 ... 2.5 mm ² / 24 - 14
	0.2 ... 1.5 mm ² / 0.2 ... 1.5 mm ² / 24 - 16
	Class A product, see page 605
Safety data as per ATEX	
Maximum output voltage U _o	25.2 V
Maximum output current I _o	93 mA
Maximum output power P _o	587 mW
Maximum voltage U _m	253 V AC (125 V DC)
Conformance/Approvals	
Conformance	CE-compliant, additionally EN 61326
ATEX	Ex II (1) G [Ex ia Ga] IIC/IIB Ex II (1) D [Ex ia Da] IIIC Ex II 3 (1) G Ex nA [ia Ga] IIC/IIB T4 Gc [Ex ia Ga] IIC/IIB , [Ex ia Da] IIIC , Ex nA [ia Ga] IIC/IIB T4 Gc
IECEX	2
SIL in accordance with IEC 61508	PLd
Performance level according to ISO 13849	

Technical data

Technical data	
4 mA ... 20 mA / 4 mA ... 20 mA	
> 16 V (20 mA)	
approx. 3.9 V	
4 mA ... 20 mA (active)	
< 450 Ω (20 mA)	
< 20 mV _{rms}	
19.2 V DC ... 30 V DC (24 V DC -20%...+25%)	
< 75 mA (24 V DC / 20 mA)	
< 1.45 W (24 V DC/ 20 mA)	
< 0.01 %/K	
1.3 ms (for jump 4 mA ... 20 mA, typical)	
< 0.05 % (of final value)	
< 0.1 % (of final value)	
according to NE 43	
300 V _{rms} (Rated insulation voltage (overvoltage category II; degree of pollution 2, safe isolation as per EN 61010-1))	
2.5 kV (50 Hz, 1 min., test voltage)	
375 V (Peak value in accordance with EN 60079-11)	
375 V (Peak value in accordance with EN 60079-11)	
1.5 kV AC (50 Hz, 1 min., test voltage)	
-20 °C ... 60 °C (Any mounting position)	
Green LED (PWR supply voltage)	
Yes	
HART	
PA 66-FR	
12.5 / 99 / 114.5 mm	
0.2 ... 2.5 mm ² / 0.2 ... 2.5 mm ² / 24 - 14	
0.2 ... 1.5 mm ² / 0.2 ... 1.5 mm ² / 24 - 16	
Class A product, see page 605	
25.2 V	
93 mA	
587 mW	
253 V AC (125 V DC)	
CE-compliant, additionally EN 61326	
Ex II (1) G [Ex ia Ga] IIC/IIB	
Ex II (1) D [Ex ia Da] IIIC	
Ex II 3 (1) G Ex nA [ia Ga] IIC/IIB T4 Gc	
[Ex ia Ga] IIC/IIB , [Ex ia Da] IIIC , Ex nA [ia Ga] IIC/IIB T4 Gc	
2	
PLd	

Ordering data

Description	Type	Order No.	Pcs./ Pkt.
Repeater power supply and input signal conditioner, signal duplicator, with performance level, intrinsically safe input			
Screw connection	MACX PL-EX-RPSSI-2I	2904959	1
Push-in connection	MACX PL-EX-RPSSI-2I-SP	2904960	1

Analog IN

Repeater power supply, Ex i

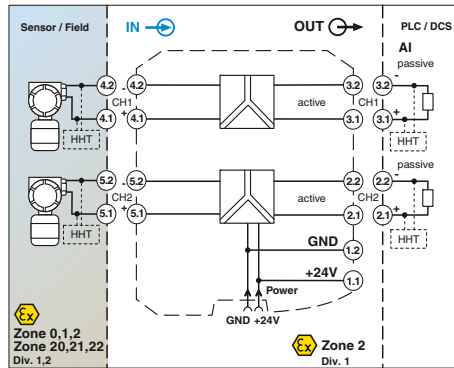
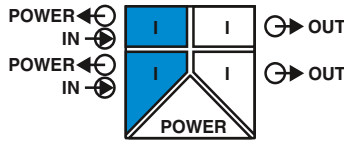

2-channel repeater power supply

Functional Safety
 Ex:
 Housing width 12.5 mm

- 2-channel
- 4 to 20 mA input, [Ex ia], powered
- 4 to 20 mA output (active)
- PL d according to EN ISO 13849-1
- Up to SIL 3 according to IEC 61508
- Installation in Zone 2 possible
- Plug-in screw and Push-in connection technology
- 3-way electrical isolation, per channel
- Bidirectional HART communication possible
- Power supply via DIN rail connector possible

Notes:

Information about the supply and error evaluation module as well as about the DIN rail connectors and marking material can be found from page 174

Test plugs for test sockets can be found on page 176

Information on "Plug and play" connection using system cabling can be found from page 164

Input data	per channel
Input signal	4 mA ... 20 mA
Transmitter supply voltage	> 16 V (at 20 mA)
Underload/overload signal range	0 mA ... 24 mA
Output data	per channel
Output signal	4 mA ... 20 mA (active)
Load	≤ 450 Ω (20 mA)
Underload/overload signal range	0 mA ... 24 mA
General data	
Supply voltage range	19.2 V DC ... 30 V DC (24 V DC -20%...+25%)
Current consumption	< 100 mA (24 V / 20 mA)
Power dissipation	< 1.4 W (at 24 V DC / 20 mA)
Temperature coefficient	< 0.01 %/K
Step response (10-90%)	< 1.3 ms (for 4 mA ... 20 mA step)
Transmission error, typical	< 0.05 % (of final value)
Maximum transmission error	< 0.1 % (of final value)
Electrical isolation	
Input/output, power supply	300 V _{ins} (Rated insulation voltage (overvoltage category II; degree of pollution 2, safe isolation as per EN 61010-1)) 2.5 kV (50 Hz, 1 min., test voltage)
Input/output	375 V (Peak value in accordance with EN 60079-11)
Input/power supply	375 V (Peak value in accordance with EN 60079-11)
Output 1/output 2/ power supply	1.5 kV (50 Hz, 1 min., test voltage)
Ambient temperature range	-20 °C ... 60 °C (Any mounting position)
Status indication	Green LED (supply voltage)
SMART communication	Yes
Signal bandwidth	as per HART specifications
Protocols supported	HART
Housing material	PA 66-FR
Dimensions W/H/D	12.5 / 99 / 114.5 mm
Screw connection solid/stranded/AWG	0.2 ... 2.5 mm ² / 0.2 ... 2.5 mm ² / 24 - 14
Push-in connection solid/stranded/AWG	0.2 ... 1.5 mm ² / 0.2 ... 1.5 mm ² / 24 - 16
EMC note	Class A product, see page 605
Safety data as per ATEX	
Maximum output voltage U _o	25.2 V
Maximum output current I _o	93 mA
Maximum output power P _o	587 mW
Maximum voltage U _m	253 V AC (125 V DC)
Conformance/Approvals	
Conformance	CE-compliant, additionally EN 61326
ATEX	II (1) G [Ex ia Ga] IIC/IIB II (1) D [Ex ia Da] IIIC II 3(1) G Ex nA [ia Ga] IIC T4 Gc [Ex ia Ga] IIC/IIB, [Ex ia Da] IIIC, Ex nA [ia Ga] IIC T4 Gc
IECEx	3
SIL in accordance with IEC 61508	PLd
Performance level according to ISO 13849	

Technical data

Technical data	
per channel	
4 mA ... 20 mA	
> 16 V (at 20 mA)	
0 mA ... 24 mA	
per channel	
4 mA ... 20 mA (active)	
≤ 450 Ω (20 mA)	
0 mA ... 24 mA	
19.2 V DC ... 30 V DC (24 V DC -20%...+25%)	
< 100 mA (24 V / 20 mA)	
< 1.4 W (at 24 V DC / 20 mA)	
< 0.01 %/K	
< 1.3 ms (for 4 mA ... 20 mA step)	
< 0.05 % (of final value)	
< 0.1 % (of final value)	
300 V _{ins} (Rated insulation voltage (overvoltage category II; degree of pollution 2, safe isolation as per EN 61010-1)) 2.5 kV (50 Hz, 1 min., test voltage)	
375 V (Peak value in accordance with EN 60079-11)	
375 V (Peak value in accordance with EN 60079-11)	
1.5 kV (50 Hz, 1 min., test voltage)	
-20 °C ... 60 °C (Any mounting position)	
Green LED (supply voltage)	
Yes	
as per HART specifications	
HART	
PA 66-FR	
12.5 / 99 / 114.5 mm	
0.2 ... 2.5 mm ² / 0.2 ... 2.5 mm ² / 24 - 14	
0.2 ... 1.5 mm ² / 0.2 ... 1.5 mm ² / 24 - 16	
Class A product, see page 605	
25.2 V	
93 mA	
587 mW	
253 V AC (125 V DC)	
CE-compliant, additionally EN 61326	
II (1) G [Ex ia Ga] IIC/IIB	
II (1) D [Ex ia Da] IIIC	
II 3(1) G Ex nA [ia Ga] IIC T4 Gc	
[Ex ia Ga] IIC/IIB, [Ex ia Da] IIIC, Ex nA [ia Ga] IIC T4 Gc	
3	
PLd	

Ordering data

Description	Type	Order No.	Pcs./Pkt.
Repeater power supply, two-channel, with performance level, intrinsically safe input			
Screw connection	MACX PL-EX-RPSS-2I-2I	2904963	1
Push-in connection	MACX PL-EX-RPSS-2I-2I-SP	2904964	1

Temperature

Temperature transducer, Ex i

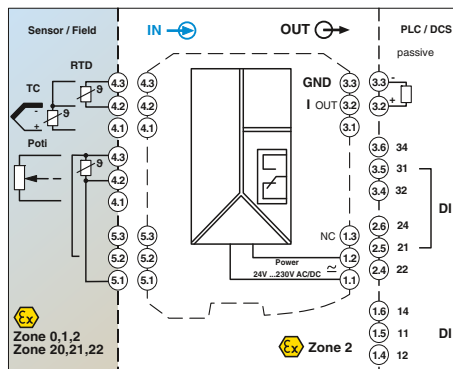
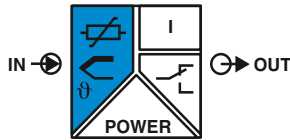

universal, with limit value relays, wide-range power supply

Ex: Ex EAC Ex
Housing width 35 mm

- Input for resistance thermometers, thermocouples, resistance-type sensors, potentiometers, mV sources, [Ex ia]
- Differential measurement possible with Pt 100
- A safety-related limit value relay, by bridging two relays
- An additional limit value relay for non-safety-related function
- PL d according to EN ISO 13849-1
- Up to SIL 2 according to IEC 61508
- Configuration via software (ANALOG-CONF or FDT/DTM)
- Cold junction compensation with separate connector
- Wide range power supply 19.2 to 253 V AC/DC
- Status indicators for supply voltage, cable, sensor, and module errors
- Installation in Zone 2 possible
- Plug-in screw and Push-in connection technology

Notes:
The configuration software can be downloaded from the Internet (phoenixcontact.net/products).
Information on the IFS-OP-UNIT operating and display unit and the associated IFS-OP-CRADLE DIN rail cradle can be found on page 171
For information on the programming adapter, refer to page 172

Input data	Resistance thermometers Thermocouple sensors
Resistor Potentiometer Voltage	
Output data	Output signal Maximum output signal Load R_B Behavior in the event of a sensor error
Switching output	Contact type Contact material Max. switching voltage Maximum switching current
General data	Supply voltage range Power consumption Temperature coefficient Maximum transmission error Electrical isolation
Safety data as per ATEX	Maximum output voltage U_o Maximum output current I_o Maximum output power P_o
Conformance/Approvals	Conformance ATEX IECEX SIL in accordance with IEC 61508 Performance level according to ISO 13849

Technical data	
Pt, Ni, Cu sensors: 2, 3, 4-wire B, E, J, K, N, R, S, T, L, U, CA, DA, A1G, A2G, A3G, MG, LG	
0 Ω ... 50 k Ω 0 Ω ... 50 k Ω -1000 mV ... 1000 mV	
4 mA ... 20 mA 22 mA $\leq 600 \Omega$ (20 mA) according to NE 43 or freely configurable Relay output 2 PDT AgSnO ₂ , hard gold-plated 250 V AC (250 V DC) 2 A (250 V AC) / 2 A (28 V DC)	
24 V ... 230 V AC/DC (-20 %/+10 %, 50/60 Hz) < 2.4 W 0.01 %/K 0.1 % (e.g. for Pt 100, 300 K span, 4 ... 20 mA)	
Input/output/power supply Input/output Input/power supply Input/switching output Output/supply	2.5 kV (50 Hz, 1 min., test voltage) 375 V (Peak value in accordance with EN 60079-11) 375 V (Peak value in accordance with EN 60079-11) 375 V (Peak value in accordance with EN 60079-11) 300 V _{rms} (Rated insulation voltage (overvoltage category II; degree of pollution 2, safe isolation as per EN 61010-1))
Ambient temperature range Humidity Inflammability class in acc. with UL 94 Housing material Dimensions W/H/D Screw connection solid/stranded/AWG Push-in connection solid/stranded/AWG EMC note	-20 °C ... 65 °C typ. 5 % ... 95 % (non-condensing) V0 PA 66-FR 35 / 99 / 114.5 mm 0.2 ... 2.5 mm ² / 0.2 ... 2.5 mm ² / 24 - 14 0.2 ... 1.5 mm ² / 0.2 ... 1.5 mm ² / 24 - 16 Class A product, see page 605
CE-compliant	CE-compliant Ex II (1) G [Ex ia Ga] IIC Ex II (1) D [Ex ia Da] IIIC Ex II 3 G Ex nA nC ic IIC T4 Gc X [Ex ia Ga] IIC, [Ex ia Da] IIIC, Ex nA nC ic IIC T4 Gc X 2 PLd

Description	
Temperature transducer with threshold value switch , with performance level, intrinsically safe input	
	Screw connection Push-in connection

Programming adapter for configuring modules with S-PORT interface	
--	--

Ordering data		
Type	Order No.	Pcs./Pkt.
MACX PL-EX-TUIREL-UP	2904910	1
MACX PL-EX-TUIREL-UP-SP	2904912	1

Accessories		
IFS-USB-PROG-ADAPTER	2811271	1

Accessories, operating and display unit

- Local display of actual values
- Copy function
- Easy guided operation
- Easy configuration without PC software
- Operating and display unit can be snapped directly onto compatible devices with a housing width of 35 mm
- DIN rail mounting possible for thinner devices in conjunction with cradle unit
- Backlighting
- Installation in Zone 2 permitted



Can be snapped directly onto compatible 35 mm devices

General data	
Ambient temperature range	-20 °C ... 65 °C (-4 °F...149 °F)
Humidity	90 % (at 25 °C, non-condensing)
Housing material	PA 6.6
Dimensions W/H/D	35 / 99 / 20 mm
Connection method	PC side Measuring transducer side
EMC note	
Conformance/Approvals	
Conformance	CE-compliant
ATEX	Ex II 3G Ex nA ic IIC T4 Gc X
IECEX	Ex nA ic IIC T4 Gc

Technical data		
Class A product, see page 605		
Ordering data		
Type	Order No.	Pcs./Pkt.
IFS-OP-UNIT	2811899	1

Description
Operating and display unit

Accessories, cradle unit

- For snapping onto the DIN rail
- For control cabinet mounting of the operating and display unit



Cradle for operating and display unit

General data	
Ambient temperature range	-20 °C ... 65 °C (-4 °F...149 °F)
Humidity	90 % (at 25 °C, non-condensing)
Housing material	PA 6.6
Dimensions W/H/D	35.2 / 29 / 99 mm
Connection method	IFS-OP-UNIT operator interface Measuring transducer side
EMC note	
Conformance/Approvals	
Conformance	CE-compliant
ATEX	Ex II 3G Ex nA ic IIC T4 Gc X
IECEX	Ex nA ic IIC T4 Gc

Technical data		
Class A product, see page 605		
Ordering data		
Type	Order No.	Pcs./Pkt.
IFS-OP-CRADLE	2811886	1

Description
Cradle unit, for snapping the operating and display unit onto the DIN rail

Accessories

Programming adapter

The IFS-USB-PROG-ADAPTER programming adapter is used for configuring Phoenix Contact Interface modules with S-PORT interface.

The adapter is used with FDT/DTM software or ANALOG-CONF software. For programming the MACX Analog, MINI Analog Pro, and MINI Analog.



Description	Ordering data		
	Type	Order No.	Pcs./Pkt.
Programming adapter for configuring modules with S-PORT interface	IFS-USB-PROG-ADAPTER	2811271	1

Accessories

Shield fast connection

- For connecting cable shielding to cable terminal points
- Can be connected to PLUGTRAB PT
- Easy assembly



Description	Ordering data		
	Type	Order No.	Pcs./Pkt.
Shield fast connection , for connection to PLUGTRAB PT			
For Ø 3-6 mm	SSA 3-6	2839295	10
For Ø 5-10 mm	SSA 5-10	2839512	10

Accessories

ME 6,2 TBUS... DIN rail connector

DIN rail connector (5-pos.) for bridging the supply voltage of 12.5 mm wide MACX analog modules

- Reduced wiring effort
- System can be extended or module replaced even while process is active
- Inter-extendable



Ordering data			
Description	Type	Order No.	Pcs./Pkt.
DIN rail connector (TBUS) , for bridging the supply voltage, can be snapped onto 35 mm DIN rails according to EN 60715, with UL approval			
Color: green	ME 6,2 TBUS-2 1,5/5-ST-3,81 GN	2869728	10

Accessories

Dummy - MACX MCR-EX-DUMMY-ISOLATOR

Dummy module with no function for connecting unused intrinsically safe signal cables, with plug-in connection terminal blocks.



Ordering data			
Description	Type	Order No.	Pcs./Pkt.
Dummy module with no function			
with screw connection	MACX MCR-EX-DUMMY-ISOLATOR	2904970	1
with Push-in connection	MACX MCR-EX-DUMMY-ISOLATOR-SP	2905846	1

Accessories

Power and fault signaling module

Power and fault signaling module for feeding the 24 V supply voltage to the DIN rail connectors and signaling line faults and power supply failures.

- One-time or redundant supply, decoupled from diode, protected against polarization
- Supply current up to 3.75 A
- Relay output (PDT) and flashing LED for error messages
- Error message in the event of a power supply failure or fuse fault
- Bus cable fault message for MACX MCR-...(2)NAM... devices connected via DIN rail connectors
- Replaceable fuse
- Installation in Zone 2 permitted

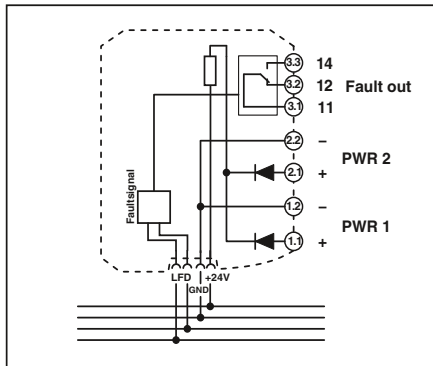

Ex n



Housing width 17.5 mm

Technical data

Input data	
Input signal	
Redundant supply	
Polarization and surge protection	
Output data	
Maximum output signal	
Output voltage	
Switching output	
Contact type	
Contact material	
Max. switching voltage	
General data	
Ambient temperature range	
Humidity	
Fuse	
Status indication	
Inflammability class in acc. with UL 94	
Housing material	
Dimensions W/H/D	
Screw connection solid/stranded/AWG	
Push-in connection solid/stranded/AWG	
EMC note	
Conformance/Approvals	
Conformance	
ATEX	
IECEX	
UL, USA/Canada	

19.2 V DC ... 30 V DC (24 V DC -20%...+25%)
yes, decoupled from diodes
Yes
3.75 A
Input voltage - max 0.8 V at 3.75 A
Relay
1 PDT
Gold (Au)
50 V AC (50 V DC (0.3 A) / 50 V DC (2 A) / 33 V AC (2 A))
-20 °C ... 60 °C (Any mounting position)
5% ... 95% (non-condensing)
5 A (replaceable), slow-blow 250 V AC
1 x red LED (error)
2 x green LEDs (PWR1 and PWR2)
V0
Polyamide (PA 6.6)
17.5 / 99 / 114.5 mm
0.2 ... 2.5 mm ² / 0.2 ... 2.5 mm ² / 24 - 14
0.2 ... 1.5 mm ² / 0.2 ... 1.5 mm ² / 24 - 16
Class A product, see page 605
CE-compliant
Ex II 3 G Ex nA nC IIC T4 Gc X
Ex nA nC IIC T4 Gc X
UL 61010 Listed
Class I, Div. 2, Groups A, B, C, D T5
Class I, Zone 2, Group IIC

Ordering data

Description
Power and fault signaling module , including the relevant DIN rail connector ME 17,5 TBUS 1,5/5-ST-3,81 GN
Screw connection
Push-in connection

Type	Order No.	Pcs./Pkt.
MACX MCR-PTB	2865625	1
MACX MCR-PTB-SP	2924184	1

Accessories

Power and fault signaling module

Power and fault signaling module for supplying the 24 V supply voltage to the DIN rail connectors of the MACX Analog Ex Termination Carriers and signaling line faults and power supply failures.

- One-time or redundant supply, decoupled from diode, protected against polarization
- Feed-in current up to 2 A protected by Termination Carrier PCB
- Relay output (PDT) and flashing LED for error messages
- Error message in the event of a power supply failure or fuse fault
- Bus cable fault message for MACX MCR-...(2)NAM... devices connected via DIN rail connectors
- Installation in Zone 2 possible



Housing width 17.5 mm

Technical data

Input data	
Input signal	19.2 V DC ... 30 V DC
Redundant supply	yes, decoupled from diodes
Polarization and surge protection	Yes
Output data	
Maximum output signal	2 A (Redundancy range)
Output voltage	Input voltage - 0.7 V
Switching output	
Contact type	Relay
Contact material	1 PDT
Max. switching voltage	Gold (Au)
General data	50 V AC/DC (33 V AC (2 A) / 50 V DC (0.3 A) / 30 V DC (2 A))
Ambient temperature range	-20 °C ... 60 °C (only on Termination Carrier)
Humidity	5 % ... 95 % (non-condensing)
Status indication	1 x red LED (error) 2 x green LEDs (PWR1 and PWR2) V0
Inflammability class in acc. with UL 94	Polyamide (PA 6.6)
Housing material	17.5 / 99 / 114.5 mm
Dimensions W/H/D	0.2 ... 2.5 mm ² / 0.2 ... 2.5 mm ² / 24 - 14
Screw connection solid/stranded/AWG	0.2 ... 2.5 mm ² / 0.2 ... 2.5 mm ² / 24 - 14
Push-in connection solid/stranded/AWG	Class A product, see page 605
EMC note	
Conformance/Approvals	
Conformance	CE-compliant
ATEX	Ex II 3 G Ex nA nC IIC T4 Gc X
IECEX	Ex nA nC IIC T4 Gc X
UL, USA/Canada	UL 61010 Listed Class I, Div. 2, Groups A, B, C, D T5 Class I, Zone 2, Group IIC

Ordering data

Description	Type	Order No.	Pcs./Pkt.
Power and fault signaling module without integrated fuse	Screw connection TC-MACX-MCR-PTB	2904673	1

Accessories

Resistance circuit

Double-level terminal block with resistance circuit according to NAMUR for line fault detection in the case of mechanical contacts

Important:

- For intrinsically safe circuits, only in combination with D-UKK 3/5 cover



		Ordering data		
Description	Color	Type	Order No.	Pcs./Pkt.
Double-level terminal block , with pre-assembled resistors				
with screw connection	gray	UKK 5-2R/NAMUR	2941662	50
Cover , width 2.5 mm	gray	D-UKK 3/5	2770024	50
	blue	D-UKK 3/5 BU	2770105	50

Accessories

Test plug



		Ordering data		
Description	Color	Type	Order No.	Pcs./Pkt.
Test plug , consisting of:				
Metal part for 2.3 mm Ø socket hole and	silver	MPS-MT	0201744	10
Insulating sleeve , for MPS metal part	red	MPS-IH RD	0201676	10
	black	MPS-IH BK	0201731	10
	gray	MPS-IH GY	0201728	10
	green	MPS-IH GN	0201702	10
	yellow	MPS-IH YE	0201692	10
	blue	MPS-IH BU	0201689	10
	white	MPS-IH WH	0201663	10

Accessories

Marking material for device marking

- For device marking inside the control cabinet and in the field
- Self-adhesive with high adhesive strength
- Large temperature range



		Ordering data		
Description	Color	Type	Order No.	Pcs./Pkt.
UniCard , with self-adhesive plastic labels				
10-part, lettering field size: 11 x 9 mm	white	UC-EMLP (11X9)	0819291	10
UniCard , with self-adhesive plastic labels, marked according to customer specifications For ordering details, see Catalog 3 or phoenixcontact.net/product.				
10-part, lettering field size: 11 x 9 mm	white	UC-EMLP (11X9) CUS	0824547	1



The Field Analog process indicators allow you to monitor and display analog and temperature signals as well as control them via digital and analog inputs and outputs.

Further advantages:

- 2-conductor sensors are powered by the integrated measuring transducer supply
- International use, thanks to UL and CSA approvals



Universal use

Field Analog process indicators are available for field and control panel installation. The universal inputs allow you to record current, voltage, RTDs, and TCs.



Everything at a glance

Current process values are easy to read on the five-digit backlit displays. The bar graph also provides you with a quick overview. You can recognize alarm statuses easily from a distance by their changing color.



Easy installation and startup

Thanks to the standardized housing dimensions and plug-in connection terminal blocks, the indicators are easy to install. The devices are easy to configure via the keypad on the front or via FDT/DTM software.



Intrinsic safety Zone 0, Zone 20

Also for intrinsically safe circuits in the Ex area: versions with ATEX, CSA, and FM approval.



Distributed control cabinet installation

MCR temperature transducers for resistance thermometers, thermocouples, resistance-type sensors, and voltage sensors are also available for control cabinet installation.



Head-mounted transducer

With head-mounted transducers you can record temperatures directly in the field and convert them into standard signals.

Multifunctional process indicator

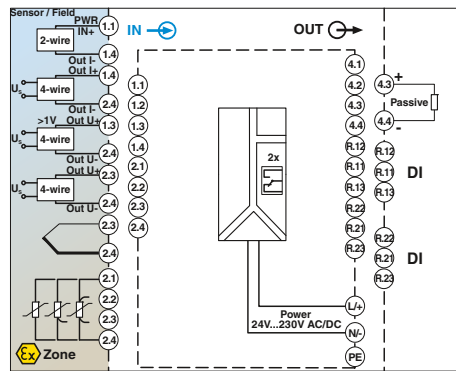
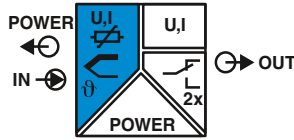

Multifunctional process indicator for installation in the control cabinet

Phoenix Contact DNV GL
Housing width 96 mm

For installation in the control cabinet

- Multifunctional process indicator, in control panel component housing for monitoring and displaying analog measurement data
- Supply of 2-conductor sensors
- Safe 4-way isolation
- Configurable via software or hardware keypad on the front
- Universal inputs for connection of current, voltage, RTDs, and TCs
- Limit value monitoring with two relay outputs
- Process signal transmission via analog output
- Display changes color in the event of an error

Notes:
The configuration software can be downloaded from the Internet (phoenixcontact.net/products).

Input data	Input signal
Input data	Sensor types that can be used Connection method Measuring rate Temperature measuring range
Input resistance	-
Output data	U output I output
Output signal	0 V ... 10 V 2 V ... 10 V 0 V ... 5 V 1 V ... 5 V
Display	7-segment LC display, with backlight, dot matrix for text/bar graph
Number of the displayed positions	5
Switching output	Transistor output, active Open collector output 1
Number of outputs	1
Switching output	Relay output 2 PDT 30 V DC (3 A) / 230 V AC (3 A) 3 A 10 mA
General data	Supply voltage range Degree of protection Ambient temperature (operation) Housing material Dimensions W/H/D Control panel cutout Screw connection solid/stranded/AWG
Conformance/Approvals	FA MCR-D-TUI-UI-2REL-UP CE-compliant ATEX UL, USA/Canada FM approval CSA GL

Technical data

U input	0 V ... 10 V 2 V ... 10 V 0 V ... 5 V 0 V ... 1 V 1 V ... 5 V -1 V ... 1 V -10 V ... 10 V -30 V ... 30 V -100 mV ... 100 mV	I input	0 mA ... 20 mA +10 % 4 mA ... 20 mA +10 %
RTD	Pt, Ni, Cu sensors 2, 3, 4-wire 200 ms -200 °C ... 1100 °C (Range depends on sensor type, adjustable)	TC	J, K, T, N, B, S, R, U, L, C, D - 200 ms -200 °C ... 2495 °C (Range depends on sensor type, adjustable)
Input resistance	-		10 Ω
U output	0 V ... 10 V 2 V ... 10 V 0 V ... 5 V 1 V ... 5 V	I output	0 mA ... 20 mA 4 mA ... 20 mA
Switching output	Transistor output, active Open collector output 1	Relay output	2 PDT 30 V DC (3 A) / 230 V AC (3 A) 3 A 10 mA
General data	24 V DC ... 230 V DC IP65 from the front -20 °C ... 60 °C PC-GF10 96 / 48 / 151.8 mm 92 x 45 mm 0.14 ... 1.5 mm ² / 0.14 ... 1.5 mm ² / 26 - 16		
Conformance/Approvals	FA MCR-D-TUI-UI-2REL-UP CE-compliant ATEX UL, USA/Canada FM approval CSA GL	FA MCR-EX-D-TUI-UI-2REL-UP CE-compliant Ex II (1) G [Ex ia Ga] IIC UL 61010 Recognized AIS, NII/2/ABCDEF/G/T4 AIS, NII/2/ABCDEF/G/T4 EMC1 C	

Description	Multifunctional process indicator, in control panel component housing for monitoring and displaying analog measurement data
--------------------	---

Ordering data

Type	Order No.	Pcs./ Pkt.
FA MCR-D-TUI-UI-2REL-UP	2907064	1
FA MCR-EX-D-TUI-UI-2REL-UP	2907216	1

Software adapter cable, 2.4 m long, with USB connection, for programming

Accessories

MCR-PAC-T-USB	2309000	1
---------------	---------	---

Multifunctional process indicator

new

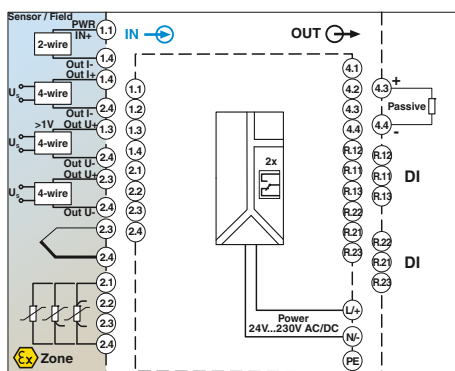
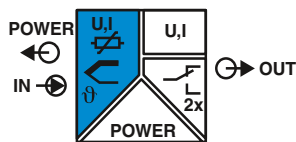

Multifunctional process indicator in field housing



Housing width 199 mm

Field housing

- Multifunctional process indicator, in control panel component housing for monitoring and displaying analog measurement data
- Supply of 2-conductor sensors
- Safe 4-way isolation
- Configurable via software or hardware keypad on the front
- Universal inputs for connection of current, voltage, RTDs, and TCs
- Limit value monitoring with two relay outputs
- Process signal transmission via analog output
- Display changes color in the event of an error

Notes:

The configuration software can be downloaded from the Internet (phoenixcontact.net/products).

Technical data	
Input data	
Input signal	U input 0 V ... 10 V 2 V ... 10 V 0 V ... 5 V 0 V ... 1 V 1 V ... 5 V -1 V ... 1 V -10 V ... 10 V -30 V ... 30 V -100 mV ... 100 mV
	I input 0 mA ... 20 mA +10 % 4 mA ... 20 mA +10 %
Input data	
Sensor types that can be used	RTD TC
Connection method	Pt, Ni, Cu sensors J, K, T, N, B, S, R, U, L, C, D
Measuring rate	2, 3, 4-wire -
Temperature measuring range	200 ms 200 ms -200 °C ... 1100 °C (Range depends on sensor type, adjustable) -200 °C ... 2495 °C (Range depends on sensor type, adjustable)
Input resistance	- 10 Ω
Output data	
Output signal	U output I output 0 V ... 10 V 0 mA ... 20 mA 2 V ... 10 V 4 mA ... 20 mA 0 V ... 5 V 1 V ... 5 V
Display	7-segment LC display, with backlight, dot matrix for text/bar graph
Number of the displayed positions	5
Switching output	
Number of outputs	Transistor output, active
Switching output	Open collector output
Contact type	1
Max. switching voltage	Relay output
Maximum switching current	2 PDT
Minimum switching current	30 V DC (3 A) / 230 V AC (3 A)
General data	
Supply voltage range	24 V DC ... 230 V DC
Degree of protection	IP67
Ambient temperature (operation)	-40 °C ... 50 °C (The readability of the display is no longer guaranteed at temperatures below -30 °C (-22 °F).)
Housing material	PBT GF30
Dimensions W/H/D	199 / 160 / 96 mm
Screw connection solid/stranded/AWG	0.2 ... 2.5 mm ² / 0.2 ... 2.5 mm ² / 24 - 14
Conformance/Approvals	
Conformance	FA MCR-FD-TUI-UI-2REL-UP FA MCR-EX-FD-TUI-UI-2REL-UP
ATEX	CE-compliant CE-compliant
UL, USA/Canada	- Ex II (1) G [Ex ia Ga] IIC
FM approval	UL 61010 Recognized UL 61010 Recognized
CSA	- AIS / I / 1 / ABCDEFG
	CSA GP Associated Apparatus

Ordering data		
Type	Order No.	Pcs./ Pkt.
FA MCR-FD-TUI-UI-2REL-UP	2907780	1
FA MCR-EX-FD-TUI-UI-2REL-UP	2907781	1

Accessories		
Type	Order No.	Pcs./ Pkt.
MCR-PAC-T-USB	2309000	1
FA MCR-FD-PM	2908739	1

Software adapter cable, 2.4 m long, with USB connection, for programming
Pipe or wall mounting set, for use with multi-functional process indicator in field housing

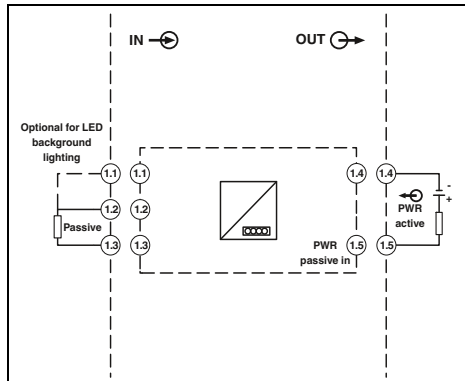
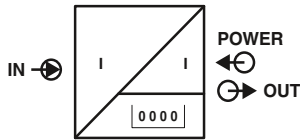

Loop-powered process indicator with HART communication for installation in the control cabinet

For installation in the control cabinet

- Loop-powered
- Display of 4 to 20 mA or HART signals
- Low voltage drop
- 5-digit 7-segment display
- Display value can be scaled
- Low installation depth
- Configurable via front keypad
- SIL-impact-free according to EN61508

Input data	Input signal Maximum input signal Voltage drop
Input impedance	
Output data	Display
Number of the displayed positions	5
General data	Supply voltage range
Resolution A/D	> 13 bit
Degree of protection	IP65 (Front) IP20 (On the rear)
Ambient temperature (operation)	-40 °C ... 60 °C
Housing material	Aluminum / polycarbonate
Dimensions W/H/D	96 / 48 / 41.5 mm
Control panel cutout	92 x 45 mm
Screw connection solid/stranded/AWG	0.14 ... 1.5 mm ² / 0.14 ... 1.5 mm ² / 26 - 16
Conformance/Approvals	CE-compliant
Conformance	

Housing width 96 mm

Technical data	
I	HART
4 mA ... 20 mA	up to 4x HART signals
200 mA	-
≤ 1 V	≤ 1.9 V
≤ 3.9 V (with display lighting)	≤ 4.8 V (with display lighting)
approx. 50 Ω	$R_x = 40 \Omega / C_x = 2.3 \text{ nF}$
7-segment LC display, with backlight, dot matrix for text/bar graph	
5	
loop-powered, no external supply necessary	

Description	Output loop-powered process indicator inside the control panel housing for representing current or HART signals
--------------------	--

Ordering data		
Type	Order No.	Pcs./ Pkt.
FA MCR-DS-I-I-OLP	2908781	1

new

Loop-powered process indicator

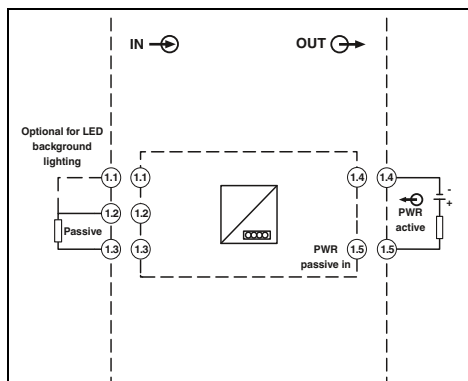
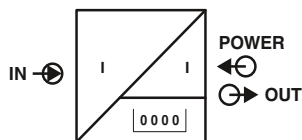

Loop-powered process indicator with HART communication in field housing

Field housing

- Loop-powered
- Display of 4 to 20 mA or HART signals
- Low voltage drop
- 5-digit 7-segment display
- Display value can be scaled
- Low installation depth
- Configurable via front keypad
- SIL-impact-free according to EN61508

Input data	
Input signal	4 mA ... 20 mA
Maximum input signal	200 mA
Voltage drop	≤ 1 V
	≤ 3.9 V (with display lighting)
Input impedance	approx. 50 Ω
Output data	
Display	7-segment LC display, with backlight, dot matrix for text/bar graph
Number of the displayed positions	5
General data	
Supply voltage range	loop-powered, no external supply necessary
Resolution A/D	> 13 bit
Degree of protection	IP66/IP67
	NEMA 4X
Ambient temperature (operation)	-40 °C ... 60 °C
Housing material	Aluminum
Dimensions W/H/D	131 / 81.5 / 55.5 mm
Screw connection solid/stranded/AWG	0.14 ... 1.5 mm ² / 0.14 ... 1.5 mm ² / 26 - 16
Conformance/Approvals	
Conformance	CE-compliant

Housing width 131 mm

Technical data	
I	HART
	up to 4x HART signals
	-
	≤ 1.9 V
	≤ 4.8 V (with display lighting)
	R _x = 40 Ω / C _x = 2.3 nF
	7-segment LC display, with backlight, dot matrix for text/bar graph
	5
	loop-powered, no external supply necessary
	> 13 bit
	IP66/IP67
	NEMA 4X
	-40 °C ... 60 °C
	Aluminum
	131 / 81.5 / 55.5 mm
	0.14 ... 1.5 mm ² / 0.14 ... 1.5 mm ² / 26 - 16
	CE-compliant

Description
Output loop-powered process indicator inside field housing for representing current or HART signals

Ordering data		
Type	Order No.	Pcs./ Pkt.
FA MCR-FDS-I-I-OLP	2908782	1

Pipe or wall mounting set , for use with output loop-powered process indicator in field housing
--

Accessories		
FA MCR-FDS-PM	2908783	1

Displays
Standard signals

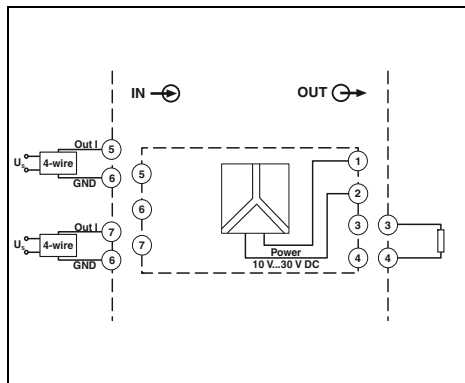
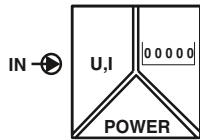

for standard analog signals,
configurable

- For 0 to 10 V and 0(4) to 20 mA standard analog signals
- Configurable
- 5 positions displayed
- 8 mm LED, 7-segment
- Electrical isolation
- Minimum/maximum value storage
- Latch/hold function for storing the display value
- Display 48 x 24 mm

Input data	
Input signal	
Maximum input signal	
Input resistance	
Resolution	
Measuring rate	
Input latch signal	
Switching level	1 signal ("H") 0 signal ("L")

Output data	
Display	
Number of the displayed positions	
Accuracy	

General data	
Supply voltage range	
Current consumption	
Mass storage	
Resolution A/D	
System hum suppression	
Test voltage input/power supply	
Degree of protection	
Ambient temperature (operation)	
Housing material	
Dimensions W/H/D	
Control panel cutout	
Screw connection solid/stranded/AWG	
Conformance/Approvals	
Conformance	
UL, USA/Canada	

Phoenix Contact
Housing width 48 mm

Technical data	
U input	I input
0 ... 10 V	0 ... 20 mA / 4 ... 20 mA
30 V DC	50 mA
> 1 MΩ	approx. 100 Ω with 5 mA / approx. 70 Ω with 20 mA
1 mV	2 μA
0.5 to 2 measurements/second	
Display stop	
4 V DC ... 30 V DC	
0 V DC ... 2 V DC	
7-segment LED; 8 mm; red	
5	
< 0.1 % ±1 digit (At an ambient temperature of 20°C)	
10 V DC ... 30 V DC	
50 mA	
EEPROM 1 mil. memory cycles or 10 years	
14 bit	
Digital filtering 50/60 Hz	
500 V _{rms} (50/60 Hz, 1 min.)	
IP65 from the front	
-10 °C ... 50 °C	
Macrolon 2405	
48 / 24 / 68 mm	
22(+0.6)x45(+0.8) mm	
0.14 ... 1.5 mm ² / 0.14 ... 1.5 mm ² / 26 - 16	
CE-compliant	
UL 508 Recognized	

Description
MCR process display , for measuring and displaying standard signals

Ordering data		
Type	Order No.	Pcs./ Pkt.
MCR-SL-D-U-I	2864011	1

Description
MCR DIN rail adapter for digital displays in a 24 x 48 mm housing

Accessories		
Type	Order No.	Pcs./ Pkt.
MCR-SL-D-RA	2810081	1

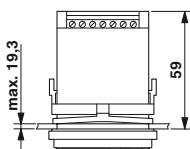
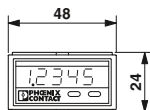

Displays
Frequency

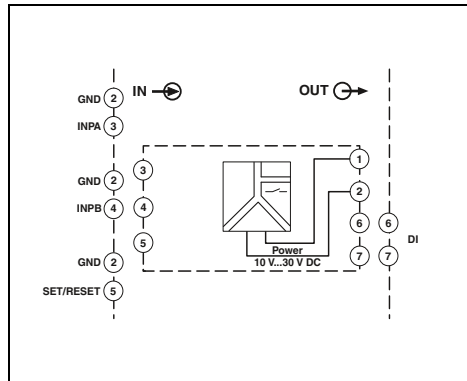
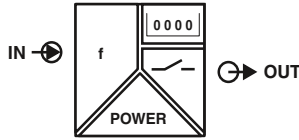

Programmable digital display for frequencies, pulses, and times

- For frequency signals up to max. 60 kHz
- Configurable
- 6 positions displayed
- LED 8 mm, 7 segment
- 48 x 24 mm display

Input data	
Maximum input signal	60 kHz
Input resistance	10 kΩ
Switching level	1 signal ("H") 0 signal ("L")
Output data	
Display	7-segment LED; 8 mm; red
Number of the displayed positions	6
Switching output	
Max. switching voltage	30 V DC
Maximum switching current	10 mA
General data	
Supply voltage range	10 V DC ... 30 V DC
Current consumption	max. 40 mA
Mass storage	EEPROM 1 mil. memory cycles or 10 years
Degree of protection	IP65 from the front
Ambient temperature (operation)	-20 °C ... 65 °C
Housing material	Macrolon 2405
Dimensions W/H/D	48 / 24 / 68 mm
Control panel cutout	22(+0.6)x45(+0.8) mm
Screw connection solid/stranded/AWG	0.14 ... 1 mm ² / 0.14 ... 1.5 mm ² / 26 - 16
Conformance/Approvals	
Conformance	CE-compliant
UL, USA/Canada	UL 508 Recognized

ERIC
Housing width 48 mm

Technical data

Ordering data		
Type	Order No.	Pcs./Pkt.
MCR-SL-D-FIT	2864024	1
Accessories		
MCR-SL-D-RA	2810081	1

Description
MCR digital display, for measurement and display of frequencies, pulses, and times
MCR DIN rail adapter for digital displays in a 24 x 48 mm housing

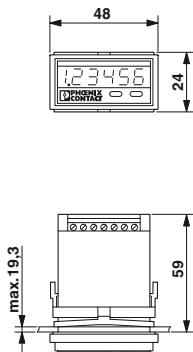

Displays
Setpoint adjuster

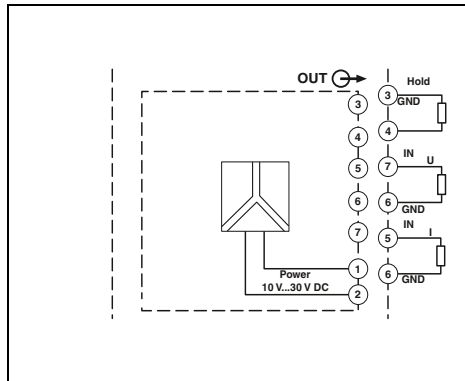
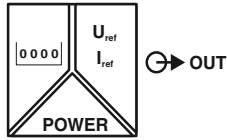

With manual and automatic ramp function

- Manual setpoint definition with incremental adjustment
- Manual setpoint definition via direct input
- Automatic setpoint definition with hold function and 20 interpolation points
- Flexible, adjustable signal ranges of 0 to 12 V or 0 to 24 mA
- Data backup in the event of power failure
- Display value parameterization
- Electrical isolation between output and supply

Input data	
Display	7-segment, 8 mm, red
Number of the displayed positions	4
Switching level	1 signal ("H") 0 signal ("L")
Output data	
Output signal	U output 0 ... 12 V
Length of step	I output 0 ... 24 mA
Load R _B	10 mV 10 μA
Ripple	≥ 2 kΩ ≤ 10 mV _{pp}
General data	
Supply voltage range	10 V DC ... 30 V DC
Power consumption	1 W (With 24 mA/12 V)
Maximum transmission error	< 0.2 % ((full-scale) at rated voltage)
Test voltage output/power supply	500 V AC (50 Hz, 1 min.)
Degree of protection	IP65 from the front
Ambient temperature (operation)	-20 °C ... 65 °C
Housing material	Macrolon 2405
Dimensions W/H/D	48 / 24 / 68 mm
Control panel cutout	45(+0.6)x22.2(+0.3) mm
Screw connection solid/stranded/AWG	0.14 ... 1.5 mm ² / 0.14 ... 1.5 mm ² / 26 - 16
Conformance/Approvals	
Conformance	CE-compliant
UL, USA/Canada	UL 508 Recognized



Housing width 48 mm

Technical data

Ordering data		
Type	Order No.	Pcs./Pkt.
MCR-SL-D-SPA-UI	2710314	1
Accessories		
MCR-SL-D-RA	2810081	1

Description
MCR digital setpoint adjuster, for presetting current and voltage signals

MCR DIN rail adapter for digital displays in a 24 x 48 mm housing

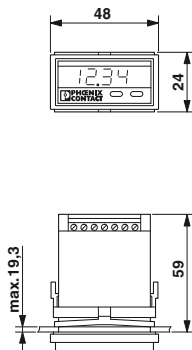

new

Temperature
Head-mounted temperature
transducer

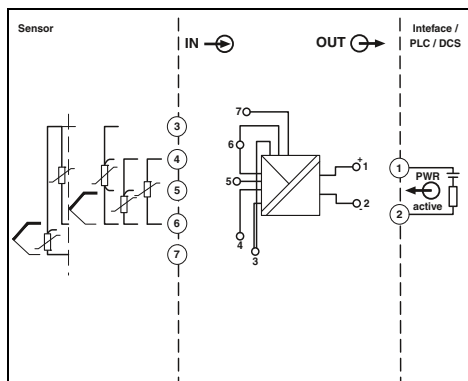
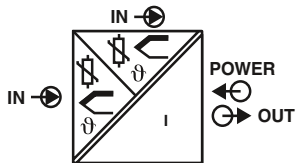

Block diagram for FA MCR-HT-TS-I-OLP-PT



Loop-powered
head-mounted temperature transducer

- Output loop-powered head-mounted temperature transducer
- 2 universal inputs for RTD, TC, resistance-type sensors, and voltage sensors (mV)
- 4 to 20 mA output
- HART communication
- Freely configurable
- SIL 2/3
- For mounting in the connecting head, form B

Input data	Resistance thermometers Thermocouple sensors Resistor Input voltage range
Output data	Output signal Maximum output signal Load R_B Switch-on delay
General data	Supply voltage range Current consumption Step response (0–99%) Electrical isolation
Degree of protection	Input/output IP33 (upon installation in field housing IP66/67, NEMA 4X)
Ambient temperature (operation)	-40 °C ... 85 °C
Screw connection solid/stranded/AWG	0.2 ... 1.5 mm ² / 0.2 ... 1.5 mm ² / 24 - 16
Conformance/Approvals	CE-compliant ATEX II 3G Ex nA IIC T6 Gc

Technical data		
Pt, Ni, Cu sensors: 2, 3, 4-wire : - A, B, C, D, E, J, K, L, N, R, S, T, U 10 Ω ... 2000 Ω (Minimum measuring span: 10 Ω) -20 mV ... 100 mV		
4 ... 20 mA , HART / 20 ... 4 mA 22.5 mA (U _L - 11 V) / 0.023 A approx. 10 s (HART) approx. 28 s (Measured value)		
-12 V DC ... 42 V DC 23.5 mA 0.8 s (TC)		
2 kV AC IP33 (upon installation in field housing IP66/67, NEMA 4X)		
-40 °C ... 85 °C 0.2 ... 1.5 mm ² / 0.2 ... 1.5 mm ² / 24 - 16		
CE-compliant ATEX II 3G Ex nA IIC T6 Gc		

Description	Output loop-powered head-mounted temperature transducer, for RTD, TC, resistance-type sensors, and voltage sensors (mV)	
--------------------	--	--

Ordering data		
Type	Order No.	Pcs./Pkt.
FA MCR-HT-TS-I-OLP-PT	2908742	1

Software adapter cable, 2.4 m long, with USB connection, for programming

Accessories		
MCR-PAC-T-USB	2309000	1
FA MCR-HT-D	2908735	1

Temperature
Head-mounted temperature
transducer

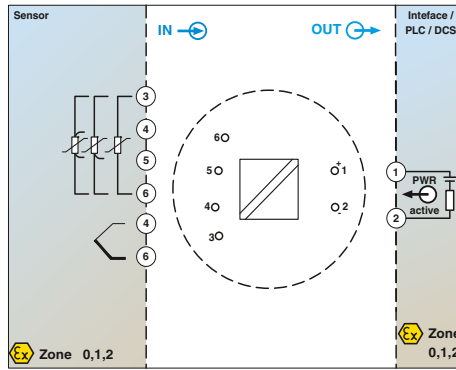
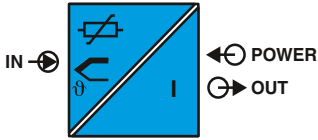

Loop-powered,
programmable



- 1-channel
- Loop-powered
- Input for resistance thermometers, thermocouples, and linear mV signals, Ex ia IIC
- 4 to 20 mA / 20 to 4 mA output
- Can be installed in Zone 0
- 2-way electrical isolation
- HART-compatible

Notes:
The devices are supplied with the standard configuration: Pt100 sensor, 0 to 100°C measuring range, 3-conductor connection.
To configure the MCR-FL-TS-LPI-EX HART-capable device, you need a HART modem.

Measuring input	
Resistance thermometers Thermocouple sensors	
Resistor	
Voltage Configuration	
Measuring output	
Output signal range Maximum output signal Load Line monitoring Short-circuit current	
Output current with open circuit Output current, measuring range overrange/underrange	
General data	
Supply voltage range Current consumption Step response (10-90%) Transmission error	
Resistance thermometers	
Thermocouple sensors	
Resistance-type sensors	
Voltage sensor	
Test voltage input/output Switch-on delay Degree of protection Mounting position Connection Standards/regulations Housing material Inflammability class in acc. with UL 94 Screw connection solid/stranded/AWG	
Safety data as per ATEX	
Maximum voltage U_i	30 V
Maximum current I_i	100 mA
Maximum power P_i	750 mW
Maximum voltage U_o	5 V DC
Maximum current I_o	5.4 mA
Maximum power P_o	6.6 mW
Gas group	IIA IIB IIC
- Maximum external inductance L_o	100 [mH]
- Maximum external capacitance C_o	9.9 [µF]
Maximum ambient temperature	
Conformance/Approvals	
Conformance ATEX UL, USA/Canada Functional Safety (SIL)	

Technical data		
Pt, Ni (100, 500, 1000); min. measurement range 10 K B, C, D, E, J, K, L, N, R, S, T, U; min. measurement range 50 K/500 K		
10 Ω ... 400 Ω (min. measurement range 10 Ω) 10 Ω ... 2000 Ω (min. measurement range 100 Ω) -10 mV ... 75 mV (min. measurement range 5 mV) Yes, programmable		
4 mA ... 20 mA / 20 mA ... 4 mA ≤ 23 mA ≤ 630 Ω (At $U_V = 24$ V; $U_{supply} = 10$ V / 0.023 A) NE 43 ≤ 3.6 mA or ≥ 21 mA (adjustable, not for thermocouples)		
≤ 3.6 mA or ≥ 21 mA (adjustable) 3.8 mA ... 20.5 mA (linear increase/decrease)		
12 V DC ... 30 V DC < 3.5 mA < 2 s		
0.2 K (Pt 100, Ni 100), 0.5 K (Pt 500, Ni 500), 0.3 K (Pt 1000, Ni 1000) typ. 0.5 K (K, J, T, E, L, U), 1.0 K (N, C, D), 2.0 K (S, B, R) ± 0.1 Ω (10...400 Ω), ± 1.5 Ω (10...2000 Ω) ± 20 µV (-10...75 mV) 2 kV AC (50 Hz, 1 min.) 6 s IP00, IP66 (integrated in the connecting head) Connecting head in acc. with DIN 43729 form B Installation in connection head according to DIN 43729 form B NAMUR recommendation NE 21 Polycarbonate, PC V0 0.2 ... 1.75 mm ² / 0.2 ... 1.75 mm ² / 24 - 15		
30 V 100 mA 750 mW 5 V DC 5.4 mA 6.6 mW IIA IIB IIC 100 100 100 9.9 9.9 2 Category 1: T4 = 60°C, T5 = 50°C, T6 = 40°C Category 2: T4 = 85°C, T5 = 70°C, T6 = 55°C		
CE-compliant Ex II 1 G and II 2 G Ex ia IIC T6/T5/T4 cULus SIL 2		

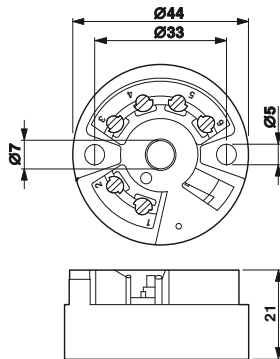

Description
MCR temperature transducer, smart, for resistance thermometers, thermocouples, resistance-type sensors, and voltage sensors

Ordering data		
Type	Order No.	Pcs./Pkt.
MCR-FL-HT-TS-I-EX	2864545	1

Temperature
Head-mounted temperature
transducer

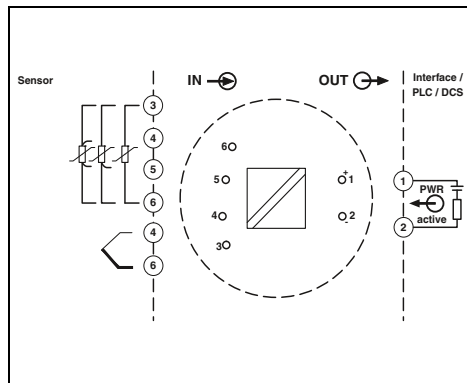
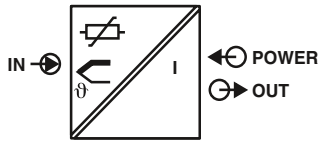

Loop-powered,
programmable



- Output loop-powered head-mounted temperature transducer
- Freely configurable
- Software available free of charge on the Internet
- For mounting in the connecting head, form B

Notes:
The devices are supplied with the standard configuration: Pt100 sensor, 0 to 100°C measuring range, 3-conductor connection.
The configuration software can be downloaded from the Internet: phoenixcontact.net/products.

Input data	
Resistance thermometers	
Thermocouple sensors	
Resistor	
Voltage	
Output data	
Output signal	
Load R_B	
Output signal with short-circuit	
Output signal with open circuit	
Measuring range overrange/underrange	
General data	
Supply voltage range	8 V DC ... 35 V DC
Current consumption	< 3.5 mA
Transmission error	Resistance thermometers Thermocouple sensors Resistance-type sensors Voltage sensor
Step response (10-90%)	< 2 s
Switch-on delay	6 s
Test voltage input/output	2 kV (50 Hz, 1 min.)
Degree of protection	IP00, IP66 (integrated in the connecting head)
Ambient temperature (operation)	-40 °C ... 85 °C
Mounting	any
Housing material	Polycarbonate, PC
Screw connection solid/stranded/AWG	0.2 ... 1.75 mm ² / 0.2 ... 1.75 mm ² / 24 - 15
Conformance/Approvals	
Conformance	
UL, USA/Canada	

Technical data		
Pt, Ni (100, 500, 1000); minimum measurement range 10 K : 2, 3, 4-wire		
B, C, D, E, J, K, L, N, R, S, T, U; minimum measurement range 50 K/500 K		
Resistance-type sensor from 10 Ω to 400 Ω and from 10 Ω to 2000 Ω; minimum measurement range 10 Ω/100 Ω -10 mV ... 75 mV (min. measurement range 5 mV)		
4 ... 20 mA / 20 ... 4 mA		
Max $(V_{supply} - 8 V) / 0.025 A$ (current output)		
≤ 3.6 mA or ≥ 21 mA (adjustable, not for thermocouples)		
≤ 3.6 mA or ≥ 21 mA (adjustable)		
≤ 20.5 mA / ≥ 3.8 mA (linear increase/decrease)		
General data		
8 V DC ... 35 V DC		
< 3.5 mA		
0.2 K (Pt 100, Ni 100), 0.5 K (Pt 500, Ni 500), 0.3 K (Pt 1000, Ni 1000)		
typ. 0.5 K (K, J, T, E, L, U), 1.0 K (N, C, D), 2.0 K (S, B, R)		
± 0.1 Ω (10...400 Ω), ± 1.5 Ω (10...2000 Ω)		
± 20 μV (-10...100 mV)		
< 2 s		
6 s		
2 kV (50 Hz, 1 min.)		
IP00, IP66 (integrated in the connecting head)		
-40 °C ... 85 °C		
any		
Polycarbonate, PC		
0.2 ... 1.75 mm ² / 0.2 ... 1.75 mm ² / 24 - 15		
Conformance/Approvals		
CE-compliant		
Class I, Div. 2, Groups A, B, C, D		

Description
MCR temperature transducer , for resistance thermometers, thermocouples, resistance-type sensors, and voltage sensors
Software adapter cable , 2.4 m long, with USB connection, for programming

Ordering data		
Type	Order No.	Pcs./Pkt.
MCR-FL-HT-T1	2864529	1
Accessories		
MCR-PAC-T-USB	2309000	1

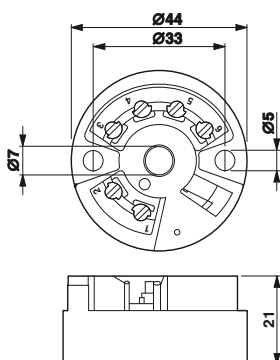

Temperature
Head-mounted temperature
transducer

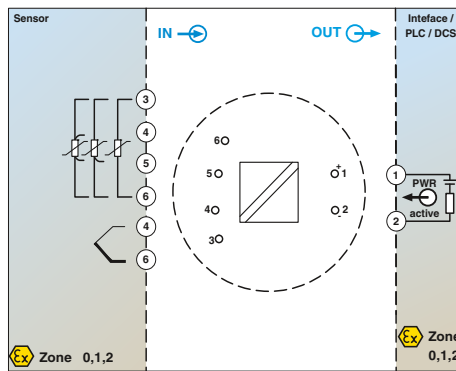
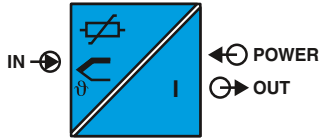

Loop-powered,
programmable



- 1-channel
- Loop-powered
- Input for resistance thermometers, thermocouples, and linear mV signals, Ex ia IIC
- 4 to 20 mA / 20 to 4 mA output
- Can be installed in Zone 0
- 2-way electrical isolation
- Configuration using software

Notes:
The devices are supplied with the standard configuration: Pt100 sensor, 0 to 100°C measuring range, 3-conductor connection.
The configuration software can be downloaded from the Internet: phoenixcontact.net/products.

Measuring input	
Resistance thermometers	
Thermocouple sensors	
Resistor	
Voltage	
Configuration	
Measuring output	
Output signal range	
Maximum output signal	
Load	
Line monitoring	
Short-circuit current	
Output current with open circuit	
Output current, measuring range overrange/underrange	
General data	
Supply voltage range	
Current consumption	
Step response (10-90%)	
Transmission error	
Resistance thermometers	0.2 K (Pt 100, Ni 100), 0.5 K (Pt 500, Ni 500), 0.3 K (Pt 1000, Ni 1000)
Thermocouple sensors	typ. 0.5 K (K, J, T, E, L, U), 1.0 K (N, C, D), 2.0 K (S, B, R)
Resistance-type sensors	± 0.1 Ω (10...400 Ω), ± 1.5 Ω (10...2000 Ω)
Voltage sensor	± 20 µV (-10...100 mV)
Test voltage input/output	2 kV AC (50 Hz, 1 min.)
Switch-on delay	6 s
Degree of protection	IP00, IP66 (integrated in the connecting head)
Mounting position	Connecting head in acc. with DIN 43729 form B
Connection	Installation in connection head according to DIN 43729 form B
Standards/regulations	NAMUR recommendation NE 21
Housing material	Polycarbonate, PC
Inflammability class in acc. with UL 94	V0
Screw connection solid/stranded/AWG	0.2 ... 1.75 mm ² / 0.2 ... 1.75 mm ² / 24 - 15
Safety data as per ATEX	
Maximum voltage Ui	30 V
Maximum current Ii	100 mA
Maximum power Pi	750 mW
Maximum voltage Uo	8.2 V DC
Maximum current Io	4.6 mA
Maximum power Po	9.35 mW
Gas group	IIB IIC
- Maximum external inductance Lo	[mH] 8.5 4.5
- Maximum external capacitance Co	[µF] 1.9 0.974
Maximum ambient temperature	Category 1: T4 = 60°C, T5 = 50°C, T6 = 40°C Category 2: T4 = 85°C, T5 = 70°C, T6 = 55°C
Conformance/Approvals	
Conformance	
ATEX	
UL, USA/Canada	

Technical data		
Pt, Ni (100, 500, 1000); min. measurement range 10 K		
B, C, D, E, J, K, L, N, R, S, T, U; min. measurement range 50 K/500 K		
10 Ω ... 400 Ω (min. measurement range 10 Ω)		
10 Ω ... 2000 Ω (min. measurement range 100 Ω)		
-10 mV ... 100 mV (min. measurement range 5 mV)		
Yes, programmable		
4 mA ... 20 mA / 20 mA ... 4 mA		
≤ 25 mA		
≤ 720 Ω (For U _v = 24 V; U _{supply} = 8 V / 0.025 A)		
NE 43		
≤ 3.6 mA or ≥ 21 mA (adjustable, not for thermocouples)		
≤ 3.6 mA or ≥ 21 mA (adjustable)		
3.8 mA ... 20.5 mA (linear increase/decrease)		
8 V DC ... 30 V DC		
< 3.5 mA		
< 2 s		
0.2 K (Pt 100, Ni 100), 0.5 K (Pt 500, Ni 500), 0.3 K (Pt 1000, Ni 1000)		
typ. 0.5 K (K, J, T, E, L, U), 1.0 K (N, C, D), 2.0 K (S, B, R)		
± 0.1 Ω (10...400 Ω), ± 1.5 Ω (10...2000 Ω)		
± 20 µV (-10...100 mV)		
2 kV AC (50 Hz, 1 min.)		
6 s		
IP00, IP66 (integrated in the connecting head)		
Connecting head in acc. with DIN 43729 form B		
Installation in connection head according to DIN 43729 form B		
NAMUR recommendation NE 21		
Polycarbonate, PC		
V0		
0.2 ... 1.75 mm ² / 0.2 ... 1.75 mm ² / 24 - 15		
30 V		
100 mA		
750 mW		
8.2 V DC		
4.6 mA		
9.35 mW		
IIB IIC		
[mH] 8.5 4.5		
[µF] 1.9 0.974		
Category 1: T4 = 60°C, T5 = 50°C, T6 = 40°C		
Category 2: T4 = 85°C, T5 = 70°C, T6 = 55°C		
CE-compliant		
Ex II 1 G Ex ia IIC T6/T5/T4		
cULus		

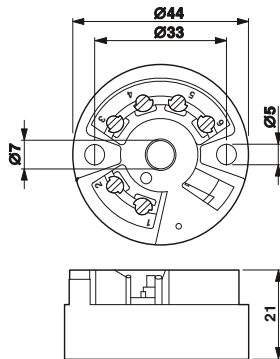

Description	
MCR temperature transducer, for resistance thermometers, thermocouples, resistance-type sensors, and voltage sensors	
Software adapter cable , 2.4 m long, with USB connection, for programming	

Ordering data		
Type	Order No.	Pcs./Pkt.
MCR-FL-HT-T-I-EX	2864532	1
Accessories		
MCR-PAC-T-USB	2309000	1

Temperature
Head-mounted temperature
transducer

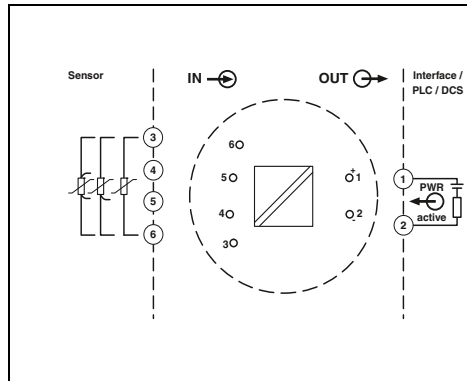
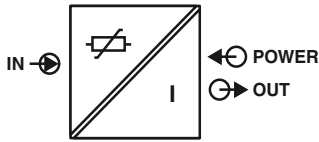

Loop-powered,
programmable



- Output loop-powered head-mounted temperature transducer for Pt 100 sensors
- Freely configurable
- Software available free of charge on the Internet
- For mounting in the connecting head, form B

Notes:

The devices are supplied with the standard configuration: Pt100 sensor, 0 to 100°C measuring range, 3-conductor connection.

The configuration software can be downloaded from the Internet: phoenixcontact.net/products.

Input data

Resistance thermometers

Output data

Output signal

Load R_B

Output signal with short-circuit

Output signal with open circuit

Measuring range overrange/underrange

General data

Supply voltage range

Current consumption

Transmission error

Step response (10-90%)

Switch-on delay

Degree of protection

Ambient temperature (operation)

Mounting

Housing material

Conformance/Approvals

Conformance

UL, USA/Canada

Resistance thermometers

Technical data

Pt 100 ; minimum measurement range 10 K : 2, 3, 4-wire

4 ... 20 mA / 20 ... 4 mA

Max ($V_{supply} - 10 V$) / 0.023 A (current output)

≤ 3.6 mA or ≥ 21 mA (adjustable)

≤ 3.6 mA or ≥ 21 mA (adjustable)

≤ 20.5 mA / ≥ 3.8 mA (linear increase/decrease)

10 V DC ... 35 V DC

< 3.5 mA

0.2 K

< 2 s

4 s

IP00, IP54 (integrated in the connecting head)

-40 °C ... 85 °C

any

Polycarbonate, PC

CE-compliant

Class I, Div. 2, Groups A, B, C, D

Ordering data

Description

MCR head-mounted temperature transducer, loop-powered

for Pt 100 resistance thermometer

Type

Order No.

Pcs./Pkt.

MCR-SL-HT-PT 100-I

2864516

1

Accessories

MCR-PAC-T-USB

2309000

1

Software adapter cable, 2.4 m long, with USB connection, for programming

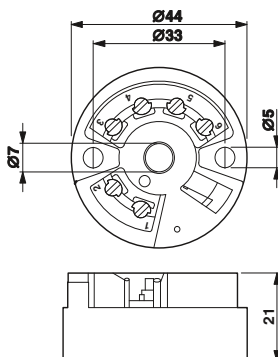

Accessories for head-mounted transducers

- 2 cable entries
- Aluminum with polyester coating
- For use with head-mounted transducers
- Display window in cover

new



Field housing for head-mounted transducers

General data		Technical data		
Housing material		Aluminum		
Description		Ordering data		
Field housing for head-mounted transducers, with display window and two cable entries		Type	Order No.	Pcs./Pkt.
		FA MCR-HT-FH	2908736	1
Wall fastening for FA MCR-HT-FH field housing		Accessories		
Pipe fastening for FA MCR-HT-FH field housing		FA MCR-HT-FH-WM	2908737	1
		FA MCR-HT-FH-PM	2908738	1

Accessories for head-mounted transducers

- For snapping onto the DIN rail
- For control cabinet installation of head-mounted transducers



Adapter for DIN rail mounting of
head-mounted transducers

Description	Ordering data		
	Type	Order No.	Pcs./Pkt.
Adapter for control cabinet installation of head-mounted transducers	MCR-DIN-RAIL-ADAPTER HT	2864671	1

Temperature
Temperature transducer

new

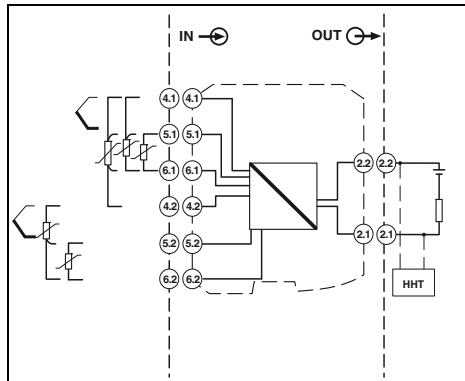
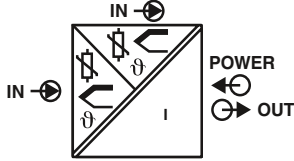

SIL
IEC 61508



Output loop-powered temperature transducer

Housing width 12.5 mm

- Loop-powered temperature transducer
- 2 universal inputs for RTD, TC, resistance-type sensors, and voltage sensors (mV)
- 4 to 20 mA output
- HART communication
- Freely configurable
- SIL 2/3
- For DIN rail mounting

Input data

Input signal (can be configured using DIP switches)
Input signal (can be configured using DIP switches)
Temperature range

Linear resistance measuring range

Input voltage range

Output data

Output signal
Maximum output signal
Load R_B

General data

Supply voltage range
Current consumption
Step response (0-99%)
Electrical isolation of input/output
Ambient temperature (operation)
Dimensions W/H/D
Push-in connection solid/stranded/AWG
Screw connection solid/stranded/AWG

Conformance/Approvals

Conformance

Technical data

Pt, Ni, Cu sensors: 2, 3, 4-wire : -
A, B, C, D, E, J, K, L, N, R, S, T, U
-250 °C ... 2500 °C (Range depending on the sensor type)

10 Ω ... 2000 Ω (Minimum measuring span: 10 Ω)

-20 mV ... 100 mV

4 ... 20 mA / 20 ... 4 mA
22.5 mA
($U_L - 11 V$) / 0.023 A

12 V DC ... 42 V DC
3.5 mA
0.8 s (TC)
2 kV AC
-40 °C ... 85 °C
12.5 / 99 / 114.5 mm
0.2 ... 1.5 mm² / 0.2 ... 1.5 mm² / 24 - 16
0.2 ... 2.5 mm² / 0.2 ... 2.5 mm² / 24 - 14

CE-compliant

Ordering data

Description

Output loop-powered temperature transducer, for
RTD, TC, resistance-type sensors, and voltage sensors (mV)

Screw connection
Push-in connection

Type	Order No.	Pcs./Pkt.
MACX MCR-TS-I-OLP	2908662	1
MACX MCR-TS-I-OLP-SP	2908664	1

Software adapter cable, 2.4 m long, with
USB connection, for programming

Accessories

MCR-PAC-T-USB	2309000	1
---------------	---------	---

Temperature
Temperature transducer

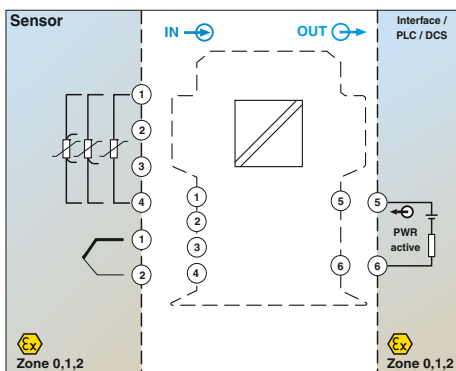
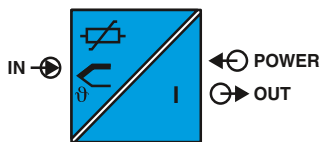

Loop-powered, programmable

ERAC

Ex:
Housing width 12.5 mm

Technical data

Measuring input	Resistance thermometers
	Thermocouple sensors
	Resistor
	Voltage
	Configuration
Measuring output	Output signal range
	Maximum output signal
	Load
	Line monitoring
	Short-circuit current

Output current with open circuit
Output current, measuring range overrange/underrange

General data	Supply voltage range	12 V DC ... 30 V DC
	Current consumption	< 3.5 mA
	Step response (10-90%)	< 2 s
	Transmission error	Resistance thermometers Thermocouple sensors Resistance-type sensors Voltage sensor

Test voltage input/output	Switch-on delay	Standards/regulations	Housing material	Inflammability class in acc. with UL 94	Dimensions W/H/D	Connection method	Screw connection solid/stranded/AWG
Safety data as per ATEX	Maximum voltage U_i	Maximum current I_i	Maximum power P_i	Maximum voltage U_o	Maximum current I_o	Maximum power P_o	Gas group
	- Maximum external inductance L_o	[mH]	- Maximum external capacitance C_o	[µF]	Maximum ambient temperature		

Conformance/Approvals	Conformance	ATEX	UL, USA/Canada	Functional Safety (SIL)
-----------------------	-------------	------	----------------	-------------------------

Pt, Ni (100, 500, 1000); min. measurement range 10 K
B, C, D, E, J, K, L, N, R, S, T, U; min. measurement range 50 K/500 K
10 Ω ... 400 Ω (min. measurement range 10 Ω)
10 Ω ... 2000 Ω (min. measurement range 100 Ω)
-10 mV ... 100 mV (min. measurement range 5 mV)
Yes, programmable
4 mA ... 20 mA / 20 mA ... 4 mA
≤ 23 mA
≤ 520 Ω (At $U_V = 24$ V; $U_{supply} = 12$ V / 0.023 A)
NE 43
≤ 3.6 mA or ≥ 21 mA (adjustable, not for thermocouples)
≤ 3.6 mA or ≥ 21 mA (adjustable)
3.8 mA ... 20.5 mA

12 V DC ... 30 V DC	< 3.5 mA	< 2 s	0.2 K (Pt 100, Ni 100), 0.5 K (Pt 500, Ni 500), 0.3 K (Pt 1000, Ni 1000)
typ. 0.5 K (K, J, T, E, L, U), 1.0 K (N, C, D), 2.0 K (S, B, R)	± 0.1 Ω (10...400 Ω), ± 1.5 Ω (10...2000 Ω)	± 20 µV (-10...100 mV)	2 kV AC (50 Hz, 1 min.)
4 s	NAMUR recommendation NE 21	Polyamide PA non-reinforced	V0
12.5 / 99 / 114.5 mm	Screw connection	0.2 ... 2.5 mm ² / 0.2 ... 2.5 mm ² / 24 - 14	
MCR-FL-TS-LP-I-EX	MCR-FL-T-LP-I-EX		
30 V	30 V		
100 mA	100 mA		
750 mW	750 mW		
5 V DC	4.4 V DC		
5.9 mA	9.6 mA		
7.2 mW	10.6 mW		
IIA IIB IIC	IIA IIB IIC		
100 100 100	100 100 100		
10 10 2	12 12 2.4		
T4 = 85 °C, T5 = 70 °C, T6 = 55 °C	T4 = 85 °C, T5 = 65 °C, T6 = 50 °C		

CE-compliant	CE-compliant
II 2(1) G Ex ia IIC T6	II 2(1) G Ex ia IIC T4...T6
cULus	cULus
SIL 2	-

Ordering data

Description	MCR temperature transducer, for resistance thermometers, thermocouples, resistance-type sensors, and voltage sensors
HART-compatible	

Type	Order No.	Pcs./Pkt.
MCR-FL-TS-LP-I-EX	2864587	1
MCR-FL-T-LP-I-EX	2864574	1

- 1-channel
- Loop-powered
- Input for resistance thermometers, thermocouples, and linear mV signals, Ex ia IIC
- 4 to 20 mA / 20 to 4 mA output
- Can be installed in Zone 1
- 2-way electrical isolation
- HART-capable (MCR-FL-TS-LP-I-EX)
- Configuration using software

Notes:
The devices are supplied with the standard configuration: Pt100 sensor, 0 to 100°C measuring range, 3-conductor connection.
To configure the MCR-FL-TS-LPI-EX HART-capable device (2864587), you need a HART modem.
The configuration software can be downloaded from the Internet: phoenixcontact.net/products.

Temperature
Temperature transducer

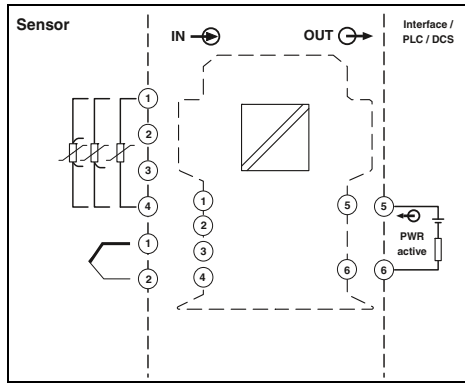
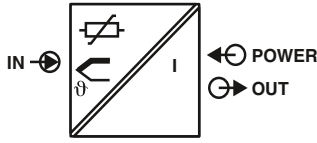

Loop-powered, programmable



Housing width 12.5 mm

- Output loop-powered temperature transducer
- Freely configurable
- Software available free of charge on the Internet

Notes:
The devices are supplied with the standard configuration: Pt100 sensor, 0 to 100°C measuring range, 3-conductor connection.
The configuration software can be downloaded from the Internet: phoenixcontact.net/products.

Input data	
Resistance thermometers	
Thermocouple sensors	
Resistor	
Voltage	
Output data	
Output signal	
Load R_B	
Output signal with short-circuit	
Output signal with open circuit	
Measuring range overrange/underrange	
General data	
Supply voltage range	12 V DC ... 35 V DC
Current consumption	< 3.5 mA
Transmission error	Resistance thermometers 0.2 K (Pt 100, Ni 100), 0.5 K (Pt 500, Ni 500), 0.3 K (Pt 1000, Ni 1000) Thermocouple sensors typ. 0.5 K (K, J, T, E, L, U), 1.0 K (N, C, D), 2.0 K (S, B, R) Resistance-type sensors $\pm 0.1 \Omega$ (10...400 Ω), $\pm 1.5 \Omega$ (10...2000 Ω) Voltage sensor $\pm 20 \mu V$ (-10...100 mV)
Step response (10-90%)	< 2 s
Switch-on delay	4 s
Test voltage input/output	2 kV (50 Hz, 1 min.)
Degree of protection	IP20
Ambient temperature (operation)	-40 °C ... 85 °C
Mounting	any
Housing material	Polyamide PA non-reinforced
Dimensions W/H/D	12.5 / 99 / 114.5 mm
Screw connection solid/stranded/AWG	0.2 ... 2.5 mm ² / 0.2 ... 2.5 mm ² / 24 - 14
Conformance/Approvals	
Conformance	CE-compliant
UL, USA/Canada	Class I, Div. 2, Groups A, B, C, D

Technical data

Pt, Ni (100, 500, 1000); minimum measurement range 10 K : 2, 3, 4-wire
B, C, D, E, J, K, L, N, R, S, T, U; minimum measurement range 50 K/500 K
Resistance-type sensor from 10 Ω to 400 Ω and from 10 Ω to 2000 Ω ; minimum measurement range 10 Ω /100 Ω
-10 mV ... 100 mV (min. measurement range 5 mV)
4 ... 20 mA / 20 ... 4 mA
Max ($V_{supply} - 12 V$) / 0.023 A (current output)
≤ 3.6 mA or ≥ 21 mA (adjustable, not for thermocouples)
≤ 3.6 mA or ≥ 21 mA (adjustable)
≤ 20.5 mA / ≥ 3.8 mA (linear increase/decrease)

Description
MCR temperature transducer, loop-powered for resistance thermometers, thermocouples, resistance-type sensors, and voltage sensors
Software adapter cable, 2.4 m long, with USB connection, for programming

Ordering data

Type	Order No.	Pcs./Pkt.
MCR-FL-T-LP-I	2864561	1
MCR-FL-T-LP-I-EX	2864574	1

Accessories

MCR-PAC-T-USB	2309000	1
----------------------	----------------	---

Temperature
Temperature transducer

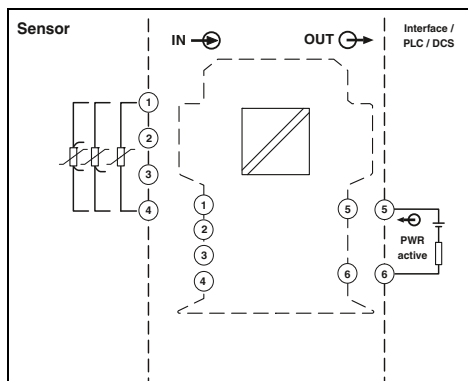
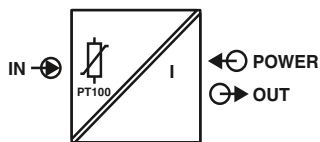

Loop-powered,
programmable

UL US ENEC

Ex:

Housing width 12.5 mm

Technical data

Pt 100 ; minimum measurement range 10 K : 2, 3, 4-wire

4 ... 20 mA / 20 ... 4 mA
Max ($V_{supply} - 12 V$) / 0.023 A (current output)

≤ 3.6 mA or ≥ 21 mA (adjustable)
 ≤ 3.6 mA or ≥ 21 mA (adjustable)
 ≤ 20.5 mA / ≥ 3.8 mA (linear increase/decrease)

12 V DC ... 35 V DC
< 3.5 mA
0.2 K
< 2 s
4 s
2 kV (50 Hz, 1 min.)
IP20
-40 °C ... 85 °C
any
Polyamide PA non-reinforced
12.5 / 99 / 114.5 mm
0.2 ... 2.5 mm² / 0.2 ... 2.5 mm² / 24 - 24

CE-compliant
Class I, Div. 2, Groups A, B, C, D

Ordering data

Input data	Resistance thermometers
Output data	Output signal Load R_B
	Output signal with short-circuit Output signal with open circuit Measuring range overrange/underrange
General data	Supply voltage range Current consumption Transmission error Step response (10-90%) Switch-on delay Test voltage input/output Degree of protection Ambient temperature (operation) Mounting Housing material Dimensions W/H/D Screw connection solid/stranded/AWG
	Resistance thermometers
Conformance/Approvals	
Conformance	UL, USA/Canada

Description	MCR temperature transducer, loop-powered for Pt 100 resistance thermometer
--------------------	---

Type	Order No.	Pcs./Pkt.
MCR-SL-PT100-LP-I	2864558	1

- Two-wire transmitter for Pt 100 resistance thermometers
- Freely programmable via MCR/PI-CONF-WIN

Notes:

The devices are supplied with the standard configuration: Pt100 sensor, 0 to 100°C measuring range, 3-conductor connection.

You can implement your own measuring range settings, linearization, and characteristic curve adjustments. To do so, you need the MCR-PAC-T-USB programming adapter as well as the MCR/PI-CONF-WIN configuration software.



Monitoring

Energy and power measurement

EMpro energy meters measure, analyze, and communicate electrical system parameters.

Monitoring software ensures efficient energy and power measurement.

Stand-alone data loggers are the complete package for decentralized data acquisition.

PSK sensors acquire the operating pressure of gaseous media.

PSK meters record compressed air consumption.

Current measurement

PACT current transformers convert currents up to 4000 A into secondary currents of 1 and 5 A.

MCR current transducers convert currents into standard analog signals.

Monitoring and diagnostics

The SOLARCHECK modular monitoring system is used for string monitoring in photovoltaic systems.

EV Charge Control is the charging controller used to charge electric vehicles on the AC mains according to IEC 61851-1.

EMD monitoring relays detect and indicate deviations in important system parameters at an early stage.

ETD time relays are used for straightforward time control functions.

Diode modules, lamp testing modules, and EMG display modules allow industrial use of simple components such as diodes - with professional housing and connection technology.

Product range overview

Product overview	200
Energy and power measurement	202
EMpro energy meters	208
EMpro function and communication modules	210
Accessories	213
Software for usage data acquisition	214
Complete packages for data logging	215
Pressure sensor and compressed air meters	216
Current measurement	
Current transformers	220
Current transformer selection guide	222
PACT current transformers	223
Accessories for PACT current transformers	233
PACT RCP current transformers for retrofitting	234
Current transducers	240
Accessories for current transducers	251
Monitoring and diagnostics	
Solar system monitoring	252
EMD electronic monitoring relays	260
ETD electronic time relays	272
Diode modules, lamp testing modules, EMG display modules	280

Monitoring

Product overview

Energy and power measurement



EMpro energy meters for front-panel installation Page 208



EMpro energy meters for DIN rail mounting Page 209



Function and communication modules for EMpro Page 210



DIN rail adapters for EMpro Page 213

Current transformers



PACT busbar current transformers Page 222



PACT window-type current transformers Page 224



PACT winding current transformers Page 232



Mounting accessories, shock protection Page 233

Voltage measurement



MCR voltage transducers for AC and DC voltages up to 660 V Page 250



Accessories
Configuration software and USB adapter cable Page 251

Solar system monitoring



SOLARCHECK
Photovoltaic string monitoring Page 256

Time relays



ETD-BL
Ultra-narrow time relays Page 276



ETD
Multifunctional time relays Page 278

Function modules



EMG
Diode modules, lamp testing modules, display modules Page 280

Lightning monitoring system



Lightning monitoring system
See Catalog 4



Software for usage data acquisition
Page 214



Complete packages for data logging
Page 215



Compressed air meters
Page 216



Pressure sensor with IO-Link
Page 218

Current measurement



PACT RCP... current transformers for retrofitting
Page 236



MCR current transducers for AC/DC and distorted currents
Page 240



MCR current transducer for sinusoidal and distorted AC currents
Passive, up to 5 A
Page 246



MCR current protector for AC currents, sinusoidal up to 16 A
Page 249

Charging technology for E-Mobility



AC charging controllers for private and commercial applications
See Catalog 2



Locking release module for mains failure
See Catalog 2

Monitoring relays



EMD-BL
Compact monitoring relays
Page 262

HMIs



HMIs
See Catalog 6

Signal towers



Signal towers
See Catalog 6



Energy costs at a glance

Within industry, energy is viewed as a variable cost factor. As a result, lower energy costs are becoming increasingly important in terms of providing companies with a major competitive advantage in the areas of production, process, and industrial engineering.

Alongside energy consumption, the quality of the energy supplied, the reliability of supply, and effective system utilization also play an important role in ensuring profitability. This calls for continuous measurement and analysis of all sources of energy.

Advantages of energy data acquisition

Continuously recorded energy flow provides the basis for a target-oriented energy management system.

Access comprehensive information regarding the characteristic electrical data of your machinery and benefit from the advantages of this:

- Reduce your energy costs by identifying potential energy savings.
- Optimize your system capacity: through intelligent switching of system parts, uniform network load, and reduced harmonics.
- Reduce peak loads using forward-looking trend calculation and load management.
- Safeguard your production processes and minimize downtimes by continuously monitoring important system parameters.

Measurement – monitoring – communication

Efficient energy management – network-capable EMpro energy meters can be used to acquire and monitor the characteristic electrical data of your machines and systems.

They can be freely extended with communication modules and function modules, enabling your energy meters to keep pace with your growing requirements. Future-proof planning and investment is therefore ensured.



The communication expert

The EMpro MA600 is capable of performing all measurement tasks associated with power supply applications up to 700 V AC.

- From simple current and power measurement to detection of harmonics including spectral analysis
- Flexible integration into Ethernet, PROFIBUS or RS-485 networks
- Remote access via web server
- Optional DIN rail adapter for DIN rail mounting
- Can be extended with communication modules and function modules



The universal solution on the front panel

The EMpro MA400 performs standard measuring tasks up to 519 V AC.

- Optional DIN rail adapter for DIN rail mounting
- Communication module for integration into RS-485 networks (Modbus/RTU)
- Function module for pulse or alarm output



The measuring device with RS-485 communication

The EMpro MA250 performs standard measuring tasks up to 519 V AC.

- DIN rail device
- With pulse or alarm output
- Integrated RS-485 communication (Modbus/RTU)

The measuring device with pulse output

The EMpro MA200 is ideal for simple measuring tasks up to 519 V AC.

- DIN rail device
- With pulse or alarm output



Controller solution for usage data acquisition

The EMlog software provides an efficient solution for recording energy data relating to heat, cold, air, and electricity when used in conjunction with the ILC 191 ME/AN modular Inline controller. This allows you to keep an eye on your resources and manage the consumption levels of your machines and systems.



Sensors and meters

Use of resources at a glance - determine all relevant states using sensors and meters.

- Detailed procurement measurement, thanks to precise sensor and meter technology
- Intelligent sensor communication, thanks to IO-Link technology



Inline power measurement terminal

The Inline power measurement terminal enables analysis of AC networks.

- For measuring current, voltage, and power, as well as identifying distortion and harmonics
- The power measurement terminal can be found in Catalog 6, Control technology, I/O systems, and network structure.

Monitoring

Energy and power measurement

Energy meters

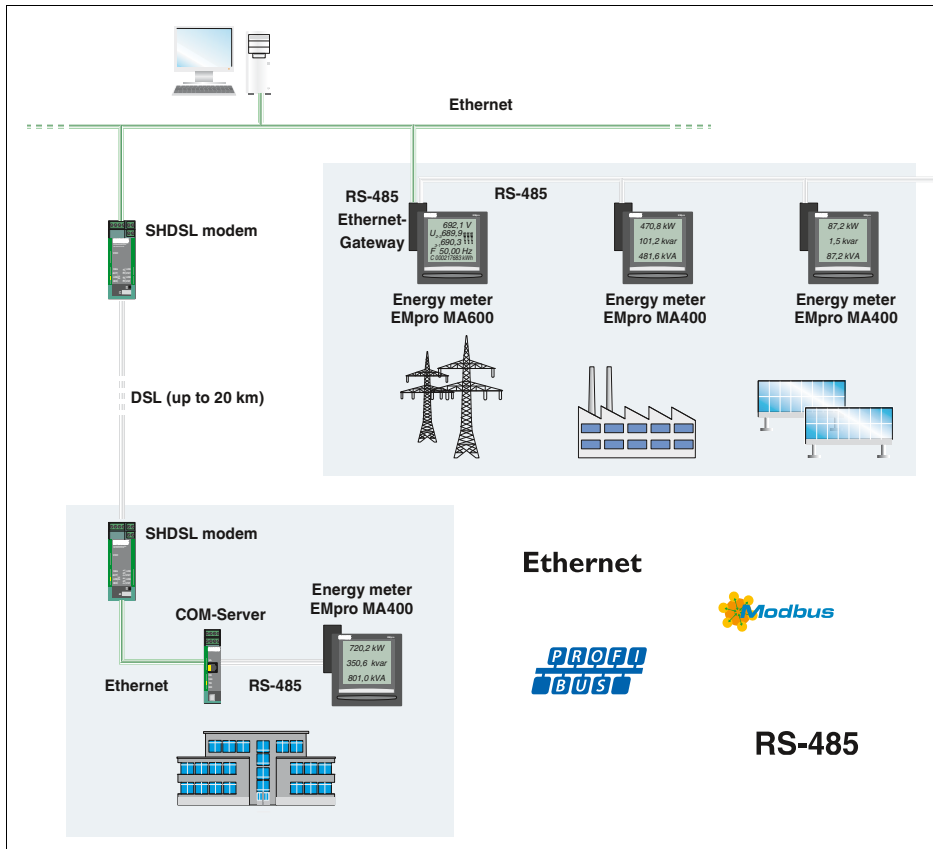

Measurement – monitoring – communication

In order to achieve efficient energy management, all energy data that has been determined is recorded and analyzed centrally in the control center.

For data transmission, integrate the EMpro measuring devices flexibly into your network structures.

The network components from Phoenix Contact offer interference-free and high-performance communication of energy data, even in harsh industrial environments:

- Copper-based and fiber optic data transmission
- Ethernet and modem communication
- Industrial wireless transmission



Direct access to measured values

Analyze your system parameters quickly on site. At the touch of a button, you can access precisely those measured values that are of relevance.

You can also use the user-friendly web server function to request measured values directly from the control center.



Planning reliability and investment security

Stay flexible. EMpro extension modules, function modules, and communication modules enable you to extend your EMpro measuring devices at any time:

- Digital inputs and outputs
- Pulse outputs
- Analog outputs
- Communication interfaces
- Measured data storage



Remote access to multiple measuring devices - with just one IP address

The web server that has been integrated into the Ethernet communication modules allows you to conveniently configure key parameters online. It also allows remote access to key electrical characteristics such as current, voltage, power, energy, and harmonics.

Selection guide

You can easily select the right device for your application by referring to the table below:



Product type	EMpro MA600	EMpro MA400	EMpro MA200/250
	2901366 EEM-MA600	2901364 EEM-MA400	2901362 EEM-MA200
	2902352 EEM-MA600-24DC		2901363 EEM-MA250
Voltages			
Voltage measurement direct	Up to 700 V	Up to 519 V	Up to 519 V
Voltage transducers	Up to 500 kV		
Voltages U12, U23, U31, V1, V2, V3	•	•	•
Maximum mean value	•		
Mean value	•		
Currents			
Current measurement	Direct up to 6 A or current transformer	Current transformers	Current transformers
Currents I1, I2, I3	•	•	•
Neutral conductor current IN (calculation)	•	•	•
Maximum mean value	•	•	•
Mean value	•		
Frequency			
F	•	•	•
Maximum mean value	•		
Mean value	•		
Power			
Real power, reactive power, apparent power: ΣP (+/-), ΣQ (+/-), ΣS (+/-)	•	•	•
P, Q, S per phase	•	•	•
Maximum mean value	•	•	•
Mean value	•		
Trend performances	•		
Power factor			
ΣPF	•	•	•
PF per phase	•	•	•
Metering			
Real energy (kWh)	kWh+/kWh-	kWh+	kWh+
Reactive energy (kvarh)	kvarh+/kvarh-	kvarh+	kvarh+
Apparent energy (kVAh)	kVAh		
Multi-tariff meter			2
Operating hours	•	•	•
Accuracy class (EN62053-22)	0.5 S	0.5 S	0.5 S
Harmonics analysis			
Distortion factor THD I/U/V	Up to 63rd	Up to 51st	Up to 51st
Spectral analysis	Up to 63rd		
Functions			
Temperature recording			•
Digital input			•
Function modules (optional)			
1 pulse or alarm output		2904314 EEM-IMP-MA400	Integrated
2 pulse outputs	2904313 EEM-IMP-MA600		
2 digital inputs, 2 digital outputs	2901371 EEM-2DIO-MA600		
2 analog outputs	2901475 EEM-2AO-MA600		
Memory	2901370 EEM-MEMO-MA600		
Communication modules (optional)			
RS-485 (Modbus/RTU)	2901367 EEM-RS485-MA600	2901365 EEM-RS485-MA400	Integrated (MA250 only)
D-SUB (PROFIBUS)	2901418 EEM-PB12-MA600		
Ethernet gateway (Modbus/TCP/RTU) with integrated web server	2901374 EEM-ETH-RS485-MA600		
Ethernet (Modbus/TCP) with integrated web server	2901373 EEM-ETH-MA600		

Key

I1, I2, I3 Conductor currents
 IN Neutral conductor current
 U12, U23, U31 Phase conductor voltages
 V1, V2, V3 Phase/N conductor voltages

P Real power
 Q Reactive power
 S Apparent power
 PF Power factor

THD Total harmonic distortion
 Σ Total values

Monitoring

Energy and power measurement

Transmit electrical characteristics wirelessly and easily

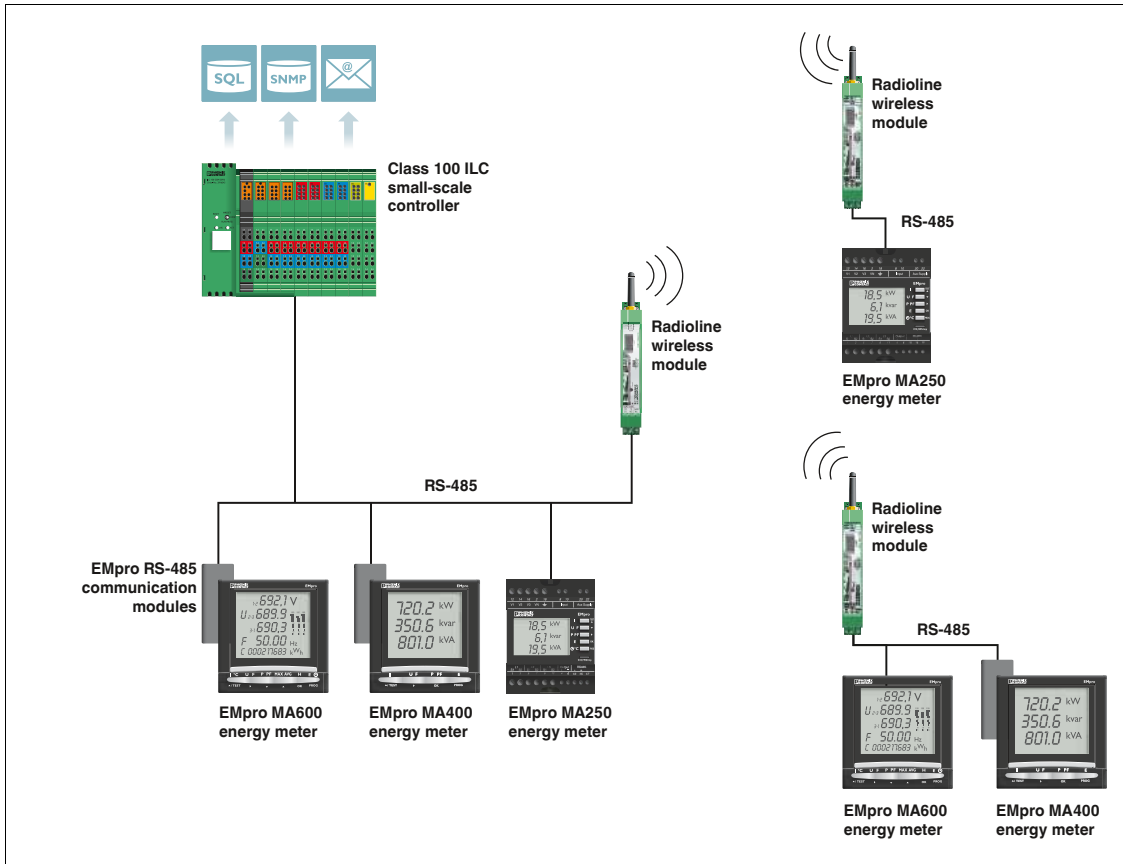

Direct connection from the PC to the EMpro MA600

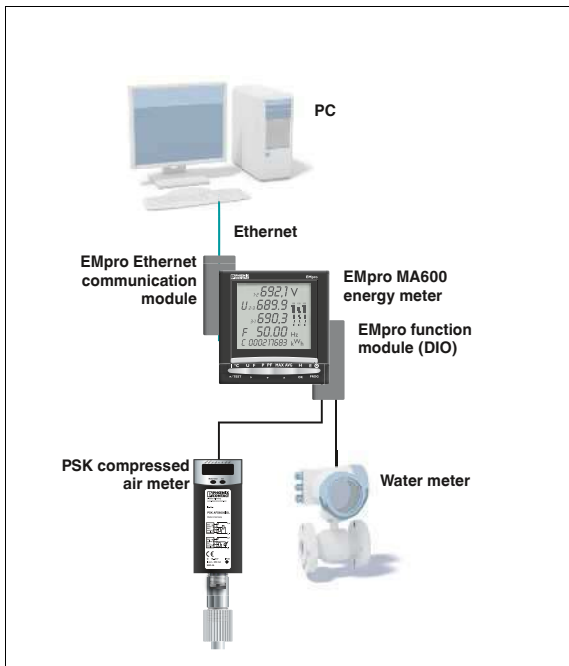

Connect up to six external meters to one EMpro MA600

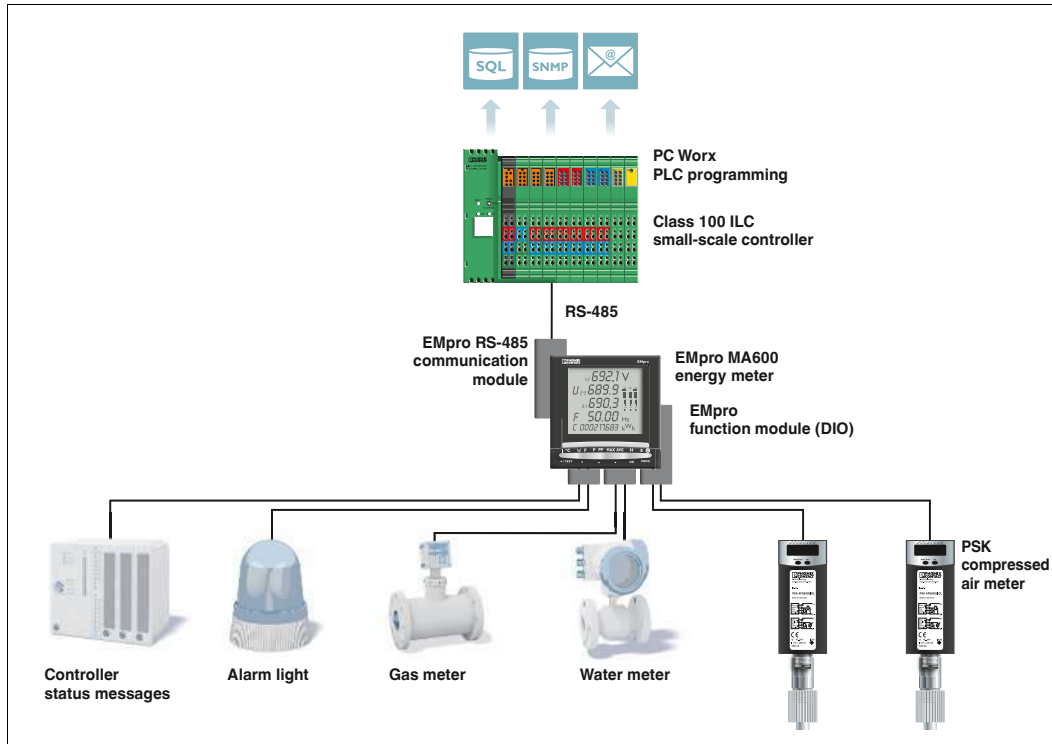

Easy machine monitoring - communicate electrical characteristics via Modbus/RTU

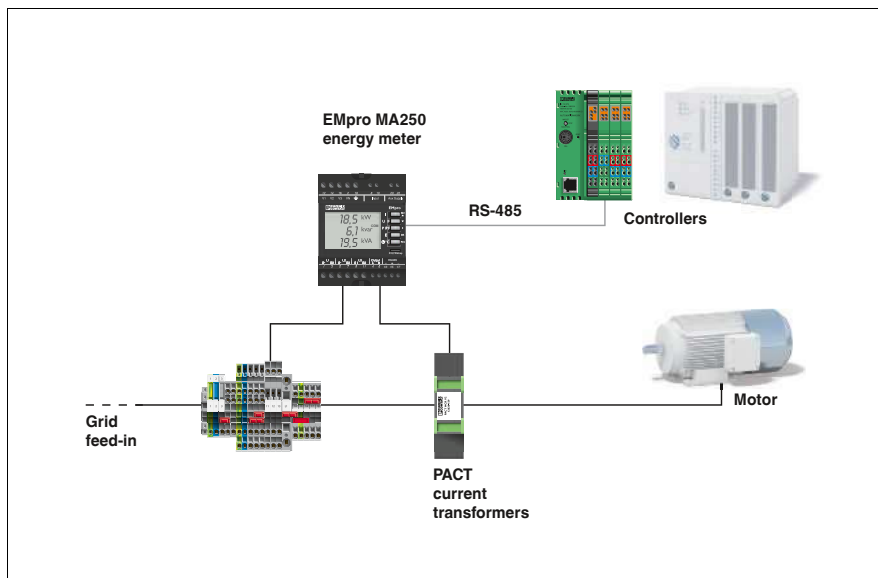

Monitoring

Energy and power measurement

Energy meters

EMpro energy meters are capable of acquiring, monitoring, and displaying all electrical system and machine parameters locally.

EEM-MA600

- Can be extended with function and communication modules
- Remote access via web server, integrated into Ethernet communication module
- Acquisition of individual harmonic components up to 63rd order
- Trend calculation for active and reactive power

EEM-MA400

- Can be extended with output module
- Can be extended with RS-485 communication module (JBUS/MODBUS)
- Acquisition of total harmonic content up to harmonic of 51st order

EEM-MA250

- Two-tariff measurement via digital input
- Pulse or alarm output
- RS-485 interface (JBUS/MODBUS)

EEM-MA200

- Two-tariff measurement via digital input
- Pulse or alarm output

EEM-MKT-DRA

- DIN rail adapter for the EEM-MA600 and EEM-MA400 front panel devices see page 213.

Notes:
The EEM-MA600-24DC energy meter (Order No. 2902352) is not CE-compliant.



Measuring voltage up to 700 V AC, can be extended with function and communication modules



Input data	Measuring principle Acquisition of harmonics Measured value Voltage measuring input V1, V2, V3 Input voltage range
Accuracy	Current measuring input I1, I2, I3 Input current range (Via external transformers)
Overload capacity	Operate threshold Accuracy
Power measurement	Measuring range
Accuracy	Active energy (IEC 62053-22) Reactive power (IEC 62053-23)
Digital input	Voltage input signal
Switching output	Output description Maximum switching voltage Current carrying capacity
Serial port	Output description Serial transmission speed
Display	Type Measuring rate
General data	Supply voltage range Nominal power consumption Degree of protection Ambient temperature (operation) Dimensions W/H/D Installation depth with extension module Connection cross section (solid / stranded / AWG)
EMC note	Voltage and other connections Current connection
Conformance/Approvals	Conformance

Technical data	
True r.m.s. value measurement up to 63rd harmonic AC sine (50/60 Hz)	
18 V AC ... 700 V AC (Phase/Phase) 11 V AC ... 404 V AC (Phase/neutral conductor) 500 kV AC (Primary, via external voltage transducers) Secondary: 60, 100, 110, 115, 120, 173, 190 V AC	
0.2 %	9999 A (primary) 1 A and 5 A, secondary 6 A (Permanent) 10 mA
0.2 %	0 MW ... 8000 MW / 0 Mvar ... 8000 Mvar / 0 MVA ... 8000 MVA
0.5 %	Class 0.5 S Class 2
Via function module	
Via function module -	
Via communication module -	
LCD display, backlighting 1 s	
110 V AC ... 400 V AC ±10 % 120 V DC ... 350 V DC (± 20 %) 10 VA 20 VA (with max. number of extension modules) IP52 (front), IP30 (back) -10 °C ... 55 °C (14 °F to 131 °F) 96 / 96 / 82 mm 80 mm	
0.5 ... 2.5 mm ² / 0.5 ... 2.5 mm ² / 20 - 14 0.5 ... 6 mm ² / 0.5 ... 6 mm ² / 20 - 8 Class A product, see page 605	
CE-compliant	

Description
Energy meter , for installation in front panel
Energy meter , for front-panel installation, 24 V DC
Energy meter , for mounting on a DIN rail

Ordering data		
Type	Order No.	Pcs./Pkt.
EEM-MA600	2901366	1
EEM-MA600-24DC	2902352	1



Measuring voltage up to 519 V AC, can be extended with RS-485 interface and output module



Measuring voltage up to 519 V AC, DIN rail installation, also with RS-485 interface



Technical data
True r.m.s. value measurement up to 51st harmonic AC sine (50/60 Hz)
50 V AC ... 500 V AC (Phase/Phase) 28 V AC ... 289 V AC (Phase/neutral conductor)
0.2 %
9999 A (primary) 5 A (secondary) 6 A (Permanent) 5 mA 0.2 %
0 MW ... 11 MW / 0 Mvar ... 11 Mvar / 0 MVA ... 11 MVA
0.5 % Class 0.5 S Class 2
-
Via function module -
Via communication module -
LCD display, backlighting 1 s
110 V AC ... 400 V AC $\pm 10\%$ 120 V DC ... 350 V DC ($\pm 20\%$) 5 VA 10 VA (with max. number of extension modules) IP52 (front), IP30 (back) -10 °C ... 55 °C (14 °F to 131 °F) 96 / 96 / 82 mm 80 mm
0.5 ... 2.5 mm ² / 0.5 ... 2.5 mm ² / 20 - 14 0.5 ... 6 mm ² / 0.5 ... 6 mm ² / 20 - 8 Class A product, see page 605
CE-compliant

Technical data
True r.m.s. value measurement up to 51st harmonic AC sine (50/60 Hz)
50 V AC ... 519 V AC (Phase/Phase) 28 V AC ... 300 V AC (Phase/neutral conductor)
0.2 %
9999 A (primary) 5 A (secondary) 6 A (Permanent) 5 mA 0.2 %
0 kW ... 9999 kW / 0 kvar ... 9999 kvar / 0 kVA ... 9999 kVA
0.5 % Class 0.5 S Class 2
230 V AC $\pm 10\%$ (Tariff switchover: e.g., day/nighttime tariff)
Transistor output, active 30 V DC 27 mA
EEM-MA250 EEM-MA200 Modbus RTU/JBUS RS-485 None 2.4 ... 38.4 kbps
LCD display, backlighting 1 s
110 V AC ... 277 V AC -10 % ... +15 % 5 VA IP51 (front), IP20 (back) -10 °C ... 55 °C (14 °F to 131 °F) 72 / 90 / 64 mm
0.5 ... 2.5 mm ² / 0.5 ... 2.5 mm ² / 20 - 14 0.5 ... 4 mm ² / 0.5 ... 4 mm ² / 20 - 10 Class A product, see page 605
CE-compliant

Ordering data		
Type	Order No.	Pcs./ Pkt.
EEM-MA400	2901364	1

Ordering data		
Type	Order No.	Pcs./ Pkt.
EEM-MA250	2901363	1
EEM-MA200	2901362	1

Monitoring

Energy and power measurement

Function modules

Plug-in function modules for the EEM-MA600 energy meter.

EEM-2DIO-MA600

- Two digital inputs and outputs
- Configurable threshold values

EEM-2AO-MA600

- Two analog outputs
0 to 20 mA/4 to 20 mA, configurable



Two digital inputs, two digital outputs



Two analog outputs

	Technical data	Technical data				
Digital input						
Voltage input signal	10 V DC ... 30 V DC	-				
Input pulse length	10 ms	-				
Output						
Output description	Relay output	Current output				
Maximum switching voltage	250 V AC/DC	-				
General data						
Supply voltage	9 V (via EEM-MA600)	9 V (via EEM-MA600)				
Degree of protection	IP20	IP20				
Ambient temperature (operation)	-10 °C ... 55 °C (14 °F to 131 °F)	-10 °C ... 55 °C (14 °F to 131 °F)				
EMC note	Class A product, see page 605	Class A product, see page 605				
Conformance/Approvals						
Conformance	CE-compliant	CE-compliant				
UL, USA/Canada	UL 61010-1	UL 61010-1				
	Ordering data	Ordering data				
Description	Type	Order No.	Pcs./Pkt.	Type	Order No.	Pcs./Pkt.
Function module (for EEM-MA600)	EEM-2DIO-MA600	2901371	1	EEM-2AO-MA600	2901475	1

Function module

Plug-in function module for the EEM-MA600 energy meter

EEM-MEMO-MA600

- Stores P (+/-) and Q (+/-) with an internal or external synchronization pulse of 5, 8, 10, 20, 30 or 60 minutes, e.g., synchronization pulse of 15 minutes over 45 days
- Stores the last ten alarms with time stamp (2DIO function module necessary)
- Stores the last smallest and largest instantaneous values for voltages, currents, frequency, actual power, reactive power, entire harmonic distortion
- Stores the mean values of the cable voltage, line to line voltage and frequency (maximum 60 days)
- Stores undervoltage, surge voltage, and phase failure
- Cannot be combined with PROFIBUS communication module



Memory module

	Technical data		
Digital input			
Voltage input signal	10 V DC ... 30 V DC		
General data			
Supply voltage	9 V (via EEM-MA600)		
Memory size	512 kByte		
Degree of protection	IP20		
Ambient temperature (operation)	-10 °C ... 55 °C (14 °F to 131 °F)		
EMC note	Class A product, see page 605		
Conformance/Approvals			
Conformance	CE-compliant		
UL, USA/Canada	UL 61010-1		
	Ordering data		
Description	Type	Order No.	Pcs./Pkt.
Function module (for EEM-MA600) Memory module	EEM-MEMO-MA600	2901370	1

Communication modules

EEM-PB 12-MA600

- PROFIBUS DP, with transmission speeds of 12 Mbps

EEM-RS485-MA...

- JBUS / Modbus/RTU



Modbus/RTU (RS-485)



PROFIBUS

	Technical data			Technical data		
Serial port						
Output description	Modbus RTU/JBUS RS-485			PROFIBUS DP		
Serial transmission speed	2.4 ... 38.4 kbps			12 Mbps		
General data						
Supply voltage	9 V (Via EEM-MA600/EEM-MA400)			9 V (via EEM-MA600)		
Degree of protection	IP20			IP20		
Ambient temperature (operation)	-10 °C ... 55 °C (14 °F to 131 °F)			-10 °C ... 55 °C (14 °F to 131 °F)		
EMC note	Class A product, see page 605			Class A product, see page 605		
Conformance/Approvals						
Conformance	CE-compliant			CE-compliant		
UL, USA/Canada	UL 61010-1			UL 61010-1		
	Ordering data			Ordering data		
Description	Type	Order No.	Pcs./Pkt.	Type	Order No.	Pcs./Pkt.
Communication module (for EEM-MA400) RS-485 (JBUS/Modbus/RTU)	EEM-RS485-MA400	2901365	1			
Communication module (for EEM-MA600) RS-485 (JBUS/Modbus/RTU)	EEM-RS485-MA600	2901367	1			
D-SUB (PROFIBUS DP)				EEM-PB 12-MA600	2901418	1

Communication modules

EEM-ETH-MA600

- Ethernet
- Modbus/TCP
- Integrated web server

EEM-ETH-RS485-MA600

- Ethernet gateway to RS-485
- Modbus/TCP / Modbus/RTU
- Integrated web server



Ethernet with integrated web server



Ethernet gateway with integrated web server

	Technical data			Technical data		
Serial port						
Output description	Modbus/TCP Ethernet (RJ45)			Modbus/TCP Ethernet (RJ45)		
Serial transmission speed	10/100 Mbps			10/100 Mbps		
General data						
Supply voltage	9 V (via EEM-MA600)			9 V (via EEM-MA600)		
Degree of protection	IP20			IP20		
Ambient temperature (operation)	-10 °C ... 55 °C (14 °F to 131 °F)			-10 °C ... 55 °C (14 °F to 131 °F)		
EMC note	Class A product, see page 605			Class A product, see page 605		
Conformance/Approvals						
Conformance	CE-compliant			CE-compliant		
UL, USA/Canada	UL 61010-1			UL 61010-1		
	Ordering data			Ordering data		
Description	Type	Order No.	Pcs./Pkt.	Type	Order No.	Pcs./Pkt.
Communication module (for EEM-MA600) Ethernet	EEM-ETH-MA600	2901373	1			
Ethernet gateway				EEM-ETH-RS485-MA600	2901374	1

Monitoring

Energy and power measurement

Function module

Plug-in function module for the EEM-MA400 energy meter.

EEM-IMP-MA400

- One configurable pulse output or one configurable threshold value



Pulse module

Output
Output description
Maximum switching voltage
General data
Supply voltage
Degree of protection
Ambient temperature (operation)
Conformance/Approvals
Conformance
UL, USA/Canada

Technical data	
Relay output	100 V DC
Supply voltage	9 V (via EEM-MA400)
Degree of protection	IP20
Ambient temperature (operation)	-10 °C ... 55 °C (14 °F to 131 °F)
Conformance/Approvals	CE-compliant
Conformance	UL 61010-1

Description
Function module (for EEM-MA400) with one pulse or alarm output

Ordering data		
Type	Order No.	Pcs./Pkt.
EEM-IMP-MA400	2904314	1

Function module

Plug-in function module for the EEM-MA600 energy meter

EEM-IMP-MA600

- Two configurable pulse outputs



Pulse module

Output
Output description
Maximum switching voltage
General data
Supply voltage
Degree of protection
Ambient temperature (operation)
Conformance/Approvals
Conformance
UL, USA/Canada

Technical data	
Relay output	100 V DC
Supply voltage	9 V (via EEM-MA600)
Degree of protection	IP20
Ambient temperature (operation)	-10 °C ... 55 °C (14 °F to 131 °F)
Conformance/Approvals	CE-compliant
Conformance	UL 61010-1

Description
Function module (for EEM-MA600) with two configurable pulse outputs

Ordering data		
Type	Order No.	Pcs./Pkt.
EEM-IMP-MA600	2904313	1

Accessories

DIN rail adapter

- For mounting the EEM-MA600 or EEM-MA400 energy meters on a 35 mm DIN rail according to EN 60715

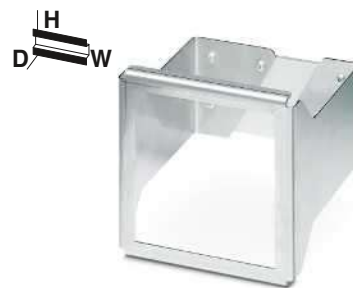

For mounting on DIN rails

ERIC

General data

Vibration resistance
DIN rail clip material
Fixing sheet material
Dimensions W/H/D

Technical data

57 Hz ... 150 Hz (2 g)
Aluminum, natural anodized
Stainless steel VA
116 / 112 / 115 mm

Ordering data**Description**

DIN rail adapter for EEM-MA600 and EEM-MA400

Type

EEM-MKT-DRA

Order No.

2902078

**Pcs./
Pkt.**

1

Monitoring

Energy and power measurement

Controller solution for usage data acquisition



The EMlog software from Phoenix Contact provides an efficient solution for recording energy data relating to heat, cold, air, and electricity when used in conjunction with the ILC 191 ME/AN modular Inline controller. This allows you to keep an eye on your resources and manage the consumption levels of your machines and systems.

Your advantages:

- Easy startup without programming knowledge
- Easy parameterization, thanks to web-based interface
- Direct parameterization of predefined sensors
- Existing configurations can be reused



Solution for usage data acquisition



Interfaces	
INTERBUS local bus (master)	
Ethernet	
Parameterization/operation/diagnostics	
INTERBUS master	
Number of devices with parameter channel	
Number of supported devices	
Amount of process data	
Digital inputs/outputs	
Number of inputs	8
Number of outputs	4
Analog inputs/outputs	
Number of inputs	2
Number of outputs	2
IEC-61131 runtime system	
Programming tool	PC WORX / PC WORX EXPRESS
Processor	Altera Nios II 64 MHz
Program memory	1 Mbyte
Mass storage	1 Mbyte
Retentive mass storage	48 kByte (NVRAM)
Number of data blocks	depends on mass storage
Number of timers, counters	depends on mass storage
Number of control tasks	8
Real-time clock	Yes
Power supply	
Supply voltage	24 V DC
Supply voltage range	19.2 V DC ... 30 V DC
Typical current consumption	310 mA
General data	
Dimensions	W / H / D 164 mm / 136.8 mm / 71.5 mm
Degree of protection	IP20
Ambient temperature (operation)	-25 °C ... 55 °C
EMC note	Class A product, see page 605

Technical data

Inline data jumper	
2 x RJ45 socket	
1 x 6-pos. MINI DIN socket (PS/2)	
max. 24	
max. 128	
max. 4096 Bit (INTERBUS)	
max. 32768 Bit (internal Modbus /TCP client)	
8	
4	
2	
2	
PC WORX / PC WORX EXPRESS	
Altera Nios II 64 MHz	
1 Mbyte	
1 Mbyte	
48 kByte (NVRAM)	
depends on mass storage	
depends on mass storage	
8	
Yes	
24 V DC	
19.2 V DC ... 30 V DC	
310 mA	
W / H / D	164 mm / 136.8 mm / 71.5 mm
IP20	
-25 °C ... 55 °C	
Class A product, see page 605	

Description
Compact controller , complete with accessories (connector and marking field) - Analog inputs/outputs
Program and configuration memory , plug-in, 2 GB with license key and user program for reading from measuring devices
Programming cable
COM CAB MINI DIN

Ordering data

Type	Order No.	Pcs./ Pkt.
ILC 191 ME/AN	2700074	1
SD FLASH 2GB EMLOG	2403484	1

Accessories

COM CAB MINI DIN	2400127	1
------------------	---------	---

Complete packages for data logging

The PSK RTU 50 is a multifunctional RTU (Remote Telemetry Unit), which combines the functions of a data logger, gateway, and alarm manager. The PSK RTU 50 offers various communication options, was developed with low power technology and allows independent operation, e.g., with batteries or solar cells.

Your advantages:

- GSM/GPRS modem
- Ethernet interface
- IEC 60870-5-101
- IEC 60870-5-104
- Modbus/RTU



Multifunctional data logger

		Technical data		
Interfaces		RS-232		
Interfaces		RS-232/-485		
		Serial		
		Ethernet		
Digital inputs/outputs		4		
Number of inputs		2 (Relay output)		
Number of outputs				
Analog inputs		2		
Number of inputs				
IEC-61131 runtime system		832 kByte		
Program memory		1 Mbyte		
Retentive mass storage		Yes (battery-backed)		
Real-time clock				
Power supply		24 V DC		
Supply voltage		5 mA		
Typical current consumption				
General data		475 g		
Weight		210 mm		
Width		110 mm		
Height		45 mm		
Depth		IP20		
Degree of protection		-20 °C ... 65 °C		
Ambient temperature (operation)				
		Ordering data		
Description		Type	Order No.	Pcs./Pkt.
Multifunctional data logger		PSK RTU 50	2400018	1

Compressed air meters

Use meters from Phoenix Contact to monitor the use of compressed air, an expensive production resource. By using compressed air efficiently, you can decrease compressor usage and therefore reduce energy costs. The calorimetric measuring procedure records even the smallest consumption rates. You can therefore detect wear or leaks based on the amount of air consumed.

Use compressed air meters to acquire the following values:

- The current volumetric flow according to ISO 2533 and DIN 1343
- The total volume used
- The temperature of the compressed air in the monitored operating processes

The compressed air meters impress thanks to their:

- Detailed reference measurement with flow rate, total volume, and temperature display
- Intelligent sensor communication, thanks to IO-Link technology
- A measuring range from 0.06 to 700.0 Nm³/h
- Flexible use, thanks to IP65 protection: resistant to dust and splash water

 IO-Link



Compressed air meter up to 75 Nm³/h

Flow monitoring	
Measuring range	
Display area	
Repeatability	
Response time	
Measured value error	
Temperature monitoring	
Measuring range	
Display area	
Response time	
Resolution	
Accuracy	
Supply for module electronics	
Connection method	
No. of pos.	
Supply voltage range	
Current draw	
Digital outputs	
Pulse value	
Pulse length	
Delay time	
Analog outputs	
Type of protection	
Current output signal	
Load/output load current output	
General data	
Weight	
Width	
Height	
Depth	
Degree of protection	
Protection class	
Ambient temperature (operation)	
Ambient temperature (storage/transport)	
Vibration resistance in acc. with EN 60068-2-6/IEC 60068-2-6	

Technical data	
PSK AFS6050IOL	PSK AFS6000IOL
	0.20 Nm ³ /h ... 75 Nm ³ /h
	0.00 Nm ³ /h ... 90 Nm ³ /h
	±1.5% of the measured value
	< 0.1 s ((dAP = 0))
±15 % of the measured value	Depending on the air quality:
+1.5 % of the measuring range final value	±3% of the measured value
	+ 0.3% of the measuring range final value; ±6% of the measured value + 0.6% of the measuring range final value
	0 °C ... 60 °C
	-12 °C ... 72 °C
	30 s (Q > 0.1 Nm ³ /h)
	0.5 °C
	± 2.5 °C (Q > 0.1 Nm ³ /h)
	M12 connector
	4
	19 V DC ... 30 V DC
	< 100 mA
	0.0010 m ³ ... 1000000 m ³
	min. 0.04 s
	0.5 s (Operational readiness)
	Short-circuit protection, polarity reversal protection
	4 mA ... 20 mA
	≤ 500 Ω
	581 g
	961 g
	45 mm
	300 mm
	79.5 mm
	76.8 mm
	IP65
	III
	0 °C ... 60 °C
	-20 °C ... 85 °C
	5g (55 ... 2000 Hz)

Description
Compressed air meter: G1/2 process connection, measuring range up to 75 Nm ³ /h
Compressed air meter: G1/2 process connection, measuring range up to 75 Nm ³ /h
Compressed air meter: R1/4 process connection, measuring range up to 15 Nm ³ /h
Compressed air meter: R1 process connection, measuring range up to 225 Nm ³ /h
Compressed air meter: R2 process connection, measuring range up to 700 Nm ³ /h

Ordering data		
Type	Order No.	Pcs./Pkt.
PSK AFS6050IOL	2700704	1
PSK AFS6000IOL	2700707	1

IO-Link



Compressed air meter up to 15 Nm³/h

IO-Link



Compressed air meter up to 225 Nm³/h

IO-Link



Compressed air meter up to 700 Nm³/h

Technical data

0.04 Nm³/h ... 15 Nm³/h
 0.00 Nm³/h ... 18 Nm³/h
 ±1.5% of the measured value
 < 0.1 s ((dAP = 0))
 Depending on the air quality: ±3% of the measured value + 0.3% of the measuring range final value; ±6% of the measured value + 0.6% of the measuring range final value

0 °C ... 60 °C
 -12 °C ... 72 °C
 30 s (Q > 0.1 Nm³/h)
 0.5 °C
 ± 2.5 °C (Q > 0.1 Nm³/h)

M12 connector
 4
 19 V DC ... 30 V DC
 < 100 mA

0.0010 m³ ... 1000000 m³
 min. 0.2 s
 0.5 s (Operational readiness)

Short-circuit protection, polarity reversal protection
 4 mA ... 20 mA
 ≤ 500 Ω

887 g
 45 mm
 193.3 mm
 74.5 mm
 IP65
 III
 0 °C ... 60 °C
 -20 °C ... 85 °C
 5g (55 ... 2000 Hz)

Technical data

0.70 Nm³/h ... 225 Nm³/h
 0.00 Nm³/h ... 270 Nm³/h
 ±1.5% of the measured value
 < 0.1 s ((dAP = 0))
 Depending on the air quality: ±3% of the measured value + 0.3% of the measuring range final value; ±6% of the measured value + 0.6% of the measuring range final value

0 °C ... 60 °C
 -12 °C ... 72 °C
 30 s (Q > 0.1 Nm³/h)
 0.5 °C
 ± 2.5 °C (Q > 0.1 Nm³/h)

M12 connector
 4
 19 V DC ... 30 V DC
 < 100 mA

0.0030 m³ ... 3000000 m³
 min. 0.02 s
 1 s (Operational readiness)

Short-circuit protection, polarity reversal protection
 4 mA ... 20 mA
 ≤ 500 Ω

2.053 kg
 45 mm
 475 mm
 88.5 mm
 IP65
 III
 0 °C ... 60 °C
 -20 °C ... 85 °C
 5g (55 ... 2000 Hz)

Technical data

2.30 Nm³/h ... 700 Nm³/h
 0.00 Nm³/h ... 840 Nm³/h
 ±1.5% of the measured value
 < 0.1 s ((dAP = 0))
 Depending on the air quality: ± 3% of the measured value + 0.3% of the measuring range final value; ± 6% of the measured value + 0.6% of the measuring range final value

0 °C ... 60 °C
 -12 °C ... 72 °C
 30 s (Q > 0.1 Nm³/h)
 0.5 °C
 ± 2.5 °C (Q > 0.1 Nm³/h)

M12 connector
 4
 19 V DC ... 30 V DC
 < 100 mA

0.0100 m³ ... 4000000 m³
 min. 0.043 s
 0.5 s (Operational readiness)

Short-circuit protection, polarity reversal protection
 4 mA ... 20 mA
 ≤ 500 Ω

4.332 kg
 133 mm
 475 mm
 -
 IP65
 III
 0 °C ... 60 °C
 -20 °C ... 85 °C
 5g (55 ... 2000 Hz)

Ordering data

Type	Order No.	Pcs./Pkt.
PSK AFS5000IOL	2700705	1

Ordering data

Type	Order No.	Pcs./Pkt.
PSK AFS8000IOL	2700708	1

Ordering data

Type	Order No.	Pcs./Pkt.
PSK AFS2000IOL	2700709	1

Pressure sensor

Pressure sensor with IO-Link

Pressure sensors from Phoenix Contact detect the operating pressure of gas media in a range from -1 to 10 bar. The overload-proof ceramic measuring cell is designed for in excess of 100 million cycles and enables a high switching point accuracy. The pressure switch offers the option of using the set switching points via two switching outputs or reading all process data via the IO-Link interface.

Your advantages:

- IO-Link communication
- Parameterization, diagnostics, and process value monitoring via IO-Link
- Programmable function
- 4-character alphanumeric display

 IO-Link



Pressure sensor up to 10 bar

Pressure monitoring	
Measuring range	-1 bar ... 10 bar (Minimum burst pressure 150 bar)
Pressure resistance	75 bar
Process connection	G1/4 I
Supply for module electronics	
Connection method	M12 connector
No. of pos.	4
Supply voltage range	18 V DC ... 36 V DC
Current draw	< 35 mA
Digital outputs	
Number of outputs	2 (OUT1 = switching output, OUT2 = switching output or diagnostic output)
Connection method	M12 connectors, assigned four times
Delay time	0.3 s (Operational readiness)
IO-Link	
Specification	V1.1
Transmission speed	38.4 kbaud
General data	
Weight	263 g
Width	34 mm
Height	91.5 mm
Depth	48 mm
Degree of protection	IP65
Protection class	III
Ambient temperature (operation)	-25 °C ... 80 °C
Ambient temperature (storage/transport)	-40 °C ... 100 °C
Vibration resistance in acc. with EN 60068-2-6/IEC 60068-2-6	20g (10 Hz ... 2000 Hz)

Technical data

Measuring range	-1 bar ... 10 bar (Minimum burst pressure 150 bar)	
Pressure resistance	75 bar	
Process connection	G1/4 I	
Supply for module electronics		
Connection method	M12 connector	
No. of pos.	4	
Supply voltage range	18 V DC ... 36 V DC	
Current draw	< 35 mA	
Digital outputs		
Number of outputs	2 (OUT1 = switching output, OUT2 = switching output or diagnostic output)	
Connection method	M12 connectors, assigned four times	
Delay time	0.3 s (Operational readiness)	
IO-Link		
Specification	V1.1	
Transmission speed	38.4 kbaud	
General data		
Weight	263 g	
Width	34 mm	
Height	91.5 mm	
Depth	48 mm	
Degree of protection	IP65	
Protection class	III	
Ambient temperature (operation)	-25 °C ... 80 °C	
Ambient temperature (storage/transport)	-40 °C ... 100 °C	
Vibration resistance in acc. with EN 60068-2-6/IEC 60068-2-6	20g (10 Hz ... 2000 Hz)	

Description	
Pressure sensor with indicator.	
G1/4 I process connection, IO-Link communication	

Ordering data

Type	Order No.	Pcs./ Pkt.
PSK APS7004IOL	2700710	1



Extremely versatile

PACT current transformers offer a complete product range for converting alternating currents up to 4000 A into secondary currents of 1 A and 5 A. Depending on requirements, busbar, plug-in, and winding current transformers are available. PACT current transformers are available in different transformation ratios, accuracy classes, and rated powers - in 3000 versions, for your current measurement requirements.

Also available for higher accuracy classes

For standard applications, such as in machine building or systems manufacturing, Phoenix Contact offers current transformers with accuracy classes 0.5 and 1 in a version that cannot be calibrated.

For higher accuracy or for billing purposes in energy supply, type-tested transformers that can be calibrated as well as calibrated transformers are available - with classes 0.2/0.2S/0.5 and 0.5S.



Fast and secure installation

The current transformer quick-action mechanism offers the following advantages:

- Tool-free mounting
- Considerable reduction in installation time
- Easy handling and secure fastening by pressing with finger
- Current transformers align themselves – no need for subsequent alignment



Variable and space-saving mounting

In addition to the vertical and horizontal mounting position, the optional accessories offer further installation options such as mounting on the DIN rail or on the control cabinet panel.

All PACT current transformers are just 30 mm wide. This saves space – for example with flat mounting when measuring branch outlets.

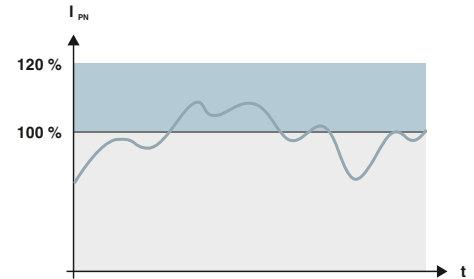

Safely detecting current peaks

PACT current transformers can be used to safely detect current peaks greater than the rated nominal current strength – without resulting in any damage. The transformers are designed for a thermal nominal continuous current of 120% of the primary rated current strength.

Example: a PACT transformer with a specified rated power of 10 VA actually delivers 14.4 VA on a continual basis.

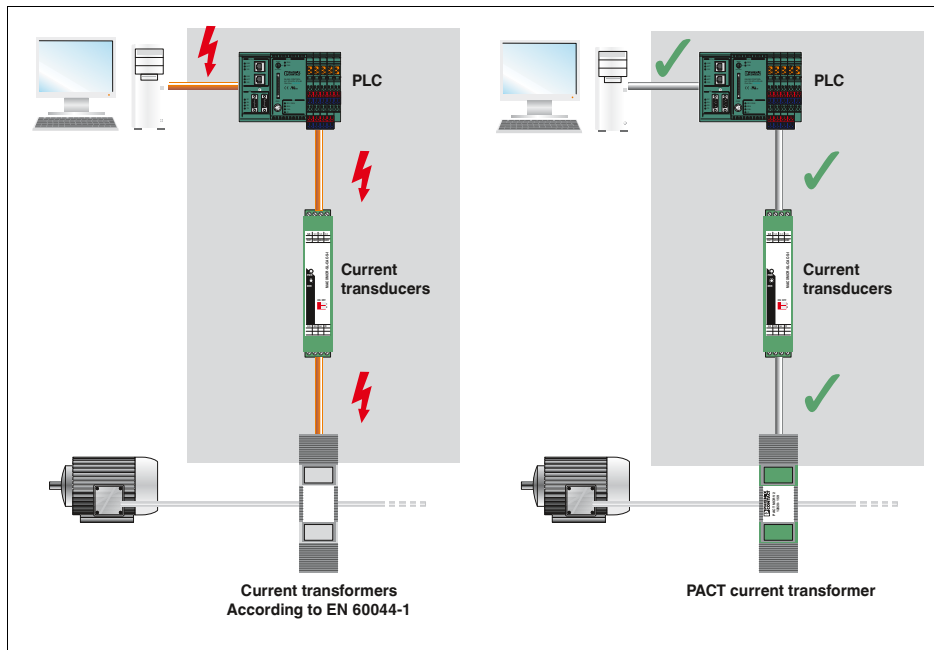

Safe isolation

PACT current transformers are manufactured according to EN 50178. This is relevant for electronic equipment for use in power installations.

EN 50178 differs considerably from EN 60044, the usual standard for transformers, with regard to safety.

Your advantages:

- PACT current transformers offer safe isolation, thanks to greater air clearances and creepage distances.
- PACT current transformers ensure that there is no sparkover on the secondary side of the transformer and human life is protected inside and outside the control cabinet.
- Up to 1000 V (L-N) operating voltage possible
- Routine testing with 12 kV (1.2/50 μ s)
- Meets overvoltage category 3

Monitoring

Current measurement

Current transformer selection guide

- Complete range consisting of winding, busbar, and window-type current transformers
- Popular types available from stock; alternatively, order key can be used for custom dimensioning
- Versions available to support official calibration



Selection

- Select your transformer in accordance with the dimensions of the copper rail
- Specify the four electrical characteristics of the transformer:

- 1. The primary rated current strength I_{pn}** - the maximum amperage occurring in the path to be measured
- 2. The secondary rated current I_{sn}** - supplied to the downstream measuring devices
- 3. Class** - accuracy for adherence to the specified tolerances
- 4. Rated power S_n [VA]** - takes account of all the loads occurring in the measuring circuit

Input data

Thermal rated short-time current
Rated surge current
Rated frequency

Surge current limitation factor

General data

Rated insulation voltage
Impulse withstand voltage
Insulating material class
Connection capacity of secondary terminals
Ambient temperature (operation)
Standards/regulations
Housing material

Technical data

$I_{th} = 60 \cdot I_n$
 $I_{dyn} = 2.5 \cdot I_{th}$
50 Hz ... 60 Hz
50 Hz
FS 5

1 kV (Phase/neutral conductor)
12 kV (1.2/50 μ s)
E
2 x (2.5 x 4) mm
-25 °C ... 40 °C
EN 50178 , EN 61869
WELLAMID 6600-PA66-GV 20 HWV0CP

Calculation guide

Determination of the secondary side rated power S_n

All the occurring loads must be added:

- Calculate the power requirement of the copper wire (forward and return line)
- Take into account the power requirement of the connected devices (measuring devices)
- Add a reserve requirement

$$S_n \text{ total} = S_n \text{ copper wire} + S_n \text{ measuring device} + S_n \text{ reserve}$$

Power requirement of copper wires with a different diameter

Conductor cross section in mm ²	Rated power in VA/m (consider the forward and return line)	
	Secondary current I_{sn} 5 A	Secondary current I_{sn} 1 A
1.5	0.2917	0.0117
2.5	0.1750	0.0070
4	0.1094	0.0044
6	0.0729	0.0029

Example:

S_n copper wire = cable length x 2 x rated power
 S_n copper wire = 10 m x 2 x 0.1750 VA/m = 3.50 VA

S_n measuring device = 2 VA

S_n reserve < 0.5 x (S_n copper wire + S_n measuring device)

S_n reserve = 2 VA

S_n total = S_n copper wire + S_n measuring device + S_n reserve
 S_n total = 3.5 VA + 2 VA + 2 VA = 7.5 VA

Order key - example for PACT MCR-V2-3015-60

Preferred types that can be ordered directly are marked in green in the selection table.

Order No.	Primary current I_{pn}	Secondary current I_{sn}	Class	Rated power S_n
2277271	IP02000	IS05	C10	P750
	IP00600 $\hat{=}$ 60 A IP00750 $\hat{=}$ 75 A IP00800 $\hat{=}$ 80 A IP01000 $\hat{=}$ 100 A IP01250 $\hat{=}$ 125 A IP02000 $\hat{=}$ 200 A IP02500 $\hat{=}$ 250 A	IS01 $\hat{=}$ 1 A IS05 $\hat{=}$ 5 A	C02 $\hat{=}$ 0.2 C05 $\hat{=}$ 0.5 C10 $\hat{=}$ 1	P125 $\hat{=}$ 1.25 VA P250 $\hat{=}$ 2.5 VA P375 $\hat{=}$ 3.75 VA P500 $\hat{=}$ 5.0 VA P750 $\hat{=}$ 7.5 VA P1000 $\hat{=}$ 10 VA

Selection table (extract)

I_{sn}	Cl.	Primary rated current strength I_{pn} [A]								Rated power S_n [VA]
		60	75	80	100	125	150	200	250	
1 A	0.5							2.5	2.5	7.5
	1	1.25	2.5	2.5	2.5	2.5	2.5	2.5	2.5	
5 A	0.5							2.5	2.5	10
	1	1.25	1.25	1.25	2.5	2.5	2.5	2.5	2.5	

Current transformers

PACT MCR-V1-21-44

- Primary rated current I_{pn} : 0...(50...500) A
- Circular conductor dimensions: \varnothing 21 mm

Notes:
 Our configurator, which is available at phoenixcontact.net/products, makes ordering easy.
 The relevant installation accessories can be found on page 233

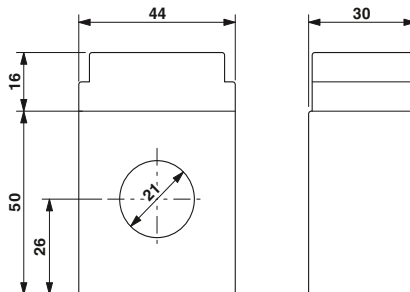

Busbar curr. transf., official calibration as an option

ERIC

Ordering data

Description	Rated power S_n	Type	Order No.	Pcs./Pkt.
Primary rated current I_{pn}:				
- 50 A	1.25 VA	PACT MCR-V1-21-44- 50-5A-1	2277019	1
- 75 A	2.5 VA	PACT MCR-V1-21-44- 75-5A-1	2277611	1
- 100 A	2.5 VA	PACT MCR-V1-21-44-100-5A-1	2277022	1
- 125 A	3.75 VA	PACT MCR-V1-21-44-125-5A-1	2277763	1
- 150 A	5 VA	PACT MCR-V1-21-44-150-5A-1	2277035	1
- 200 A	5 VA	PACT MCR-V1-21-44-200-5A-1	2277776	1
- 250 A	5 VA	PACT MCR-V1-21-44-250-5A-1	2277048	1
- 300 A	10 VA	PACT MCR-V1-21-44-300-5A-1	2277789	1
- 400 A	5 VA	PACT MCR-V1-21-44-400-5A-1	2277051	1
- 500 A	10 VA	PACT MCR-V1-21-44-500-5A-1	2277792	1
Current transformers , to determine the desired current transformer type, refer to the order key below				
Current transformers that support official calibration: To specify the type of current transformer you require, please refer to the order key (see notes)				
		PACT MCR-V1-21-44	2277268	1
		PACT MCR-V1C-21-44	2277420	1

Add order key from the selection table (ordering example marked in orange)

Order No.	Primary current I_{pn}	Secondary current I_{sn}	Class	Rated power S_n
2277268	IP05000	IS01	C05	P1000

Selection table PACT MCR-V1-21-44 (Order No.: 2277268)

I_{sn}	Cl.	Primary rated current strength I_{pn} [A]												Rated power S_n [VA]			
		50	60	75	80	100	125	150	200	250	300	400	500				
IS01 $\cong 1$ A	C05 $\cong 0.5$					1.25	2.5	2.5	2.5	2.5	2.5	2.5	2.5	2.5	2.5	2.5	2.5
	C10 $\cong 1$							3.75	5	5	5	5	5	5	5	5	5
IS05 $\cong 5$ A	C05 $\cong 0.5$					1.25	1.25	1.25	2.5	2.5	2.5	2.5	2.5	2.5	2.5	2.5	2.5
	C10 $\cong 1$	1.25	1.25	2.5	2.5	2.5	2.5	2.5	2.5	2.5	2.5	2.5	2.5	2.5	2.5	2.5	2.5

Monitoring

Current measurement

Current transformers

PACT MCR-V2-3015-60

- Primary rated current I_{pn} :
0...(50...750) A
- Circular conductor dimensions: \varnothing 28 mm
- Rail dimensions:
30x15 mm, 20x20 mm

Notes:
Our configurator, which is available at phoenixcontact.net/products, makes ordering easy.
The relevant installation accessories can be found on page 233

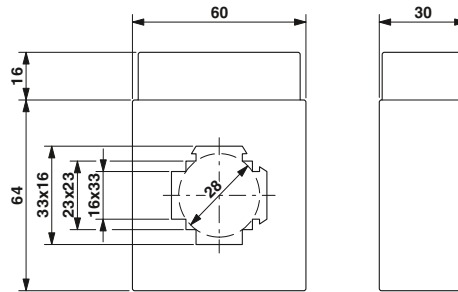

Window-type curr. transformer,
official calibration as an option

ERC

Ordering data

Description	Rated power S_n	Type	Order No.	Pcs./Pkt.
Primary rated current I_{pn}:				
- 60 A	1.25 VA	PACT MCR-V2-3015- 60- 60-5A-1	2277815	1
- 75 A	1.25 VA	PACT MCR-V2-3015- 60- 75-5A-1	2277828	1
- 75 A	1.5 VA	PACT MCR-V2- 3015- 60- 75-5A-1	2276502	1
- 80 A	1.25 VA	PACT MCR-V2-3015- 60- 80-5A-1	2277831	1
- 100 A	2.5 VA	PACT MCR-V2-3015- 60- 100-5A-1	2277064	1
- 125 A	3.75 VA	PACT MCR-V2-3015- 60- 125-5A-1	2277624	1
- 150 A	3.75 VA	PACT MCR-V2-3015- 60- 150-5A-1	2277844	1
- 150 A	5 VA	PACT MCR-V2- 3015- 60-150-5A-1	2277077	1
- 200 A	5 VA	PACT MCR-V2-3015- 60- 200-5A-1	2277637	1
- 200 A	7.5 VA	PACT MCR-V2-3015- 60- 200-5A-1	2277857	1
- 250 A	5 VA	PACT MCR-V2- 3015- 60-250-5A-1	2276544	1
- 250 A	7.5 VA	PACT MCR-V2-3015- 60- 250-5A-1	2277860	1
- 250 A	10 VA	PACT MCR-V2- 3015- 60-250-5A-1	2277080	1
- 300 A	7.5 VA	PACT MCR-V2-3015- 60- 300-5A-1	2277640	1
- 400 A	10 VA	PACT MCR-V2- 3015- 60-400-5A-1	2277093	1
- 500 A	10 VA	PACT MCR-V2-3015- 60- 500-5A-1	2277653	1
- 600 A	10 VA	PACT MCR-V2-3015- 60- 600-5A-1	2277103	1
- 750 A	10 VA	PACT MCR-V2-3015- 60- 750-5A-1	2277666	1
Current transformers, to determine the desired current transformer type, refer to the order key below				
Current transformers that support official calibration: To specify the type of current transformer you require, please refer to the order key (see notes)				
PACT MCR-V2- 3015- 60			2277271	1
PACT MCR-V2C- 3015- 60			2277433	1
Accessories				
Quick-action mechanism				
Fixing pin length 40 mm		PACT-FAST-MNT-W16-L40	2276638	1
Fixing pin length 65 mm		PACT-FAST-MNT-W16-L65	2276641	1

Add **order key** from the selection table (ordering example marked in orange)

Order No.	Primary current I_{pn}	Secondary current I_{sn}	Class	Rated power S_n
2277271	IP07500	IS01	C05	P1500

Selection table PACT MCR-V2-3015-60 (Order No.: 2277271)

I_{sn}	Cl.	Primary rated current strength I_{pn} [A]													Rated power S_n [VA]				
		50	60	75	80	100	125	150	200	250	300	400	500	600		750			
IS01 \cong 1 A	C05 \cong 0.5					1.25	2.5	2.5		2.5	2.5	2.5	2.5	2.5	2.5	2.5	2.5	2.5	2.5
										3.75	5	5	5	5	5	5	5	5	5
	C10 \cong 1																		
IS05 \cong 5 A	C05 \cong 0.5																		
	C10 \cong 1																		

Current transformers

PACT MCR-V2-4012-70

- Primary rated current I_{pn} : 0...(75...1000) A
- Circular conductor dimensions: \varnothing 33 mm
- Rail dimensions: 40x12 mm, 2x 30x10 mm

Notes:
 Our configurator, which is available at phoenixcontact.net/products, makes ordering easy.
 The relevant installation accessories can be found on page 233

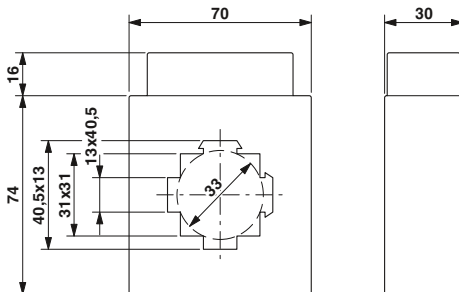

Window-type curr. transformer, official calibration as an option

ERIC

Ordering data

Description	Rated power S_n	Type	Order No.	Pcs./Pkt.
Primary rated current I_{pn}:				
- 250 A	5 VA	PACT MCR-V2-4012- 70- 250-5A-1	2277116	1
- 300 A	7.5 VA	PACT MCR-V2-4012- 70- 300-5A-1	2277679	1
- 400 A	7.5 VA	PACT MCR-V2-4012- 70- 400-5A-1	2277129	1
- 500 A	10 VA	PACT MCR-V2-4012- 70- 500-5A-1	2277682	1
- 600 A	10 VA	PACT MCR-V2-4012- 70- 600-5A-1	2277132	1
- 750 A	10 VA	PACT MCR-V2-4012- 70- 750-5A-1	2277695	1
- 800 A	10 VA	PACT MCR-V2-4012- 70- 800-5A-1	2277145	1
- 1000 A	10 VA	PACT MCR-V2-4012- 70-1000-5A-1	2277158	1
Current transformers, to determine the desired current transformer type, refer to the order key below				
Current transformers that support official calibration: To specify the type of current transformer you require, please refer to the order key (see notes)				
PACT MCR-V2- 4012- 70			2277284	1
PACT MCR-V2C- 4012- 70			2277446	1
Accessories				
PACT-FAST-MNT-W13-L40			2276612	1
PACT-FAST-MNT-W13-L65			2276625	1

Quick-action mechanism
 Fixing pin length 40 mm
 Fixing pin length 65 mm

Add order key from the selection table (ordering example marked in orange)

Order No.	Primary current I_{pn}	Secondary current I_{sn}	Class	Rated power S_n
2277284	IP010000	IS05	C10	P250

Selection table PACT MCR-V2-4012-70 (Order No.: 2277284)

I_{sn}	Cl.	Primary rated current strength I_{pn} [A]												Rated power S_n [VA]				
		75	80	100	125	150	200	250	300	400	500	600	750		800	1000		
IS01 \cong 1 A	C05 \cong 0.5				1.25	2.5	2.5	2.5	2.5	2.5	2.5	2.5	2.5	2.5	2.5	2.5	2.5	15 15 15 15
							3.75	5	5	5	5	5	5	5	5	5	5	
	C10 \cong 1		1.25	1.25	2.5	2.5	2.5	2.5	2.5	2.5	2.5	2.5	2.5	2.5	2.5	2.5	2.5	
						3.75	5	5	5	5	5	5	5	5	5	5	5	
IS05 \cong 5 A	C05 \cong 0.5				1.25	2.5	2.5	2.5	2.5	2.5	2.5	2.5	2.5	2.5	2.5	2.5	2.5	15 15 15 15
							3.75	5	5	5	5	5	5	5	5	5	5	
	C10 \cong 1		1.25	1.25	2.5	2.5	2.5	2.5	2.5	2.5	2.5	2.5	2.5	2.5	2.5	2.5	2.5	
						3.75	5	5	5	5	5	5	5	5	5	5	5	

Monitoring

Current measurement

Current transformers

PACT MCR-V2-5012-85

- Primary rated current I_{pn} : 0...(100...1500) A
- Circular conductor dimensions: \varnothing 42 mm
- Rail dimensions: 50x12 mm, 2x 40x10 mm

Notes:
 Our configurator, which is available at phoenixcontact.net/products, makes ordering easy.
 The relevant installation accessories can be found on page 233

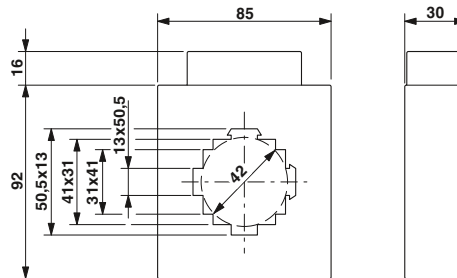

Window-type curr. transformer, official calibration as an option

ERC

Ordering data

Description	Rated power S_n	Type	Order No.	Pcs./Pkt.
Primary rated current I_{pn}:				
- 150 A	3.75 VA	PACT MCR-V2-5012- 85- 150-5A-1	2276117	1
- 200 A	5 VA	PACT MCR-V2-5012- 85- 200-5A-1	2276120	1
- 250 A	7.5 VA	PACT MCR-V2-5012- 85- 250-5A-1	2276133	1
- 300 A	10 VA	PACT MCR-V2-5012- 85- 300-5A-1	2276146	1
- 400 A	10 VA	PACT MCR-V2-5012- 85- 400-5A-1	2277161	1
- 500 A	15 VA	PACT MCR-V2-5012- 85- 500-5A-1	2276159	1
- 600 A	10 VA	PACT MCR-V2-5012- 85- 600-5A-1	2277174	1
- 600 A	15 VA	PACT MCR-V2-5012- 85- 600-5A-1	2276162	1
- 750 A	10 VA	PACT MCR-V2-5012- 85- 750-5A-1	2276175	1
- 800 A	10 VA	PACT MCR-V2-5012- 85- 800-5A-1	2277187	1
- 1000 A	10 VA	PACT MCR-V2-5012- 85-1000-5A-1	2276463	1
- 1000 A	15 VA	PACT MCR-V2-5012- 85-1000-5A-1	2277190	1
- 1250 A	15 VA	PACT MCR-V2-5012- 85-1250-5A-1	2277200	1
- 1500 A	15 VA	PACT MCR-V2-5012- 85-1500-5A-1	2276188	1
Current transformers , to determine the desired current transformer type, refer to the order key below				
Current transformers that support official calibration: To specify the type of current transformer you require, please refer to the order key (see notes)				
		PACT MCR-V2- 5012- 85	2277297	1
		PACT MCR-V2C- 5012- 85	2277459	1

Accessories

Quick-action mechanism	Order No.	Pcs./Pkt.
Fixing pin length 40 mm	PACT-FAST-MNT-W13-L40	2276612
Fixing pin length 65 mm	PACT-FAST-MNT-W13-L65	2276625

Add **order key** from the selection table (ordering example marked in orange)

Order No.	Primary current I_{pn}	Secondary current I_{sn}	Class	Rated power S_n
2277297	IP02500	IS01	C10	P750

Selection table PACT MCR-V2-5012-85 (Order No.: 2277297)

I_{sn}	Cl.	Primary rated current strength I_{pn} [A]													Rated power S_n [VA]				
		100	125	150	200	250	300	400	500	600	750	800	1000	1250		1500			
$\cong 1$ A	C05 $\cong 0.5$			1.25	2.5	2.5	2.5	2.5	2.5	2.5	2.5	2.5	2.5	2.5	2.5	2.5	2.5	2.5	
					5	5	5	5	5	5	5	5	5	5	5	5	5	5	
	C10 $\cong 1$																		
$\cong 5$ A	C05 $\cong 0.5$			1.25	2.5	2.5	2.5	2.5	2.5	2.5	2.5	2.5	2.5	2.5	2.5	2.5	2.5	2.5	
					5	5	5	5	5	5	5	5	5	5	5	5	5	5	
	C10 $\cong 1$																		

Current transformers

PACT MCR-V2-6015-85

- Primary rated current I_{pn} : 0...(200...1600) A
- Circular conductor dimensions: \varnothing 52 mm
- Rail dimensions: 60x15 mm, 2x 50x10 mm, 40x40 mm

Notes:
 Our configurator, which is available at phoenixcontact.net/products, makes ordering easy.
 The relevant installation accessories can be found on page 233

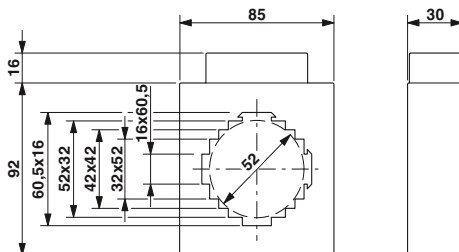

Window-type curr. transformer, official calibration as an option

ERIC

Ordering data

Description	Rated power S_n	Type	Order No.	Pcs./Pkt.
Primary rated current I_{pn}:				
- 200 A	2.5 VA	PACT MCR-V2-6015- 85- 200-5A-1	2277873	1
- 250 A	2.5 VA	PACT MCR-V2-6015- 85- 250-5A-1	2277886	1
- 300 A	2.5 VA	PACT MCR-V2-6015- 85- 300-5A-1	2277899	1
- 400 A	2.5 VA	PACT MCR-V2-6015- 85- 400-5A-1	2277909	1
- 500 A	5 VA	PACT MCR-V2-6015- 85- 500-5A-1	2277912	1
- 600 A	10 VA	PACT MCR-V2-6015- 85- 600-5A-1	2277925	1
- 750 A	10 VA	PACT MCR-V2-6015- 85- 750-5A-1	2277938	1
- 800 A	10 VA	PACT MCR-V2-6015- 85- 800-5A-1	2277941	1
- 1000 A	15 VA	PACT MCR-V2-6015- 85-1000-5A-1	2277954	1
- 1250 A	15 VA	PACT MCR-V2-6015- 85-1250-5A-1	2277967	1
- 1600 A	15 VA	PACT MCR-V2-6015- 85-1600-5A-1	2277983	1
Current transformers, to determine the desired current transformer type, refer to the order key below				
Current transformers that support official calibration: To specify the type of current transformer you require, please refer to the order key (see notes)				
PACT MCR-V2- 6015- 85			2277336	1
PACT MCR-V2C- 6015- 85			2277462	1
Accessories				
PACT-FAST-MNT-W16-L40			2276638	1
PACT-FAST-MNT-W16-L65			2276641	1

Add order key from the selection table (ordering example marked in orange)

Order No.	Primary current I_{pn}	Secondary current I_{sn}	Class	Rated power S_n
2277336	IP05000	IS01	C10	P375

Selection table PACT MCR-V2-6015-85 (Order No.: 2277336)

I_{sn}	Cl.	Primary rated current strength I_{pn} [A]											Rated power S_n [VA]	
		200	250	300	400	500	600	750	800	1000	1250	1500		1600
IS01 \cong 1 A	C05 \cong 0.5		1.25	1.25	1.25	2.5	2.5	2.5	2.5	2.5	5	5	5	5
	C10 \cong 1	2.5	2.5	2.5	2.5	3.75	2.5	2.5	2.5	2.5	5	3.75	3.75	5
IS05 \cong 5 A	C05 \cong 0.5		1.25	1.25	1.25	2.5	2.5	2.5	2.5	2.5	5	5	5	5
	C10 \cong 1	2.5	2.5	2.5	2.5	5	5	5	5	5	10	10	10	10

Monitoring

Current measurement

Current transformers

PACT MCR-V2-6315-95

- Primary rated current I_{pn} : 0...(200...2500) A
- Circular conductor dimensions: \varnothing 53 mm
- Rail dimensions:
63x15 mm
2x 50x10 mm
40x40 mm



Window-type curr. transformer, official calibration as an option

PACT MCR-V2-6040-96

- Primary rated current I_{pn} : 0...(200...2000) A
- Circular conductor dimensions: \varnothing 61 mm
- Rail dimensions:
60x40 mm, 50x50 mm



Window-type curr. transformer, official calibration as an option

Notes:
Our configurator, which is available at phoenixcontact.net/products, makes ordering easy.
The relevant installation accessories can be found on page 233

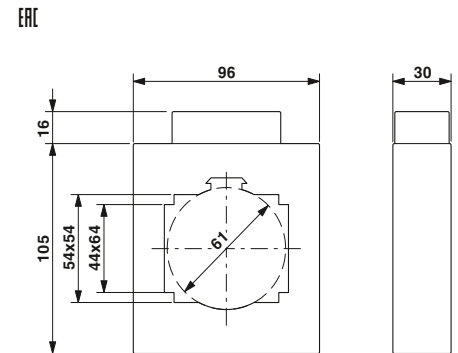
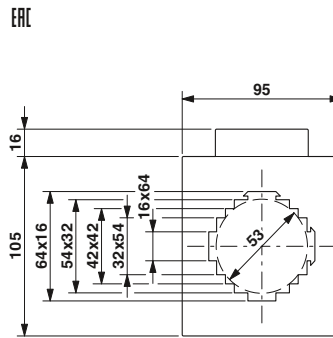

Description	Rated power S_n
Primary rated current I_{pn}:	
- 600 A	10 VA
- 750 A	10 VA
- 800 A	10 VA
- 1000 A	10 VA
- 1250 A	10 VA
- 1250 A	15 VA
- 1500 A	10 VA
- 1600 A	10 VA
- 1600 A	15 VA
- 2000 A	15 VA
Current transformers , to determine the desired current transformer type, refer to the order key below	
Current transformers that support official calibration: To specify the type of current transformer you require, please refer to the order key (see notes)	

Ordering data		
Type	Order No.	Pcs./ Pkt.
PACT MCR-V2-6315- 95- 800-5A-1	2277213	1
PACT MCR-V2-6315- 95-1000-5A-1	2277226	1
PACT MCR-V2-6315- 95-1250-5A-1	2277239	1
PACT MCR-V2-6315- 95-1500-5A-1	2277242	1
PACT MCR-V2-6315- 95-1600-5A-1	2277255	1
PACT MCR-V2- 6315- 95	2277307	1
PACT MCR-V2C- 6315- 95	2277475	1

Ordering data		
Type	Order No.	Pcs./ Pkt.
PACT MCR-V2-6040- 96- 600-5A-1	2276191	1
PACT MCR-V2-6040- 96- 750-5A-1	2276201	1
PACT MCR-V2-6040- 96- 800-5A-1	2276214	1
PACT MCR-V2-6040- 96-1000-5A-1	2277705	1
PACT MCR-V2-6040- 96-1250-5A-1	2276227	1
PACT MCR-V2-6040- 96-1500-5A-1	2277718	1
PACT MCR-V2-6040- 96-1600-5A-1	2276230	1
PACT MCR-V2-6040- 96-2000-5A-1	2276243	1
PACT MCR-V2- 6040- 96	2277349	1
PACT MCR-V2C- 6040- 96	2277488	1

Quick-action mechanism	
Fixing pin length 40 mm	
Fixing pin length 65 mm	

Accessories		
Type	Order No.	Pcs./ Pkt.
PACT-FAST-MNT-W16-L40	2276638	1
PACT-FAST-MNT-W16-L65	2276641	1

Accessories		
Type	Order No.	Pcs./ Pkt.
PACT-FAST-MNT-W16-L40	2276638	1
PACT-FAST-MNT-W16-L65	2276641	1

Add order key from the selection table (ordering example marked in orange)

Order No.	Primary current I_{pn}	Secondary current I_{sn}	Class	Rated power S_n
2277307	IP25000	IS05	C05	P500

Selection table PACT MCR-V2-6315-95 (Order No.: 2277307)

I_{sn}	Cl.	Primary rated current strength I_{pn} [A]													Rated power S_n [VA]	
		200	250	300	400	500	600	750	800	1000	1250	1500	1600	2000		2500
IS01 \cong 1 A	C05 \cong 0.5	2.5	2.5	2.5	2.5	2.5	2.5	5	5	5	5	5	5	5	5	5
	C10 \cong 1	3.75	5	5	5	5	5	10	10	10	10	10	10	10	15	15
	C05 \cong 0.5	2.5	2.5	2.5	2.5	2.5	2.5	5	5	5	5	5	5	5	5	5
IS05 \cong 5 A	C05 \cong 0.5	3.75	5	5	5	5	5	10	10	10	10	10	10	10	10	10
	C10 \cong 1	7.5	10	10	10	10	10	15	15	15	15	15	15	15	15	15
	C10 \cong 1	15	20	20	20	20	20	30	30	30	30	30	30	30	30	30

Selection table PACT MCR-V2-6040-96 (Order No.: 2277349)

I_{sn}	Cl.	Primary rated current strength I_{pn} [A]													Rated power S_n [VA]	
		200	250	300	400	500	600	750	800	1000	1250	1500	1600	2000		
IS01 \cong 1 A	C05 \cong 0.5	2.5	2.5	2.5	2.5	2.5	2.5	5	5	5	5	5	5	5	5	5
	C10 \cong 1	3.75	5	5	5	5	5	10	10	10	10	10	10	10	15	15
	C05 \cong 0.5	2.5	2.5	2.5	2.5	2.5	2.5	5	5	5	5	5	5	5	5	5
IS05 \cong 5 A	C05 \cong 0.5	3.75	5	5	5	5	5	10	10	10	10	10	10	10	10	10
	C10 \cong 1	7.5	10	10	10	10	10	15	15	15	15	15	15	15	15	15
	C10 \cong 1	15	20	20	20	20	20	30	30	30	30	30	30	30	30	30

Current transformers

PACT MCR-V2-8015-105

- Primary rated current I_{pn} : 0...(400...2500) A
- Circular conductor dimensions: \varnothing 61 mm
- Rail dimensions: 80x15 mm, 2x 60x10 mm, 3x 50x10 mm

PACT MCR-V2-8020-105

- Primary rated current I_{pn} : 0...(500...2000) A
- Circular conductor dimensions: \varnothing 70 mm
- Rail dimensions: 2x 80x10 mm, 60x60 mm



Window-type curr. transformer, official calibration as an option



Window-type curr. transformer, official calibration as an option

Notes:
 Our configurator, which is available at phoenixcontact.net/products, makes ordering easy.
 The relevant installation accessories can be found on page 233

ERC

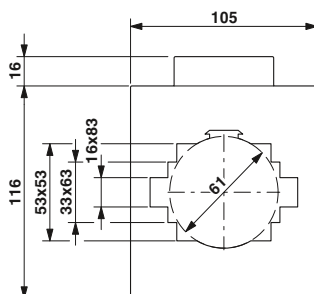

ERC

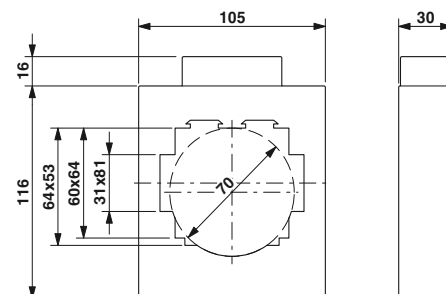

Ordering data

Ordering data

Description	Rated power S_n
Primary rated current I_{pn}:	
- 400 A	7.5 VA
- 500 A	10 VA
- 600 A	10 VA
- 750 A	10 VA
- 800 A	15 VA
- 1000 A	10 VA
- 1000 A	15 VA
- 1250 A	10 VA
- 1500 A	15 VA
- 1600 A	15 VA
- 2000 A	10 VA
- 2000 A	20 VA
- 2500 A	20 VA
Current transformers , to determine the desired current transformer type, refer to the order key below	
Current transformers that support official calibration: To specify the type of current transformer you require, please refer to the order key (see notes)	

Type	Order No.	Pcs./ Pkt.
PACT MCR-V2-8015-105- 400-5A-1	2276256	1
PACT MCR-V2-8015-105- 500-5A-1	2276269	1
PACT MCR-V2-8015-105- 600-5A-1	2276272	1
PACT MCR-V2-8015-105- 750-5A-1	2276285	1
PACT MCR-V2-8015-105- 800-5A-1	2276298	1
PACT MCR-V2-8015-105-1000-5A-1	2277721	1
PACT MCR-V2-8015-105-1000-5A-1	2276308	1
PACT MCR-V2-8015-105-1250-5A-1	2276311	1
PACT MCR-V2-8015-105-1500-5A-1	2277734	1
PACT MCR-V2-8015-105-1600-5A-1	2276324	1
PACT MCR-V2-8015-105-2000-5A-1	2276337	1
PACT MCR-V2-8015-105-2500-5A-1	2276340	1
PACT MCR-V2- 8015-105	2277352	1
PACT MCR-V2C- 8015-105	2277491	1

Type	Order No.	Pcs./ Pkt.
PACT MCR-V2-8020-105-1000-5A-1	2277747	1
PACT MCR-V2-8020-105-1500-5A-1	2277750	1
PACT MCR-V2-8020-105-2000-5A-1	2276382	1
PACT MCR-V2- 8020-105	2277365	1
PACT MCR-V2C- 8020-105	2277501	1

Add **order key** from the selection table (ordering example marked in orange)

Order No.	Primary current I_{pn}	Secondary current I_{sn}	Class	Rated power S_n
2277352	IP25000	IS05	C10	P3000

Selection table PACT MCR-V2-8015-105 (Order No.: 2277352)

I_{sn}	Cl.	Primary rated current strength I_{pn} [A]											Rated power S_n [VA]		
		400	500	600	750	800	1000	1250	1500	1600	2000	2500			
IS01 ≈ 1 A	C05 ≈ 0.5	2.5	2.5	2.5	2.5	2.5	2.5	2.5	2.5	2.5	5	5	10	15	20
	C10 ≈ 1	5	5	5	5	5	5	5	5	10	10	15	15	20	25
	C05 ≈ 0.5	2.5	2.5	2.5	2.5	2.5	2.5	2.5	2.5	2.5	5	5	5	5	10
IS05 ≈ 5 A	C05 ≈ 0.5	5	5	5	5	5	5	5	5	5	5	5	5	5	10
	C10 ≈ 1	7.5	10	10	10	10	10	10	10	15	15	20	20	25	30
	C05 ≈ 0.5	2.5	2.5	2.5	2.5	2.5	5	5	5	5	5	5	5	5	10

Selection table PACT MCR-V2-8020-105 (Order No.: 2277365)

I_{sn}	Cl.	Primary rated current strength I_{pn} [A]									Rated power S_n [VA]				
		500	600	750	800	1000	1250	1500	1600	2000					
IS01 ≈ 1 A	C05 ≈ 0.5	2.5	2.5	2.5	2.5	2.5	2.5	2.5	2.5	2.5	5	5	10	15	20
	C10 ≈ 1	5	5	5	5	5	5	5	5	5	5	5	5	5	10
	C05 ≈ 0.5	2.5	2.5	2.5	2.5	2.5	2.5	2.5	2.5	2.5	2.5	2.5	2.5	2.5	5
IS05 ≈ 5 A	C05 ≈ 0.5	5	5	5	5	5	5	5	5	5	5	5	5	5	10
	C10 ≈ 1	7.5	10	10	10	10	10	10	10	10	10	10	10	15	20
	C05 ≈ 0.5	2.5	2.5	2.5	2.5	2.5	2.5	2.5	2.5	2.5	2.5	2.5	2.5	2.5	5

Monitoring

Current measurement

Current transformers

PACT MCR-V2-10020-129

- Primary rated current I_{pn} : 0...(400...4000) A
- Circular conductor dimensions: \varnothing 85 mm
- Rail dimensions: 2x100x10 mm, 80x64 mm

PACT MCR-V2-10036-129

- Primary rated current I_{pn} : 0...(400...4000) A
- Rail dimensions: 3x 100x12 mm



Window-type curr. transformer, official calibration as an option



Window-type curr. transformer, official calibration as an option

Notes:
Our configurator, which is available at phoenixcontact.net/products, makes ordering easy.
The relevant installation accessories can be found on page 233

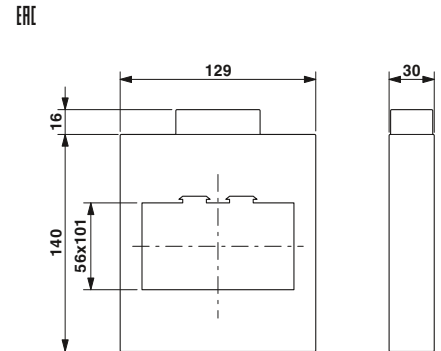
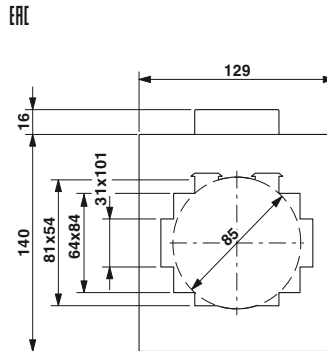

Description	Rated power S_n
Primary rated current I_{pn}:	
- 2500 A	15 VA
- 3000 A	15 VA
Current transformers , to determine the desired current transformer type, refer to the order key below	
Current transformers that support official calibration: To specify the type of current transformer you require, please refer to the order key (see notes)	

Ordering data		
Type	Order No.	Pcs./Pkt.
PACT MCR-V2-10020-129-2500-5A	2276395	1
PACT MCR-V2-10020-129	2277378	1
PACT MCR-V2C-10020-129	2277514	1

Ordering data		
Type	Order No.	Pcs./Pkt.
PACT MCR-V2-10036-129-3000-5A	2276405	1
PACT MCR-V2-10036-129	2277381	1
PACT MCR-V2C-10036-129	2277527	1

Add **order key** from the selection table (ordering example marked in orange)

Order No.	Primary current I_{pn}	Secondary current I_{sn}	Class	Rated power S_n
2277378	IP40000	IS05	C05	P2500

Selection table PACT MCR-V2-10020-129 (Order No.: 2277378)

I_{sn}	Cl.	Primary rated current strength I_{pn} [A]													Rated power S_n [VA]			
		400	500	600	750	800	1000	1250	1500	1600	2000	2500	3000	4000				
IS01 ≅ 1 A	C05 ≅ 0.5	2.5	5	5	5	5	5	5	5	5	5	5	5	5	5	5	5	5
	C10 ≅ 1	5	5	10	10	10	10	10	10	10	10	10	10	10	10	10	10	10
IS05 ≅ 5 A	C05 ≅ 0.5	2.5	2.5	5	5	5	5	5	5	5	5	5	5	5	5	5	5	5
	C10 ≅ 1	5	5	10	10	10	10	10	10	10	10	10	10	10	10	10	10	10

Selection table PACT MCR-V2-10036-129 (Order No.: 2277381)

I_{sn}	Cl.	Primary rated current strength I_{pn} [A]													Rated power S_n [VA]			
		400	500	600	750	800	1000	1250	1500	1600	2000	2500	3000	4000				
IS01 ≅ 1 A	C05 ≅ 0.5	2.5	5	5	5	5	5	5	5	5	5	5	5	5	5	5	5	5
	C10 ≅ 1	5	5	10	10	10	10	10	10	10	10	10	10	10	10	10	10	10
IS05 ≅ 5 A	C05 ≅ 0.5	2.5	2.5	5	5	5	5	5	5	5	5	5	5	5	5	5	5	5
	C10 ≅ 1	5	5	10	10	10	10	10	10	10	10	10	10	10	10	10	10	10

Current transformers

PACT MCR-V2-12020-159

- Primary rated current I_{pn} : 0...(400...4000) A
- Circular conductor dimensions: \varnothing 96 mm
- Rail dimensions: 2x 120x10 mm, 3x 100x10 mm, 80x80 mm

PACT MCR-V2-12040-159

- Primary rated current I_{pn} : 0...(400...4000) A
- Rail dimensions: 4x 120x10 mm



Window-type current transformer



Window-type current transformer

ERC

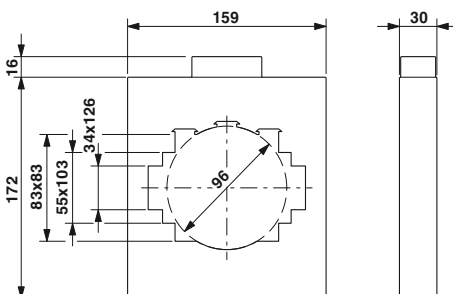

ERC

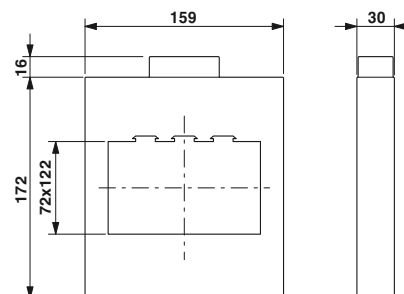

Notes:
Our configurator, which is available at phoenixcontact.net/products, makes ordering easy.
The relevant installation accessories can be found on page 233

Ordering data

Type	Order No.	Pcs./Pkt.
PACT MCR-V2-12020-159	2277394	1

Ordering data

Type	Order No.	Pcs./Pkt.
PACT MCR-V2-12040-159-4000-5A	2276418	1
PACT MCR-V2-12040-159	2277404	1

Description	Rated power S_n
Primary rated current I_{pn} : -4000 A	15 VA
Current transformers, to determine the desired current transformer type, refer to the order key below	

Add order key from the selection table (ordering example marked in orange)

Order No.	Primary current I_{pn}	Secondary current I_{sn}	Class	Rated power
2277404	IP08000	IS01	C05	P250

Selection table PACT MCR-V2-12020-159 (Order No.: 2277394)

I_{sn}	Cl.	Primary rated current strength I_{pn} [A]													Rated power S_n [VA]									
		400	500	600	750	800	1000	1250	1500	1600	2000	2500	3000	4000										
IS01 ≅ 1 A	C05 ≅ 0.5	2.5	2.5	2.5	2.5	2.5	2.5	5	5	5	5	5	5	5	10	15	15	15	15	15	30	30	30	45
	C10 ≅ 1	2.5	5	5	2.5	2.5	5	5	5	5	5	5	5	10	10	10	15	15	15	15	30	30	45	45
	C05 ≅ 0.5	2.5	2.5	2.5	2.5	2.5	5	5	5	5	5	5	5	10	10	10	15	15	15	15	30	30	45	45
IS05 ≅ 5 A	C05 ≅ 0.5	2.5	5	5	5	5	5	10	10	10	10	10	10	10	15	15	15	15	15	30	30	45	45	
	C10 ≅ 1	2.5	5	5	5	5	5	10	10	10	10	10	10	15	15	15	15	15	15	30	30	45	45	
	C05 ≅ 0.5	2.5	5	5	5	5	5	10	10	10	10	10	10	15	15	15	15	15	15	30	30	45	45	

Selection table PACT MCR-V2-12040-159 (Order No.: 2277404)

I_{sn}	Cl.	Primary rated current strength I_{pn} [A]													Rated power S_n [VA]								
		400	500	600	750	800	1000	1250	1500	1600	2000	2500	3000	4000									
IS01 ≅ 1 A	C05 ≅ 0.5	2.5	2.5	2.5	2.5	2.5	2.5	5	5	5	5	5	5	5	5	10	10	10	10	10	10	15	15
	C10 ≅ 1	2.5	5	5	2.5	2.5	5	5	5	5	5	5	5	10	10	10	15	15	15	15	30	30	30
	C05 ≅ 0.5	2.5	2.5	2.5	2.5	2.5	5	5	5	5	5	5	5	10	10	10	15	15	15	15	30	30	30
IS05 ≅ 5 A	C05 ≅ 0.5	2.5	5	5	5	5	5	10	10	10	10	10	10	10	15	15	15	15	15	30	30	45	45
	C10 ≅ 1	2.5	5	5	5	5	5	10	10	10	10	10	10	15	15	15	15	15	15	30	30	45	45
	C05 ≅ 0.5	2.5	5	5	5	5	5	10	10	10	10	10	10	15	15	15	15	15	15	30	30	45	45

Monitoring

Current measurement

Current transformers

PACT MCR-V3-60

– Primary rated current I_{pn} :
0...(1...40) A

– Current-carrying copper lines connected directly to the screw terminal blocks on the primary side

Notes:
Our configurator, which is available at phoenixcontact.net/products, makes ordering easy.
The relevant installation accessories can be found on page 233

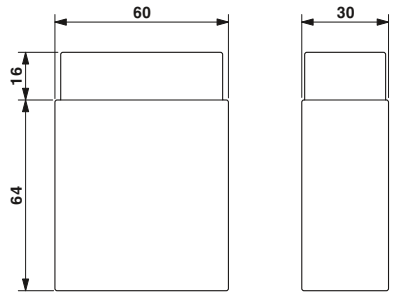

Winding current transformer

ERC

Description
Current transformers , to determine the desired current transformer type, refer to the order key below

Ordering data		
Type	Order No.	Pcs./Pkt.
PACT MCR-V3-60	2277417	1

Add **order key** from the selection table (ordering example marked in orange)

Order No.	Primary current I_{pn}	Secondary current I_{sn}	Class	Rated power S_n
2277417	IP00025	IS01	C10	P250

Selection table PACT MCR-V3-60 (Order No.: 2277417)

I_{sn}	Cl.	Primary rated current strength I_{pn} [A]														Rated power S_n [VA]
		1	2	2.5	4	5	6	7.5	10	12.5	15	20	25	30	40	
IS01 ≅ 1 A	C05 ≅ 0.5	2.5	2.5	2.5	2.5	2.5	2.5	2.5	2.5	2.5	2.5	2.5	2.5	2.5	2.5	2.5
	C10 ≅ 1	5	5	5	5	5	5	5	5	5	5	5	5	5	5	
IS05 ≅ 5 A	C05 ≅ 0.5	2.5	2.5	2.5	2.5	2.5	2.5	2.5	2.5	2.5	2.5	2.5	2.5	2.5	2.5	2.5
	C10 ≅ 1	5	5	5	5	5	5	5	5	5	5	5	5	5	5	

Accessories

Quick-action mechanism for PACT current transformers

- No tools necessary for mounting
- Extremely easy handling, thanks to secure fastening by pressing with finger
- Set consisting of two fixing pins and a holding latch

Notes:
The 16 mm wide quick-action mechanism can also be used for larger current transformers if the length of the fixing pins is sufficient.



for: ...-V2-4012-70..., ...-V2-5012-85...



for: ...-V2-3015-60..., ...-V2-6015-85..., ...-V2-6315-95...

Technical data		
General data		
Ambient temperature (operation)	-25 °C ... 120 °C	
Width of the retaining bracket [mm]	13	
Ordering data		
Type	Order No.	Pcs./Pkt.
PACT-FAST-MNT-W13-L65	2276625	1
PACT-FAST-MNT-W13-L40	2276612	1

Technical data		
General data		
Ambient temperature (operation)	-25 °C ... 120 °C	
Width of the retaining bracket [mm]	16	
Ordering data		
Type	Order No.	Pcs./Pkt.
PACT-FAST-MNT-W16-L65	2276641	1
PACT-FAST-MNT-W16-L40	2276638	1

General data	
Ambient temperature (operation)	-25 °C ... 120 °C
Width of the retaining bracket [mm]	13
Description	
Quick-action mechanism	
Fixing pin length 65 mm	
Fixing pin length 40 mm	
Quick-action mechanism	
Fixing pin length 65 mm	
Fixing pin length 40 mm	

Accessories

- Copper sleeves
- DIN rail adapter
- Secondary terminal cover
- Insulating caps



Copper sleeves
DIN rail adapter

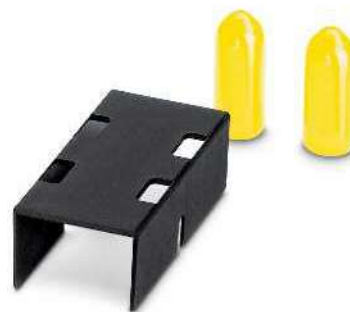

Secondary terminal cover
Insulating caps

Ordering data		
Type	Order No.	Pcs./Pkt.
PACT MCR-CB-21- 8	2277569	1
PACT MCR-CB-21-12	2277556	1
PACT MCR-CB-28-12	2277543	1
PACT MCR-CB-42-12	2277530	1
PACT MCR-RA	2277598	12

Ordering data		
Type	Order No.	Pcs./Pkt.
PACT MCR-ETC-60	2277572	9
PACT MCR-ETC-75	2277585	9
PACT MCR-ICAP	2277608	18

Description	
Copper sleeves , for establishing a conductive connection during the horizontal assembly of PACT analog current transformers. The size of the copper sleeve depends on the diameter of the inner hole of the current transformer.	
- for PACT MCR-V1-21-44-...	Ø 21/8 mm
- for PACT MCR-V1-21-44-...	Ø 21/12 mm
- for PACT MCR-V2-3015-60-...	Ø 28/12 mm
- for PACT MCR-V2-5012-85-...	Ø 42/12 mm
DIN rail adapter	
Secondary terminal cover , for increasing the clearances and creepage distances	
	Length: 60 mm
	Length: 75 mm
Insulating caps	
for protection against unintended contact with mounting screws of the primary rail	



Fast installation in a confined space

PACT RCP current transformers for retrofitting can be conveniently mounted where there is not enough space for split core current transformers. System downtimes are reduced as system parts do not have to be removed for installation.

Your advantages:

- High system availability due to reduced downtimes: fast installation without removing system parts
- Safe installation and operation: no dangerous open circuit voltages
- No magnetic saturation
- High linearity, even at high currents
- Responds to fast current changes
- The coil is protected against electromagnetic interference
- The current can rise up to the short-circuit current without necessarily destroying the coil
- High nominal isolation voltage

Professional holding device for busbars

The PACT RCP-CLAMP holding device offers the following advantages:

- Suitable for industrial applications
- Steel bracket ensures permanent fixed seating at high busbar temperatures
- Designed for rails with a thickness of 10 to 15 mm
- Rogowski coil is snapped onto the fixing element
- Rogowski coil has a safe and defined place on the busbar
- Rogowski coil can be rotated in 15° increments for optimum alignment.
- PACT RCP avoids direct contact of the measuring coil with its own or adjacent busbar
- This allows installations on warm busbars to remain under control



Easy and safe installation

Simply place the handy Rogowski coil quickly around busbars and circular conductors. The measuring transducer connected downstream supplies the same typical secondary currents as a standard current transformer.



Fast installation in a confined space

PACT RCP current transformers save space and are handy as the size and weight of the Rogowski coil are not dependent on the amperage and unlike split core current transformers, remain the same.



One measuring system for all amperages

Acquire alternating currents up to 4000 A using a single coil type. Rogowski coils are available in three different lengths for optimum adjustment to the busbar and circular conductor dimensions.



Eight current measuring ranges

The measuring transducer connected downstream supplies the same typical secondary currents as a standard current transformer. Choose between eight different current measuring ranges via DIP switches. For optimum measuring accuracy, compensate for the different coil lengths by simply using a potentiometer.



Detect harmonics and transients

PACT RCP current transformers for retrofitting cover a large frequency range from 10 to 5000 Hz. You can therefore measure harmonics and transients with phase accuracy.



Safe seating

The optional holding device ensures safe seating and optimal alignment of the coil even on very hot busbars. If the gap between the busbars is very small, simply turn the coil diagonally to avoid touching other rails.

Monitoring

Current measurement

Current transformers for retrofitting

PACT RCP

- Practical handling due to the flexible measuring coil for opening
- Universal application possibilities thanks to 8 different current measuring ranges in one device: (0 ... 100/ ... / ... /4000 A)
- The large bandwidth from 10 to 5000 Hz enables harmonics and transients to be detected
- It is not possible for dangerous open circuit voltages to occur
- The bracket ensures optimum alignment of the measuring coil to the busbar
- Low space requirement in the control cabinet



Current transformer for subsequent installation in the field

Technical data	
Measuring coil input data	
Frequency range	40 Hz ... 20000 Hz
Position error	< 1 %
Measuring coil signal output	
Output signal (at 50 Hz)	100 mV (no load, at 1,000 A)
General data, measuring coil	
Length of signal cable	3000 mm
Rated insulation voltage	1000 V AC (rms CAT III) 600 V AC (rms CAT IV)
Test voltage	10.45 kV (DC / 1 min.)
Ambient temperature (operation)	-30 °C ... 80 °C (Measuring coil)
Ambient temperature (storage/transport)	-40 °C ... 80 °C (Measuring coil)
Measuring transducer input data	
Measuring ranges (current) via DIP switch	100 A , 250 A , 400 A , 630 A , 1000 A , 1500 A , 2000 A , 4000 A
Phase angle	< 1 °
Measuring transducer signal input	
Input signal (at 50 Hz)	100 mV (1000 A)
Measuring transducer signal output	
Current output signal	0 A AC ... 1 A
Miscellaneous data for measuring transducer	
Nominal supply voltage	24 V DC -20 % ... +25 %
Nominal supply voltage range	19.2 V DC ... 30 V DC
Transmission error, maximum	≤ 0.5 % (From the range end value)
Linearity error	< 0.5 % (From the range end value)
Frequency range	45 Hz ... 65 Hz
Degree of protection	IP20
Test voltage	1.5 kV AC (Supply/input and output: 50 Hz, 1 min)
Dimensions W/H/D	22.5 / 70.4 / 85 mm
Ambient temperature (operation)	-20 °C ... 70 °C (Measuring transducer)
Ambient temperature (storage/transport)	-25 °C ... 85 °C (Measuring transducer)
General data for the set	
Altitude	< 2000 m
Permissible humidity (operation)	5 % ... 95 % (non-condensing)
Approvals/conformities	
Standards/specifications	IEC 61010-1 IEC 61010-2-032

Description
Current transformer for retrofitting , set consisting of Rogowski coil and measuring transducer, output signal: 1 A AC (effective for sine)
Length of measuring coil 300 mm
Length of measuring coil 450 mm
Length of measuring coil 600 mm

Holding device for busbar
for busbar thicknesses of 5 to 10 mm
for busbar thicknesses of 10 to 15 mm

Ordering data		
Type	Order No.	Pcs./Pkt.
PACT RCP-4000A-1A-D95	2904921	1
PACT RCP-4000A-1A-D140	2904922	1
PACT RCP-4000A-1A-D190	2904923	1

Accessories		
	Order No.	Pcs./Pkt.
PACT RCP-CLAMP-5-10	2907888	1
PACT RCP-CLAMP	2904895	1

Recommendations for the use of coil lengths and busbar dimensions

Busbar	Diameter/ coil length	1 busbar per phase	2 busbars per phase	3 busbars per phase
[mm x mm]	[mm]			
30 x 10	95/300	X	X	
40 x 10	95/300	X	X	
40 x 10	140/450			X
50 x 10	95/300	X		
50 x 10	140/450		X	X
60 x 10	95/300	X		
60 x 10	140/450		X	X
60 x 10	140/450	X	X	X
100 x 10	140/450	X	X	
100 x 10	190/600			X
120 x 10	140/450	X		
120 x 10	190/600		X	X
160 x 10	190/600	X	X	X

Current transformers for retrofitting

PACT RCP

- Universal application possibilities thanks to 8 different current measuring ranges in one device: (0 ... 100/ ... / ... /4000 A)
- Detection of harmonics and transients in the frequency range from 16 to 1000 Hz
- Large number of different standard signals on output side
- Freely configurable 4-way signal conditioner with switching output
- FASTCON Pro plug-in connection system
- Overall width of just 6.2 mm
- Easy configuration e.g., via DIP switches, programmable software, via smartphone app or FDT/DTM



Current transformer for subsequent installation in the field

Technical data	
Measuring coil input data	
Frequency range	40 Hz ... 20000 Hz
Position error	< 1 %
Measuring coil signal output	
Output signal (at 50 Hz)	100 mV (no load, at 1,000 A)
General data, measuring coil	
Length of signal cable	3000 mm
Rated insulation voltage	1000 V AC (rms CAT III) 600 V AC (rms CAT IV)
Test voltage	10.45 kV (DC / 1 min.)
Ambient temperature (operation)	-30 °C ... 80 °C (Measuring coil)
Measuring transducer input data	
Measuring ranges (current) via DIP switch	100 A , 250 A , 400 A , 630 A , 1000 A , 1500 A , 2000 A , 4000 A
Measuring transducer signal input	
Input signal (at 50 Hz)	100 mV (1000 A)
Measuring transducer signal output	
Current output signal	0 mA ... 20 mA (via DIP switch) 4 mA ... 20 mA (via DIP switch) 0 mA ... 10 mA (via DIP switch) 2 mA ... 10 mA (via DIP switch) 0 mA ... 21 mA (Can be set via software)
Output signal	
Voltage	0 V ... 10 V (via DIP switch) 2 V ... 10 V (via DIP switch) 0 V ... 5 V (via DIP switch) 1 V ... 5 V (via DIP switch) 0 V ... 10.5 V (Can be set via software)
Miscellaneous data for measuring transducer	
Nominal supply voltage	24 V DC
Nominal supply voltage range	9.6 V DC ... 30 V DC
Transmission error, maximum	≤ 0.5 % (From the range end value)
Frequency range	16 Hz ... 1000 Hz
Degree of protection	IP20
Test voltage	3 kV (50 Hz, 1 min.)
Dimensions W/H/D	6.2 / 110.5 / 120.5 mm
Ambient temperature (operation)	-40 °C ... 70 °C (Measuring transducer)
General data for the set	
Altitude	> 4000 m
Permissible humidity (operation)	5 % ... 95 % (non-condensing)
Approvals/conformities	
Standards/specifications	IEC 61010-1 IEC 61010-2-032

Ordering data			
Description	Type	Order No.	Pcs./Pkt.
Current transformer with screw connection for retrofitting , set consisting of Rogowski coil and 4-way signal conditioner with switching output			
Length of measuring coil 300 mm			
Length of measuring coil 450 mm			
Length of measuring coil 600 mm			
Current transformer with Push-in connection for retrofitting , set consisting of Rogowski coil and 4-way signal conditioner with switching output			
Length of measuring coil 300 mm			
Length of measuring coil 450 mm			
Length of measuring coil 600 mm			
	PACT RCP-4000A-UIRO-D95	2906231	1
	PACT RCP-4000A-UIRO-D140	2906232	1
	PACT RCP-4000A-UIRO-D190	2906233	1
	PACT RCP-4000A-UIRO-PT-D95	2906234	1
	PACT RCP-4000A-UIRO-PT-D140	2906235	1
	PACT RCP-4000A-UIRO-PT-D190	2906236	1

Accessories			
Description	Type	Order No.	Pcs./Pkt.
Holding device for busbar for busbar thicknesses of 5 to 10 mm	PACT RCP-CLAMP-5-10	2907888	1
for busbar thicknesses of 10 to 15 mm	PACT RCP-CLAMP	2904895	1



With flexible power supply – current transducers up to 12 A AC

Active current transducers convert sinusoidal alternating currents up to 12 A. The integrated wide-range power supply unit enables use in various different countries.

With hinged Rogowski sensor – current transducers up to 200 A AC

The AC current transducers measure sinusoidal and non-sinusoidal alternating currents up to 200 A. The hinged Rogowski sensor ensures very easy installation, as cables that are to be measured do not have to be isolated. This enables mounting to be carried out without interruptions.

Limit value monitoring with the current protector

At the current protector, a desired amperage is specified at which a PDT contact switches a load on or off.

Flexible signal conditioning – current transducers up to 55 A AC/DC

Current transducers up to 55 A offer an infinitely adjustable measuring range. This range is mapped over the entire output signal range. This ensures extremely accurate resolution of measured values. Basic configuration can be performed quickly via the DIP switches. Additional useful device functions can be set via the software.

For high currents – current transducers up to 600 A AC/DC

The universal current transducers are the ideal solution for measuring high currents with any waveform up to 600 A AC/DC. The product range offers various different devices in graded measuring ranges with current or voltage output.



For sinusoidal alternating currents up to 12 A

- 3-way electrical isolation
- Wide-range version from 19.2 to 253 V AC/DC
- Voltage bridging with DIN rail connector
- Input and output can be configured via DIP switches
- Suitable for potentially explosive areas, thanks to ATEX approval for Ex Zone 2



For sinusoidal and non-sinusoidal alternating currents up to 200 A

- Distorted alternating currents up to 6000 Hz can be also acquired, thanks to true r.m.s. value measurement (RMS)
- Uninterrupted installation and lossless current measurement thanks to hinged Rogowski sensor
- Measuring range selection with slide switch



Limit value monitoring

- The current protector converts sinusoidal alternating currents to binary switching signals.
- Switching point can be freely selected in the measuring range from 0 to 16 A AC
 - Relay PDT output
 - Adjustable switch hysteresis
 - 3-way isolation
 - Settable operating current / quiescent current behavior



With flexible measuring ranges for all waveforms up to 55 A

- Lossless true r.m.s. value measurement without shunt via Hall sensor (TRMS)
- Optimum mapping of the measuring range up to 55 A, thanks to software-programmable upper and lower limits
- Limit value alarm in the event of threshold value overrange or underrange up to 55 A
 - via relay or transistor output



For high currents – current transducers up to 600 A AC/DC

- Lossless true r.m.s. value measurement without shunt via Hall sensor (TRMS)
- Compact dimensions also enable distributed use
- Variable mounting on DIN rail and mounting plate
- COMBICON plug-in connection terminal blocks
- 3-way isolation
- For a conductor diameter of up to 32 mm

Monitoring

Current measurement

Current transducers for AC, DC, and distorted currents

- The **MCR-SL-CUC-...** current transducers measure DC, AC, and distorted currents from 0 to 600 A.
- Universal current measurement, no shunt required
 - Compact dimensions also enable distributed use
 - Variable mounting on DIN rail and mounting plate
 - Simple connection method thanks to COMBICON plug-in connection terminal blocks
 - 3-way isolation



For DC, AC, and distorted currents of 0 ... 300 A, voltage output

Housing width 90 mm

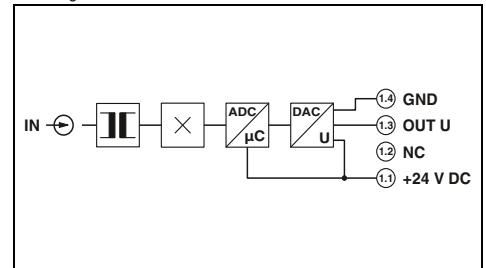

Technical data

Input data	
Frequency range	20 Hz ... 6000 Hz (0 Hz)
Curve type	AC, DC or distorted currents
Connection method	Cable design: 32 mm diameter
Output data	
Output signal	0 ... 10 V
Maximum output signal	
Load R_B	$\geq 10 \text{ k}\Omega$
General data	
Supply voltage U_B	20 V DC ... 30 V DC
Maximum transmission error	$< \pm 1 \%$ (of final value)
Temperature coefficient	typ. 0.02 %/K (0 ... 60°C) 0.04 %/K (-40 ... 65 °C)
Step response (10-90%)	150 ms
Safe isolation	acc. to EN 61010
Rated insulation voltage	300 V AC
Surge voltage category/degree of pollution	III / 2
Degree of protection	IP20
Ambient temperature range	-40 °C ... 65 °C
Dimensions W/H/D	90 / 33.8 / 85 mm
Spring-cage connection (solid/stranded/AWG)	0.25 ... 2.5 mm ² / 0.2 ... 2.5 mm ² / 24 - 12
Conformance/Approvals	
Conformance	CE-compliant
UL, USA/Canada	UL/C-UL listed UL 508

Ordering data

Description	Overload capacity	Type	Order No.	Pcs./Pkt.
Universal current transducer				
Input current range: 0 ... 100 A	$6 \times I_{IN}$	MCR-SL-CUC-100-U	2308108	1
Input current range: 0 ... 200 A	$3 \times I_{IN}$	MCR-SL-CUC-200-U	2308205	1
Input current range: 0 ... 300 A	$3.33 \times I_{IN}$	MCR-SL-CUC-300-U	2308302	1
Input current range: 0 ... 400 A	$2.5 \times I_{IN}$			
Universal current transducer without UL approval				
Input current range: 0 ... 500 A	$3.6 \times I_{IN}$			
Input current range: 0 ... 600 A	$3 \times I_{IN}$			



For DC, AC, and distorted currents of
0 ... 600 A,
current output



Housing width 90 mm

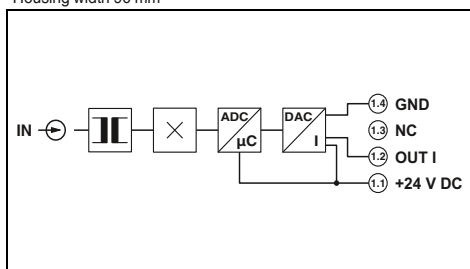

Technical data

20 Hz ... 6000 Hz (0 Hz)
AC, DC or distorted currents
Cable design: 32 mm diameter

4 ... 20 mA
< 25 mA
< 300 Ω

20 V DC ... 30 V DC
<± 1 % (of final value)
typ. 0.02 %/K (0 ... 60°C) 0.04 %/K (-40 ... 65 °C)

150 ms
acc. to EN 61010
300 V AC
III / 2
IP20
-40 °C ... 65 °C
90 / 33.8 / 85 mm
0.25 ... 2.5 mm² / 0.2 ... 2.5 mm² / 24 - 12

CE-compliant
UL/C-UL listed UL 508

Ordering data

Type	Order No.	Pcs./Pkt.
MCR-SL-CUC-100-I	2308027	1
MCR-SL-CUC-200-I	2308030	1
MCR-SL-CUC-300-I	2308043	1
MCR-SL-CUC-400-I	2308072	1
MCR-SL-CUC-500-I	2308085	1
MCR-SL-CUC-600-I	2308098	1

Monitoring

Current measurement

Current transducers for AC, DC, and distorted currents

The **MCR-S...-UI(-SW)-DCI** current transducers measure direct, alternating, and distorted currents.

- Device can be set via DIP switches or MCR/PI-CONF-WIN configuration software
- True r.m.s. value measurement
- 3-way isolation
- With optional relay and transistor output

Notes:

To order a configurable product, please enter the desired configuration using the order key, see page 244

Further information about the configuration software can be found on page 251



For DC, AC, and distorted currents
0 ... 11 A



Ex: II

Housing width 22.5 mm

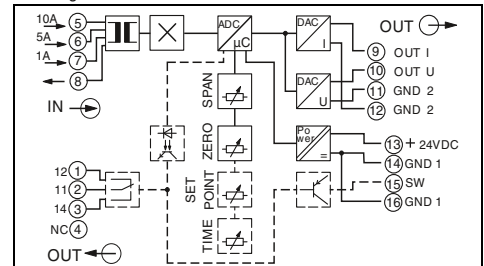

Technical data

Input data		
Input current		0 A ... 11 A (AC/DC)
Operate threshold		2 % (of measuring range nominal value 1/5/10 A)
Frequency range		15 Hz ... 400 Hz
Curve type		AC, DC or distorted currents
Overload capacity		2 x I _N (continuous)
Surge strength		20 x I _N (1 s)
Connection method		Screw connection
Output data		
Output signal (normal and inverse)		U output I output
		0 ... 5 V / 1 ... 5 V / 0 ... 10 V 0 ... 20 mA / 4 ... 20 mA
		2 ... 10 V / -5 ... 5 V / -10 ... 10 V
		> 10 kΩ < 500 Ω
Load R _B		
Switching output		
Relay output	Contact material	1 PDT / AgSnO, hard gold-plated
	Maximum switching current	50 mA (for gold layer, 30 V AC/ 36 V DC) 2 A (in case of a destroyed gold layer, 250 V AC)
	Output voltage	19 V ... 29 V (supply voltage - 1 V)
Transistor output pnp	Continuous load current	80 mA (Not short-circuit-proof)
	Setting range of the threshold value	1 % ... 110 %
	Response delay	0.1 s ... 20 s
	Status indication	Yellow LED
General data		
Supply voltage U _B		20 V DC ... 30 V DC
Current consumption		< 50 mA (without load)
Maximum transmission error		< 0.5 % (of nominal range value under nominal conditions)
Temperature coefficient		typ. < 0.025 %/K
Step response (10-90%)		330 ms (with AC) 40 ms (with DC)
Safe isolation		acc. to EN 50178, EN 61010
Rated insulation voltage		300 V AC (to ground)
Surge voltage category/degree of pollution		III / 2
Test voltage input/output		4 kV (50 Hz, 1 min.)
Test voltage input/power supply		4 kV (50 Hz, 1 min.)
Test voltage output/power supply		500 V (50 Hz, 1 min.)
Degree of protection		IP20
Dimensions W/H/D		22.5 / 99 / 114.5 mm
Screw connection solid/stranded/AWG		0.2 ... 2.5 mm ² / 0.2 ... 2.5 mm ² / 24 - 14
EMC note		Class A product, see page 605
Conformance/Approvals		
Conformance		CE-compliant
UL, USA/Canada		Class I, Zone 2, AEx nA nC IICT4, Ex nA nC IIC T4 Gc X

Ordering data

Description	Type	Order No.	Pcs./Pkt.
MCR current transducer for measuring AC, DC, and distorted currents with relay and transistor switching output			
Configurable product	MCR-S-1-5-UI-SW-DCI	2814650	1
Standard product	MCR-S-1-5-UI-SW-DCI-NC	2814731	1
Configurable product, without switching output	MCR-S-1-5-UI-DCI	2814634	1
Standard product, without switching output	MCR-S-1-5-UI-DCI-NC	2814715	1

new



For DC, AC, and distorted currents
0 ... 55 A



For DC, AC, and distorted currents
0 to 100 A

Ex:
Housing width 22.5 mm

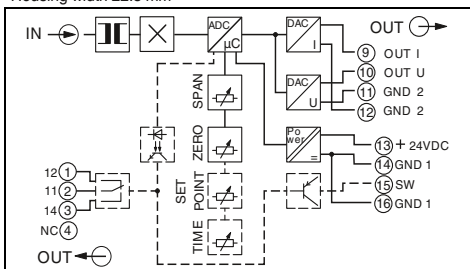

Housing width 22.5 mm

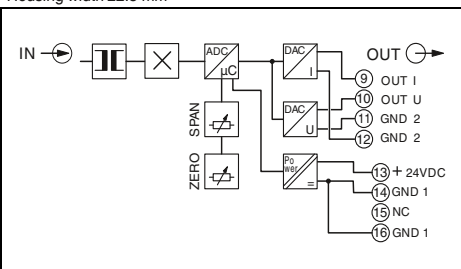

Technical data

0 A ... 55 A (AC/DC)
1 % (of measuring range nominal value 50 A)
15 Hz ... 400 Hz
AC, DC or distorted currents
Depending on through connected conductor
Depending on through connected conductor
Through connection, diameter 10.5 mm
U output I output
0 ... 5 V / 1 ... 5 V / 0 ... 10 V 0 ... 20 mA / 4 ... 20 mA
2 ... 10 V / -5 ... 5 V / -10 ... 10 V
> 10 kΩ < 500 Ω
1 PDT / AgSnO, hard gold-plated
50 mA (for gold layer, 30 V AC / 36 V DC)
2 A (in case of a destroyed gold layer, 250 V AC)
19 V ... 29 V (supply voltage - 1 V)
80 mA (Not short-circuit-proof)
1 % ... 110 %
0.1 s ... 20 s
Yellow LED

Technical data

-100 A ... 100 A (AC/DC)
1 % (of measuring range nominal value 100 A)
15 Hz ... 400 Hz
AC, DC or distorted currents
Depending on through connected conductor
Depending on through connected conductor
Through connection, diameter 10.5 mm
U output I output
0 ... 5 V / 1 ... 5 V / 0 ... 10 V 0 ... 20 mA / 4 ... 20 mA
2 ... 10 V / -5 ... 5 V / -10 ... 10 V
> 10 kΩ < 500 Ω
- / -
-
-
-
-
-

20 V DC ... 30 V DC
< 50 mA (without load)
< 0.5 % (of nominal range value under nominal conditions)
typ. < 0.025 %/K
330 ms (with AC) 40 ms (with DC)
acc. to EN 50178, EN 61010
300 V AC (to ground)
III / 2
4 kV (50 Hz, 1 min.)
4 kV (50 Hz, 1 min.)
500 V (50 Hz, 1 min.)
IP20
22.5 / 99 / 114.5 mm
0.2 ... 2.5 mm² / 0.2 ... 2.5 mm² / 24 - 14
Class A product, see page 605

20 V DC ... 30 V DC
< 40 mA (without load)
< 0.5 % (of nominal range value under nominal conditions)
typ. < 0.025 %/K
330 ms (AC) 40 ms (DC)
acc. to EN 50178, EN 61010
300 V AC (to ground)
III / 2
4 kV (50 Hz, 1 min.)
4 kV (50 Hz, 1 min.)
500 V (50 Hz, 1 min.)
IP20
22.5 / 99 / 114.5 mm
0.2 ... 2.5 mm² / 0.2 ... 2.5 mm² / 24 - 14
Class A product, see page 605

CE-compliant
Class I, Zone 2, AEx nA nC IIC T4, Ex nA nC IIC T4 Gc X

CE-compliant
Class I, Zone 2, AEx nA nC IIC T4, Ex nA nC IIC T4 Gc X

Ordering data

Ordering data

Type	Order No.	Pcs./ Pkt.
MCR-S-10-50-UI-SW-DCI	2814663	1
MCR-S-10-50-UI-SW-DCI-NC	2814744	1
MCR-S-10-50-UI-DCI	2814647	1
MCR-S-10-50-UI-DCI-NC	2814728	1

Type	Order No.	Pcs./ Pkt.
MCR-S-20-100-UI-DCI	2908798	1

Monitoring

Current measurement

Order key for current transducers (standard configuration entered as an example)

Order No.	Measuring range:		Output	Threshold value	Suppression time	Switching behavior of relay and transistor	
	Start	End				A	O
2814634	0.00	5.00	OUT01				
2814650	0.00	5.00	OUT01	50	3.0	A	O
2814634 ≙ MCR-S-1-5-UI-DCI	Measuring range initial value between 0.00 ... 7.50 A	Measuring range final value between 0.2 ... 11 A	OUT01 ≙ 0 ... 20 mA OUT02 ≙ 4 ... 20 mA OUT03 ≙ 0 ... 10 V OUT04 ≙ 2 ... 10 V OUT05 ≙ 0 ... 5 V OUT06 ≙ 1 ... 5 V OUT07 ≙ 20 ... 0 mA OUT08 ≙ 20 ... 4 mA OUT09 ≙ 10 ... 0 V OUT10 ≙ 10 ... 2 V OUT11 ≙ 5 ... 0 V OUT12 ≙ 5 ... 1 V OUT13 ≙ -5 ... +5 V OUT14 ≙ -10 ... +10 V OUT17 ≙ +10 ... -10 V OUT18 ≙ +5 ... -5 V	Switching threshold between 1 ... 110% 50 ≙ 50% of the set measuring range final value (here 2.5 A)	between 0.1 ... 20 s 3.0 ≙ 3 s	A ≙ Operating- current- controlled R ≙ Closed- circuit- current- controlled	O ≙ Overrange U ≙ Underrange
2814650 ≙ MCR-S-1-5-UI-SW-DCI	0.00 ≙ 0.00 A	5.00 ≙ 5.00 A					

Order No.	Measuring range:		Output	Threshold value	Suppression time	Switching behavior of relay and transistor	
	Start	End				A	O
2814647	0.0	50.0	OUT01				
2814663	0.0	50.0	OUT01	50	3.0	A	O
2814647 ≙ MCR-S-10-50-UI-DCI	Measuring range initial value between 0.0 ... 37.5 A	Measuring range final value between 9.5 ... 55 A	OUT01 ≙ 0 ... 20 mA OUT02 ≙ 4 ... 20 mA OUT03 ≙ 0 ... 10 V OUT04 ≙ 2 ... 10 V OUT05 ≙ 0 ... 5 V OUT06 ≙ 1 ... 5 V OUT07 ≙ 20 ... 0 mA OUT08 ≙ 20 ... 4 mA OUT09 ≙ 10 ... 0 V OUT10 ≙ 10 ... 2 V OUT11 ≙ 5 ... 0 V OUT12 ≙ 5 ... 1 V OUT13 ≙ -5 ... +5 V OUT14 ≙ -10 ... +10 V OUT17 ≙ +10 ... -10 V OUT18 ≙ +5 ... -5 V	Switching threshold between 1 ... 110% 50 ≙ 50% of the set measuring range final value (here 25 A)	between 0.1 ... 20 s 3.0 ≙ 3 s	A ≙ Operating- current- controlled R ≙ Closed- circuit- current- controlled	O ≙ Overrange U ≙ Underrange
2814663 ≙ MCR-S-10-50-UI-SW-DCI	0.0 ≙ 0.0 A	50.0 ≙ 50.0 A					

Order No.	Measuring range:		Output
	Start	End	
2908798	0.0	100.0	OUT01
2908798 ≙ MCR-S-20-100-UI-DCI	Measuring range initial value between 0.0 ... 75 A 0.0 ≙ 0.0 A	Measuring range final value between 19 ... 110 A 100 ≙ 100 A	OUT01 ≙ 0 ... 20 mA OUT02 ≙ 4 ... 20 mA OUT03 ≙ 0 ... 10 V OUT04 ≙ 2 ... 10 V OUT05 ≙ 0 ... 5 V OUT06 ≙ 1 ... 5 V OUT07 ≙ 20 ... 0 mA OUT08 ≙ 20 ... 4 mA OUT09 ≙ 10 ... 0 V OUT10 ≙ 10 ... 2 V OUT11 ≙ 5 ... 0 V OUT12 ≙ 5 ... 1 V OUT13 ≙ -5 ... +5 V OUT14 ≙ -10 ... +10 V OUT17 ≙ +10 ... -10 V OUT18 ≙ +5 ... -5 V

Function chart: switching behavior of relay and transistor output:

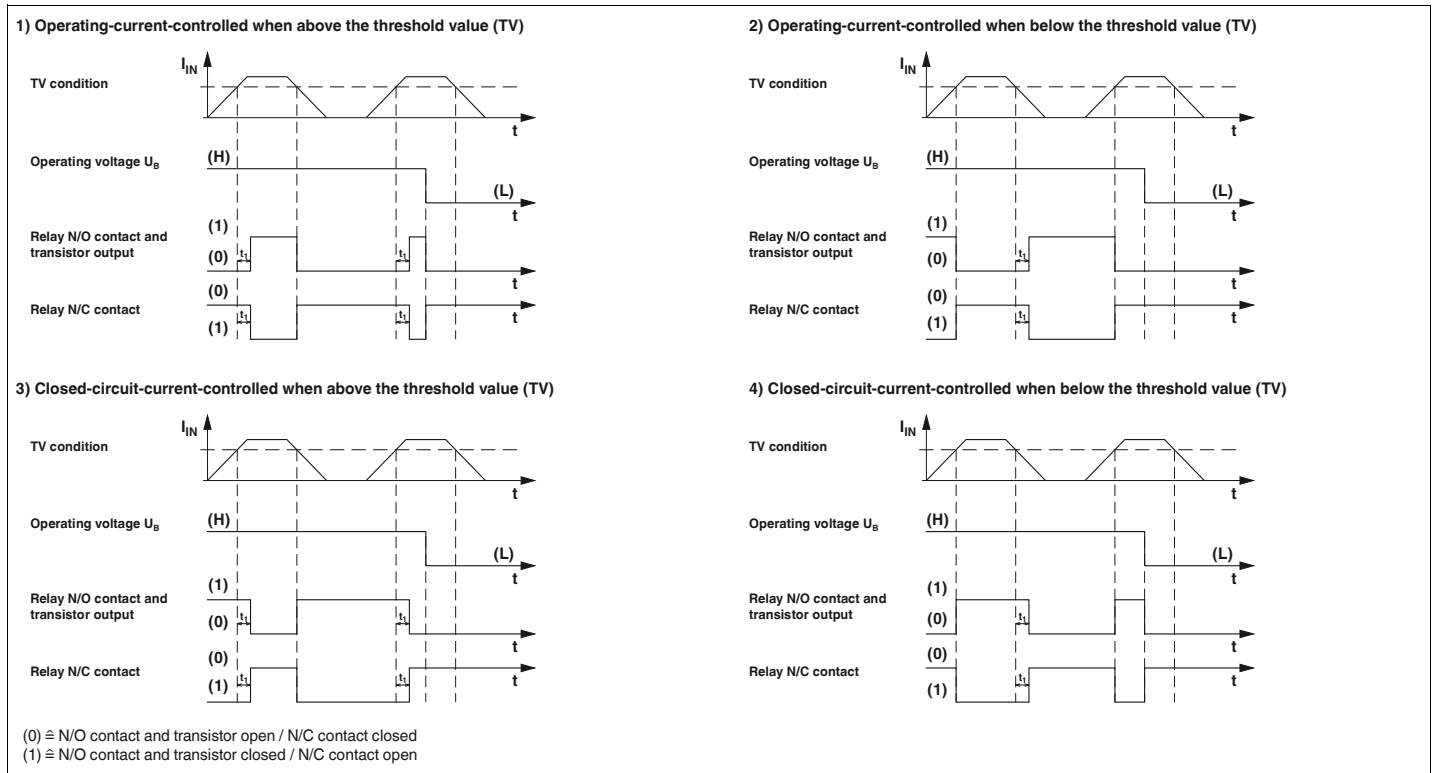

Monitoring

Current measurement

AC current transducers, sinusoidal

The **MCR-SL-CAC-...** current transducers measure sinusoidal alternating currents from 0 to 1/5/12 A.

- Wide range version from 19.2 to 253 V AC/DC
- 3-way isolation
- Input and output can be configured via DIP switches



For sinusoidal alternating currents
0 ... 1 A/0 ... 5 A



For sinusoidal alternating currents
0 ... 5 A/0 ... 12 A

ERL
Ex:
Housing width 22.5 mm

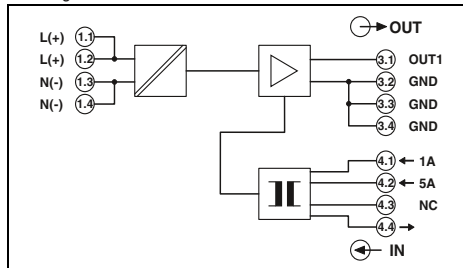

Technical data

Input data	
Input current (configurable)	0 A AC ... 1 A (configurable) / 0 A AC ... 5 A (configurable)
Nominal frequency	50 Hz
Frequency range	45 Hz ... 65 Hz
Curve type	Sine
Overload capacity	2 x I _N (continuous)
Surge strength	20 x I _N (1 s)
Connection method	Screw terminal block
Output data	
Output signal (configurable)	0 ... 20 mA / 4 ... 20 mA
Maximum output signal	25 mA
Load R _B	< 500 Ω (at 20 mA)
Ripple	< 10 mV _{pp} (for 500 Ω at 20 mA)
General data	
Supply voltage U _B	19.2 V DC ... 30 V DC
Current consumption	< 32 mA (at U _B =24 V DC, I _{OUT} =20 mA)
Maximum transmission error	≤ 0.5 % (of nominal range value under nominal conditions)
Temperature coefficient	< 0.02 %/K
Step response (10-90%)	max. 300 ms typ. 200 ms
Safe isolation	acc. to EN 61010
Rated insulation voltage	-
Overtoltage category Input/output	-
Degree of pollution	2
Test voltage input/output	4 kV (50 Hz, 1 min.)
Test voltage output/power supply	1.5 kV (50 Hz, 1 min.)
Degree of protection	IP20
Ambient temperature range	-20 °C ... 65 °C (-4 °F...149 °F)
Dimensions W/H/D	22.5 / 104 / 114.5 mm
Screw connection solid/stranded/AWG	0.2 ... 2.5 mm ² / 0.2 ... 2.5 mm ² / 24 - 14
Conformance/Approvals	
Conformance	CE-compliant
ATEX	II 3 G Ex nA IIC T4 Gc X
UL, USA/Canada	UL 508 Recognized

ERL
Ex:
Housing width 22.5 mm

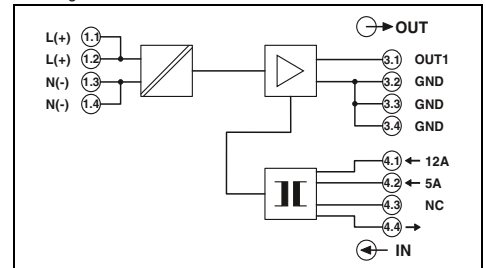

Technical data

	0 A AC ... 1 A (configurable) / 0 A AC ... 5 A (configurable)	0 A AC ... 5 A (configurable) / 0 A AC ... 12 A (configurable)
Nominal frequency	50 Hz	50 Hz
Frequency range	45 Hz ... 65 Hz	45 Hz ... 65 Hz
Curve type	Sine	Sine
Overload capacity	2 x I _N (continuous)	1 x I _N (continuous)
Surge strength	20 x I _N (1 s)	8 x I _N (1 s)
Connection method	Screw terminal block	Screw terminal block
Output data		
Output signal (configurable)	0 ... 20 mA / 4 ... 20 mA	0 ... 20 mA / 4 ... 20 mA
Maximum output signal	25 mA	25 mA
Load R _B	< 500 Ω (at 20 mA)	< 500 Ω (at 20 mA)
Ripple	< 10 mV _{pp} (for 500 Ω at 20 mA)	< 10 mV _{pp} (for 500 Ω at 20 mA)
General data		
Supply voltage U _B	19.2 V DC ... 30 V DC	19.2 V AC/DC ... 253 V AC/DC
Current consumption	< 32 mA (at U _B =24 V DC, I _{OUT} =20 mA)	< 30 mA (at U _B =24 V DC, I _{OUT} =20 mA)
Maximum transmission error	≤ 0.5 % (of nominal range value under nominal conditions)	≤ 0.5 % (of nominal range value under nominal conditions)
Temperature coefficient	< 0.02 %/K	< 0.02 %/K
Step response (10-90%)	max. 300 ms typ. 200 ms	max. 300 ms typ. 200 ms
Safe isolation	acc. to EN 61010	acc. to EN 61010
Rated insulation voltage	-	-
Overtoltage category Input/output	-	III
Degree of pollution	2	2
Test voltage input/output	4 kV (50 Hz, 1 min.)	4 kV (50 Hz, 1 min.)
Test voltage output/power supply	1.5 kV (50 Hz, 1 min.)	2 kV (50 Hz, 1 min.)
Degree of protection	IP20	IP20
Ambient temperature range	-20 °C ... 65 °C (-4 °F...149 °F)	-20 °C ... 65 °C (-4 °F...149 °F)
Dimensions W/H/D	22.5 / 104 / 114.5 mm	22.5 / 104 / 114.5 mm
Screw connection solid/stranded/AWG	0.2 ... 2.5 mm ² / 0.2 ... 2.5 mm ² / 24 - 14	0.2 ... 2.5 mm ² / 0.2 ... 2.5 mm ² / 24 - 14
Conformance/Approvals		
Conformance	CE-compliant	CE-compliant
ATEX	II 3 G Ex nA IIC T4 Gc X	II 3 G Ex nA IIC T4 Gc X
UL, USA/Canada	UL 508 Recognized	-

Ordering data

Description	Type	Order No.	Pcs./ Pkt.
MCR current transducer for sinusoidal alternating currents			
Supply voltage 19.2 ... 30 V DC	MACX MCR-SL-CAC- 5-I	2810612	1
Supply voltage 19.2 ... 253 V AC/DC	MACX MCR-SL-CAC- 5-I-UP	2810625	1

Accessories

DIN rail connector , for bridging the supply voltage (19.2...30 V DC), can be snapped on to 35 mm DIN rails according to EN 60715	ME 22,5 TBUS 1,5/ 5-ST-3,81 GN	2707437	50
--	---------------------------------------	----------------	----

Ordering data

Type	Order No.	Pcs./ Pkt.
MACX MCR-SL-CAC-12-I-UP	2810638	1

Accessories

--	--	--

AC current transducers, sinusoidal and distorted

The **MCR-SL-S-...00-...** current transducers measure sinusoidal and non-sinusoidal alternating currents within the range from 0 to 200 A.

- 30 to 6000 Hz true r.m.s. value measurement
- Measuring range selection with slide switch
- Loop-powered
- Can be retrofitted with the open-up Rogowski coil

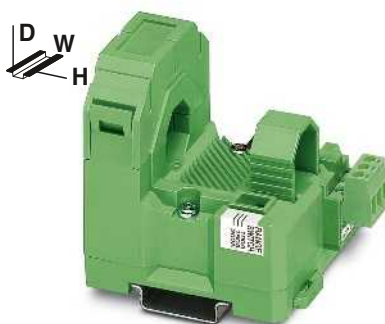

For sinusoidal and non-sinusoidal alternating currents, 0 ... 200 A, voltage output

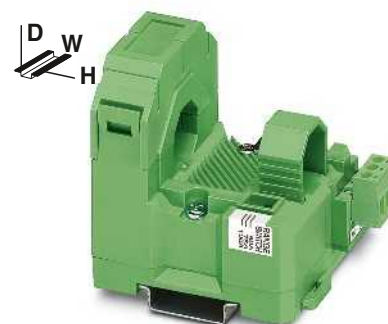

For sinusoidal and non-sinusoidal alternating currents, 0 ... 200 A, current output (loop-powered)

ERC
Ex:
Housing width 55 mm

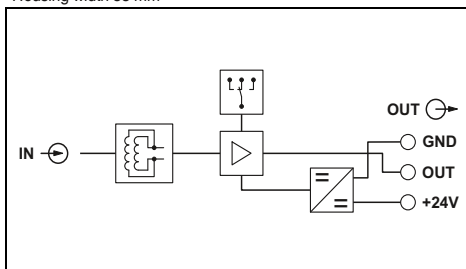

ERC
Ex:
Housing width 55 mm

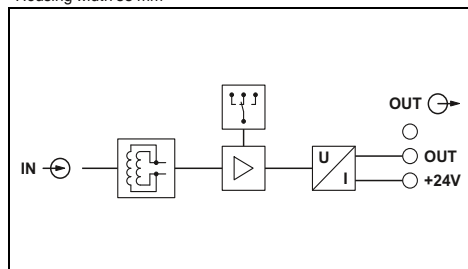

Technical data

Input data	...
Input current (configurable)	0 A ... 100 A (0...50/75/100 A)
Operate threshold	1 % (of final value)
Frequency range	30 Hz ... 6000 Hz
Curve type	Sinusoidal and non-sinusoidal
Overload capacity	Depending on laid conductor
Surge strength	Depending on through connected conductor
Connection method	Clamp-on cable design, diameter 18.5 mm
Output data	...
Output signal	0 ... 5 V / 0 ... 10 V
Maximum output signal	(0 V ... 10 V) 14 V, (0 V ... 5 V) 7 V
Load R _B	≥ 10 kΩ
General data	...
Supply voltage U _B	20 V DC ... 30 V DC
Current consumption	< 30 mA
Maximum transmission error	< 1 % (of final value)
Cable position error	< 0.63 %
Temperature coefficient	< 0.035 %/K
Step response (10-90%)	< 340 ms
Safe isolation	As per IEC 61010-1 and IEC 61326
Rated insulation voltage	300 V AC (to ground)
Surge voltage category/degree of pollution	III / 2
Test voltage input/output	5 kV (50 Hz, 1 min.)
Degree of protection	IP20
Ambient temperature range	-20 °C ... 60 °C
Dimensions W/H/D	55 / 85 / 70.5 mm
Screw connection solid/stranded/AWG	0.2 ... 2.5 mm ² / 0.2 ... 2.5 mm ² / 24 - 14
Conformance/Approvals	CE-compliant
Conformance	cULus
UL, USA/Canada	

...	...
...	0 A ... 200 A (0...100/150/200 A)
...	1 % (of final value)
...	30 Hz ... 6000 Hz
...	Sinusoidal and non-sinusoidal
...	Depending on laid conductor
...	Depending on through connected conductor
...	Clamp-on cable design, diameter 18.5 mm
...	0 ... 5 V / 0 ... 10 V
...	(0 V ... 10 V) 14 V, (0 V ... 5 V) 7 V
...	≥ 10 kΩ
...	20 V DC ... 30 V DC
...	< 30 mA
...	< 1 % (of final value)
...	< 0.63 %
...	< 0.035 %/K
...	< 340 ms
...	As per IEC 61010-1 and IEC 61326
...	300 V AC (to ground)
...	III / 2
...	5 kV (50 Hz, 1 min.)
...	IP20
...	-20 °C ... 60 °C
...	55 / 85 / 70.5 mm
...	0.2 ... 2.5 mm ² / 0.2 ... 2.5 mm ² / 24 - 14
...	CE-compliant
...	cULus

Technical data

...	...
...	0 A ... 200 A (0...100/150/200 A)
...	1 % (of final value)
...	30 Hz ... 6000 Hz
...	Sinusoidal and non-sinusoidal
...	Depending on laid conductor
...	Depending on through connected conductor
...	Clamp-on cable design, diameter 18.5 mm
...	4 ... 20 mA
...	< 25 mA
...	(U _B - 12 V) x 350 / 12 A
...	20 V DC ... 30 V DC
...	< 1 % (of final value)
...	< 0.63 %
...	< 0.025 %/K
...	< 340 ms
...	As per IEC 61010-1 and IEC 61326
...	300 V AC (to ground)
...	III / 2
...	5 kV (50 Hz, 1 min.)
...	IP20
...	-20 °C ... 60 °C
...	55 / 85 / 70.5 mm
...	0.2 ... 2.5 mm ² / 0.2 ... 2.5 mm ² / 24 - 14
...	CE-compliant
...	cULus

Ordering data

Description
MCR current transducer for sinusoidal and non-sinusoidal alternating currents
Input current range: 0...50/75/100 A
Input current range: 0...100/150/200 A

Type	Order No.	Pcs./Pkt.
MCR-SL-S-100-U	2813457	1
MCR-SL-S-200-U	2813460	1

Ordering data

Type	Order No.	Pcs./Pkt.
MCR-SL-S-100-I-LP	2813486	1
MCR-SL-S-200-I-LP	2813499	1

Monitoring

Current measurement

Passive AC current transducers, sinusoidal

The **MCR-SLP-1-5-UI-0** passive current transducer measures sinusoidal alternating currents within the range from 0 to 1 A/0 to 5 A.

- Loop-powered
- Measuring ranges 1 and 5 A AC reconnectable



For sinusoidal alternating currents
0 ... 1 A/0 ... 5 A

Housing width 22.5 mm

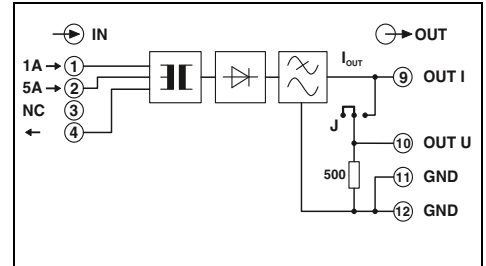

Technical data

Input data	1 A input	5 A input
Input current	0 A AC ... 1 A	0 A AC ... 5 A
Frequency range	45 Hz ... 60 Hz	45 Hz ... 60 Hz
Curve type	Sine	Sine
Overload capacity	2 x I _N (5 min. at 60°C ambient temperature)	2 x I _N (5 min. at 60°C ambient temperature)
Surge strength	50 A (1 s)	100 A (1 s)
Permissible output range	1.2 x I _N	1.2 x I _N
Connection method	Screw connection	Screw connection
Output data	U output	I output
Output signal	0 ... 10 V	0 ... 20 mA
Maximum output signal	20 V	30 mA
Load R _B	> 100 kΩ	< 750 Ω < 250 Ω (when current and voltage outputs are used simultaneously)
Ripple	< 50 mV _{PP}	< 50 mV _{PP}
General data	Maximum transmission error < 0.5 % (of final value) Temperature coefficient < 0.015 %/K Step response (10-90%) < 200 ms Safe isolation acc. to EN 50178, EN 61010 Rated insulation voltage 300 V AC (to ground) Surge voltage category/degree of pollution III / 2 Degree of protection IP20 Ambient temperature range -25 °C ... 60 °C Dimensions W/H/D 22.5 / 99 / 114.5 mm Screw connection solid/stranded/AWG 0.2 ... 2.5 mm ² / 0.2 ... 2.5 mm ² / 24 - 14 EMC note Class A product, see page 605	
Conformance/Approvals	CE-compliant	

Ordering data

Description	Type	Order No.	Pcs./Pkt.
MCR passive current transducer for sinusoidal alternating currents	MCR-SLP-1-5-UI-0	2814359	1

AC current protector, sinusoidal

The **MCR-SL-S-16-SP-24** current protector converts sinusoidal 50 Hz/60 Hz alternating currents into binary switching signals.

- Switching point can be freely selected in the measuring range of 0 to 16 A AC
- Relay PDT output
- Adjustable switch hysteresis
- 3-way isolation
- Adjustable operating current / quiescent current behavior



For sinusoidal alternating currents,
0 ... 16 A AC



Housing width 22.5 mm

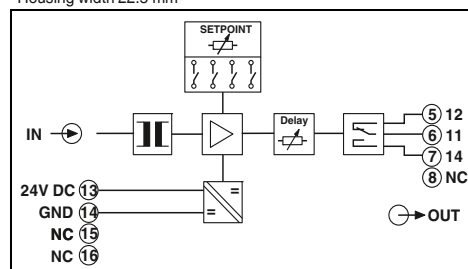

Technical data

Input data

Input current
Frequency range
Curve type
Overload capacity
Connection method

Switching output

Contact type
Contact material
Max. switching current

Switching hysteresis

Response delay

Operating and closed circuit current behavior
Relay status display

General data

Supply voltage U_B
Current consumption
Setting accuracy
Temperature coefficient
Step response (10-90%)
Safe isolation
Rated insulation voltage
Surge voltage category/degree of pollution
Test voltage input/output
Test voltage input/power supply
Degree of protection
Ambient temperature range
Dimensions W/H/D
Screw connection solid/stranded/AWG
EMC note

Conformance/Approvals

Conformance

0 A AC ... 16 A

45 Hz ... 65 Hz

Sine

$2 \times I_N$ (continuous)

Through connection, diameter 4.2 mm

Relay output

1 PDT

AgSnO, hard gold-plated

50 mA (for gold layer, 30 V AC/ 36 V DC)

2 A (in case of a destroyed gold layer, 250 V AC)

Adjustable using a DIP switch (0.5 %, 5 %, 10 %, 15 %)

typ. 0.1 s ... 10 s (Adjustable using a potentiometer)

Adjustable using a DIP switch

Yellow LED (relay active)

20 V DC ... 30 V DC

< 30 mA

< 0.5 %

< 0.02 %/K

40 ms

acc. to EN 50178, EN 61010-1

300 V AC (to ground)

III / 2

4 kV (50 Hz, 1 min.)

4 kV (50 Hz, 1 min.)

IP20

-20 °C ... 65 °C

22.5 / 99 / 114.5 mm

0.2 ... 2.5 mm² / 0.2 ... 2.5 mm² / 24 - 14

Class A product, see page 605

CE-compliant

Ordering data

Description

MCR current protector for sinusoidal alternating currents

Type

MCR-SL-S- 16-SP- 24

Order No.

2864464

Pcs./Pkt.

1

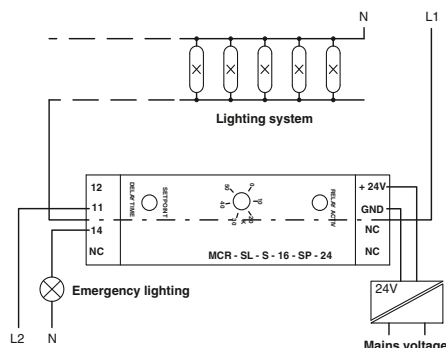

Lighting system with emergency lighting

Monitoring

Current measurement

Voltage transducers

The MACX MCR-VDC voltage transducer measures DC voltages within the range of 0 to ± 660 V DC. The MACX MCR-VAC module measures sinusoidal AC voltages from 0 to 660 V AC.

- Bidirectional output signals
- 9 voltage measuring ranges
- Voltage measuring ranges can be freely adjusted
- ZERO/SPAN adjustment $\pm 20\%$
- 3-way isolation



new

For DC voltages from 0 to ± 660 V DC



new

For sinusoidal AC voltages 0 ... 660 V AC



Housing width 22.5 mm

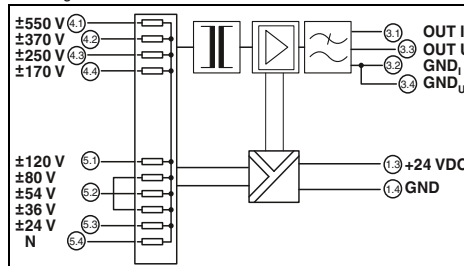

Technical data

±550 V DC ... 550 V DC	5500 k Ω
±370 V DC ... 370 V DC	3700 k Ω
±250 V DC ... 250 V DC	2500 k Ω
±170 V DC ... 170 V DC	1700 k Ω
±120 V DC ... 120 V DC	1200 k Ω
±80 V DC ... 80 V DC	800 k Ω
±54 V DC ... 54 V DC	540 k Ω
±36 V DC ... 36 V DC	540 k Ω
±24 V DC ... 24 V DC	540 k Ω
$\pm 20\% / \pm 20\%$	
-	
± 660 V DC	
U output	I output
-10 ... 10 V	-20 ... 20 mA
≤ 11 V	≤ 22 mA
> 10 k Ω	$< 500 \Omega$
50 mV	50 mV



Housing width 22.5 mm

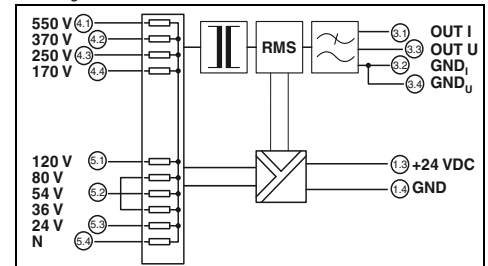

Technical data

0 V ... 550 V AC	5500 k Ω
0 V ... 370 V AC	3700 k Ω
0 V ... 250 V AC	2500 k Ω
0 V ... 170 V AC	1700 k Ω
0 V ... 120 V AC	1200 k Ω
0 V ... 80 V AC	800 k Ω
0 V ... 54 V AC	800 k Ω
0 V ... 36 V AC	800 k Ω
0 V ... 24 V AC	240 k Ω
$\pm 20\% / \pm 20\%$	
45 Hz ... 405 Hz	
+ 660 V AC	
U output	I output
0 ... 10 V / 2 ... 10 V	0 ... 20 mA / 4 ... 20 mA
≤ 11 V	≤ 22 mA
> 10 k Ω	$< 500 \Omega$
50 mV	50 mV

Input data	
Input voltage range / resistor	
ZERO / SPAN adjustment	
Frequency range	
Maximum input voltage	
Output data	
Output signal	
Maximum output signal	
Load R_B	
Ripple	
General data	
Supply voltage U_B	19.2 V DC ... 30 V DC
Current consumption	< 60 mA
Maximum transmission error	$< 1\%$ (of measuring range end value)
Temperature coefficient	$< 0.015\%$ /K
Step response (10-90%)	< 16 ms
Safe isolation	according to IEC 61010-1
Rated insulation voltage	300 V DC
Surge voltage category/degree of pollution	- / 2
Degree of protection	IP20
Dimensions W/H/D	22.5 / 99 / 114.5 mm
Connection data solid/stranded/AWG	0.2 ... 2.5 mm ² / 0.2 ... 2.5 mm ² / 24 - 14
EMC note	Class A product, see page 605
Conformance/Approvals	
Conformance	CE-compliant
UL, USA/Canada	UL 61010 Listed

Ordering data

Description	Type	Order No.	Pcs./ Pkt.
MCR voltage transducer , for DC voltages from 0 ... ± 20 V DC to 0 ... ± 660 V DC			
- with screw connection			
- with Push-in connection			
MCR voltage transducer , for sinusoidal AC voltages from 0 ... 20 V AC to 0 ... 660 V AC			
- with screw connection			
- with Push-in connection			
	MACX MCR-VDC	2906242	1
	MACX MCR-VDC-PT	2906243	1

Ordering data

Description	Type	Order No.	Pcs./ Pkt.
	MACX MCR-VAC	2906239	1
	MACX MCR-VAC-PT	2906244	1

Accessories

Configuration software package

The **MCR/PI-CONF-WIN** configuration software package is used to configure and visualize all parameters for the programmable MCR measuring transducers.

- Straightforward menu interface
- Rapid programming

Notes:

The software runs under the following operating systems: Windows NT™, 2000™, and XP™.



For MCR-S-... current transducer

Description
MCR configuration software , for programming MCR-T-..., MCR-...-LP-..., MCR-...-HT-..., MCR-S-..., MCR-F-..., and MCR-PSP-... modules, CD-ROM
Labels , for marking MCR-T and MCR-S modules, four sheets DIN A4 marking labels (112 pcs.)

Ordering data		
Type	Order No.	Pcs./Pkt.
MCR/PI-CONF-WIN	2814799	1
Accessories		
MCR-ET 38X35 WH	2814317	1

USB adapter cable

Software adapter cable

The following adapter cables are available for programming the MCR-S... current transducers:

- USB adapter cable
- Software adapter cable



For MCR-S-... current transducer

Description
USB adapter cable , D-9-SUB to USB, with adapter D-9-SUB to D-25-SUB
Software adapter cable (stereo jack plug/25-pos. D-SUB), 1.2 m long, for programming MCR-T-..., MCR-S-..., and MCR-F-... modules
Adapter cable , flexible, 9-pos. D-SUB socket to 25-pos. D-SUB pin

Ordering data		
Type	Order No.	Pcs./Pkt.
CM-KBL-RS232/USB	2881078	1
MCR-TTL-RS232-E	2814388	1
Accessories		
PSM-KAD 9 SUB 25/BS	2761295	1

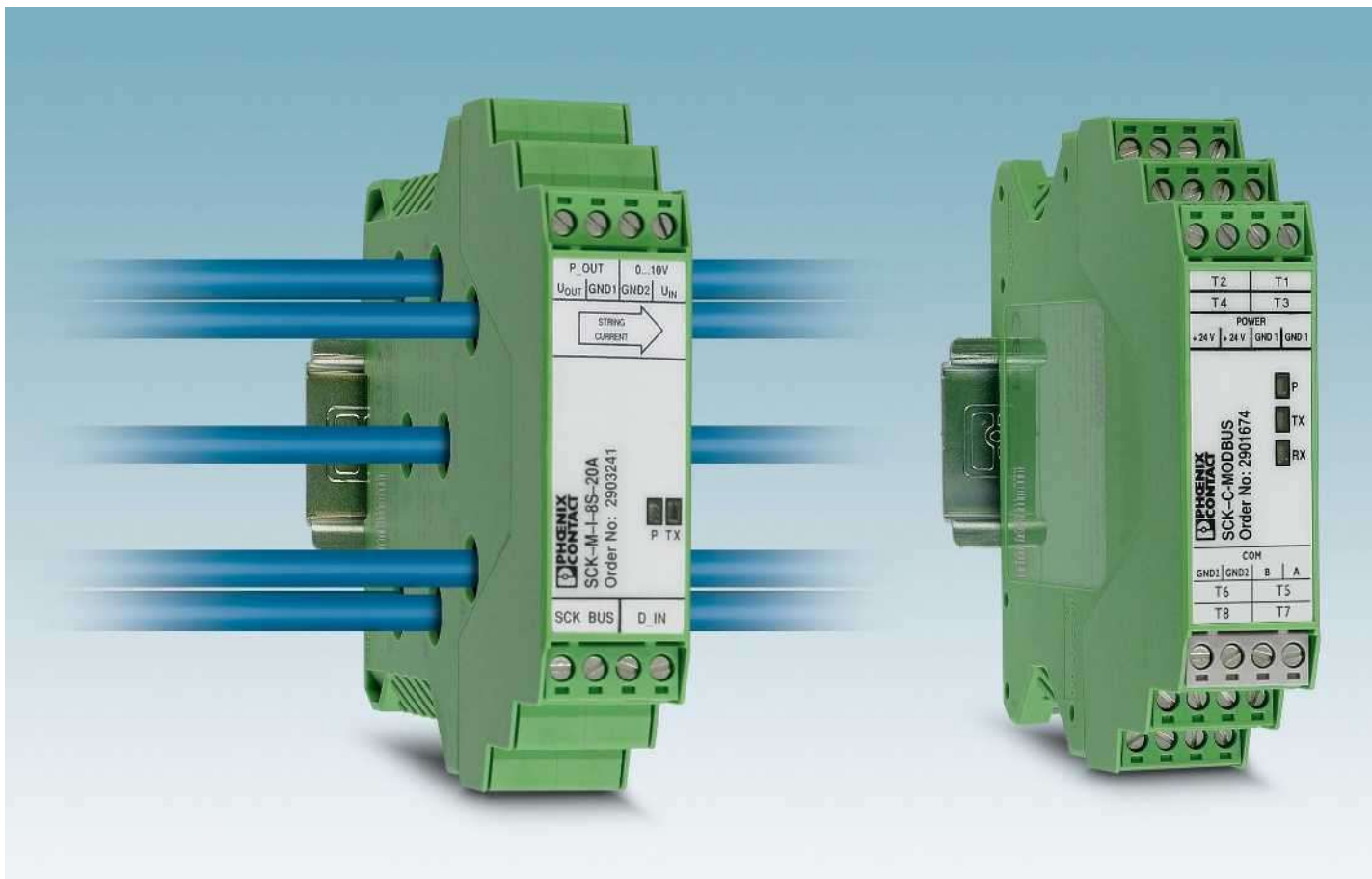

Utilize solar electricity efficiently

Detect errors – increase efficiency: photovoltaic systems should achieve maximum energy yield within the shortest possible time.

SOLARCHECK provides reliable information regarding the performance of your photovoltaic system. It can be used to detect faults, which may be caused by damaged panels, defective contacts or damage in the cabling. This allows you to implement countermeasures quickly, thereby increasing the efficiency of your system.

Current topic: reliable monitoring

Whether a small roof-top system on a family home or a megawatt outdoor system: for reliable operation, the photovoltaic market requires monitoring systems where status information is continuously available and visualization is easy. Phoenix Contact offers a comprehensive portfolio of hardware and software products specifically designed for this purpose.

Energy of the future

From installation to monitoring. In the “Components and systems for photovoltaics” brochure you will find further innovative solutions for your photovoltaic system, such as:

- Connection technology
- Surge protection
- Hardware and software solutions
- Generator connection boxes
- Tools and marking

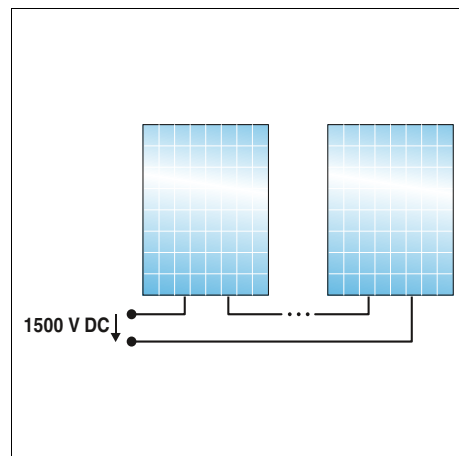
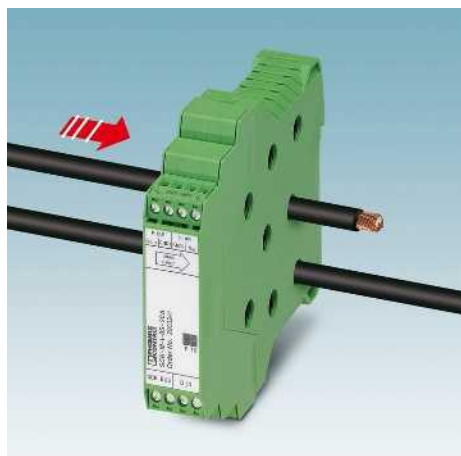

Contact-free current measurement

Contact-free measurement using Hall sensors offers many advantages:

- Safe isolation is already ensured by the cable insulation.
- No contact resistance due to additional contact points.
- Reliable current transfer, as there is no direct intervention in the string circuit.

Space-saving installation without an additional power supply

With a width of just 22.5 mm, the narrow measuring module bundles the cables in a confined space.

- The 2-conductor communication cable is also used to supply the measuring modules.
- This means that one communication module supplies up to eight measuring modules – without an additional power supply.

Flexible expansion

Optional extension of voltage measurement up to 1500 V DC

- Also suitable for grounded systems.
- Suitable for PV systems with extra high system voltages
- Flexible use, even outside the SOLARCHECK system

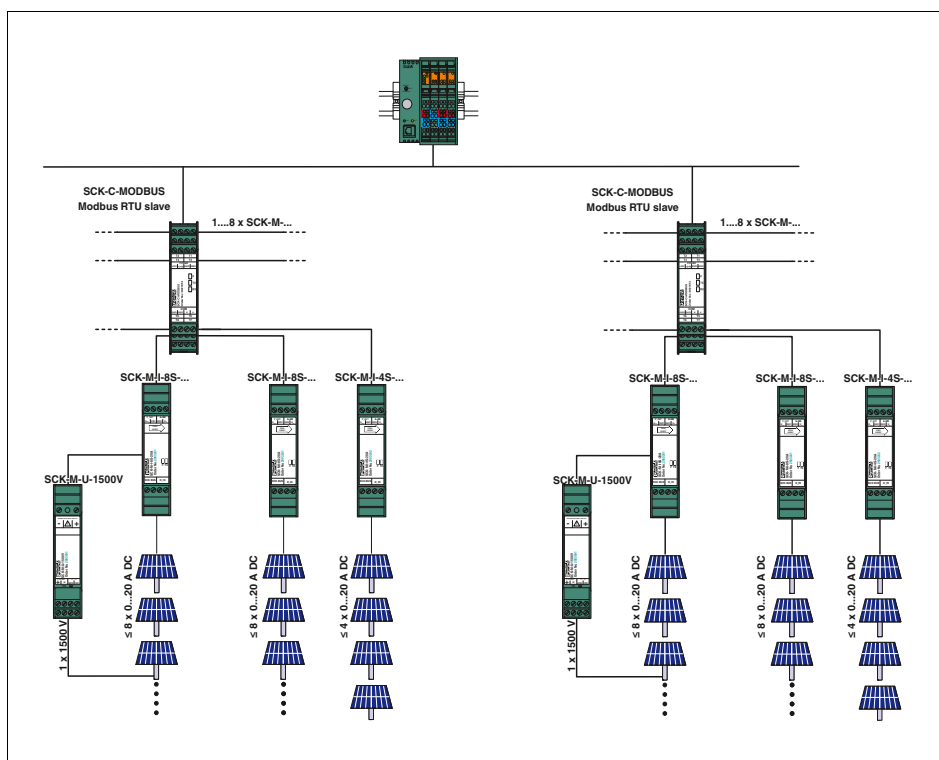

Easy integration in monitoring systems

The modular SOLARCHECK monitoring system consists of various measuring modules for current and voltage measurement and an associated communication module.

The communication module collects the measured values from the current measuring modules and forwards them to a higher-level controller. You can acquire up to eight or four string currents with one current measuring module each. A maximum of eight current measuring modules of any type can be connected to one communication module. The 2-conductor communication cable is also used to supply the measuring modules with power. This means that no additional power supply is required in the field.

The voltage measuring module is connected to and also supplied via the analog input provided on the 8-channel current measuring modules.

Monitoring

Monitoring and diagnostics

Solar system monitoring

PV string monitoring

SOLARCHECK

The modular SOLARCHECK monitoring system consists of various devices for current and voltage measurement and an associated communication module.

Communication module:

- For connecting and collecting measured values from up to eight measuring modules
- Provision of data for transfer to higher-level controllers

Current measuring modules:

- 8-channel current measurement up to 20 A DC
- Detection of reverse currents up to -1 A
- 4-channel extension modules for 20 A DC
- Internal temperature monitoring
- Digital input for monitoring, e.g., the remote indication contacts of surge protection modules
- Supply via the communication module

Voltage measuring module

- Voltage measurement up to 1500 V DC in any grounded PV system
- Connection and supply is usually via the analog input (0 to 10 V) provided on the 8-channel SOLARCHECK current measuring module
- Voltage measurement is output as an analog signal 2 to 10 V
- As an option, can also be removed from the SOLARCHECK group and used separately



Communication module
RS-485 (Modbus RTU)



Housing width 22.5 mm

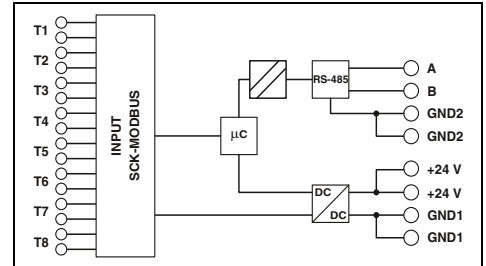

Technical data

Supply	
Supply voltage	24 V DC -10 % ... +25 %
Own current consumption	22 mA (typical)
Measuring input	
Current measuring range	-
Transmission error, maximum	-
Temperature coefficient	-
Reverse current detection	-
Number of measuring channels	-
Voltage measuring range	-
Connection method	-
Digital input	
Controlled by external floating contact	-
Analog input	
Input voltage range	-
Analog output	
Output voltage range	-
SCK-C-MODBUS data interface	
Cable length (for 0.15 mm ²)	-
Communication protocol	Proprietary
Serial port	RS-485
Serial transmission speed	9.6/14.4/19.2/38.4 kbps
Cable length	≤ 1200 m
Communication protocol	Modbus/RTU
General data	
Degree of protection	IP20
Ambient temperature range	-20 °C ... 70 °C
Dimensions W/H/D	22.5 / 102 / 106 mm
Screw connection solid/stranded/AWG	0.2 ... 2.5 mm ² / 0.2 ... 2.5 mm ² / 24 - 12
EMC note	Class A product, see page 605
Conformance/Approvals	
Conformance	CE-compliant
UL, USA	1741 Recognized
UL, USA/Canada	508 Listed

Ordering data

Description	Type	Order No.	Pcs./Pkt.
Communication module			
Current measuring module, 8-channel	SCK-C-MODBUS	2901674	1
Current measuring module, 4-channel for extension			
Voltage measuring module			



Current measuring module, 20 A DC, 8-channel



Extension module, 4-channel Current measurement 20 A DC



Voltage measuring module, 0...1500 V DC

Housing width 22.5 mm

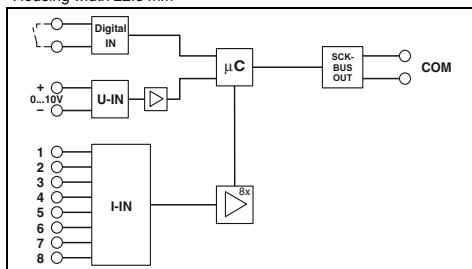

Technical data

Via SCK-C-MODBUS
 43 mA (typical)
 0 A DC ... 20 A (UL: 0 A DC...25 A DC)
 ± 1 % (From the measuring range final value)
 0.02 %/K (T_{K20})
 -1 A DC ... 0 mA
 8
 Through connection, 9.5 mm diameter

Housing width 22.5 mm

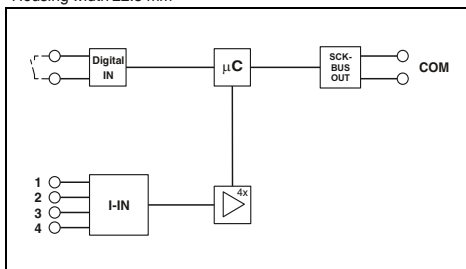

Technical data

Via SCK-C-MODBUS
 43 mA (typical)
 0 A DC ... 20 A (UL: 0 A DC...25 A DC)
 ± 1 % (From the measuring range final value)
 0.02 %/K (T_{K20})
 -1 A DC ... 0 mA
 4
 Through connection, 9.5 mm diameter

Housing width 22.5 mm

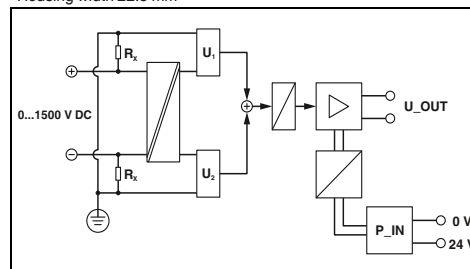

Technical data

24 V DC -10 % ... +25 % (or via SSK-M-I-8S-20A)
 8 mA (typical)
 -
 ± 1 % (after additional tuning (valid for 100 - 1500 V DC))
 < 0.01 %/K
 1
 0 V DC ... 1500 V DC
 Screw connection

Floating switch contacts

0 V ... 10 V

≤ 300 m (0.14 mm²)
 Proprietary

IP20
 -20 °C ... 70 °C
 22.5 / 102 / 128.5 mm
 0.2 ... 2.5 mm² / 0.2 ... 2.5 mm² / 24 - 12
 Class A product, see page 605

CE-compliant
 1741 Recognized
 508 Listed

Ordering data

Type	Order No.	Pcs./ Pkt.
SCK-M-I-8S-20A	2903241	1

Floating switch contacts

≤ 300 m (0.14 mm²)
 Proprietary

IP20
 -20 °C ... 70 °C
 22.5 / 102 / 128.5 mm
 0.2 ... 2.5 mm² / 0.2 ... 2.5 mm² / 24 - 12
 Class A product, see page 605

CE-compliant
 1741 Recognized
 508 Listed

Ordering data

Type	Order No.	Pcs./ Pkt.
SCK-M-I-4S-20A	2903242	1

-

2 V DC ... 10 V DC

IP20
 -20 °C ... 70 °C
 22.5 / 102 / 128.5 mm
 0.2 ... 2.5 mm² / 0.2 ... 2.5 mm² / 24 - 12
 Class A product, see page 605

CE-compliant
 1741 Recognized
 508 Listed

Ordering data

Type	Order No.	Pcs./ Pkt.
SCK-M-U-1500V	2903591	1



For high system availability

EMD monitoring relays can be used to detect deviations in important system parameters at an early stage. These can be indicated or system parts can be shut down selectively. EMD monitoring relays ensure error-free and cost-effective operation of your system. They are an inexpensive solution for numerous monitoring functions.

- Surge voltage and undervoltage
- Overcurrent and undercurrent
- Phase failure, phase sequence, and phase asymmetry
- Power factor and real power
- Motor winding temperature
- Levels

For system monitoring, choose from two product ranges: compact or multifunctional monitoring relays.

Perfect timing

ETD time relays ensure optimum time sequences.

The modules are the cost-effective alternative to a PLC: with easy configuration and fast wiring.

Choose from two product ranges for your ideal time control application:

- Ultra-narrow time relays each with one time range and one function
- Multifunctional time relays with selectable time ranges and functions

Professionally packaged components

Function modules with professional housing and connection technology can be used to integrate electronic components in your system. They can be used to perform a variety of tasks:

- Diode modules provide protection against polarity reversal. In addition, they decouple messages in fault reporting systems.
- Lamp testing modules decouple signals in isolation in the field of fault reporting technology.
- Display modules simplify troubleshooting and provide help for monitoring processes.



Compact monitoring relays

Ideal for simple monitoring tasks – from series production to building installation.

- Compact installation housing
- Quick and tool-free wiring with Push-in technology
- Parameters can be adjusted easily using rotary switches
- Clear diagnostics, thanks to color status LED



Multifunctional monitoring relays

- Parameters can be adjusted easily using rotary switches
- Fast error detection, thanks to fine tuning and short response times
- Worldwide use, thanks to wide-range power supply unit or plug-in transformer
- Space saving, with two PDT outputs in 22.5 mm wide housing
- Electrically isolated measuring and supply circuits
- Clear diagnostics, thanks to color status LEDs



Ultra-narrow time relays

The space-saving and inexpensive solution for simple time control applications.

- Each with one time range and one function
- Overall width of just 6.2 mm - saves up to 70% space compared to conventional time relays
- Precise time setting using the illuminated thumbwheel
- Fast wiring through the use of plug-in bridges



Multifunctional time relays

For universal use thanks to wide range of functions.

- Just three versions for all conventional time control applications
- Two floating PDT outputs on an overall width of just 22.5 mm
- Supply voltage via wide-range power supply unit
- Optimum setting of times ranging from milliseconds to several days



Function modules

Function modules transform components such as diodes into a shock-proof and dust-proof electronics module.

- Easy installation, thanks to electronics housing with IP20 protection that can be installed in a control cabinet
- Fast mounting on DIN rails, thanks to the foot catch
- User-friendly wiring, thanks to practical connection technology

Monitoring

Monitoring and diagnostics

Monitoring relays

Single-phase current monitoring

- The **EMD-BL-C-10** monitors AC currents from 0 to 10 A.
- Adjustable response delay
 - 0 to 5 A or 0 to 10 A measuring range
 - Adjustable via rotary switch on the front

Single-phase voltage monitoring

- The **EMD-BL-V-230** monitors DC and AC voltages.
- 24 V AC/DC or 230 V AC
 - Separately adjustable response delay
 - Adjustable monitoring range
 - Adjustable via potentiometer on front



Current monitoring, 1-phase
Overcurrent, undercurrent, window



Voltage monitoring, 1-phase
Undervoltage, window

Housing width 17.5 mm

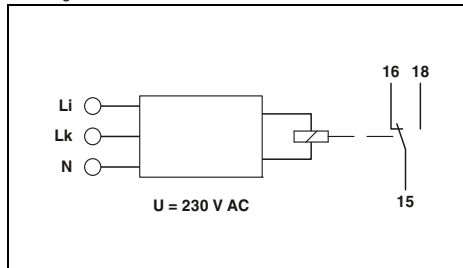

Technical data

Functions

Overcurrent, undercurrent, window

Input

Input ranges

Input ranges

0 A ... 5 A
0 A ... 10 A
Configurable via rotary switches
3 mΩ
5 % ... 95 % (From I_N)
10 % ... 100 % (From I_N)
0.1 s ... 10 s
≤ 5 % (of the nominal value)
± 5 % (of the nominal value)
≤ 2 %

Input resistance

Minimum setting range

Maximum setting range

Setting range for response delay

Basic accuracy

Setting accuracy

Repeat accuracy

Relay output

Contact type

Switching capacity

Electrical service life

Mechanical service life

Output fuse

General data

Supply voltage

Nominal power consumption

1 floating PDT
1250 VA (5 A/250 V AC)
1 x 10⁶ cycles
15 x 10⁶ cycles
5 A (fast-blow)

230 V AC ±15 %

5 VA (0.8 W)

Degree of protection

Ambient temperature (operation)

Dimensions W/H/D

Push-in connection solid/stranded/AWG

Screw connection solid/stranded/AWG

Conformance/Approvals

Conformance

UL, USA/Canada

IP40 (housing) / IP20 (connection terminal blocks)

-25 °C ... 55 °C

17.5 / 88 / 65.5 mm

0.14 ... 2.5 mm² / 0.14 ... 2.5 mm² / 26 - 14

0.5 ... 2.5 mm² / 0.5 ... 2.5 mm² / 20 - 14

CE-compliant

UL/C-UL listed UL 508

Ordering data

Description

Compact monitoring relay with Push-in connection

Compact monitoring relay with screw connection

Type

Order No.

Pcs./
Pkt.

EMD-BL-C-10-PT

2903522

1

EMD-BL-C-10

2903521

1

Housing width 17.5 mm

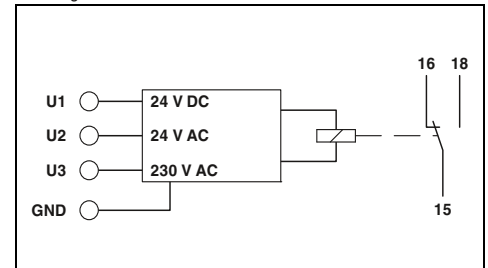

Technical data

Undervoltage, window

0 V DC ... 24 V DC (connection terminal blocks: U1 and GND)
0 V AC ... 24 V AC (connection terminal blocks: U2 and GND)
0 V AC ... 230 V AC (connection terminal blocks: U3 and GND)

75 % ... 115 % (From U_N)

80 % ... 120 % (From U_N)

0.1 s ... 10 s

≤ 5 % (of scale end value)

± 5 % (of scale end value)

≤ 2 %

1 floating PDT

1250 VA (5 A/250 V AC)

1 x 10⁶ cycles

15 x 10⁶ cycles

5 A (fast-blow)

-25 % ... +20 % (= measuring voltage)

10 VA (At 230 V AC (0.6 W))

1.3 VA (At 24 V AC (0.8 W))

0.6 W (at 24 V DC)

IP40 (housing) / IP20 (connection terminal blocks)

-25 °C ... 55 °C

17.5 / 88 / 65.5 mm

0.14 ... 2.5 mm² / 0.14 ... 2.5 mm² / 26 - 14

0.5 ... 2.5 mm² / 0.5 ... 2.5 mm² / 20 - 14

CE-compliant

UL/C-UL listed UL 508

Ordering data

Type

Order No.

Pcs./
Pkt.

EMD-BL-V-230-PT

2903524

1

EMD-BL-V-230

2903523

1

Monitoring relays

Three-phase voltage monitoring

- The **EMD-BL-3V-400** monitors three-phase AC voltages.
- 3~ 400 V AC/230 V AC ±30%
- Separately adjustable response delay
- Adjustable monitoring range
- Adjustable via potentiometer on front
- Supply from the measuring circuit

Phase monitoring

- The **EMD-BL-PH-400** monitors three-phase AC voltages.
- 3~ 208 to 480 V AC / 120 to 277 V AC
- Adjustable response delay
- Adjustable asymmetry: 5 to 25% / OFF
- Adjustable via potentiometer on front
- Supply from the measuring circuit

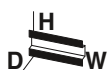

Voltage monitoring, 3-phase
Window, phase sequence



Phase monitoring
Phase sequence, phase failure, asymmetry

ERIC
Housing width 17.5 mm

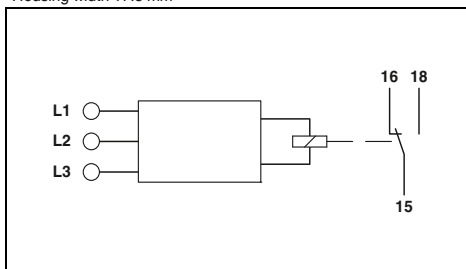

ERIC
Housing width 17.5 mm

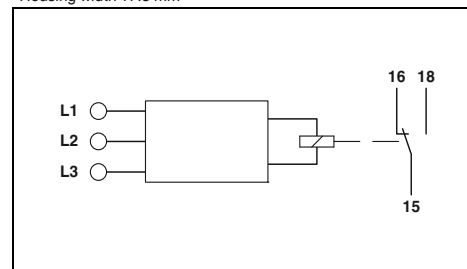

Technical data

Window, phase sequence

280 V AC ... 519 V AC
3~ 400/230 V
70 % ... 120 % (From U_N)
80 % ... 130 % (From U_N)
0.1 s ... 10 s
-
≤ 5 % (of the nominal value)
± 5 % (of scale end value)
± 2 %

1 floating PDT
1250 VA (5 A/250 V AC)
1 x 10⁵ cycles
15 x 10⁶ cycles
5 A (fast-blow)

±30 % (= measuring voltage)
10 VA (1 W)

IP40 (housing) / IP20 (connection terminal blocks)
-25 °C ... 55 °C
17.5 / 88 / 65.5 mm
0.14 ... 2.5 mm² / 0.14 ... 2.5 mm² / 26 - 14
0.5 ... 2.5 mm² / 0.5 ... 2.5 mm² / 20 - 14

CE-compliant
UL/C-UL listed UL 508

Technical data

Phase sequence, phase failure, asymmetry

187 V AC ... 519 V AC
3~ 208 ... 480 V/120 ... 277 V
-
-
0.1 s ... 10 s
5 % ... 25% / OFF
≤ 5 % (of scale end value)
± 5 % (of scale end value)
≤ 2 %

1 floating PDT
1250 VA (5 A/250 V AC)
1 x 10⁵ cycles
15 x 10⁶ cycles
5 A (fast-blow)

±10 % (= measuring voltage)
10 VA ((1 W) at 400 V/50 Hz)
16 VA ((1.5 W) at 480 V/60 Hz)

IP40 (housing) / IP20 (connection terminal blocks)
-25 °C ... 55 °C
17.5 / 88 / 65.5 mm
0.14 ... 2.5 mm² / 0.14 ... 2.5 mm² / 26 - 14
0.5 ... 2.5 mm² / 0.5 ... 2.5 mm² / 20 - 14

CE-compliant
UL/C-UL listed UL 508

Ordering data

Type	Order No.	Pcs./ Pkt.
EMD-BL-3V-400-PT	2903526	1
EMD-BL-3V-400	2903525	1

Ordering data

Type	Order No.	Pcs./ Pkt.
EMD-BL-PH-480-PT	2903528	1
EMD-BL-PH-480	2903527	1

Functions	
Input	
Monitoring range	280 V AC ... 519 V AC
Input ranges	3~ 400/230 V
Minimum setting range	70 % ... 120 % (From U_N)
Maximum setting range	80 % ... 130 % (From U_N)
Setting range for response delay	0.1 s ... 10 s
Asymmetry	-
Basic accuracy	≤ 5 % (of the nominal value)
Setting accuracy	± 5 % (of scale end value)
Repeat accuracy	± 2 %
Relay output	
Contact type	1 floating PDT
Switching capacity	1250 VA (5 A/250 V AC)
Electrical service life	1 x 10 ⁵ cycles
Mechanical service life	15 x 10 ⁶ cycles
Output fuse	5 A (fast-blow)
General data	
Supply voltage	±30 % (= measuring voltage)
Nominal power consumption	10 VA (1 W)
Degree of protection	
Ambient temperature (operation)	-25 °C ... 55 °C
Dimensions W/H/D	17.5 / 88 / 65.5 mm
Push-in connection solid/stranded/AWG	0.14 ... 2.5 mm ² / 0.14 ... 2.5 mm ² / 26 - 14
Screw connection solid/stranded/AWG	0.5 ... 2.5 mm ² / 0.5 ... 2.5 mm ² / 20 - 14
Conformance/Approvals	
Conformance	CE-compliant
UL, USA/Canada	UL/C-UL listed UL 508

Description	Type	Order No.	Pcs./ Pkt.
Compact monitoring relay with Push-in connection	EMD-BL-3V-400-PT	2903526	1
Compact monitoring relay with screw connection	EMD-BL-3V-400	2903525	1

Monitoring

Monitoring and diagnostics

Monitoring relays

Thermistor monitoring

The EMD-SL-PTC monitors the temperature of motor windings.

- Operate value $\geq 3.6 \text{ k}\Omega$
- Release value $\leq 1.6 \text{ k}\Omega$
- DIN 44081/DIN 44082-compliant
- Sensors can be connected in series



new

Temperature monitoring (motor windings)

ERC

Housing width 17.5 mm

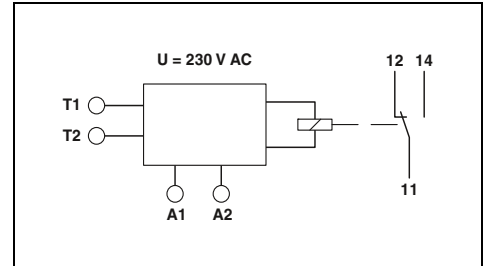

Functions	
Input	
Total cold resistance	
Response value	
Release value	
Basic accuracy	
Relay output	
Contact type	
Switching capacity	
Electrical service life	
Mechanical service life	
Output fuse	
General data	
Supply voltage	
Nominal power consumption	
Degree of protection	
Ambient temperature (operation)	
Dimensions W/H/D	
Push-in connection solid/stranded/AWG	
Screw connection solid/stranded/AWG	
Conformance/Approvals	
Conformance	

Technical data

Winding temperature monitoring	
	$\leq 1.5 \text{ k}\Omega$
	$\geq 3.6 \text{ k}\Omega$ (Relay drops out)
	$\leq 1.6 \text{ k}\Omega$ (Relay picks up)
	$\pm 10 \%$ (of scale end value)
Relay output	
Contact type	1 floating PDT
Switching capacity	1250 VA (5 A/250 V AC)
Electrical service life	1×10^5 cycles
Mechanical service life	15×10^6 cycles
Output fuse	5 A (fast-blow)
General data	
Supply voltage	230 V AC (-15 % ... +10 %)
Nominal power consumption	3.5 VA (0.5 W)
Degree of protection	IP40 (housing) / IP20 (connection terminal blocks)
Ambient temperature (operation)	-25 °C ... 55 °C
Dimensions W/H/D	17.5 / 88 / 65.5 mm
Push-in connection solid/stranded/AWG	0.14 ... 2.5 mm ² / 0.14 ... 2.5 mm ² / 26 - 14
Screw connection solid/stranded/AWG	0.5 ... 2.5 mm ² / 0.5 ... 2.5 mm ² / 20 - 14
Conformance/Approvals	
Conformance	

Ordering data

Description	
Compact monitoring relay	
with Push-in connection	
with screw connection	

Type	Order No.	Pcs./Pkt.
EMD-BL-PTC-PT	2906253	1
EMD-BL-PTC	2906252	1

Monitoring

Monitoring and diagnostics

Monitoring relays

Single-phase current monitoring

EMD-...C... monitoring relays monitor DC and AC currents within the range of 0 to 10 A.

- Separately adjustable startup and release delays
- Variable supply voltage range
- Adjustable via potentiometer on front



Overcurrent and undercurrent monitoring



Over or undercurrent monitoring

Housing width 22.5 mm

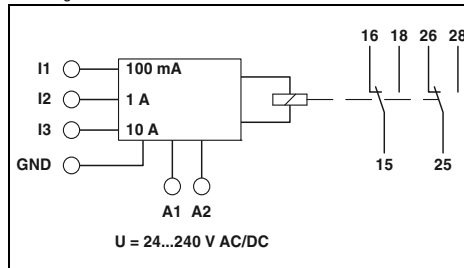

Technical data

Functions	Overcurrent, undercurrent, window, error memory
Input	0 mA ... 100 mA (Connection terminals: I1 and GND) 0 A ... 1 A (Connection terminals: I2 and GND) 0 A ... 10 A (Connection terminals: I3 and GND)
Input ranges	470 mΩ (at I _N = 100 mA) ; 47 mΩ (at I _N = 1 A) ; 5 mΩ (at I _N = 10 A)
Input resistance	470 mΩ (at I _N = 100 mA) ; 47 mΩ (at I _N = 1 A) ; 5 mΩ (at I _N = 10 A)
Minimum setting range	5 % ... 95 % (From I _N)
Maximum setting range	10 % ... 100 % (From I _N)
Setting range for response delay	0.1 s ... 10 s
Setting range for starting delay	0 s ... 10 s
Basic accuracy	± 5 % (of scale end value)
Setting accuracy	≤ 5 % (of scale end value)
Repeat accuracy	≤ 2 %
Relay output	2 floating PDT contacts
Contact type	750 VA (3 A/250 V AC, module aligned, ≤ 5 mm spacing) 1250 VA (5 A/250 V AC, module not aligned, ≥ 5 mm spacing)
Switching capacity	750 VA (3 A/250 V AC, module aligned, ≤ 5 mm spacing) 1250 VA (5 A/250 V AC, module not aligned, ≥ 5 mm spacing)
Electrical service life	2 x 10 ⁵ cycles at ohmic load, 1000 VA
Mechanical service life	Approx. 2x 10 ⁷ cycles
Output fuse	5 A (fast-blow)
General data	24 V AC ... 240 V AC -15 % ... +10 % 24 V DC ... 240 V DC -20 % ... +25 % 4.5 VA (1.5 W) IP40 (housing) / IP20 (connection terminal blocks) -25 °C ... 55 °C 22.5 / 90 / 113 mm 0.5 ... 2.5 mm ² / 0.25 ... 2.5 mm ² / 20 - 14 Class A product, see page 605
Supply voltage range	24 V AC ... 240 V AC -15 % ... +10 % 24 V DC ... 240 V DC -20 % ... +25 % 4.5 VA (1.5 W)
Nominal power consumption	IP40 (housing) / IP20 (connection terminal blocks)
Degree of protection	-25 °C ... 55 °C
Ambient temperature (operation)	22.5 / 90 / 113 mm
Dimensions W/H/D	0.5 ... 2.5 mm ² / 0.25 ... 2.5 mm ² / 20 - 14
EMC note	Class A product, see page 605
Conformance/Approvals	CE-compliant UL/C-UL listed UL 508

Housing width 22.5 mm

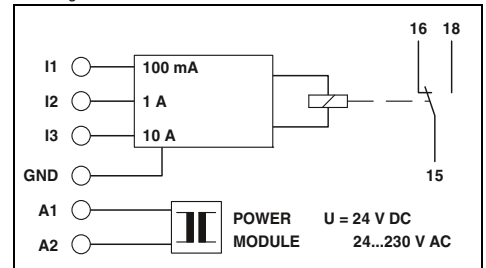

Technical data

EMD-SL-C-OC-10	EMD-SL-C-UC-10
Overcurrent	Undercurrent
0 mA ... 100 mA (Connection terminals: I1 and GND) 0 A ... 1 A (Connection terminals: I2 and GND) 0 A ... 10 A (Connection terminals: I3 and GND)	0 mA ... 100 mA (Connection terminals: I1 and GND) 0 A ... 1 A (Connection terminals: I2 and GND) 0 A ... 10 A (Connection terminals: I3 and GND)
470 mΩ (at I _N = 100 mA) ; 47 mΩ (at I _N = 1 A) ; 5 mΩ (at I _N = 10 A)	470 mΩ (at I _N = 100 mA) ; 47 mΩ (at I _N = 1 A) ; 5 mΩ (at I _N = 10 A)
5 % ... 95 % (From I _N)	5 % ... 95 % (From I _N)
10 % ... 100 % (From I _N)	10 % ... 100 % (From I _N)
0.2 s ... 10 s	0.2 s ... 10 s
-	-
± 5 % (of scale end value)	± 5 % (of scale end value)
≤ 5 % (of scale end value)	≤ 5 % (of scale end value)
≤ 2 %	≤ 2 %
1 floating PDT	1 floating PDT
750 VA (3 A/250 V AC, module aligned, ≤ 5 mm spacing) 1250 VA (5 A/250 V AC, module not aligned, ≥ 5 mm spacing)	750 VA (3 A/250 V AC, module aligned, ≤ 5 mm spacing) 1250 VA (5 A/250 V AC, module not aligned, ≥ 5 mm spacing)
2 x 10 ⁵ cycles at ohmic load, 1000 VA	2 x 10 ⁵ cycles at ohmic load, 1000 VA
Approx. 2x 10 ⁷ cycles	Approx. 2x 10 ⁷ cycles
5 A (fast-blow)	5 A (fast-blow)
24 V AC ... 240 V AC -15 % ... +10 % 24 V DC ... 240 V DC -20 % ... +25 % 4.5 VA (1.5 W)	24 V AC ... 230 V AC (see Power modules) 24 V DC (see Power modules) 2 VA (1.5 W)
IP40 (housing) / IP20 (connection terminal blocks)	IP40 (housing) / IP20 (connection terminal blocks)
-25 °C ... 55 °C	-25 °C ... 55 °C
22.5 / 90 / 113 mm	22.5 / 90 / 113 mm
0.5 ... 2.5 mm ² / 0.25 ... 2.5 mm ² / 20 - 14	0.5 ... 2.5 mm ² / 0.25 ... 2.5 mm ² / 20 - 14
CE-compliant UL/C-UL listed UL 508	CE-compliant UL/C-UL listed UL 508

Ordering data

Description	Type	Order No.	Pcs./Pkt.
Electronic monitoring relay	EMD-FL-C-10	2866022	1
Power module, plug-in, please order at the same time!			
Supply voltage 20 ... 30 V DC			
Supply voltage 20.2 ... 26.4 V AC			
Supply voltage 88 ... 121 V AC			
Supply voltage 108 ... 132 V AC			
Supply voltage 195 ... 264 V AC			

Ordering data

Type	Order No.	Pcs./Pkt.
EMD-SL-C-OC-10	2866019	1
EMD-SL-C-UC-10	2867937	1
EMD-SL-PS-24DC	2885359	1
EMD-SL-PS-24AC	2866103	1
EMD-SL-PS-110AC	2866116	1
EMD-SL-PS-120AC	2885731	1
EMD-SL-PS-230AC	2866129	1

Monitoring relays

Single-phase voltage monitoring

EMD-...V... monitoring relays monitor DC and AC voltages within the range 0 to 300 V.

- Separately adjustable startup and release delays
- Variable supply voltage range
- Adjustable via potentiometer on front



Undervoltage and overvoltage monitoring



Undervoltage monitoring

FRAC Housing width 22.5 mm

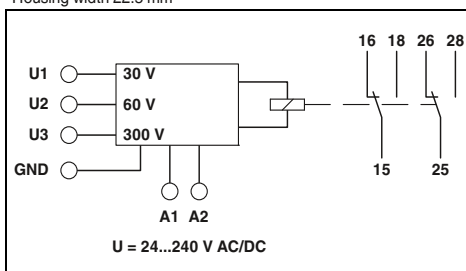

Technical data

Undervoltage, overvoltage, window, error memory

FRAC Housing width 22.5 mm

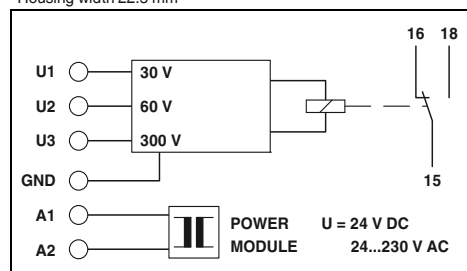

Technical data

Undervoltage

Functions

Input

Input ranges

Input resistance

Minimum setting range

Maximum setting range

Setting range for response delay

Setting range for starting delay

Basic accuracy

Setting accuracy

Repeat accuracy

Relay output

Contact type

Switching capacity

Electrical service life

Mechanical service life

Output fuse

General data

Supply voltage range

Nominal power consumption

Degree of protection

Ambient temperature (operation)

Dimensions W/H/D

Screw connection solid/stranded/AWG

EMC note

Conformance/Approvals

Conformance

UL, USA/Canada

0 V ... 30 V AC/DC (connection terminal blocks: U1 and GND)
0 V ... 60 V AC/DC (connection terminal blocks: U2 and GND)
0 V ... 300 V AC/DC (connection terminal blocks: U3 and GND)

47 kΩ (connection terminal blocks: U1 and GND)
100 kΩ (connection terminal blocks: U2 and GND)
470 kΩ (connection terminal blocks: U3 and GND)

5 % ... 95 % (From U_N)
10 % ... 100 % (From U_N)

0.1 s ... 10 s
0 s ... 10 s

± 5 % (of scale end value)
≤ 5 % (of scale end value)

≤ 2 %

2 floating PDT contacts

750 VA (3 A/250 V AC, module aligned, ≤ 5 mm spacing)
1250 VA (5 A/250 V AC, module not aligned, ≥ 5 mm spacing)

2 x 10⁵ cycles at ohmic load, 1000 VA

Approx. 2x 10⁷ cycles

5 A (fast-blow)

24 V AC ... 240 V AC -15 % ... +10 %
24 V DC ... 240 V DC -20 % ... +25 %

4.5 VA (1.5 W)

IP40 (housing) / IP20 (connection terminal blocks)

-25 °C ... 55 °C

22.5 / 90 / 113 mm

0.5 ... 2.5 mm² / 0.25 ... 2.5 mm² / 20 - 14

Class A product, see page 605

CE-compliant

UL/C-UL listed UL 508

0 V ... 30 V AC/DC (connection terminal blocks: U1 and GND)
0 V ... 60 V AC/DC (connection terminal blocks: U2 and GND)
0 V ... 300 V AC/DC (connection terminal blocks: U3 and GND)

47 kΩ (connection terminal blocks: U1 and GND)
100 kΩ (connection terminal blocks: U2 and GND)
470 kΩ (connection terminal blocks: U3 and GND)

5 % ... 95 % (From U_N)
10 % ... 100 % (From U_N)

0.2 s ... 10 s

-

± 5 % (of scale end value)
≤ 5 % (of scale end value)

≤ 2 %

1 floating PDT

750 VA (3 A/250 V AC, module aligned, ≤ 5 mm spacing)
1250 VA (5 A/250 V AC, module not aligned, ≥ 5 mm spacing)

2 x 10⁵ cycles at ohmic load, 1000 VA

Approx. 2x 10⁷ cycles

5 A (fast-blow)

24 V AC ... 230 V AC (see Power modules)
24 V DC (see Power modules)

2 VA (1.5 W)

IP40 (housing) / IP20 (connection terminal blocks)

-25 °C ... 55 °C

22.5 / 90 / 113 mm

0.5 ... 2.5 mm² / 0.25 ... 2.5 mm² / 20 - 14

CE-compliant

UL/C-UL listed UL 508

Description

Electronic monitoring relay

Power module, plug-in, please order at the same time!

Supply voltage 20 ... 30 V DC

Supply voltage 20.2 ... 26.4 V AC

Supply voltage 88 ... 121 V AC

Supply voltage 108 ... 132 V AC

Supply voltage 195 ... 264 V AC

Ordering data

Type	Order No.	Pcs./ Pkt.
EMD-FL-V-300	2866048	1

Ordering data

Type	Order No.	Pcs./ Pkt.
EMD-SL-V-UV-300	2866035	1
EMD-SL-PS- 24DC	2885359	1
EMD-SL-PS- 24AC	2866103	1
EMD-SL-PS-110AC	2866116	1
EMD-SL-PS-120AC	2885731	1
EMD-SL-PS-230AC	2866129	1

Monitoring

Monitoring and diagnostics

Monitoring relays

Three-phase voltage monitoring

EMD-...-3V... monitoring relays monitor three-phase AC voltages of 160 to 897 V AC (depending on the device concerned).

- Adjustable response delay
- Variable supply voltage range
- Adjustable via potentiometer on front
- Adjustable asymmetry



**Undervoltage and phase monitoring,
400 V or 230 V**



**Undervoltage and phase monitoring,
500 V or 690 V**

Housing width 22.5 mm

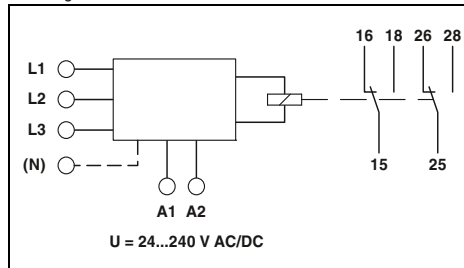

Housing width 45 mm

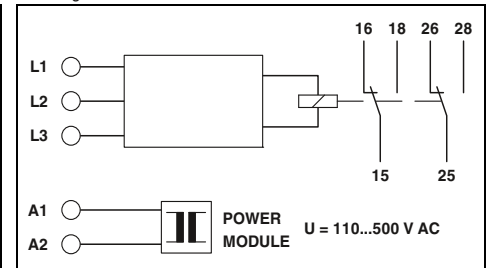

Technical data

Functions	EMD-FL-3V-400	EMD-FL-3V-230
Input		
Monitoring range	280 V AC ... 520 V AC	161 V AC ... 299 V AC
Input ranges	3 N ~ 400/230 V	3 N ~ 230/132 V
Input resistance	1 MΩ	470 kΩ
Minimum setting range	-30 % ... 20 % (From U _N)	
Maximum setting range	-20 % ... 30 % (From U _N)	
Setting range for response delay	0.1 s ... 10 s	
Asymmetry	5 % ... 25% / OFF	5 % ... 25% / OFF
Basic accuracy	± 5 % (of scale end value)	
Setting accuracy	≤ 5 % (of scale end value)	
Repeat accuracy	≤ 2 %	
Relay output		
Contact type	2 floating PDT contacts	
Switching capacity	750 VA (3 A/250 V AC, module aligned, ≤ 5 mm spacing) 1250 VA (5 A/250 V AC, module not aligned, ≥ 5 mm spacing)	
Electrical service life	2 x 10 ⁵ cycles at ohmic load, 1000 VA	
Mechanical service life	Approx. 2x 10 ⁷ cycles	
Output fuse	5 A (fast-blow)	
General data		
Supply voltage		
Supply voltage range	24 V AC ... 240 V AC -15 % ... +10 % 24 V DC ... 240 V DC -20 % ... +25 %	
Nominal power consumption	4.5 VA (1.5 W)	
Degree of protection	IP40 (housing) / IP20 (connection terminal blocks)	
Ambient temperature (operation)	-25 °C ... 55 °C	
Dimensions W/H/D	22.5 / 90 / 113 mm	
Screw connection solid/stranded/AWG	0.5 ... 2.5 mm ² / 0.25 ... 2.5 mm ² / 20 - 14	
EMC note	Class A product, see page 605	
Conformance/Approvals		
Conformance	CE-compliant	
UL, USA/Canada	UL/C-UL listed UL 508	

Technical data

Functions	EMD-FL-3V-690	EMD-FL-3V-500
Input		
Monitoring range	483 V AC ... 897 V AC	350 V AC ... 650 V AC
Input ranges	3 ~ 690 V	3 ~ 500 V
Input resistance	1 MΩ	1 MΩ
Minimum setting range	-30 % ... 20 % (From U _N)	
Maximum setting range	-20 % ... 30 % (From U _N)	
Setting range for response delay	0.1 s ... 10 s	
Asymmetry	5 % ... 25% / OFF	5 % ... 25% / OFF
Basic accuracy	± 5 % (of scale end value)	
Setting accuracy	≤ 5 % (of scale end value)	
Repeat accuracy	≤ 2 %	
Relay output		
Contact type	2 floating PDT contacts	
Switching capacity	750 VA (3 A/250 V AC, module aligned, ≤ 5 mm spacing) 1250 VA (5 A/250 V AC, module not aligned, ≥ 5 mm spacing)	
Electrical service life	2 x 10 ⁵ cycles at ohmic load, 1000 VA	
Mechanical service life	Approx. 2x 10 ⁷ cycles	
Output fuse	5 A (fast-blow)	
General data		
Supply voltage		
Supply voltage range	110 V AC ... 500 V AC (see Power modules)	
Nominal power consumption	4.5 VA (1.5 W)	
Degree of protection	IP40 (housing) / IP20 (connection terminal blocks)	
Ambient temperature (operation)	-25 °C ... 55 °C	
Dimensions W/H/D	45 / 90 / 113 mm	
Screw connection solid/stranded/AWG	0.5 ... 2.5 mm ² / 0.25 ... 2.5 mm ² / 20 - 14	
EMC note		
Conformance/Approvals		
Conformance	CE-compliant	
UL, USA/Canada	UL/C-UL listed UL 508	

Ordering data

Description	Type	Order No.	Pcs./ Pkt.
Electronic monitoring relay			
	EMD-FL-3V-400	2866064	1
	EMD-FL-3V-230	2885773	1
Power module, plug-in, please order at the same time!			
Supply voltage 20 ... 30 V DC			
Supply voltage 20.2 ... 26.4 V AC			
Supply voltage 88 ... 121 V AC			
Supply voltage 108 ... 132 V AC			
Supply voltage 195 ... 264 V AC			
Supply voltage 323 ... 456 V AC			

Ordering data

Description	Type	Order No.	Pcs./ Pkt.
Electronic monitoring relay			
	EMD-FL-3V-690	2885249	1
	EMD-FL-3V-500	2867979	1
Power module, plug-in, please order at the same time!			
Supply voltage 20 ... 30 V DC			
Supply voltage 20.2 ... 26.4 V AC			
Supply voltage 88 ... 121 V AC			
Supply voltage 108 ... 132 V AC			
Supply voltage 195 ... 264 V AC			
Supply voltage 323 ... 456 V AC			



Undervoltage/overvoltage monitoring, 400 V with/without neutral conductor



Phase monitoring, 400 V



Phase monitoring, 690 V



Housing width 22.5 mm

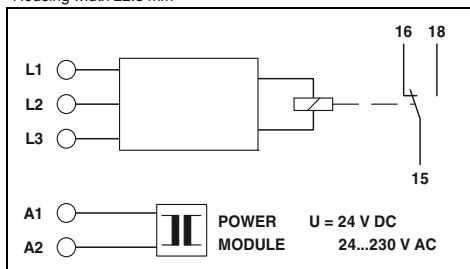

Technical data

EMD-SL-3V-400	EMD-SL-3V-400-N
Window, without neutral conductor connection	Window, with neutral conductor connection

280 V AC ... 520 V AC	280 V AC ... 520 V AC
3 ~ 400 V	3 N ~ 400/230 V
1 MΩ	1 MΩ
-30 % ... 20 % (From U _N)	
-20 % ... 30 % (From U _N)	
0.2 s ... 10 s	

± 5 % (of scale end value)
≤ 5 % (of scale end value)
≤ 2 %

1 floating PDT
750 VA (3 A/250 V AC, module aligned, ≤ 5 mm spacing)
1250 VA (5 A/250 V AC, module not aligned, ≥ 5 mm spacing)

2 x 10 ⁵ cycles at ohmic load, 1000 VA
Approx. 2x 10 ⁷ cycles
5 A (fast-blow)

24 V AC ... 230 V AC (see Power modules)
24 V DC (see Power modules)
2 VA (1.5 W)
IP40 (housing) / IP20 (connection terminal blocks)
-25 °C ... 55 °C
22.5 / 90 / 113 mm
0.5 ... 2.5 mm ² / 0.25 ... 2.5 mm ² / 20 - 14

CE-compliant
UL/C-UL listed UL 508

Ordering data

Type	Order No.	Pcs./ Pkt.
EMD-SL-3V-400	2866051	1
EMD-SL-3V-400-N	2885278	1
EMD-SL-PS- 24DC	2885359	1
EMD-SL-PS- 24AC	2866103	1
EMD-SL-PS-110AC	2866116	1
EMD-SL-PS-120AC	2885731	1
EMD-SL-PS-230AC	2866129	1



Housing width 22.5 mm

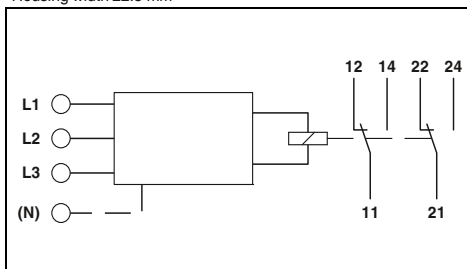

Technical data

Phase sequence, phase failure, asymmetry

342 V AC ... 457 V AC
3 N ~ 400/230 V
15 kΩ
-
-
≤ 350 ms (fixed setting)
Fixed, approx. 30 %
-
-
-

± 5 % (of scale end value)
≤ 5 % (of scale end value)
≤ 2 %

2 floating PDT contacts
750 VA (3 A/250 V AC, module aligned, ≤ 5 mm spacing)
1250 VA (5 A/250 V AC, module not aligned, ≥ 5 mm spacing)

2 x 10 ⁵ cycles at ohmic load, 1000 VA
Approx. 2x 10 ⁷ cycles
5 A (fast-blow)

From the measured voltage
-
9 VA
IP40 (housing) / IP20 (connection terminal blocks)
-25 °C ... 55 °C
22.5 / 90 / 113 mm
0.5 ... 2.5 mm ² / 0.25 ... 2.5 mm ² / 20 - 14

CE-compliant
UL/C-UL listed UL 508

Ordering data

Type	Order No.	Pcs./ Pkt.
EMD-SL-PH-400	2866077	1



Housing width 22.5 mm

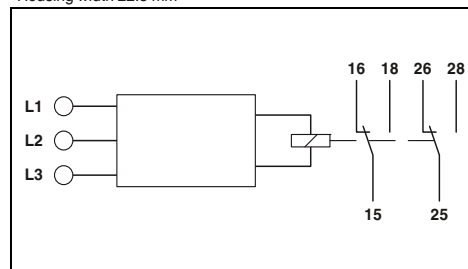

Technical data

Undervoltage, phase sequence, phase failure

177 V AC ... 794 V AC
3~ 208 V ... 690 V
-
-
-
0.1 s ... 10 s
25 %
≤ 3 % (of scale end value)
≤ 5 % (of scale end value)
≤ 2 %

± 5 % (of scale end value)
≤ 5 % (of scale end value)
≤ 2 %

2 floating PDT contacts
1250 VA (5 A/250 V AC at +55 °C)
150 VA (5 A/30 V DC at +55 °C)

2 x 10 ⁵ cycles
20 x 10 ⁶ cycles
5 A (fast-blow)

±15 % (= measuring voltage)
±15 % (= measuring voltage)
2 VA (1.2 W)
IP40 (housing) / IP20 (connection terminal blocks)
-25 °C ... 70 °C (C300)
22.5 / 90 / 113 mm
0.5 ... 2.5 mm ² / 0.5 ... 2.5 mm ² / 20 - 14

CE-compliant
UL/C-UL listed UL 508

Ordering data

Type	Order No.	Pcs./ Pkt.
EMD-SL-PH-690	2905597	1

Monitoring

Monitoring and diagnostics

Monitoring relays

Real power monitoring

The real power in single and three-phase networks is monitored with the **EMD-FL-RP-480** real power monitoring relay.

- Monitoring range up to 7.2 kW
- Separately adjustable startup and release delays
- Temperature monitoring of the motor winding
- Variable supply voltage range
- Detection of switched off loads

Load monitoring (cos φ)

The **EMD-FL-PF-400** monitoring relay is a cos φ monitor for load monitoring in single or three-phase networks.



Real power monitoring



Load monitoring (cos φ)

ERC

Housing width 45 mm

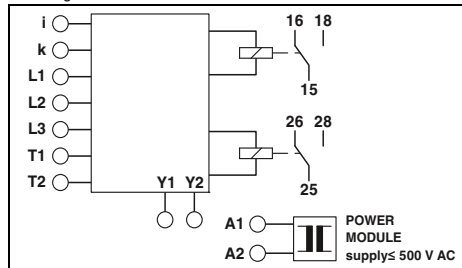

Technical data

Underload, overload, window, winding temperature monitoring

Voltage input
AC sine (10 Hz ... 400 Hz)
Can be switched between 0.75 kW, 1.5 kW, 3 kW and 6 kW

480 V (3 N ~ 480/277 V)
0 V AC ... 480 V AC (1(N) ~, single-phase load)
0 V AC ... 480 V AC (3(N) ~, 3-phase load)
0.15 A ... 6 A (Range: 0.75 kW and 1.5 kW)
0.3 A ... 12 A (Range: 3 kW and 6 kW)
5 % ... 110 % (of P_N)
10 % ... 120 % (of P_N)

Min.
Max.

Functions

Input

Description of the input
Measured value
Measuring ranges P_N

Nominal input voltage U_N
Input ranges

Input ranges

Minimum setting range
Maximum setting range
Switching threshold cos φ

Relay output

Contact type
Switching capacity

Electrical service life

Mechanical service life

Output fuse

General data

Supply voltage range

Nominal power consumption

Rated insulation voltage

Degree of protection

Ambient temperature (operation)

Dimensions W/H/D

Screw connection solid/stranded/AWG

EMC note

Conformance/Approvals

Conformance

UL, USA/Canada

ERC

Housing width 22.5 mm

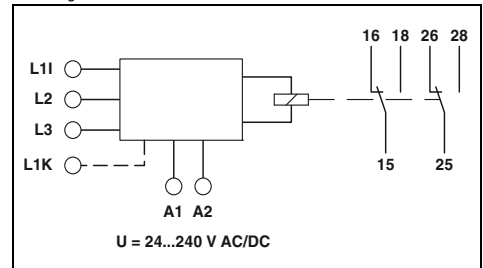

Technical data

Underload, overload, window

-
AC sine (10 ... 100 Hz)
-

3 N ~ 415/240 V
40 V AC ... 415 V AC (1(N) ~, single-phase load)
40 V AC ... 415 V AC (3(N) ~, 3-phase load)
0.5 A ... 10 A (Connection terminal blocks: L1i and L1k)

-
0.1 ... 0.99
0.2 ... 1

2 floating PDT contacts

750 VA (3 A/250 V AC, module aligned, ≤ 5 mm spacing)
1250 VA (5 A/250 V AC, module not aligned, ≥ 5 mm spacing)

2 x 10⁵ cycles at ohmic load, 1000 VA

Approx. 2x 10⁷ cycles

5 A (fast-blow)

24 V AC ... 240 V AC -15 % ... +10 %
24 V DC ... 240 V DC (-20 % ... +25 %)

4.5 VA (1.5 W)

300 V (According to EN 50178)

IP40 (housing) / IP20 (connection terminal blocks)

-25 °C ... 55 °C

22.5 / 90 / 113 mm

0.5 ... 2.5 mm² / 0.25 ... 2.5 mm² / 20 - 14

Class A product, see page 605

CE-compliant

UL/C-UL listed UL 508

Ordering data

Description

Electronic monitoring relay

Power module, plug-in, please order at the same time!

Supply voltage 88 ... 121 V AC

Supply voltage 108 ... 132 V AC

Supply voltage 195 ... 264 V AC

Supply voltage 323 ... 456 V AC

Supply voltage 425 ... 550 V AC

Type

Order No.

Pcs./
Pkt.

EMD-FL-RP-480

2900177

1

EMD-SL-PS45-110AC

2885281

1

EMD-SL-PS45-120AC

2885744

1

EMD-SL-PS45-230AC

2885294

1

EMD-SL-PS45-400AC

2885304

1

EMD-SL-PS45-500AC

2885317

1

Ordering data

Type

Order No.

Pcs./
Pkt.

EMD-FL-PF-400

2885809

1

Level monitoring

The **EMD-SL-LL-...** monitoring relay monitors the level of electrically conductive liquids with the help of conductive probes (not supplied as standard).
 – Adjustable response delay
 – Adjustable via potentiometer on front

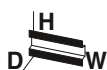

Temperature monitoring (motor windings)



Level monitoring

Housing width 22.5 mm

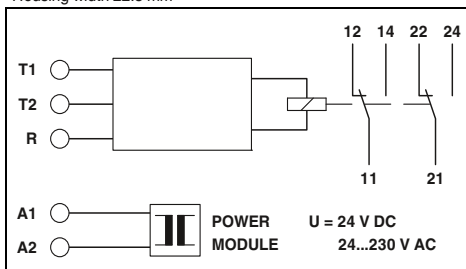

Technical data

Winding temperature monitoring

Input	
Total cold resistance	< 1.5 kΩ
Response value	≥ 3.6 kΩ (Relay drops out)
Release value	≤ 1.8 kΩ (Relay picks up)
Basic accuracy	± 10 % (of scale end value)
Repeat accuracy	≤ 2 %
Measuring input	-
Maximum probe voltage	-
Maximum probe current	-
Length of probe cable	-
Switching threshold	-
Relay output	
Contact type	2 floating PDT contacts
Switching capacity	750 VA (3 A/250 V AC, module aligned, ≤ 5 mm spacing) 1250 VA (5 A/250 V AC, module not aligned, ≥ 5 mm spacing)
Electrical service life	2 x 10 ⁵ cycles at ohmic load, 1000 VA
Mechanical service life	Approx. 2x 10 ⁷ cycles
Output fuse	5 A (fast-blow)
General data	
Supply voltage	24 V AC ... 230 V AC (see Power modules)
Supply voltage range	24 V DC (see Power modules)
Nominal power consumption	2 VA (1.5 W)
Degree of protection	IP40 (housing) / IP20 (connection terminal blocks)
Ambient temperature (operation)	-25 °C ... 55 °C
Dimensions W/H/D	22.5 / 90 / 113 mm
Screw connection solid/stranded/AWG	0.5 ... 2.5 mm ² / 0.25 ... 2.5 mm ² / 20 - 14
EMC note	Class A product, see page 605
Conformance/Approvals	
Conformance	CE-compliant
UL, USA/Canada	UL/C-UL listed UL 508

Housing width 22.5 mm

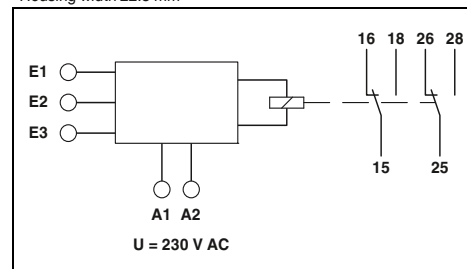

Technical data

Pumping up (minimum monitoring),
pumping down (maximum monitoring)

Input	
Conductive probe, type: SK1, SK2, SK3	
16 V AC	
7 mA	
< 1000 m (Line capacity 100 nF/km; set value < 50%)	
< 100 m (Line capacity 100 nF/km; set value 100%)	
0.25 kΩ ... 100 kΩ (4 mS ... 1 μS)	
Relay output	
Contact type	2 floating PDT contacts
Switching capacity	750 VA (3 A/250 V AC, module aligned, ≤ 5 mm spacing) 1250 VA (5 A/250 V AC, module not aligned, ≥ 5 mm spacing)
Electrical service life	2 x 10 ⁵ cycles at ohmic load, 1000 VA
Mechanical service life	Approx. 2x 10 ⁷ cycles
Output fuse	5 A (fast-blow)
General data	
EMD-SL-LL-230	EMD-SL-LL-110
230 V AC -15 % ... +15 % AC	110 V AC -10 % ... +15 % AC
2 VA (1.5 W)	
IP40 (housing) / IP20 (connection terminal blocks)	
-25 °C ... 55 °C	
22.5 / 90 / 113 mm	
0.5 ... 2.5 mm ² / 0.25 ... 2.5 mm ² / 20 - 14	
CE-compliant	
UL/C-UL listed UL 508	

Functions

Input

- Total cold resistance
- Response value
- Release value
- Basic accuracy
- Repeat accuracy
- Measuring input
- Maximum probe voltage
- Maximum probe current
- Length of probe cable

Switching threshold

Relay output

Contact type

Switching capacity

Electrical service life

Mechanical service life

Output fuse

General data

Supply voltage

Supply voltage range

Nominal power consumption

Degree of protection

Ambient temperature (operation)

Dimensions W/H/D

Screw connection solid/stranded/AWG

EMC note

Conformance/Approvals

Conformance

UL, USA/Canada

Ordering data

Description

Electronic monitoring relay

Power module, plug-in, please order at the same time!

- Supply voltage 20 ... 30 V DC
- Supply voltage 20.2 ... 26.4 V AC
- Supply voltage 88 ... 121 V AC
- Supply voltage 108 ... 132 V AC
- Supply voltage 195 ... 264 V AC

Type	Order No.	Pcs./ Pkt.
EMD-SL-PTC	2866093	1
EMD-SL-PS- 24DC	2885359	1
EMD-SL-PS- 24AC	2866103	1
EMD-SL-PS-110AC	2866116	1
EMD-SL-PS-120AC	2885731	1
EMD-SL-PS-230AC	2866129	1

Ordering data

Type	Order No.	Pcs./ Pkt.
EMD-SL-LL-230	2885906	1
EMD-SL-LL-110	2901137	1

Monitoring

Monitoring and diagnostics

Compact time relay

The multifunctional time relay offers universal use thanks to a variety of functions and various time settings. The rotary switches on the front of the housing allow easy parameterization. The compact design also allows flexible use.

Main features:

- Adjustable time
- Time range: 50 ms to 1 h
- Non-floating control input
- Delay functions
- Wiper functions
- Output: one floating changeover contact
- Clear diagnostics via status LED



Multifunctional time relay

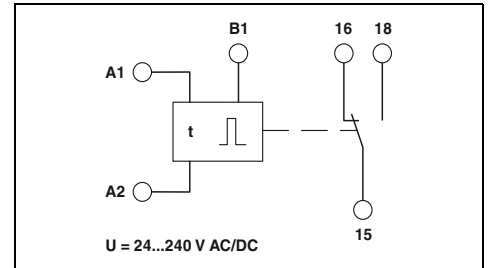

Technical data

E: With switch-on delay
 R: With release delay and control contact
 Es: With switch-on delay and control contact
 Ws: With single shot leading edge and control contact

Functions

Control contact	
Connection	Non-floating, terminals A1-B1
Control pulse length	≥ 50 ms (DC)
Relay output	
Contact type	1 floating PDT
Switching capacity	1250 VA (5 A/250 V AC)
Mechanical service life	15 x 10 ⁶ cycles
General data	
Supply voltage	24 V DC ... 240 V DC -20 % ... +25 %
Degree of protection	IP40 (housing) / IP20 (connection terminal blocks)
Ambient temperature range	-25 °C ... 55 °C
Dimensions W/H/D	17.5 / 88 / 65.5 mm
Push-in connection solid/stranded/AWG	0.14 ... 2.5 mm ² / 0.14 ... 2.5 mm ² / 26 - 14
Screw connection solid/stranded/AWG	0.5 ... 2.5 mm ² / 0.5 ... 2.5 mm ² / 20 - 14
Conformance/Approvals	
Conformance	CE-compliant
UL, USA/Canada	UL 508 Listed

Ordering data

Description	
Compact time relay, multifunctional, with screw connection	
Compact time relay, multifunctional, with Push-in connection	

Type	Order No.	Pcs./Pkt.
ETD-BL-1T-230	2905813	1
ETD-BL-1T-230-PT	2905814	1

Compact time relay

As an impulse encoder with adjustable times, the ETD-BL-2T-I-230 offers a range of flashing functions. The rotary switches on the front of the housing allow easy parameterization. The compact design also allows flexible use.

Main features:

- Two adjustable times
- Time ranges: 50 ms to 100 h
- Flashing function
- Wide-range power supply unit
- Output: two floating changeover contacts
- Clear diagnostics via status LED



Impulse encoder,
adjustable pulse and pause times

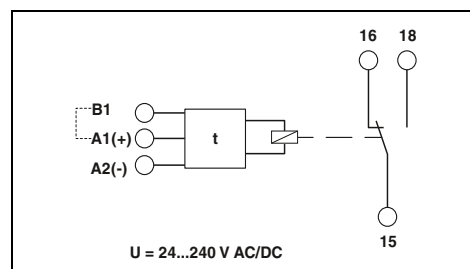

Technical data

Functions	
Time ranges	50 ms ... 100 h (7 time end ranges)
Setting range	
Control contact	Non-floating, terminals A1-B1
Connection	≥ 50 ms (DC)
Control pulse length	
Relay output	1 floating PDT
Contact type	750 VA (3 A/250 V AC, module aligned, ≤ 5 mm spacing)
Switching capacity	1250 VA (5 A/250 V AC, module not aligned, ≥ 5 mm spacing)
Mechanical service life	Approx. 2x 10 ⁷ cycles
General data	
Supply voltage	24 V DC ... 240 V DC -10 % ... +15 %
Nominal power consumption	2.5 VA (1 W)
Degree of protection	IP40 (housing) / IP20 (connection terminal blocks)
Ambient temperature range	-25 °C ... 55 °C
Dimensions W/H/D	17.5 / 88 / 65.5 mm
Push-in connection solid/stranded/AWG	0.14 ... 2.5 mm ² / 0.14 ... 2.5 mm ² / 26 - 14
Screw connection solid/stranded/AWG	0.5 ... 2.5 mm ² / 0.5 ... 2.5 mm ² / 20 - 14
Conformance/Approvals	
Conformance	CE-compliant

lp: Switched-mode beginning with the pause
li: Switched-mode beginning with the pulse

Ordering data

Description	Type	Order No.	Pcs./Pkt.
Compact time relay, impulse encoder			
- with Push-in connection	ETD-BL-2T-I-230-PT	2907714	1
- with screw connection	ETD-BL-2T-I-230	2907713	1

Monitoring

Monitoring and diagnostics

Plug-in timer module for RIF-1, RIF-2, RIF-3, and RIF-4

The multifunctional plug-in timer module transforms a relay module into a time relay. RIF-1 to RIF-4 bases can be equipped with this module. Using DIP switches, three time functions and four time ranges can be selected. Detailed time settings are made using a potentiometer. Relays can be operated with an input voltage of 12 or 24 V AC/DC.

The time functions:

- With switch-on delay
- With passing make contact
- Pulse generator

Time ranges:

- 0.5 to 10 s
- 5 to 100 s
- 0.5 to 10 min
- 5 to 100 min



Timer module for RIF-1 to RIF-4 relay modules for 12 to 24 V AC/DC input voltage

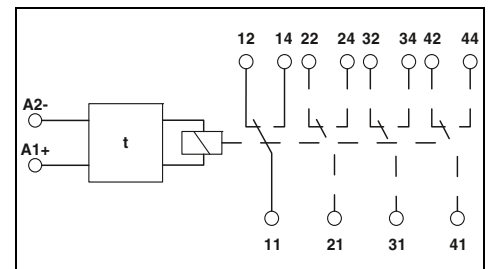

With switch-on delay

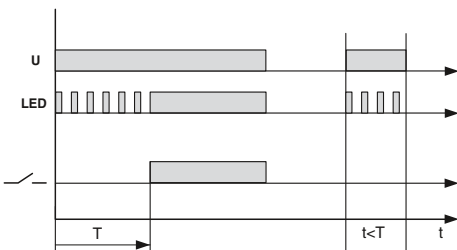

Passing make contact

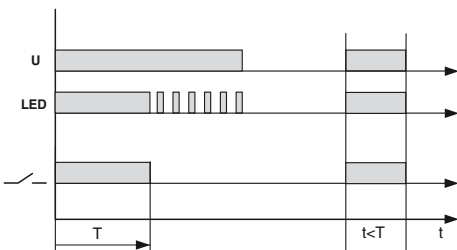

Pulse generator

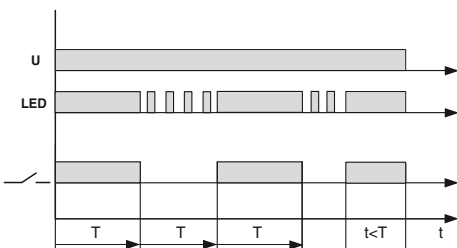

Input data
Nominal input voltage U_N
Nominal input voltage range with reference to U_N
Input circuit
Output data
Limiting continuous current
General data
Mounting position
Repeat accuracy
Ambient temperature (operation)
Standards/specifications
Rated insulation voltage
Rated surge voltage

Technical data
24 V DC (AC operation only permitted for RIF-1)
0.4 ... 1.2
Varistor, Yellow LED
≤ 250 mA (Relay coil current)
any
1 %
-25 °C ... 50 °C (RIF-1, AC coil, 2 PDTs at 6 A)
-25 °C ... 50 °C (RIF-1, DC coil, 2 PDTs at 5 A)
-25 °C ... 40 °C (RIF-2, DC coil, 2 PDTs at 8 A)
-25 °C ... 40 °C (RIF-2, DC coil, 4 PDTs at 5 A)
-25 °C ... 40 °C (RIF-3, DC coil, 3 PDTs at 6.75 A)
-25 °C ... 40 °C (RIF-3, DC coil, 2 PDTs at 8 A)
-25 °C ... 35 °C (RIF-4, DC coil, 3 PDTs at 8 A)
-25 °C ... 25 °C (RIF-4, DC coil, 3 N/O contacts at 8 A)
DIN EN 50178
50 V DC
0.4 kV

Description
Timer module , for mounting on RIF-1 to RIF-4, with LED status indicator for extending a relay module to create a time relay with an input voltage of 24 V AC/DC

Ordering data		
Type	Order No.	Pcs./Pkt.
RIF-T3-24UC	2902647	1

Ultra-narrow time relays

The **ETD-BL-1T...** ultra-narrow time relays show their strengths in applications that involve set parameters for functionality and time range.

- Purposeful device selection: one function, one time range
- High level of setting accuracy thanks to labeled and illuminated thumb wheel
- Overall width of just 6.2 mm



Time relay with switch-on delay, voltage controlled

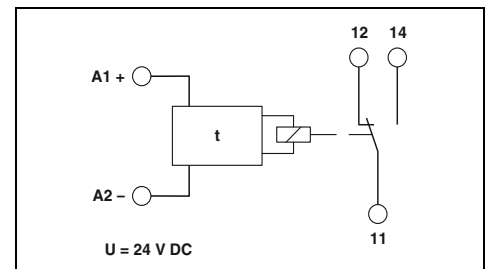

Technical data

Functions	
Control contact	-
Connection	-
Control pulse length	min. 50 ms
Relay output	
Contact type	1 floating PDT
Switching capacity	1500 VA (6 A / 250 V AC)
Mechanical service life	Approx. 2x 10 ⁷ cycles
General data	
Supply voltage	24 V DC (19.2 V DC ... 30 V DC)
Typical nominal current	15 mA (Relay ON) 7 mA (Relay OFF)
Impulse withstand voltage	6 kV (According to EN 50178)
Degree of protection	IP20
Ambient temperature range	-20 °C ... 65 °C
Dimensions W/H/D	6.2 / 80 / 86 mm
Screw connection solid/stranded/AWG	0.14 ... 2.5 mm ² / 0.14 ... 2.5 mm ² / 30 - 12
Push-in connection solid/stranded/AWG	0.14 ... 2.5 mm ² / 0.14 ... 2.5 mm ² / 26 - 14
Conformance/Approvals	
Conformance	CE-compliant
ATEX	Ex II 3 G Ex nA nC IIC T4 Gc X
UL, USA/Canada	UL/C-UL listed UL 508

ON: With switch-on delay

Ordering data

Description	
Compact time relay, with screw connection	
Time range 0.1...10 s	
Time range 3...300 s	
Time range 0.3...30 min	
Time range 3...300 min	
Compact time relay, with Push-in connection	
Time range 0.1...10 s	
Time range 3...300 s	
Time range 0.3...30 min	
Time range 3...300 min	

Type	Order No.	Pcs./Pkt.
ETD-BL-1T-ON- 10S	2917379	1
ETD-BL-1T-ON-300S	2917382	1
ETD-BL-1T-ON- 30MIN	2917395	1
ETD-BL-1T-ON-300MIN	2917405	1
ETD-BL-1T-ON- 10S-PT	2901476	1
ETD-BL-1T-ON-300S-PT	2901477	1
ETD-BL-1T-ON- 30MIN-PT	2901478	1
ETD-BL-1T-ON-300MIN-PT	2901479	1

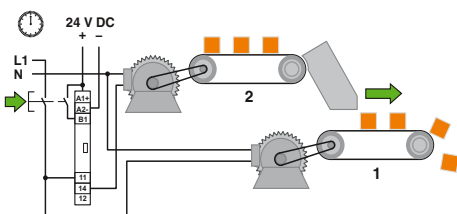

Conveyor belt 1 starts immediately

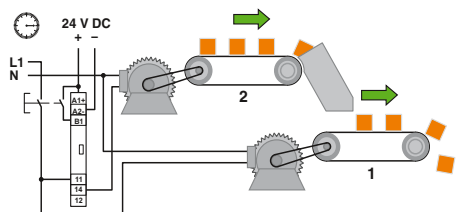

Conveyor belt 2 starts with a time delay



Time relay with switch-on delay, with control contact



Time relay with off delay, with control contact



Time relay with flashing indic. function, beginning with the pulse

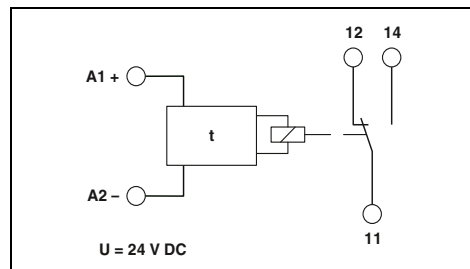
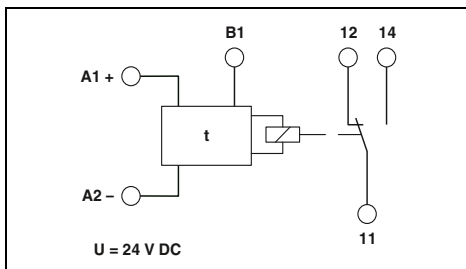
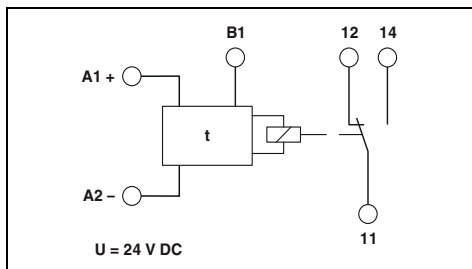

Technical data

Technical data

Technical data

ON-CC: With switch-on delay with control contact

OFF-CC: Off delay with control contact

F: Flashing beginning with pulse

Non-floating, terminals A1-B1
min. 50 ms

Non-floating, terminals A1-B1
min. 50 ms

-
min. 50 ms

1 floating PDT
1500 VA (6 A / 250 V AC)
Approx. 2x 10⁷ cycles

1 floating PDT
1500 VA (6 A / 250 V AC)
Approx. 2x 10⁷ cycles

1 floating PDT
1500 VA (6 A / 250 V AC)
Approx. 2x 10⁷ cycles

24 V DC (19.2 V DC ... 30 V DC)
15 mA (Relay ON)
7 mA (Relay OFF)
6 kV (According to EN 50178)
IP20
-20 °C ... 65 °C
6.2 / 80 / 86 mm
0.14 ... 2.5 mm² / 0.14 ... 2.5 mm² / 30 - 12
0.14 ... 2.5 mm² / 0.14 ... 2.5 mm² / 26 - 14

24 V DC (19.2 V DC ... 30 V DC)
15 mA (Relay ON)
7 mA (Relay OFF)
6 kV (According to EN 50178)
IP20
-20 °C ... 65 °C
6.2 / 80 / 86 mm
0.14 ... 2.5 mm² / 0.14 ... 2.5 mm² / 30 - 12
0.14 ... 2.5 mm² / 0.14 ... 2.5 mm² / 26 - 14

24 V DC (19.2 V DC ... 30 V DC)
15 mA (Relay ON)
7 mA (Relay OFF)
6 kV (According to EN 50178)
IP20
-20 °C ... 65 °C
6.2 / 80 / 86 mm
0.14 ... 2.5 mm² / 0.14 ... 2.5 mm² / 30 - 12
0.14 ... 2.5 mm² / 0.14 ... 2.5 mm² / 26 - 14

CE-compliant
Ex II 3 G Ex nA nC IIC T4 Gc X
UL/C-UL listed UL 508

CE-compliant
Ex II 3 G Ex nA nC IIC T4 Gc X
UL/C-UL listed UL 508

CE-compliant
Ex II 3 G Ex nA nC IIC T4 Gc X
UL/C-UL listed UL 508

Ordering data

Ordering data

Ordering data

Type	Order No.	Pcs./ Pkt.
ETD-BL-1T-ON-CC- 10S	2917418	1
ETD-BL-1T-ON-CC-300S	2917421	1
ETD-BL-1T-ON-CC- 30MIN	2917434	1
ETD-BL-1T-ON-CC-300MIN	2917447	1
ETD-BL-1T-ON-CC- 10S-PT	2901480	1
ETD-BL-1T-ON-CC-300S-PT	2901481	1
ETD-BL-1T-ON-CC- 30MIN-PT	2901483	1
ETD-BL-1T-ON-CC-300MIN-PT	2901484	1

Type	Order No.	Pcs./ Pkt.
ETD-BL-1T-OFF-CC- 10S	2917450	1
ETD-BL-1T-OFF-CC-300S	2917463	1
ETD-BL-1T-OFF-CC- 30MIN	2917467	1
ETD-BL-1T-OFF-CC-300MIN	2917489	1
ETD-BL-1T-OFF-CC- 10S-PT	2901485	1
ETD-BL-1T-OFF-CC-300S-PT	2901486	1
ETD-BL-1T-OFF-CC- 30MIN-PT	2901487	1
ETD-BL-1T-OFF-CC-300MIN-PT	2901488	1

Type	Order No.	Pcs./ Pkt.
ETD-BL-1T-F- 10S	2917492	1
ETD-BL-1T-F-300S	2917502	1
ETD-BL-1T-F- 30MIN	2917515	1
ETD-BL-1T-F-300MIN	2917528	1
ETD-BL-1T-F- 10S-PT	2901489	1
ETD-BL-1T-F-300S-PT	2901490	1
ETD-BL-1T-F- 30MIN-PT	2901491	1
ETD-BL-1T-F-300MIN-PT	2901492	1

Monitoring

Monitoring and diagnostics

Multifunctional time relays

The full range of conventional applications can be accommodated by the three versions of the **ETD** multifunctional time relay.

- Suitable for universal use thanks to varied functions and selectable time ranges
- Time ranges from a few milliseconds to several days
- Variable supply voltage range
- 2 floating PDT outputs



**Multifunctional time relay,
two adjustable times**



Housing width 22.5 mm

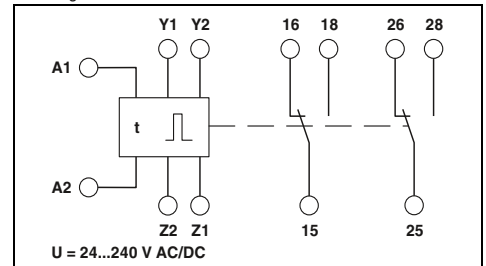

Technical data

Functions

- Ip: Switched-mode beginning with the pause
- Ii: Switched-mode beginning with the pulse
- ER: With switch-on and release delay with control contact
- EWu: With switch-on delay and single shot leading edge, voltage controlled
- EWs: With switch-on delay and single shot leading edge with control contact
- WsWa: With single shot leading edge and single shot trailing edge with control contact
- Wt: Pulse sequence evaluation (retriggerable release delay)

Time ranges

- Setting range
- Control contact
- Connection

50 ms ... 10 h (10 time end ranges)

Load capacity

Floating, basic isolation between connection and input/output/bridge Y1-Y2
Cannot carry load

- Cable length
- Control pulse length
- Relay output
- Contact type
- Switching capacity

< 10 m
min. 50 ms (Only with Wt function: > 7 ms)
2 floating PDT contacts
750 VA (3 A/250 V AC, module aligned, ≤ 5 mm spacing)
1250 VA (5 A/250 V AC, module not aligned, ≥ 5 mm spacing)

Mechanical service life

Approx. 2×10^7 cycles

- General data
- Supply voltage

24 V DC ... 240 V DC -20 % ... +25 %
24 V AC ... 240 V AC -15 % ... +10 %
2.5 VA (1 W)
IP40 (housing) / IP20 (connection terminal blocks)

- Nominal power consumption
- Degree of protection
- Ambient temperature range
- Housing material
- Dimensions W/H/D
- Screw connection solid/stranded/AWG
- EMC note

-25 °C ... 55 °C
Polyamide PA, self-extinguishing
22.5 / 90 / 113 mm
0.5 ... 2.5 mm² / 0.5 ... 2.5 mm² / 20 - 14
Class A product, see page 605

- Conformance/Approvals
- Conformance
- UL, USA/Canada

CE-compliant
UL/C-UL listed UL 508

Ordering data

Description

Electronic time relay with adjustable functions and times

Type	Order No.	Pcs./Pkt.
ETD-FL-2T-DTI	2866187	1

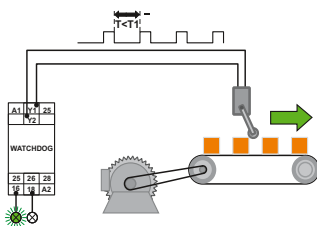

Function: Pulse sequence evaluation

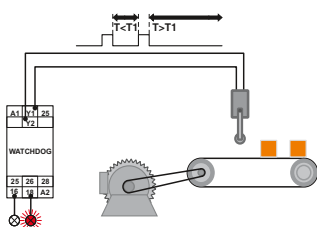

Message for incorrect pulse



**Multifunctional time relay,
one adjustable time**



**Impulse encoder,
adjustable pulse and pause times**



Housing width 22.5 mm

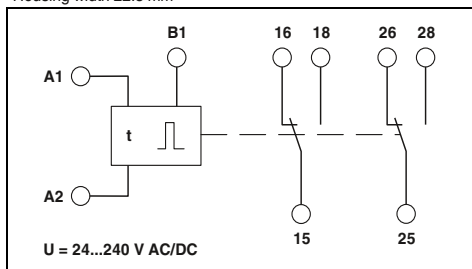

Technical data

- E: With switch-on delay
- R: With release delay and control contact
- Es: With switch-on delay and control contact
- Wu: With single shot leading edge, voltage controlled
- Ws: With single shot leading edge and control contact
- Wa: With single shot trailing edge and control contact
- Bi: Flashing beginning with pulse
- Bp: Flashing beginning with pause

50 ms ... 100 h (7 time end ranges)

Non-floating, terminals A1-B1

Parallel switched minimum load current 1 VA (0.5 W), terminals A2-B1

< 10 m
min. 70 ms

2 floating PDT contacts
750 VA (3 A/250 V AC, module aligned, ≤ 5 mm spacing)
1250 VA (5 A/250 V AC, module not aligned, ≥ 5 mm spacing)

Approx. 2x 10⁷ cycles

24 V DC ... 240 V DC -20 % ... +25 %
24 V AC ... 240 V AC -15 % ... +10 %
2.5 VA (1 W)
IP40 (housing) / IP20 (connection terminal blocks)

-25 °C ... 55 °C
Polyamide PA, self-extinguishing
22.5 / 90 / 113 mm
0.5 ... 2.5 mm² / 0.5 ... 2.5 mm² / 20 - 14
Class A product, see page 605

CE-compliant
UL/C-UL listed UL 508

Ordering data

Type	Order No.	Pcs./ Pkt.
ETD-SL-1T-DTF	2866161	1



Housing width 22.5 mm

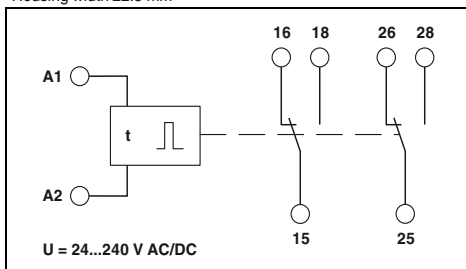

Technical data

- Ip: Switched-mode beginning with the pause
- Ii: Switched-mode beginning with the pulse

50 ms ... 100 h (7 time end ranges)

-

-

-
-

2 floating PDT contacts
750 VA (3 A/250 V AC, module aligned, ≤ 5 mm spacing)
1250 VA (5 A/250 V AC, module not aligned, ≥ 5 mm spacing)

Approx. 2x 10⁷ cycles

24 V DC ... 240 V DC -20 % ... +25 %
24 V AC ... 240 V AC -15 % ... +10 %
2.5 VA (1 W)
IP40 (housing) / IP20 (connection terminal blocks)

-25 °C ... 55 °C
Polyamide PA, self-extinguishing
22.5 / 90 / 113 mm
0.5 ... 2.5 mm² / 0.5 ... 2.5 mm² / 20 - 14
Class A product, see page 605

CE-compliant
UL/C-UL listed UL 508

Ordering data

Type	Order No.	Pcs./ Pkt.
ETD-SL-2T-I	2866174	1

Diode module

Diode circuits perform various tasks in electrical control systems, particularly in electronic ones:

- Electrical decoupling of messages in fault signaling systems
- Spark-suppression diodes for limiting surge voltages of inductive loads, (solenoid valves, DC relays or similar)
- Can be supplied as “diode gates” combined with anode or cathode or as freely assignable diodes



with diode type 1 N 4007



with diode type 1 N 5408

Notes:
Further circuit diagrams can be found in the data sheet at phoenixcontact.net/products.

ERC

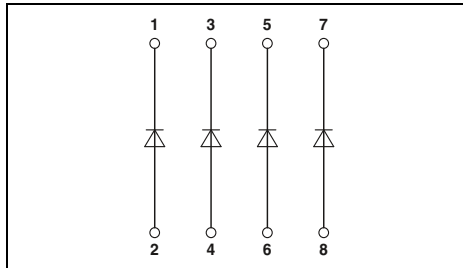

ERC

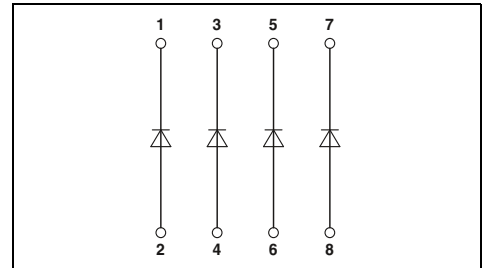

Diodes	
Max. operating voltage U_{max}	250 V AC
Peak reverse voltage per diode	1300 V
Reverse current per diode	5 μ A
Conducting state voltage per diode	approx. 0.8 V
Conducting state current per diode	
	with single load
	with simultaneous loads
General data	
Ambient temperature range	-20 °C ... 50 °C
Rated insulation voltage	300 V (According to EN 50178)
Degree of pollution / Overvoltage category	III, basic insulation (as per EN 50178)
Degree of pollution / Overvoltage category	2 (according to EN 50178)
Mounting position	any
Mounting	In rows with zero spacing
Dimensions H / D	75 / 55 mm
Screw connection solid/stranded/AWG	0.2 ... 4 mm ² / 0.2 ... 2.5 mm ² / 24 - 12
Conformance/Approvals	
Conformance	CE-compliant

Technical data	
4E / 8E / 17E / 7P / 7M	14P / 14M / 32P / 32M
250 V AC	250 V AC
1300 V	1300 V
5 μ A	5 μ A
approx. 0.8 V	approx. 0.8 V
	with single load
	with simultaneous loads
0.7 A	0.7 A
0.5 A	0.2 A
General data	
Ambient temperature range	-20 °C ... 50 °C
Rated insulation voltage	300 V (According to EN 50178)
Degree of pollution / Overvoltage category	III, basic insulation (as per EN 50178)
Degree of pollution / Overvoltage category	2 (according to EN 50178)
Mounting position	any
Mounting	In rows with zero spacing
Dimensions H / D	75 / 55 mm
Screw connection solid/stranded/AWG	0.2 ... 4 mm ² / 0.2 ... 2.5 mm ² / 24 - 12
Conformance/Approvals	
Conformance	CE-compliant

Technical data	
4E-... / 4P-... / 4M-... / 8E-...	8P-... / 8M-...
250 V AC	250 V AC
1000 V	1000 V
10 μ A	10 μ A
approx. 0.8 V	approx. 0.8 V
	with single load
	with simultaneous loads
1.5 A	1.5 A
1 A	0.3 A
General data	
Ambient temperature range	-20 °C ... 50 °C
Rated insulation voltage	300 V (According to EN 50178)
Degree of pollution / Overvoltage category	III, basic insulation (as per EN 50178)
Degree of pollution / Overvoltage category	2 (according to EN 50178)
Mounting position	any
Mounting	In rows with zero spacing
Dimensions H / D	75 / 55 mm
Screw connection solid/stranded/AWG	0.2 ... 4 mm ² / 0.2 ... 2.5 mm ² / 24 - 12
Conformance/Approvals	
Conformance	CE-compliant

Description	Housing width
Diode module, can be individually wired	
4 diodes	22.5 mm
8 diodes	45 mm
17 diodes	90 mm
Diode module, with P polarity (common cathode)	
4 diodes	22.5 mm
7 diodes	22.5 mm
8 diodes	45 mm
14 diodes	45 mm
32 diodes	90 mm
Diode module, with M polarity (common anode)	
4 diodes	22.5 mm
7 diodes	22.5 mm
8 diodes	45 mm
14 diodes	45 mm
32 diodes	90 mm

Ordering data		
Type	Order No.	Pcs./ Pkt.
EMG 22-DIO 4E	2950048	10
EMG 45-DIO 8E	2950103	5
EMG 90-DIO 17E	2954895	5
EMG 22-DIO 7P	2950064	10
EMG 45-DIO14P	2950116	5
EMG 90-DIO 32P	2954918	5
EMG 22-DIO 7M	2950077	10
EMG 45-DIO14M	2950129	5
EMG 90-DIO 32M	2954934	5

Ordering data		
Type	Order No.	Pcs./ Pkt.
EMG 22-DIO 4E-1N5408	2952790	10
EMG 45-DIO 8E-1N5408	2949389	5
EMG 22-DIO 4P-1N5408	2952198	10
EMG 45-DIO 8P-1N5408	2954879	5
EMG 22-DIO 4M-1N5408	2952211	10
EMG 45-DIO 8M-1N5408	2954882	5

Accessories	
Equipment marker	Order No.
EMG-GKS 12	2947035

Accessories	
Equipment marker	Order No.
EMG-GKS 12	2947035

Accessories	
Equipment marker	Order No.
EMG-GKS 12	2947035

Lamp testing modules

Lamp testing modules for checking lamps that are installed and ready for operation:

- Individual checking of separate lamps (EMG...-E/LP)
- Centrally controlled checking of lamps (EMG...-M/LP)

Display modules

- Light indicator modules facilitate the monitoring of processes on electronic control systems during troubleshooting



Lamp testing module, groups of 2 diodes with common cathode



Light indicator module, with common return line

Notes:

Further circuit diagrams can be found in the data sheet at phoenixcontact.net/products.

ERC

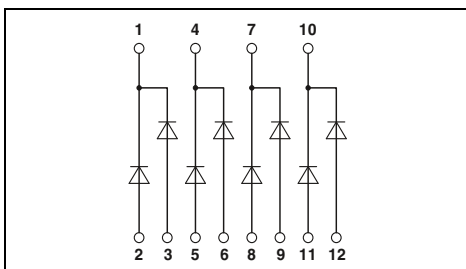

ERC

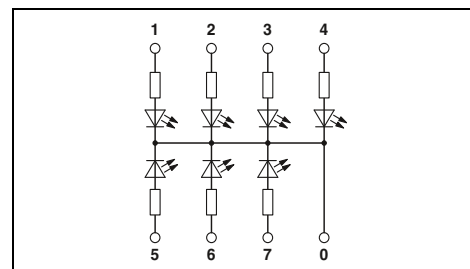

Diods	
Max. operating voltage U_{max}	
Peak reverse voltage per diode	
Reverse current per diode	
Conducting state voltage per diode	
Conducting state current per diode	

Technical data	
8E/16E	14M/32M
250 V AC	250 V AC
1300 V	1300 V
$\leq 5 \mu A$	$\leq 5 \mu A$
approx. 0.8 V	approx. 0.8 V
with single load	0.7 A
with simultaneous loads	0.4 A

Technical data	
LA 7S	LED 7S/LED 14S
	approx. 1 mA
	approx. 3 mA

Input	
Current required per light indicator	
General data	
Ambient temperature range	-20 °C ... 50 °C
Rated insulation voltage	300 V (According to EN 50178)
Degree of pollution / Overvoltage category	III, basic insulation (as per EN 50178)
Degree of pollution / Overvoltage category	2 (according to EN 50178)
Mounting position	any
Mounting	In rows with zero spacing
Dimensions H / D	75 / 55 mm
Screw connection solid/stranded/AWG	0.2 ... 4 mm ² / 0.2 ... 2.5 mm ² / 24 - 12
Conformance/Approvals	
Conformance	CE-compliant

	-20 °C ... 45 °C
	III, basic insulation (as per EN 50178)
	2 (according to EN 50178)
	any
	In rows with zero spacing
	75 / 47.5 mm
	0.2 ... 4 mm ² / 0.2 ... 2.5 mm ² / 24 - 12
	CE-compliant

Description	Housing width
Lamp testing module, for individual wiring	
4-pair	45 mm
8-pair	90 mm
Lamp testing module, with common control	
7-pair	45 mm
16-pair	90 mm
Light indicator module, 110 ... 230 V AC input voltage	
7 glow lamps	22.5 mm
Light indicator module, 24 V DC input voltage	
7 LEDs	22.5 mm
14 LEDs	45 mm

Ordering data		
Type	Order No.	Pcs./Pkt.
EMG 45-DIO 8E/LP	2954798	5
EMG 90-DIO 16E/LP	2954808	5
EMG 45-DIO14M/LP	2950132	5
EMG 90-DIO 32M/LP	2954785	5

Ordering data		
Type	Order No.	Pcs./Pkt.
EMG 22-LA 7S/230	2949677	10
EMG 22-LED 7S/24	2952305	10
EMG 45-LED 14S/24	2952334	5

Equipment marker	
------------------	--

Accessories		
EMG-GKS 12	2947035	50

Accessories		
EMG-GKS 12	2947035	50



Relay modules

The importance of the reliability of industrial automation equipment is growing with the increase in use of electronic modules.

Modern relays or solid-state relay interfaces perform a wide range of tasks. No matter what the field – production technology, electrical equipment for machines, control engineering for power distribution, building automation, or process engineering – the aim is to ensure signal exchange between process peripherals and the higher-level central control systems. And this exchange must be reliable, floating, and electrically unambiguous. Safe electrical interface modules that meet the requirements of modern system concepts must include the following features:

- Coupling of different signal levels
- Safe electrical isolation between input and output
- High resistance to interference

In practice, a relay interface is used in applications that require a flexible interface configuration with a large switching capacity range and the possibility of combining different types of contact. Further important features of relay interfaces are:

- Electrical isolation between open contacts
- Switching of independent switching current types
- High short-term overload resistance in the event of a short circuit or voltage peaks
- Practically impervious to electromagnetic fields
- Easy handling

Solid-state relay modules are used when an interface between the process peripherals and electronics is subject to the following requirements:

- Low control power
- High switching frequencies
- Wear-resistant and bounce-free switching
- Resistance to vibrations and shocks
- Long service life

Product range overview

Product overview	284
Basics of relay technology	286
Basics of solid-state relay technology	290
Sensor/actuator configuration aids and handling of interference signals	292
Industrial relay system - RIFLINE complete	294
Highly compact relay modules - PLC-INTERFACE	368
Programmable logic relay system - PLC logic	426
Relay modules in terminal block design - DEK series	436
Special relay and solid-state relay modules	442
Relay modules with force-guided contacts	456
Relay modules for potentially explosive areas (Zone 2)	458

Relay modules

Product overview

RIFLINE complete



RIF-0 for relays and solid-state relays
Page 296



RIF-1 for relays and solid-state relays
Page 302



RIF-2 for industrial relays
Page 312



RIF-3 for octal relays
Page 318

PLC-INTERFACE



With relay/solid-state relay
Page 372
As sensor/actuator version
Page 378



For high inrush/continuous currents
Page 386
Resistant to interference currents/voltages
Page 388



With switch
Page 404
For railway applications
Page 415



For NAMUR initiators
Page 420
Types of electronics
Page 421

DEK series

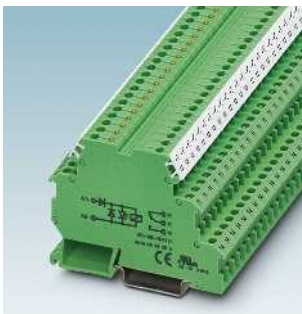

With miniature relay
Page 437

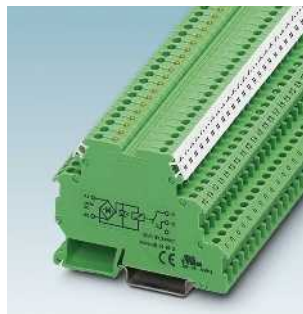

Actuator series with miniature relays
Page 439

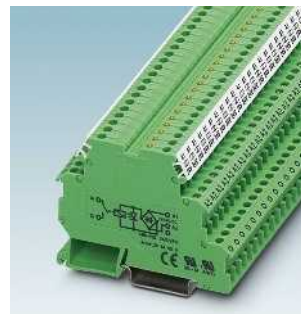

Sensor series with miniature relays
Page 439

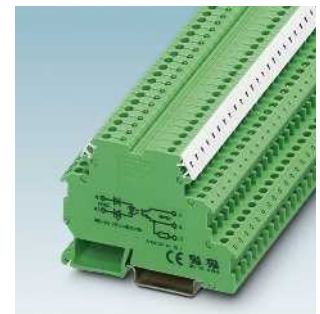

With solid-state relay
Page 440

Relay modules with force-guided contacts



Relay modules with force-guided contacts
Page 456

Relay modules for potentially explosive areas (Zone 2)



Relay modules for potentially explosive areas (Zone 2)
Page 458



RIF-4 for high-power relays
Page 324



Accessories
Page 330

PLC logic



Programmable logic relay system - PLC logic
Page 426

Special relay and solid-state relay modules



Relay terminal blocks with switch
Page 443



Interference-free relays and solid-state relays
Page 444



Relays for switching lamp loads
Page 447



Solid-state power relays with 400 V AC/3 A output
Page 448

Safety devices



Safety devices
See Catalog 6

Monitoring relays



Monitoring relays
Page 262

Time relays



Time relays
Page 276

Relay modules

Basics of relay technology

General information

Electromechanical relays are used as interface modules between the process I/O devices, on the one hand, and the open-loop/closed-loop control and signaling equipment, on the other, for level and power adjustment purposes.

Essentially, electromechanical relays can be divided into two main groups: monostable and bistable relays.

With monostable DC or AC relays, the contacts automatically return to the release state as soon as they are de-energized.

In the case of bistable relays, the contacts remain in their present switch position when the excitation current is switched off.

The documented relay data is based on test conditions and design criteria according to IEC 61810. Data may vary or be limited when mounting relays on DIN rail bases or on PCBs. Numerous parameters, such as:

- Operating time
- Load current
- Input voltage
- Dense mounting arrangement
- Heat dissipation into the environment and the layout for PCB applications ultimately determine the data for the overall arrangement.

The Phoenix Contact supply range features numerous ready-mounted relay combinations and base combinations, including some with additional input plug-in modules. These are tested under worst case conditions. The documented data then applies to the combinations.

Coil side

Input circuits and voltage types

There are various kinds of input circuit depending on the type of relay used and the nature of the control voltage.

If pure AC relays are used (AC input), the input circuit is generally nothing more than a visual switching status indicator.

Unless otherwise specified, the frequency of the control voltage is 50/60 Hz.

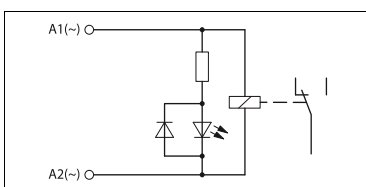

Basic structure of a relay with AC input

In the case of a pure DC input, the most important addition to the circuit is a freewheeling diode. This limits the voltages induced on the coil on circuit interruption to a value of approximately 0.7 V, which does not pose a danger to any connected control electronics.

As the freewheeling diode can only perform its required function if the polarity of the voltage connection is correct, a polarity protection diode is also integrated into the input circuit.

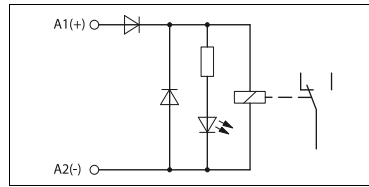

Basic structure of a relay with DC input

To allow DC or AC voltage operation, a bridge rectifier is connected in the input circuit. The diodes are simultaneously responsible for performing rectification, freewheeling, and polarity reversal protection functions. The interrupting voltage of the coil is limited to approximately 1.4 V.

To protect the input circuit against overvoltages, a varistor is also connected (depending on the type) upstream of the bridge rectifier.

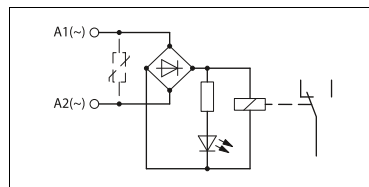

Basic structure of a relay with AC/DC input

Bistable latching relays with a double winding are only ever operated with DC voltage.

With these types of relay, there are three coil connections on the coil side. In addition to the common connection, there are separate connections for “setting” and “resetting”; these are controlled by short pulses only. As a result, the relays hardly heat up at all. Simultaneous control of both control inputs is not permitted.

A distinction is made between negative switching (M) and positive switching (P) types, depending on the polarity of the freewheeling and polarity protection diodes.

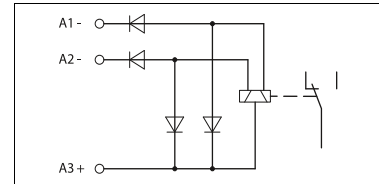

Basic structure of a bistable relay, negative switching type

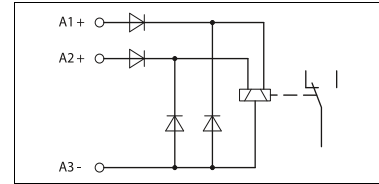

Basic structure of a bistable relay, positive switching type

Operating voltage range

The ambient temperature prevailing at the location of use has a major impact on certain relay operating parameters.

As the ambient temperature increases, the coil winding heats up, causing the operate and release voltages to rise. At the same time, the maximum permissible coil voltage decreases, which means that the usable working range becomes restricted as a result.

The diagram below illustrates how the operating voltage behaves as a function of the ambient temperature.

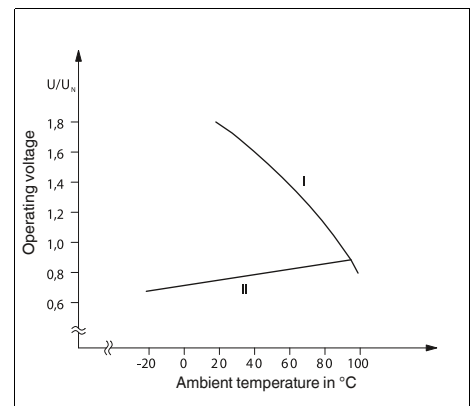

Basic curve of a relay operating voltage

- I: Maximum permissible voltage with 100% operating time (OT) and compliance with the coil temperature limit
- II: Minimum response voltage

Interference voltages and interference currents on the coil side

When inductive or capacitive interference voltages are coupled into the long supply lines of a relay, this can prevent the relay from operating safely.

If the coupled-in voltage exceeds the release voltage required by the IEC 61810-1 “relay standard”, in extreme cases the relay may fail to release. In the case of DC relays,

this release voltage is $\geq 0.05 \times U_N$ and for purely AC relays, it is $\geq 0.15 \times U_N$.

The same disturbances can occur when a relay with a low input power is controlled by an electronics module with an AC voltage output featuring an RC circuit. The typical leakage current from RC elements of this kind (generally in the region of several mA) provides sufficient control power to prevent the downstream relay from releasing or even enough power to excite it.

The disturbance level of any interference voltages that are present can be reduced by connecting an RC element in parallel to the relay coil. This measure also subjects the interference voltage to a capacitive load, causing it to collapse.

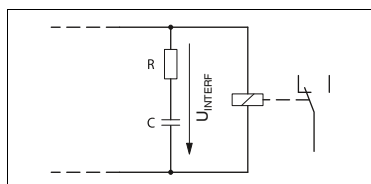

External RC interference suppressor to prevent interference voltage coupling

The following values are recommended for the purpose of dimensioning the RC element:

- R = 100 to 220 Ω
- C = 220 to 470 nF

The SO46 series has been developed to provide even higher levels of immunity to interference. These products already contain an integrated RCZ filter. See, for example, PLC...SO46.

Contact side, contact materials

Given the wide variety of potential applications in the different industrial sectors, the relays used must be matched to the various tasks that need to be performed by selecting the right kind of contact material.

The voltage, current, and power values play an important role when determining the suitability of contact materials. Other criteria include:

- Contact resistance
- Erosion resistance
- Material migration
- Welding tendency
- Chemical influences

In this way, the various contact materials (generally noble metal alloys) can be matched to the relevant areas of application.

The adjacent table provides details of some of the key materials.

Contact material	Typical properties	Typical applications	Guide values for the area of application*
Gold Au	Largely insensitive to industrial atmospheres, low and constant contact resistances in the range of small switching capacities with nickel (AuNi) or silver (AuAg) alloys.	Dry measuring and switching circuits, control inputs	$\mu\text{A} \dots 0.2 \text{ A}$ $\mu\text{V} \dots 30 \text{ V}$
Silver Ag	High electrical conductivity, sensitive to sulfur, therefore often gold-flashed (approximately, 0.2 μm) as protection; nickel (AgNi) or copper (AgCu) alloys increase the mechanical resistance and erosion resistance and reduce the welding tendency.	Universal, suitable for medium loads; nickel alloys (AgNi 0.15) for DC circuits with medium to large loads	$\geq 12 \text{ V}$ $\geq 10 \text{ mA}$
Silver, hard gold-plated Ag + Au	Properties similar to gold Au, when switching loads $> 30 \text{ V}/0.2 \text{ A}$, the hard gold plating (5 - 10 μm) is destroyed and the values and properties of the Ag contact are applicable. However, a reduction in the service life is then to be expected.	Suitable for control inputs and other small loads.	$\geq 100 \text{ mV}$ $\geq 1 \text{ mA}$
Tungsten W	Highest melting point, very high erosion resistance, greater contact resistances, very low welding tendency, susceptible to corrosion, often used as lead contact.	Loads with very high inrush currents, e.g., glow lamps, fluorescent lamps.	$\geq 60 \text{ V}$ $\geq 1 \text{ A}$
Silver nickel AgNi	High erosion resistance, low welding tendency, higher contact resistances than with pure silver.	Universal, suitable for medium to high loads, DC circuits, and inductive loads.	$\geq 12 \text{ V}$ $\geq 10 \text{ mA}$
Silver nickel AgNi + Au	Properties similar to gold Au, when switching loads $> 30 \text{ V}/0.2 \text{ A}$, the hard gold plating (5 - 10 μm) is destroyed and the values and properties of the AgNi contact are applicable. However, a reduction in the service life is then to be expected.	Suitable for control inputs and other small loads.	$\geq 100 \text{ mV}$ $\geq 1 \text{ mA}$
Silver tin oxide AgSnO	Low welding tendency, very high erosion resistance for high switching capacities, low material migration	Application depends heavily on the relay type, switching circuits with high make and break loads, e.g., glow lamps and fluorescent lamps, AC and DC circuits. Due to different alloys and production procedures, partly also suitable for smaller loads.	$\geq 12 \text{ V}$ $\geq 100 \text{ mA}$ ($\geq 10 \text{ mA}$)
Silver tin oxide, hard gold-plated AgSnO + Au	Properties similar to gold Au, when switching loads $> 30 \text{ V}/0.2 \text{ A}$ the hard gold plating (5 - 10 μm) is destroyed and the values and properties of the AgSnO contact are applicable. However, a reduction in the service life is then to be expected.	Suitable for control inputs and other small loads.	$\geq 100 \text{ mV}$ $\geq 1 \text{ mA}$

* Values depend on the relay used and on further operating conditions.

Contact protection circuit

Every electrical consumer constitutes a mixed load with ohmic, capacitive, and inductive components.

When these loads are switched, the switching contact is in turn subjected to a load, to either a lesser or greater extent. This load can be reduced by including a suitable contact protection circuit.

In view of the fact that consumers with a large inductive component are predominantly used in practice (e.g., contactors, solenoid valves, motors, etc.), these application scenarios are worth considering in more detail.

On interruption, voltage peaks with values of up to several thousand volts occur due to the energy stored in the coil.

These high voltages cause an electric arc on the switching contact which can destroy the contact due to material vaporization and material migration. The electrical service life is reduced considerably as a result. In extreme cases, the relay may fail in the very first switching cycle with DC voltage and a static electric arc.

A protective circuit must be used to suppress the formation of an electric arc. With optimum dimensioning, almost the same number of switching cycles can be achieved as with an ohmic load.

Relay modules

Basics of relay technology

In principle, there are a number of possible ways of achieving an effective circuit:

1. Wiring the contact
2. Wiring the consumer
3. Combination of both wiring methods

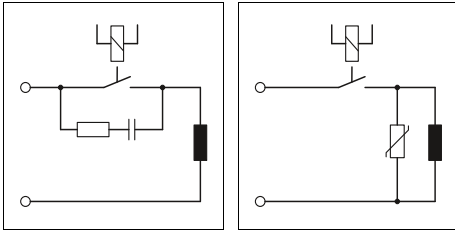

Wiring the contact

Wiring the inductive consumer

In principle, protective measures should intervene directly at the source of the interference.

Wiring a consumer should therefore be given priority over wiring the contact.

The following points are advantageous for the consumer circuit (image on right):

1. The circuit is only loaded with the induction voltage during interruption. By contrast, the sum of the operating voltage and the induction voltage is applied to the contact circuit.
2. When the contact is open, the load is electrically isolated from the operating voltage.
3. It is not possible for the load to be activated or to “stick” due to undesired operating currents, e.g., from RC elements.
4. Cut-off peaks of the load cannot be coupled into parallel control lines.

Nowadays, solenoid valves are usually connected using valve connectors that are also supplied with LEDs and components that limit the induction voltage. Valve connectors with an RC element, varistor or Zener diode often do not quench the arc and only serve to comply with legislation governing EMC. Only valve connectors with an integrated 1N4007 freewheeling diode quench the arc quickly and safely, thereby increasing the service life of the relay by a factor of 5 to 10. Valve connectors with LED, integrated 1N4007, and free cable end can be supplied on request as part of the SAC range.

Load wiring	Additional dropout delay	Defined induction voltage limitation	Effective bipolar attenuation	Advantages and disadvantages
Diode 	Large	Yes (U_D)	No	Advantages: <ul style="list-style-type: none"> • Good effect in terms of extending the service life of the contacts • Easy implementation • Inexpensive • Reliable • Dimensioning not critical • Low induction voltage Disadvantages: <ul style="list-style-type: none"> • Attenuation only via load resistor • Long dropout delay
Series connection diode/Zener diode 	Medium to small	Yes (U_{ZD})	No	Advantages: <ul style="list-style-type: none"> • Dimensioning not critical Disadvantages: <ul style="list-style-type: none"> • Attenuation only above U_{ZD} • Minimal effect in terms of extending the service life of the contacts
Suppressor diode 	Medium to small	Yes (U_{ZD})	Yes	Advantages: <ul style="list-style-type: none"> • Inexpensive • Dimensioning not critical • Limitation of positive peaks • Suitable for AC voltage Disadvantages: <ul style="list-style-type: none"> • Attenuation only above U_{ZD} • Minimal effect in terms of extending the service life of the contacts
Varistor 	Medium to small	Yes (U_{VDR})	Yes	Advantages: <ul style="list-style-type: none"> • High energy absorption • Dimensioning not critical • Suitable for AC voltage Disadvantages: <ul style="list-style-type: none"> • Attenuation only above U_{VDR} • Minimal effect in terms of extending the service life of the contacts
R/C combination 	Medium to small	No	Yes	Advantages: <ul style="list-style-type: none"> • HF attenuation due to energy storage • Suitable for AC voltage • Level-independent attenuation Disadvantages: <ul style="list-style-type: none"> • Precise dimensioning required • High inrush current surge • Minimal effect in terms of extending the service life of the contacts

Switching small loads

Small loads have to be processed mainly in applications where signals have to be forwarded to control inputs (e.g., of a PLC).

With these loads, no switching sparks (electric arcs) occur on the contacts in the small load range.

In addition to the constant cleaning effect due to contact friction, this switching spark assumes the function of penetrating non-conductive contamination layers that are formed on the contact surfaces of power contacts.

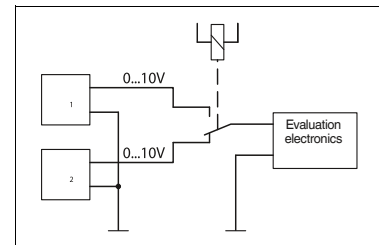

Application example: Measurement point changeover

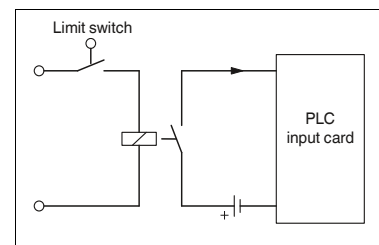

Application example: PLC input signal

These contamination layers are usually oxidation or sulfidation products of the contact materials silver (Ag) or silver alloys such as silver nickel (AgNi) or silver tin oxide (AgSnO). As a result, the contact resistance may rise so considerably within a short time that reliable switching is no longer possible in the case of small loads.

Due to these properties, the power contact materials mentioned are not suitable for small load applications.

Gold (Au) has become accepted as the contact material of choice for these areas of application mainly on account of its low and constant contact resistances even with small loads and its insensitivity to sulfurous atmospheres.

For the smallest of loads and even greater contact reliability, double contact relays with gold contacts are used.

The slotted contact spring in this design provides two parallel contact points with even lower contact resistances and considerably higher contact reliability.

Switching large loads

A few important points also need to be considered with regard to switching operations in the large load range that involve power contacts made of either silver (Ag) or silver tin oxide (AgSnO).

A basic distinction must be made between switching DC and AC loads.

Switching large AC loads

When switching large AC loads, the relay can be operated up to the corresponding maximum values for switching voltage, current, and power. The electric arc that occurs during interruption depends on the current, voltage, and phase relation. This cut-off arc usually disappears automatically the next time the load current passes through zero.

In applications with an inductive load, an effective protective circuit must be provided, otherwise the service life of the system will be reduced considerably.

Switching large DC loads

Conventional switching relays can only switch off relatively small direct currents (which contrasts with their ability to switch off the maximum permissible AC current), since there is no zero crossing to extinguish the arc automatically. This maximum DC value is also dependent to a large extent on the switching voltage and is determined, among other things, by constructional features such as contact spacing and contact opening speed.

The corresponding current and voltage values are documented by relay manufacturers in electric arc or load limit curves.

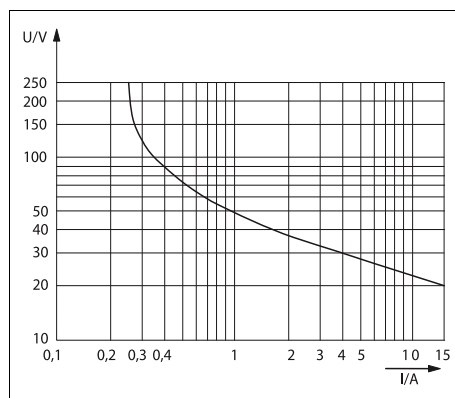

Example of a load limit curve (dependent on the type)

A non-attenuated inductive DC load further reduces the values given for switchable currents. The energy stored in the inductance can cause an electric arc to occur, which forwards the current through the open contacts.

With an effective contact protection circuit, preferably type 1N4007 freewheeling diodes, the service life can be increased by a factor of 5 to 10 compared with unprotected or poorly protected inductive loads (see also “Contact protection circuit” section).

If higher DC loads than those documented are to be switched or if the electrical service life is to be increased, several contacts of a relay can be connected in series. See, for example, REL-IR... industrial relays.

Alternatively, solid-state relays with DC voltage output can also be used.

Switching lamps and capacitive loads

Regardless of the type of voltage, all kinds of lamps and loads with a capacitive component impose extreme requirements on the switching contacts. The moment it is switched on, in other words precisely in the dynamic chattering phase of the relay, extremely powerful current peaks occur.

These are often in the region of several tens of amps, and not infrequently are known to exceed 100 A, which results in welding of the contact. This can be remedied by using specially optimized “lamp load relays” that can cope with these inrush peaks. See, for example, PLC...IC type.

Switching capacity according to utilization categories AC15 and DC13 (IEC 60947)

In practice, both the maximum interrupting rating for AC loads and the DC interruption values taken from the load limit curves provide only a rough guide for the choice of relay. In reality, this is insufficient, since real loads in the vast majority of industrial applications have inductive or capacitive components and the wiring of the loads can be totally different. As already described, this sometimes leads to considerable variations in terms of service life.

The IEC 60947 contactor standard seeks to avoid these disadvantages by dividing the loads into various utilization categories (DC13, AC15, etc.). This standard is also partly applied to relays. However, users must be aware of the fact that these values are only applicable in practice to a limited extent as well, since all DC13 and AC15 test loads are highly inductive and are also operated without any protective circuit at all (see “Contact protection circuit” section). Moreover, the switching capacity test according to IEC 60947 only requires 6060 switching cycles to be performed by way of a minimum requirement.

A much more reliable way to determine the switching capacity and the anticipated service life is to refer to the specific application data. Using a comprehensive data bank, the service life can be accurately estimated for most applications and, if necessary, suggestions for improvement can be made. In the case of critical applications, the user is advised to gather service life information based on empirical data.

Basics of solid-state relay technology

Control side

Solid-state relays for various voltage and power levels are available from Phoenix Contact for use as interface modules designed to match process I/O devices to control, signaling, and regulating devices. The solid-state relay element which is actually located in the module is limited to one defined voltage range by virtue of its design. The current consumption on the input side fluctuates depending on the circuit architecture and voltage level.

To accommodate all voltages required for industrial applications between 5 V and 230 V, an input circuit is provided. The inputs for DC voltage and AC voltage must always be differentiated.

DC input

Adjustments are made in accordance with the various voltage levels by adding electronics which have been specially adapted to the desired voltage range. In the case of most modules, a polarity protection diode provides reliable protection against destruction in the event of a control voltage being connected incorrectly. Specially coordinated filters reliably suppress possible high-frequency noise emissions.

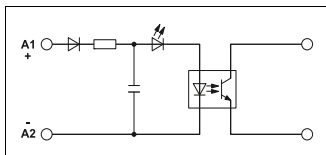

Figure 1: Block diagram for DC input

AC input

The solid-state relay element requires a stable control voltage to ensure reliable operation. In the case of the AC input, this is achieved by connecting a rectifier and filter capacitor upstream. The rectification is followed, in principle, by the same circuit architecture as the DC input.

The switching frequency always lies below half the mains frequency. Due to the filter capacitor, a higher switching frequency

cannot be achieved. This results in continuous through-switching.

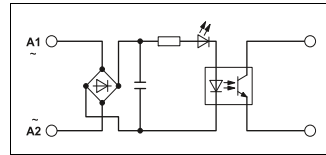

Figure 2: Block diagram for AC input

Load side

Depending on the application and the type of load, the solid-state relay output must meet various requirements. The following are crucial:

- Power amplification
- Matching the switching voltage and the switching current (AC/DC)
- Short-circuit protection

For these different applications, the solid-state relay element must also be processed using additional electronics on the output side.

DC output

In order to achieve the necessary output power, the solid-state relay element is supplemented by one or more semiconductor components.

The on-site user should nevertheless simply regard the connection terminal blocks of the output as conventional switch connections. Observing the specified polarity is the only essential requirement.

For practical reasons, the following criteria should be taken into account when selecting a suitable solid-state relay:

1. Operating voltage range (e.g., 12 ... 60 V DC)
This determines the minimum or maximum voltage to be switched. The lower value must be observed in order to ensure reliable operation. In order to protect the output transistor, the upper value must not be exceeded.
2. Maximum continuous current (e.g., 1 A)
This value indicates the maximum continuous current. If this value is exceeded continuously, the output semiconductor will be destroyed. The dependence of the output current on the ambient temperature of the solid-state relay should also be taken into consideration. A derating curve is therefore generally specified for solid-

state power relays. This shows the maximum load current as a function of the ambient temperature.

3. Output circuit

The 2-conductor output is similar to a mechanical contact. Only the polarity of the connections is specified and must be observed.

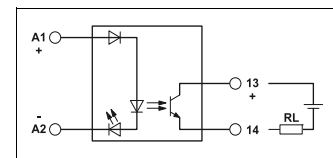

Figure 3: 2-conductor output

The 3-conductor output is non-isolated and requires both potentials from the voltage source on the output side to be connected if it is to operate reliably.

When switched off, a permanent reference to ground (negative potential) is established. In addition, this output circuit offers the advantage of an almost constant internal resistance.

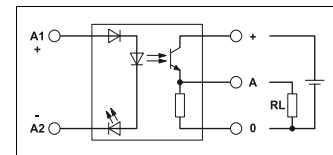

Figure 4: 3-conductor output

AC output

In order to control the switching and control devices for AC voltage, a semiconductor for AC voltage (TRIAC or thyristor) is connected downstream of the solid-state relay element.

As with the DC output, it is particularly important to consider the maximum operating voltage range and the maximum continuous load current as a function of the ambient temperature.

Basics of solid-state relay technology

In addition, the maximum peak reverse voltage of the TRIAC (e.g., 600 V) is crucial with AC outputs. This must not be exceeded even in the case of voltage fluctuations or interference voltage peaks in order to prevent destruction. That is why the AC outputs of all solid-state relays from Phoenix Contact have an internal RC protective circuit to protect against interference voltage peaks.

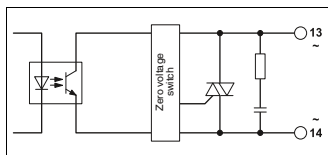

Figure 5: Basic circuit diagram of AC output

Protective circuits

The moment inductive loads (contactors, solenoid valves, motors) are switched off, surge voltages occur and these can reach very high amplitudes. Electronic components and switching elements are particularly susceptible to these. A protective circuit should therefore always be provided to prevent destruction.

A parallel connection to the load effectively reduces the switching surge voltage to a harmless level. Depending on the solid-state relay output and load type,

- a freewheeling diode/suppressor diode (DC only),
- a varistor (AC and DC)
- or an RC element (AC only)

can provide the necessary protection.

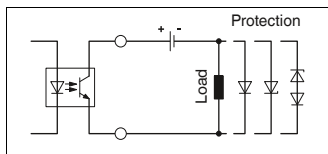

Figure 6: Protective circuit with DC voltage output

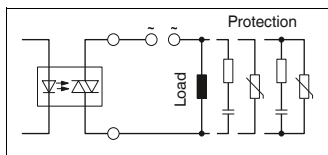

Figure 7: Protective circuit with AC voltage output

Application notes

Input solid-state relays acting in the direction from the I/O devices to the controller (signaling, controlling, monitoring)

Plug-in version:
– PLC-O...

Modular version:
– DEK-OE...
– EMG 10-OE...
– SIM-EI...
– OPT...

e.g., load protection monitoring (DC contactor)

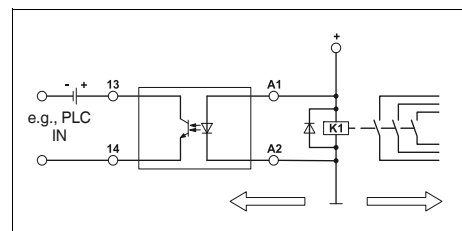

e.g., load protection monitoring (AC contactor)

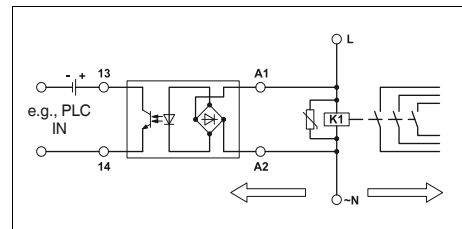

e.g., position indication with limit stop contact or initiator

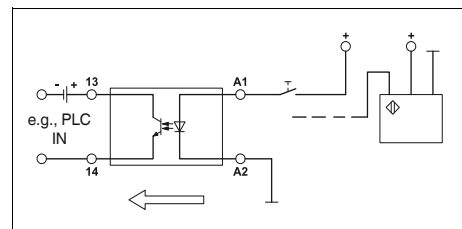

e.g., switching the contactor, solenoid valve or motor (DC load)

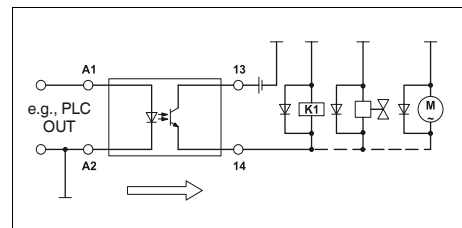

e.g., switching the contactor, solenoid valve or motor (AC load)

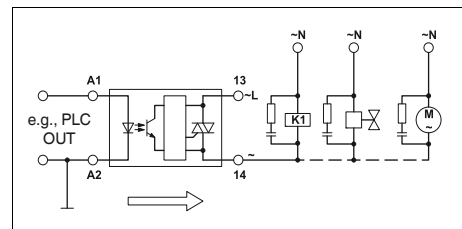

Remarks:

- 1) Ground (negative) potential from the input and output of the solid-state relay must not be connected.
- 2) DC loads must be provided with an effective protective circuit (e.g., diode).
- 3) AC loads must be protected with a varistor or an RC element.

Output (power) solid-state relays acting in the direction from the controller to the I/O devices (switching, amplifying, controlling)

Plug-in version:
– PLC-O...

Modular version:
– DEK-OV...
– EMG 10-OV
– EMG 12-OV
– EMG 17-OV
– OV...
– OPT...

Relay modules

Sensor/actuator configuration aids and handling of interference signals

Configuration aid for connecting sensors and actuators

Electromechanical relays or solid-state relays are used as the coupling element between the controller and the sensors or actuators in the field. This interface ensures appropriate signal conditioning with respect to current and voltage between the controller and field level.

Conventional connection of actuators

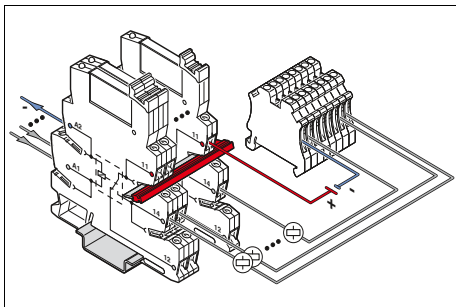

If actuators such as solenoid valves are connected to the controller via a universal relay with changeover contact, an additional terminal block strip must be used for the common load return line. The positive potential of the loads is applied to connection terminal block 11 (changeover contact) at the relay modules. This can be distributed over all relay modules using plug-in bridges. This means that direct connection of the potential to only one relay is necessary. The loads are connected to connection terminal block 14 (N/O contact). The negative potential required is supplied at a terminal block. This is then distributed to further terminal blocks by means of plug-in bridges. However, load return lines for the individual actuators are applied to every terminal block. This results in a common load return line potential for all actuators via the additional terminal block.

Because of increased space requirements and additional wiring to the terminal block, the use of additional terminal blocks for potential distribution is extremely time-consuming.

Easy wiring of actuators

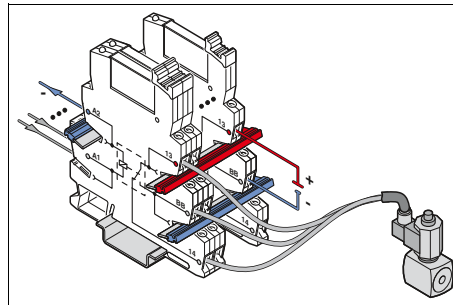

The PLC...ACT relay modules enable fast and easy connection of actuators. The positive potential of the loads is applied to connection terminal block 13. This can be distributed over all relay modules using plug-in bridges. This only makes direct connection to one module necessary. The actuators are connected to contact 14 (N/O contact). In the case of PLC...ACT relay modules, an N/C contact is not required. Instead, the BB connection serves as an option for connecting the load return line. Here the common negative potential is supplied and distributed by means of plug-in bridges. The terminal block for conventional wiring is not necessary due to the direct connection of the load return line potential to the relay module. This means that no additional space is required in the control cabinet and simpler wiring minimizes the risk of error.

Conventional connection of sensors

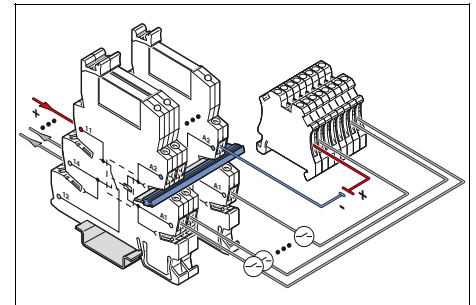

If sensors such as proximity switches are connected via a universal relay to a controller with a changeover contact, an additional terminal block strip must be used for the common sensor supply voltage. It is also important to note that either the wiring in the control cabinet must be implemented the other way round since control of the relay now takes place from the field level and not via the controller, or the relay module must be installed into the control cabinet rotated at 180°. The negative potential of the sensors is applied at connection terminal block A2 on the relay module. This can be distributed over all relay modules using plug-in bridges. This means that direct connection to only one relay is necessary. The sensors are connected to connection terminal block A1. The necessary positive potential is supplied to a terminal block and distributed to further terminal blocks by means of plug-in bridges. However, the supply for the individual sensors is applied to every terminal block. This results in a common supply signal for all sensors via the additional terminal blocks.

Because of increased space requirements and additional wiring to the terminal block, the use of additional terminal blocks for potential distribution is extremely time-consuming.

Configuration aid for handling interference signals

According to IEC 61810-1, the standard release voltage of a relay is 5% of the nominal voltage for DC coils and 15% for AC coils. That means that a relay with a nominal voltage of 230 V AC is only switched off when the control voltage is $\leq 0.15 \times 230 \text{ V AC} = 34.5 \text{ V AC}$. If interference signals occur on the control side of a relay that are greater than the release voltage, defined switch-off is no longer possible. In the worst case, the interference is large enough to energize the relay. The application is still switched on although no signal is issued by the controller. There can be various reasons for this.

Easy wiring of sensors

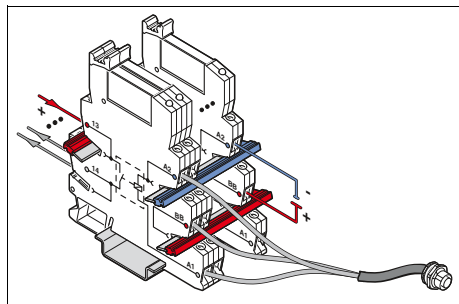

Sensors can be efficiently coupled with the controller with the PLC...SEN relay modules. The input and output side on the module are already interchanged so that the signal direction from the field to the controller can be ideally represented. Therefore, three connection terminal blocks (A1, A2, and BB) are located on the control side of the relay. The common negative potential of the sensors is connected to A2 and distributed to further relay modules by means of plug-in bridges. The sensors are connected directly to the A1 connections. Connection BB is used for the common supply potential of the sensors. The potential is distributed to all connected sensors by means of the plug-in bridges. However, only connections 13 and 14 for the N/O contact are located on the contact side. Signal feedback to the controller takes place via this. The terminal block for conventional wiring is not necessary due to direct connection of the sensor supply voltage to the relay module. This means that no additional space is required in the control cabinet and simpler wiring minimizes the risk of error.

Leakage current with AC voltage output card

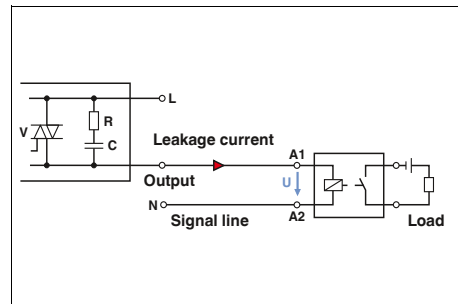

Leakage current on the signal line occurs if control of a relay takes place via an output card with AC voltage. This is caused by the RC wiring of the AC voltage output. Typically, the leakage current has a control power that is large enough not to switch off the relay reliably.

Coupling of interference signals from parallel lines

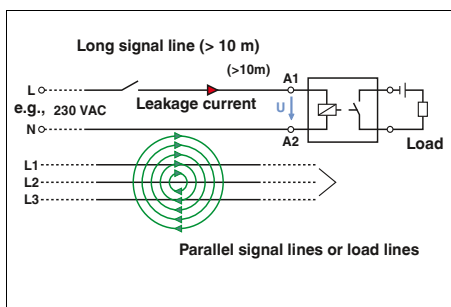

If the control lines to the relay are very long, interference can occur from parallel-running cables. These influence the actual control line and couple the signals to it. This interference voltage can be measured on the control side, even if no signal is issued by the controller.

Safe shutdown even with interference signals

The PLC...SO46 series is equipped with RCZ wiring in the base. The release voltage of the relay is increased by this circuit of resistor, capacitor, and Zener diode so that the relay is resistant to interference voltages. In the case of a 230 V AC relay, the standard release voltage is 34.5 V AC. The PLC...230UC...SO46 modules have a release voltage of 80 V AC. This enables the relay to switch off reliably at interference voltages of $\leq 80 \text{ V AC}$. The PLC...SO46 bases are also available with further voltages. They can be fitted with both electromechanical relays or solid-state relays. Screw connection or Push-in connection is available as the connection technology.

Relay modules

Industrial relay system - RIFLINE complete

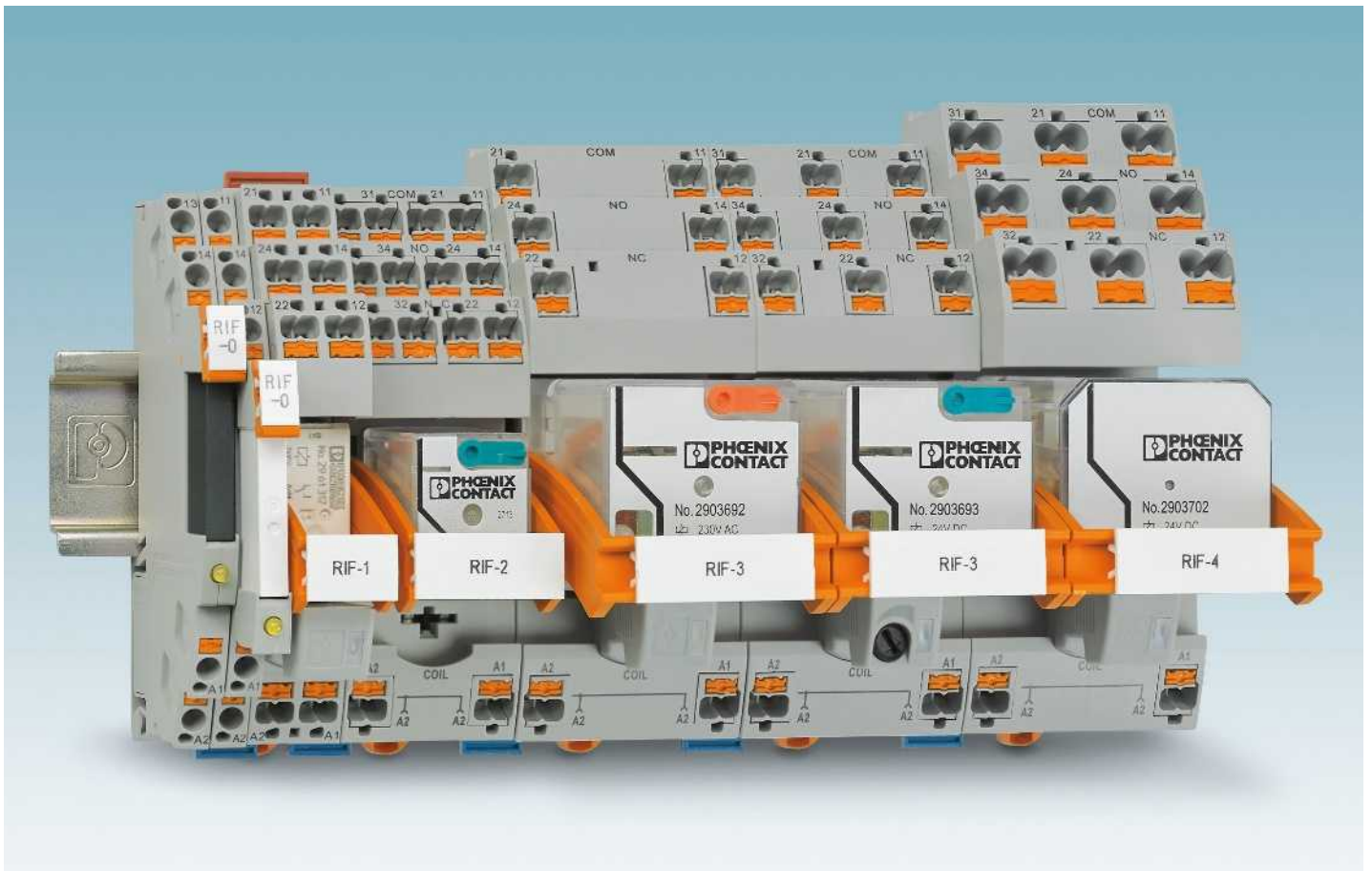

RIFLINE complete is an inexpensive relay system with various accessories. It consists of DIN rail bases, electromechanical or solid-state relays, plug-in interference suppression modules, marking material, and bridging material. The range of accessories is rounded off with a timer module. This is used to transform a basic relay into a time relay with three different functions.

The RIFLINE complete relay range consists of seven different base versions from RIF-0 to RIF-4 – these range from one N/O contact up to four PDT contacts. The field of application of this product group ranges from coupling relay applications with switching currents of one milliamp to replacement for miniature contactors with currents up to 16 A.

The relay bases feature Push-in or screw connection technology. Push-in connection technology enables quick and tool-free conductor contacting. The RIF-1 to RIF-4 bases offer double the contact options on both the input and output side.

On the input side of all bases, the negative potential (A2) can be bridged – regardless of the base size. On the output side, the grouped contact (11) can be bridged within the RIF-0 base version. This connection can also be bridged within the RIF-1 base size.

To offer diverse marking options, the engagement lever can be fitted with a zack marker strip. In addition, marker carriers

can be mounted on the bases so that additional marking surfaces are available.

RIFLINE complete can be extended using many elements from the CLIPLINE complete accessories range. This includes marking material, bridges, and test adapters.

To make ordering and management easier, RIFLINE complete modules are provided in the most popular voltages as complete modules with relay and interference suppression module. For individual assembly, tailored to the requirements of the application, additional voltage levels are offered in the modular system.

**RIF-0**

The 6.2 mm narrow RIF-0 base series is suitable for a 1-PDT relay. Switching currents up to 6 A are implemented here. Two base versions are available: 1 N/O contact and 1 changeover contact. RIF-0 is therefore a good choice for all coupling applications.

**RIF-1**

The 16 mm narrow RIF-1 base series is suitable for a 2-PDT relay. Currents up to 13 A can be switched when using the FBS 2-8 plug-in bridge. This relay is ideal for power switching and signal duplication.

**RIF-2**

The 31 mm wide RIF-2 base series is designed for industrial relays with up to 4 contacts. Currents up to 12 A are no problem for these bases. This relay is ideal for applications that require power and signal multiplication.

**RIF-3**

The 40 mm wide RIF-3 base series is designed for octal relays with up to 3 contacts. Switching currents up to 10 A are implemented here. Two base versions are available: 2 changeover contacts and 3 changeover contacts. RIF-3 bases are ideal for all applications that require power and signal multiplication.

**RIF-4**

The 43 mm wide RIF-4 base series is designed for power relays with up to 3 contacts. Currents up to 16 A can be switched. RIF-4 bases are a good choice for applications that require power and signal multiplication, e.g., in miniature contactor applications.

**Accessories**

A wide range of accessories are available for the RIFLINE complete relay system that round off the range. These include bridges, professional marking material, function modules, test plugs, and end brackets.

Relay modules

Industrial relay system - RIFLINE complete

Modular RIF-0 relay base

Relay base for assembly with miniature power relays or solid-state relays with a nominal voltage of 12 to 24 V DC.

The advantages:

- Integrated freewheeling diode for input circuit and interference suppression circuit
- LED for status display
- Safe isolation according to DIN EN 50178 between coil and contact
- Professional marking material
- Holders for test plugs
- Professional bridging of adjacent modules saves wiring time (A2 and 11/13)
- FBS 2-6 plug-in bridges for the input and output side

Notes:
Type of insulating housing: Polyamide PA, non-reinforced, color: gray.
For further marking systems and mounting material, see Catalog 3.
When mounting relays on a DIN rail base or PCB, data may be limited, especially with regard to the limiting continuous current and/or ambient temperature range. See "General" section in "Basics of relay technology" on page 286.

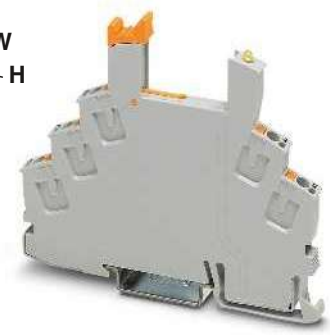

1-PDT relay base with Push-in connection technology



Technical data

250 V AC/DC (Contact side)
max. 8 A (Depends on application/assembly)

Nominal voltage U_N
Nominal current at U_N

General data

Ambient temperature (operation)

-40 °C ... 85 °C (Depends on application/assembly)

Connection data solid/stranded/AWG

0.14 ... 1.5 mm² / 0.14 ... 1.5 mm² / 26 - 16

Maximum tightening torque

-

Dimensions

Width

6.2 mm

Depth

78 mm

Height

93 mm

Ordering data

Description	Type	Order No.	Pcs./ Pkt.
RIF-0 relay base , PDT version, safe isolation I/O with Push-in connection	RIF-0-BPT/21	2900958	10
RIF-0 relay base , N/O contact version, safe isolation I/O with Push-in connection			
RIF-0 relay base , PDT version, safe isolation I/O with screw connection			
RIF-0 relay base , N/O contact version, safe isolation I/O with screw connection			
RIF-0 relay base , negative switching, PDT version, safe isolation I/O with Push-in connection	RIF-0-BPT-M/ 21	2907468	10

Accessories

Plug-in bridge			
2-pos. red, 24 A	FBSR 2-6	3033715	50
2-pos. red, 32 A	FBS 2-6	3030336	50
2-pos. blue, 32 A	FBS 2-6 BU	3036932	50
2-pos. gray, 32 A	FBS 2-6 GY	3032237	50
3-pos. red, 24 A	FBSR 3-6	3001594	50
4-pos. red, 24 A	FBSR 4-6	3001595	50
5-pos. red, 24 A	FBSR 5-6	3001596	50
5-pos. red, 32 A	FBS 5-6	3030349	50
10-pos. red, 32 A	FBS 10-6	3030271	10
20-pos. red, 32 A	FBS 20-6	3030365	10
50-pos. red, 32 A	FBS 50-6	3032224	10
End bracket , for snapping onto NS 35, 9.5 mm wide, can be marked with ZB 6, ZB 8/27, KLM...	CLIPFIX 35	3022218	50
Test plug , consisting of:	MPS-MT	0201744	10
Metal part for 2.3 mm Ø socket hole and	MPS-IH RD	0201676	10
	MPS-IH WH	0201663	10
Insulating sleeve , for MPS metal part	MPS-IH BU	0201689	10
	MPS-IH YE	0201692	10
	MPS-IH GN	0201702	10
	MPS-IH GY	0201728	10
	MPS-IH BK	0201731	10
Zack marker strip , unprinted, 10-section: each pack contains enough to mark 100 terminal blocks	ZB 6:UNBEDRUCKT	1051003	10
10-section			

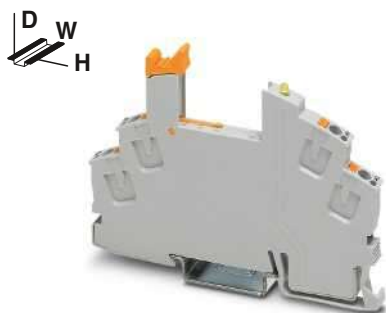

1-N/O relay base for miniature power relay

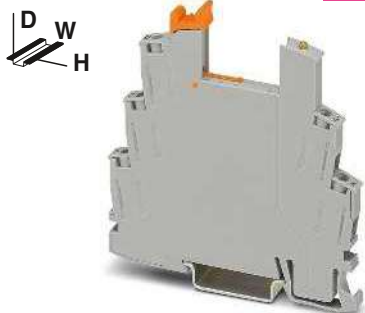

1-PDT relay base with screw connection technology

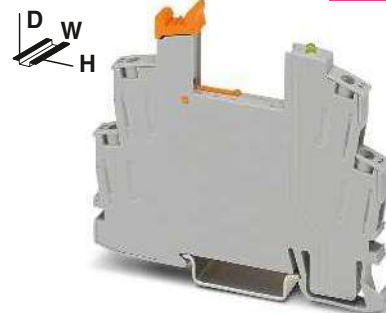

1-N/O relay base with screw connection technology



Technical data	
250 V AC/DC (Contact side) max. 8 A (Depends on application/assembly)	
-40 °C ... 85 °C (Depends on application/assembly)	
0.14 ... 1.5 mm ² / 0.14 ... 1.5 mm ² / 26 - 16	
-	
6.2 mm	
66 mm	
93 mm	

Technical data	
250 V AC/DC (Contact side) max. 8 A (Depends on application/assembly)	
-40 °C ... 85 °C (Depends on application/assembly)	
0.5 ... 4 mm ² / 0.5 ... 2.5 mm ² / 20 - 12	
0.5 Nm	
6.2 mm	
82 mm	
84 mm	

Technical data	
250 V AC/DC (Contact side) max. 8 A (Depends on application/assembly)	
-40 °C ... 85 °C (Depends on application/assembly)	
0.5 ... 4 mm ² / 0.5 ... 2.5 mm ² / 20 - 12	
0.5 Nm	
6.2 mm	
68 mm	
84 mm	

Ordering data		
Type	Order No.	Pcs./ Pkt.
RIF-0-BPT/1	2901873	10

Ordering data		
Type	Order No.	Pcs./ Pkt.
RIF-0-BSC/21	2900957	10

Ordering data		
Type	Order No.	Pcs./ Pkt.
RIF-0-BSC/ 1	2901872	10

Accessories		
FBSR 2-6	3033715	50
FBS 2-6	3030336	50
FBS 2-6 BU	3036932	50
FBS 2-6 GY	3032237	50
FBSR 3-6	3001594	50
FBSR 4-6	3001595	50
FBSR 5-6	3001596	50
FBS 5-6	3030349	50
FBS 10-6	3030271	10
FBS 20-6	3030365	10
FBS 50-6	3032224	10
CLIPFIX 35	3022218	50
MPS-MT	0201744	10
MPS-IH RD	0201676	10
MPS-IH WH	0201663	10
MPS-IH BU	0201689	10
MPS-IH YE	0201692	10
MPS-IH GN	0201702	10
MPS-IH GY	0201728	10
MPS-IH BK	0201731	10
ZB 6:UNBEDRUCKT	1051003	10

Accessories		
FBSR 2-6	3033715	50
FBS 2-6	3030336	50
FBS 2-6 BU	3036932	50
FBS 2-6 GY	3032237	50
FBSR 3-6	3001594	50
FBSR 4-6	3001595	50
FBSR 5-6	3001596	50
FBS 5-6	3030349	50
FBS 10-6	3030271	10
FBS 20-6	3030365	10
FBS 50-6	3032224	10
CLIPFIX 35	3022218	50
MPS-MT	0201744	10
MPS-IH RD	0201676	10
MPS-IH WH	0201663	10
MPS-IH BU	0201689	10
MPS-IH YE	0201692	10
MPS-IH GN	0201702	10
MPS-IH GY	0201728	10
MPS-IH BK	0201731	10
ZB 6:UNBEDRUCKT	1051003	10

Accessories		
FBSR 2-6	3033715	50
FBS 2-6	3030336	50
FBS 2-6 BU	3036932	50
FBS 2-6 GY	3032237	50
FBSR 3-6	3001594	50
FBSR 4-6	3001595	50
FBSR 5-6	3001596	50
FBS 5-6	3030349	50
FBS 10-6	3030271	10
FBS 20-6	3030365	10
FBS 50-6	3032224	10
CLIPFIX 35	3022218	50
MPS-MT	0201744	10
MPS-IH RD	0201676	10
MPS-IH WH	0201663	10
MPS-IH BU	0201689	10
MPS-IH YE	0201692	10
MPS-IH GN	0201702	10
MPS-IH GY	0201728	10
MPS-IH BK	0201731	10
ZB 6:UNBEDRUCKT	1051003	10

Relay modules

Industrial relay system - RIFLINE complete

Plug-in miniature power relays

new

Plug-in 1-PDT relays suitable for RIF-0 and PLC-INTERFACE relay bases.

The advantages:

- Power contacts up to 6 A
- Multi-layer gold contact or power contact
- High degree of protection, RT III (wash-proof), or RT II for 1-PDT relay with manual operation
- Safe isolation according to DIN EN 50178 between coil and contact
- Can be soldered on PCB



1-PDT relay, max. 6 A



1-PDT relay with manual operation, max. 6 A

Notes:
 If the specified maximum values for multi-layer contact relays are exceeded, the gold plating is destroyed. The maximum values of the power contact relay are then valid. This can result in a shorter service life than with a pure power contact.
 For dimensional drawings and perforations for assembly, see page 398
 When mounting relays on a DIN rail base or PCB, data may be limited, especially with regard to the limiting continuous current and/or ambient temperature range. See "General" section in "Basics of relay technology" on page 286.

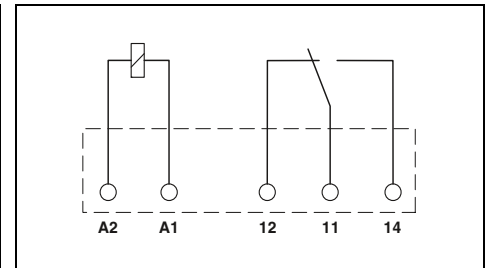
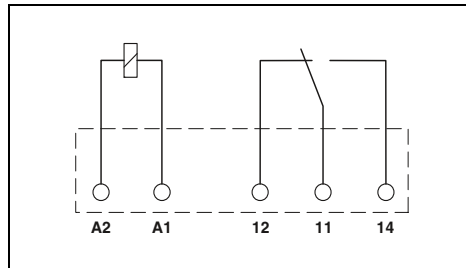

Input data	
Permissible range (with reference to U_N)	
Typical input current at U_N	[mA]
Typical response time at U_N	[ms]
Typical release time at U_N	[ms]
Output data	
Contact type	
Contact material	
Max. switching voltage	
Minimum switching voltage	
Limiting continuous current	
Maximum switch-on current	
Minimum switching current	
General data	
Test voltage (winding / contact)	
Ambient temperature (operation)	
Nominal operating mode	
Mechanical service life	
Standards/regulations	
Mounting position/mounting	
Dimensions	W / H / D

Technical data	
①	②
see diagram	
14	7
5	5
2.5	2.5
1 PDT	1 PDT
AgSnO	AgSnO, hard gold-plated
250 V AC/DC	30 V AC / 36 V DC
5 V (at 100 mA)	100 mV (at 10 mA)
6 A	50 mA
10 A (4 s)	50 mA
10 mA (at 12 V)	1 mA (at 24 V)
4 kV AC (50 Hz, 1 min.)	4 kV AC (50 Hz, 1 min.)
-40 °C ... 85 °C	-40 °C ... 85 °C
100% operating factor	100% operating factor
2 x 10 ⁷ cycles	1 x 10 ⁷ cycles
IEC 60664 , EN 50178 , EN 61810-1	IEC 60664 , EN 50178 , EN 61810-1
any / In rows with zero spacing	any / In rows with zero spacing
5 mm / 28 mm / 15 mm	5 mm / 28 mm / 16 mm

Technical data	
①	②
see diagram	
14	7
5	5
2.5	2.5
1 PDT	1 PDT
AgSnO	AgSnO, hard gold-plated
250 V AC/DC	30 V AC / 36 V DC
5 V (at 100 mA)	100 mV (at 10 mA)
6 A	50 mA
10 A (4 s)	50 mA
10 mA (at 12 V)	1 mA (at 24 V)
4 kV AC (50 Hz, 1 min.)	4 kV AC (50 Hz, 1 min.)
-40 °C ... 85 °C	-40 °C ... 85 °C
100% operating factor	100% operating factor
1 x 10 ⁷ cycles	1 x 10 ⁷ cycles
IEC 60664 , EN 50178 , EN 61810-1	IEC 60664 , EN 50178 , EN 61810-1
any / In rows with zero spacing	any / In rows with zero spacing
5 mm / 28 mm / 16 mm	5 mm / 28 mm / 16 mm

Description	Input voltage U_N
Plug-in miniature power relays, with power contacts	
	① 12 V DC
	② 24 V DC
Plug-in miniature power relays, with multi-layer gold contacts	
	① 12 V DC
	② 24 V DC

Ordering data		
Type	Order No.	Pcs./ Pkt.
REL-MR- 12DC/21	2961150	10
REL-MR- 24DC/21	2961105	10
REL-MR- 12DC/21AU	2961163	10
REL-MR- 24DC/21AU	2961121	10

Ordering data		
Type	Order No.	Pcs./ Pkt.
REL-MR- 12DC/21/MS	2909641	10
REL-MR- 24DC/21/MS	2909642	10
REL-MR- 12DC/21AU/MS	2909644	10
REL-MR- 24DC/21AU/MS	2909645	10

REL-MR-.../21... (1-PDT)

Input voltage range

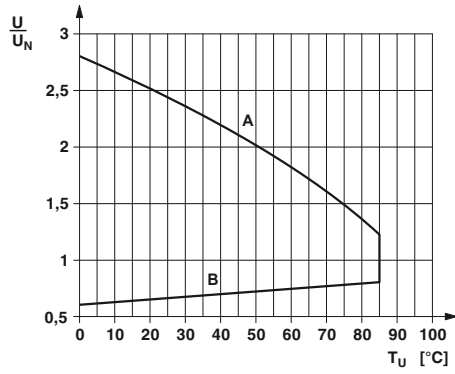

Interrupting rating

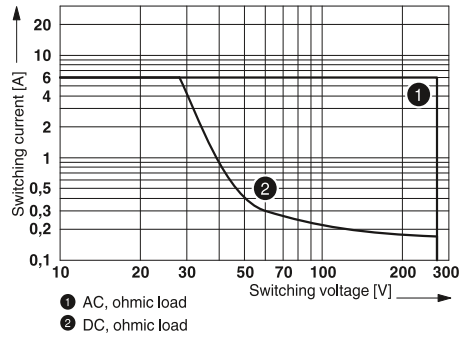

REL-MR-.../21.../MS (1-PDT)

Input voltage range

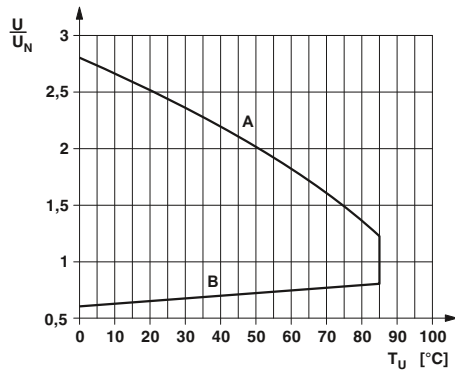

Interrupting rating

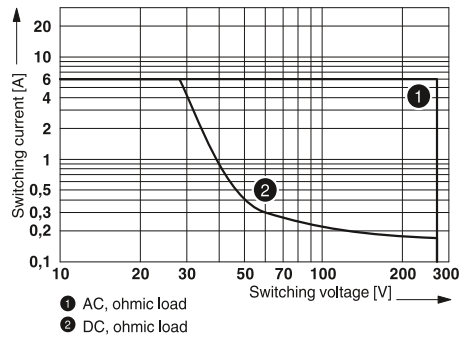

Relay modules

Industrial relay system - RIFLINE complete

Plug-in solid-state relays

Plug-in solid-state relays suitable for RIF-0 and PLC-INTERFACE relay bases.

The advantages:

- Switching current of up to 3 A
- RT III-proof (wash-proof)
- Vibration and shock-resistant
- Wear-free and long-lasting
- Zero voltage switch at AC output
- Can be soldered on PCB

Notes:
For dimensional drawings and perforations for assembly, see page 399
When mounting relays on a DIN rail base or PCB, data may be limited, especially with regard to the limiting continuous current and/or ambient temperature range. See "General" section in "Basics of relay technology" on page 286.



**Solid-state relay,
DC output max. 3 A**

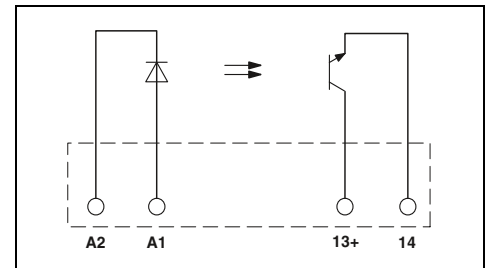

Input data	
Permissible range (with reference to U_N)	
Switching level	1 signal ("H") [V DC] \geq 16 0 signal ("L") [V DC] \leq 10
Typical input current at U_N	[mA] 7
Typical switch-on time at U_N	[μ s] 20
Typical switch-off time at U_N	[μ s] 300
Transmission frequency f_{limit}	[Hz] 300
Output data	
Max. switching voltage	33 V DC
Minimum switching voltage	3 V DC
Limiting continuous current	3 A (see derating curve)
Minimum load current	-
Maximum switch-on current	15 A (10 ms)
Leakage current in off state	-
Phase angle (cos ϕ)	-
Output circuit	2-wire, floating
Max. load value	-
Output protection	Reverse polarity protection, surge protection
Voltage drop at maximum limiting continuous current	\leq 150 mV
General data	
Rated surge voltage	Basic insulation
Test voltage input/output	2.5 kV (50 Hz, 1 min.)
Ambient temperature (operation)	-25 °C ... 60 °C
Nominal operating mode	100% operating factor
Standards/regulations	IEC 60664 , EN 50178
Degree of pollution/surge voltage category	2 / III
Mounting position/mounting	any / In rows with zero spacing
Dimensions	W / H / D 5 mm / 28 mm / 15 mm

Technical data

①	0,8 - 1,2
	16
	10
	7
	20
	300
	300
	33 V DC
	3 V DC
	3 A (see derating curve)
	-
	15 A (10 ms)
	-
	-
	2-wire, floating
	-
	Reverse polarity protection, surge protection
	\leq 150 mV
	Basic insulation
	2.5 kV (50 Hz, 1 min.)
	-25 °C ... 60 °C
	100% operating factor
	IEC 60664 , EN 50178
	2 / III
	any / In rows with zero spacing
	5 mm / 28 mm / 15 mm

Description	Input voltage U_N
Plug-in solid-state relays	
Solid-state power relays	① 24 V DC
Plug-in solid-state relays	
Solid-state input relays	① 24 V DC

Ordering data

Type	Order No.	Pcs./ Pkt.
OPT-24DC/ 24DC/ 2	2966595	10



Solid-state relay,
DC output max. 100 mA



Solid-state relay,
AC output max. 750 mA

Derating curve for OPT...DC/24DC/2 and PLC-OS.../24DC/2 solid-state relays

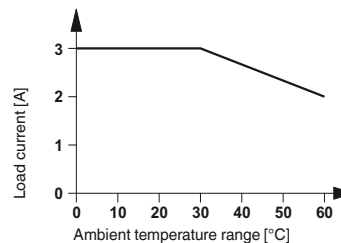

Derating curve for OPT...DC/230AC/1 and PLC-OS.../230AC/1 solid-state relays

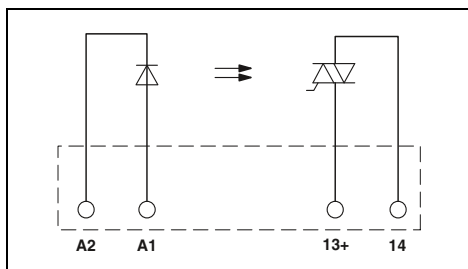
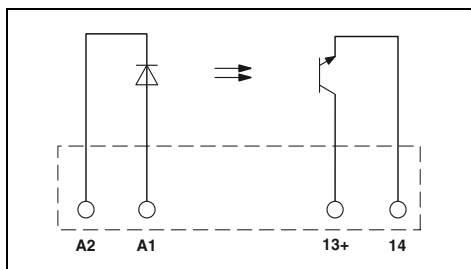
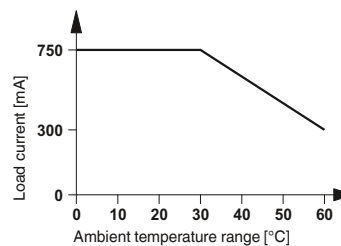

Technical data

Technical data

①
0.8 -
1.2
16
10
7
20
300
300

①
0.8 -
1.2
10
5
3
6000
500
10

48 V DC
3 V DC
100 mA
-
-
-
-
2-wire, floating
-
Reverse polarity protection, surge protection
≤ 1 V

253 V AC
24 V AC
0.75 A (see derating curve)
10 mA
30 A (10 ms)
< 1 mA
0.5
2-conductor floating, zero voltage switch
4.5 A ² s
RCV circuit
< 1 V

Basic insulation
2.5 kV (50 Hz, 1 min.)
-25 °C ... 60 °C
100% operating factor
IEC 60664 , EN 50178
2 / III
any / In rows with zero spacing
5 mm / 28 mm / 15 mm

Basic insulation
2.5 kV (50 Hz, 1 min.)
-25 °C ... 60 °C
100% operating factor
IEC 60664 , EN 50178
2 / III
any / In rows with zero spacing
5 mm / 28 mm / 15 mm

Ordering data

Ordering data

Type	Order No.	Pcs./ Pkt.
OPT-24DC/ 48DC/100	2966618	10

Type	Order No.	Pcs./ Pkt.
OPT-24DC/230AC/ 1	2967950	10

Relay modules

Industrial relay system - RIFLINE complete

Modular RIF-1 relay base

Relay base for assembly with 1 or 2-PDT relays or solid-state relays.

Range of accessories includes:

- Plug-in interference suppression module
- Plug-in timer module
- Relay retaining bracket with ejector function and holder for marking material
- Comprehensive range of marking material
- Test plug
- FBS 2-6 plug-in bridges for the input side (A2)
- FBS 2-8 plug-in bridges for the output side (11/21)

Notes:
Type of insulating housing: Polyamide PA, non-reinforced, color: gray.
For further marking systems and mounting material, see Catalog 3.
When mounting relays on a DIN rail base or PCB, data may be limited, especially with regard to the limiting continuous current and/or ambient temperature range. See "General" section in "Basics of relay technology" on page 286.

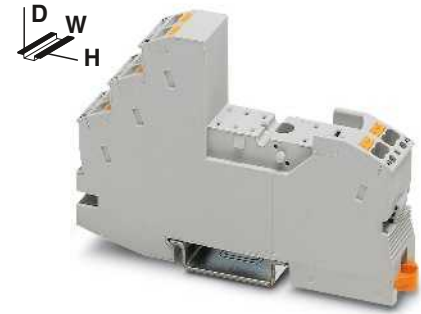

2-PDT relay base with Push-in connection technology



Nominal voltage U_N
Nominal current at U_N

General data

Ambient temperature (operation)

Connection data solid/stranded/AWG

Dimensions

Width

Depth with retaining bracket

Height

Technical data

250 V AC/DC

max. 13 A (Depends on application/assembly)

-40 °C ... 85 °C (Depends on application/assembly)

0.14 ... 1.5 mm² / 0.14 ... 1.5 mm² / 26 - 16

16 mm

75 mm

96 mm

Ordering data

Description

RIF-1 relay base, plug-in option for interference suppression module, safe isolation I/O with Push-in connection

RIF-1 relay base, plug-in option for interference suppression module, safe isolation I/O with screw connection

Relay retaining bracket, with ejector function and holder for marking material, suitable for RIF-1 relay base

- for 16 mm high miniature power and solid-state relays

- for 25 mm high miniature power relays

Relay retaining bracket, wire model, suitable for RIF-1 relay base

- for 16 mm high miniature power and solid-state relays

- for 25 mm high miniature power relays

Type

Order No.

Pcs./
Pkt.

RIF-1-BPT/2X21

2900931

10

Accessories

Plug-in bridge

2-pos. red, 32 A

2-pos. red, 24 A

2-pos. red, 32 A

2-pos. blue, 32 A

2-pos. gray, 32 A

2-pos. red, 41 A

2-pos. blue, 41 A

2-pos. gray, 41 A

End bracket, for snapping onto NS 35, 9.5 mm wide, can be marked with ZB 6, ZB 8/27, KLM...

Test plug, consisting of:

Metal part for 2.3 mm Ø socket hole and

silver

Insulating sleeve, for MPS metal part

red

white

blue

yellow

green

gray

black

Zack marker strip, unprinted

10-section

5-section

Double marker carrier for ZB 5

FBS 2-6

3030336

50

FBSR 2-6

3033715

50

FBSR 2-8

3033808

10

FBS 2-6 BU

3036932

50

FBS 2-6 GY

3032237

50

FBS 2-8

3030284

10

FBS 2-8 BU

3032567

10

FBS 2-8 GY

3032541

10

7042

CLIPFIX 35

3022218

50

MPS-MT

0201744

10

MPS-IH RD

0201676

10

MPS-IH WH

0201663

10

MPS-IH BU

0201689

10

MPS-IH YE

0201692

10

MPS-IH GN

0201702

10

MPS-IH GY

0201728

10

MPS-IH BK

0201731

10

ZB 5:UNBEDRUCKT

1050004

10

ZB 15:UNBEDRUCKT

0811972

10

STP 5-2

0800967

100



new

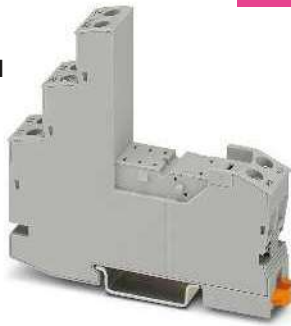

2-PDT relay base with screw connection technology



Plastic relay retaining bracket for RIF-1 base



Metal wire relay retaining bracket for RIF-1 base



Technical data			Technical data			Technical data		
250 V AC/DC max. 15.5 A (Depends on application/assembly)			-			-		
-40 °C ... 85 °C (Depends on application/assembly)			-			-		
0.14 ... 6 mm ² / 0.14 ... 4 mm ² / 26 - 10			-			-		
16 mm			-			-		
75 mm			-			-		
89 mm			-			-		
Ordering data			Ordering data			Ordering data		
Type	Order No.	Pcs./Pkt.	Type	Order No.	Pcs./Pkt.	Type	Order No.	Pcs./Pkt.
RIF-1-BSC/2X21	2900930	10						
			RIF-RH-1	2900953	10			
			RIF-RH-1-H	2904468	10			
						RIF-RHM-1	2905986	10
						RIF-RHM-1-H	2905985	10
Accessories			Accessories			Accessories		
FBS 2-6	3030336	50						
FBSR 2-6	3033715	50						
FBSR 2-8	3033808	10						
FBS 2-6 BU	3036932	50						
FBS 2-6 GY	3032237	50						
FBS 2-8	3030284	10						
FBS 2-8 BU	3032567	10						
FBS 2-8 GY	3032541	10						
	7042							
CLIPFIX 35	3022218	50						
MPS-MT	0201744	10						
MPS-IH RD	0201676	10						
MPS-IH WH	0201663	10						
MPS-IH BU	0201689	10						
MPS-IH YE	0201692	10						
MPS-IH GN	0201702	10						
MPS-IH GY	0201728	10						
MPS-IH BK	0201731	10						
ZB 5 :UNBEDRUCKT	1050004	10						
ZB 15:UNBEDRUCKT	0811972	10						
STP 5-2	0800967	100						

Relay modules

Industrial relay system - RIFLINE complete

Plug-in miniature power relays

Plug-in miniature power relays with 1 or 2 changeover contacts, suitable for the RIF-1 and PLC-INTERFACE relay bases.

The advantages:

- Power contacts up to 16 A
- Multi-layer gold contact or power contact
- High degree of protection up to RT III depending on type (wash-proof)



1-PDT relay,
max. 16 A



2-PDT relay,
max. 2 x 8 A

Notes:
If the specified maximum values for multi-layer contact relays are exceeded, the gold plating is destroyed. The maximum values of the power contact relay are then valid. This can result in a shorter service life than with a pure power contact.
When mounting relays on a DIN rail base or PCB, data may be limited, especially with regard to the limiting continuous current and/or ambient temperature range. See "General" section in "Basics of relay technology" on page 286.

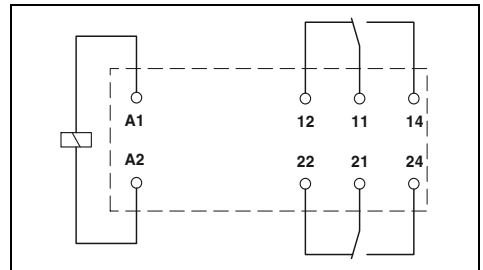
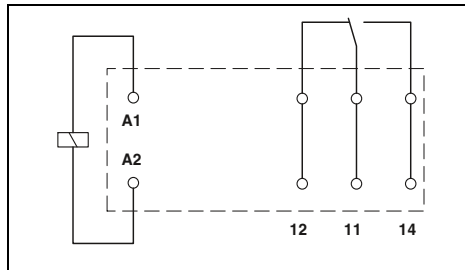

Input data	
Permissible range (with reference to U_N)	
Typical input current at U_N	[mA]
Typical response time at U_N	[ms]
Typical response time at U_N (depending on phase relation)	[ms]
Typical release time at U_N	[ms]
Typical release time at U_N (depending on phase relation)	[ms]
Output data	
Contact type	
Contact material	
Max. switching voltage	
Minimum switching voltage	
Limiting continuous current	
Maximum switch-on current AC	
Maximum switch-on current DC	
Minimum switching current	
General data	
Test voltage (winding / contact)	
Test voltage (contact/contact)	
Ambient temperature (operation), AC	
Ambient temperature (operation), DC	
Mechanical service life, AC	
Mechanical service life, DC	
Standards/regulations	

Technical data							
①	②	③	④	⑤	⑥	⑦	⑧
see diagram							
33	17	8.7	8.2	4.1	32	7	3
7	7	7	7	7	3-12	3-12	3-12
3	3	3	3	3	2-9	2-9	2-9
1 PDT				1 PDT			
AgNi				AgNi, hard gold-plated			
250 V AC/DC				30 V AC / 36 V DC			
12 V (at 10 mA)				100 mV (at 10 mA)			
16 A				50 mA			
25 A (20 ms)				50 mA			
50 A (20 ms)				50 mA			
10 mA (at 12 V)				1 mA (at 24 V)			
5 kV AC (50 Hz, 1 min.)							
-							
-40 °C ... 85 °C							
-40 °C ... 85 °C							
1 x 10 ⁷ cycles							
3 x 10 ⁷ cycles							
IEC 60664, EN 50178, EN 61810-1							

Technical data							
①	②	③	④	⑤	⑥	⑦	⑧
see diagram							
33	17	8.7	8.2	4.1	32	7	3
7	7	7	7	7	3-12	3-12	3-12
3	3	3	3	3	2-9	2-9	2-9
2 PDT				2 PDT			
AgNi				AgNi, hard gold-plated			
250 V AC/DC				30 V AC / 36 V DC			
5 V (at 10 mA)				100 mV (at 10 mA)			
8 A				50 mA			
12 A (20 ms)				50 mA			
25 A (20 ms)				50 mA			
10 mA (At 5 V)				1 mA (at 24 V)			
5 kV AC (50 Hz, 1 min.)							
2.5 kV AC (50 Hz, 1 min.)							
-40 °C ... 85 °C							
-40 °C ... 85 °C							
1 x 10 ⁷ cycles							
3 x 10 ⁷ cycles							
IEC 60664, EN 50178, EN 61810-1							

Description		Input voltage U_N
Plug-in miniature power relays, with power contacts		
	①	12 V DC
	②	24 V DC
	③	48 V DC
	④	60 V DC
	⑤	110 V DC
	⑥	24 V AC
	⑦	120 V AC
	⑧	230 V AC
Plug-in miniature power relays, with multi-layer gold contacts		
	①	12 V DC
	②	24 V DC
	③	48 V DC
	④	60 V DC
	⑤	110 V DC
	⑥	24 V AC
	⑦	120 V AC
	⑧	230 V AC

Ordering data		
Type	Order No.	Pcs./ Pkt.
REL-MR- 12DC/21HC	2961309	10
REL-MR- 24DC/21HC	2961312	10
REL-MR- 48DC/21HC	2834821	10
REL-MR- 60DC/21HC	2961325	10
REL-MR-110DC/21HC	2961338	10
REL-MR- 24AC/21HC	2961406	10
REL-MR-120AC/21HC	2961419	10
REL-MR-230AC/21HC	2961422	10
REL-MR- 12DC/21HC AU	2961532	10
REL-MR- 24DC/21HC AU	2961545	10
REL-MR-110DC/21HC AU	2961561	10
REL-MR- 24AC/21HC AU	2961503	10
REL-MR-120AC/21HC AU	2961516	10
REL-MR-230AC/21HC AU	2961529	10

Ordering data		
Type	Order No.	Pcs./ Pkt.
REL-MR- 12DC/21-21	2961257	10
REL-MR- 24DC/21-21	2961192	10
REL-MR- 48DC/21-21	2834834	10
REL-MR- 60DC/21-21	2961273	10
REL-MR-110DC/21-21	2961202	10
REL-MR- 24AC/21-21	2961435	10
REL-MR-120AC/21-21	2961448	10
REL-MR-230AC/21-21	2961451	10
REL-MR- 12DC/21-21AU	2961299	10
REL-MR- 24DC/21-21AU	2961215	10
REL-MR- 48DC/21-21AU	2834847	10
REL-MR- 60DC/21-21AU	2961286	10
REL-MR-110DC/21-21AU	2961228	10
REL-MR- 24AC/21-21AU	2961464	10
REL-MR-120AC/21-21AU	2961477	10
REL-MR-230AC/21-21AU	2961480	10

REL-MR...21HC... (1-PDT)

Operating voltage range

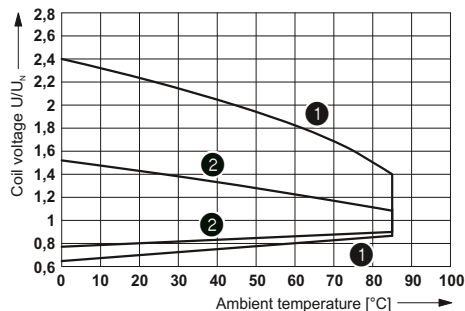

- 1 DC coils
- 2 AC coils

Interrupting rating

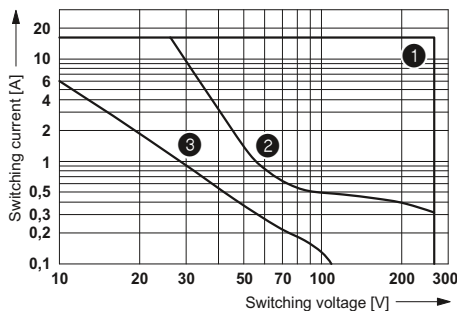

- 1 AC, ohmic load
- 2 DC, ohmic load
- 3 DC, L/R = 40 ms

Electrical service life

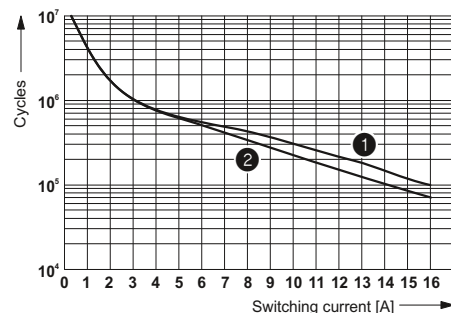

- 1 250 V AC, ohmic load (DC coils)
- 2 250 V AC, ohmic load (AC coils)

Service life reduction factor with various cos phi

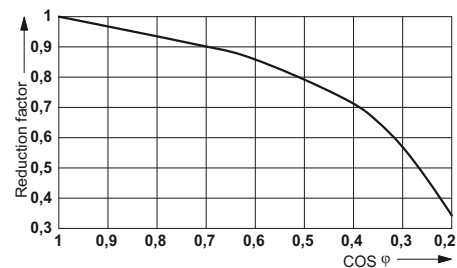

REL-MR...21-21... (2-PDT)

Operating voltage range

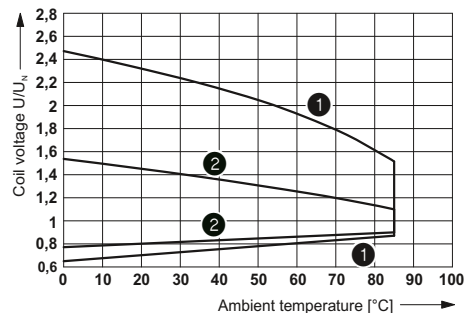

- 1 DC coils
- 2 AC coils

Interrupting rating

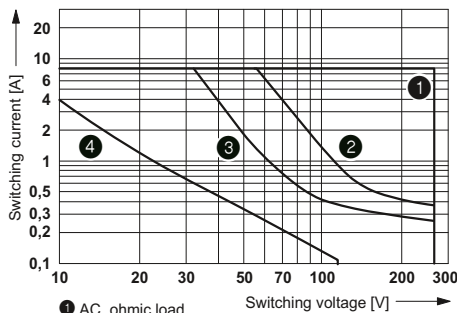

- 1 AC, ohmic load
- 2 DC, ohmic load, contacts in series
- 3 DC, ohmic load
- 4 DC, L/R = 40 ms

Electrical service life

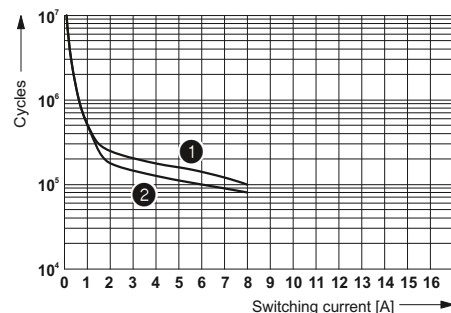

- 1 250 V AC, ohmic load (DC coils)
- 2 250 V AC, ohmic load (AC coils)

Service life reduction factor with various cos phi

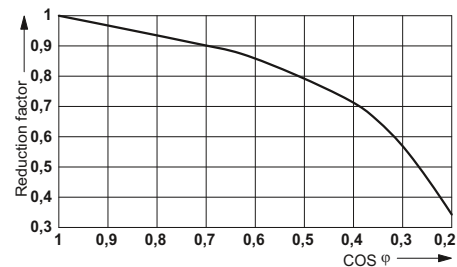

Relay modules

Industrial relay system - RIFLINE complete

Plug-in miniature power relays

Plug-in miniature power relays with 1 or 2 changeover contacts, suitable for the RIF-1 relay base.

The advantages:

- Switching current of up to 16 A
- With lockable manual operation
- Mechanical switch position indicator
- Integrated status LED
- Multi-layer gold contact or power contact
- DC types with integrated freewheeling diode
- Can be soldered on PCB



1-PDT relay with manual operation, 16 A, maximum



2-PDT relay with manual operation, 2 x 8 A, maximum

Notes:
If the specified maximum values for multi-layer contact relays are exceeded, the gold plating is destroyed. The maximum values of the power contact relay are then valid. This can result in a shorter service life than with a pure power contact.
When mounting relays on a DIN rail base or PCB, data may be limited, especially with regard to the limiting continuous current and/or ambient temperature range. See "General" section in "Basics of relay technology" on page 286.

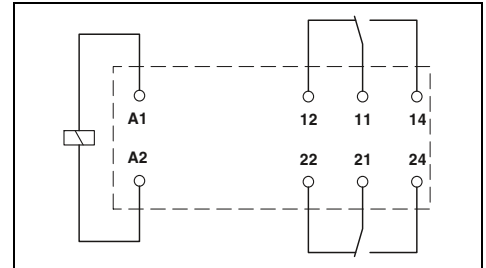
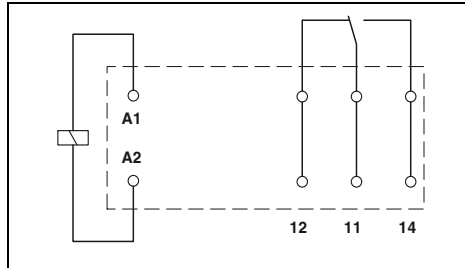

Input data	
Permissible range (with reference to U_N)	
Typical input current at U_N	[mA]
Typical response time at U_N	[ms]
Typical response time at U_N (depending on phase relation)	[ms]
Typical release time at U_N	[ms]
Typical release time at U_N (depending on phase relation)	[ms]
Output data	
Contact type	
Contact material	
Max. switching voltage	
Minimum switching voltage	
Limiting continuous current	
Maximum switch-on current AC	
Maximum switch-on current DC	
Minimum switching current	
General data	
Test voltage (winding / contact)	
Test voltage (contact/contact)	
Ambient temperature (operation), AC	
Ambient temperature (operation), DC	
Mechanical service life, AC	
Mechanical service life, DC	
Standards/regulations	

Technical data			
①	②	③	④
see diagram			
18	32	7	3.5
9		3 - 12	3 - 12
6		2 - 8	2 - 8
1 PDT		1 PDT	
AgNi		AgNi, hard gold-plated	
250 V AC/DC		30 V AC / 36 V DC	
12 V (at 10 mA)		12 V (At 1 mA)	
16 A		50 mA	
32 A (20 ms)		50 mA	
32 A (20 ms)		50 mA	
10 mA (at 12 V)		1 mA (at 12 V)	
5 kV AC (50 Hz, 1 min.)			
-40 °C ... 70 °C			
-40 °C ... 70 °C			
5 x 10 ⁶ cycles			
5 x 10 ⁶ cycles			
EN 61810-1, VDE 0435-201, EN 50178			

Technical data			
①	②	③	④
see diagram			
18	32	7	3.5
9		3 - 12	3 - 12
6		2 - 8	2 - 8
2 PDT		2 PDT	
AgNi		AgNi, hard gold-plated	
250 V AC/DC		30 V AC / 36 V DC	
12 V (at 10 mA)		12 V (At 1 mA)	
8 A		50 mA	
16 A (20 ms)		50 mA	
16 A (20 ms)		50 mA	
10 mA (at 12 V)		1 mA (at 12 V)	
5 kV AC (50 Hz, 1 min.)			
-40 °C ... 70 °C			
-40 °C ... 70 °C			
5 x 10 ⁶ cycles			
5 x 10 ⁶ cycles			
EN 61810-1, VDE 0435-201, EN 50178			

Description	Input voltage U_N
Plug-in miniature power relays, with power contacts	
- Status LED, freewheeling diode A1+, A2-	① 24 V DC
- Status LED	② 24 V AC
- Status LED	③ 120 V AC
- Status LED	④ 230 V AC
Plug-in miniature power relays, with multi-layer gold contacts, with manual operation, mechanical switch position indicator	
- Status LED, freewheeling diode A1+, A2-	① 24 V DC
- Status LED	⑤ 230 V AC

Ordering data		
Type	Order No.	Pcs./ Pkt.
REL-MR- 24DC/21HC/MS	2987888	10
REL-MR- 24AC/21HC/MS	2987891	10
REL-MR-120AC/21HC/MS	2987901	10
REL-MR-230AC/21HC/MS	2987914	10
REL-MR- 24DC/21HC AU/MS	2987927	10
REL-MR-230AC/21HC AU/MS	2987930	10

Ordering data		
Type	Order No.	Pcs./ Pkt.
REL-MR- 24DC/21-21/MS	2987943	10
REL-MR- 24AC/21-21/MS	2987956	10
REL-MR-120AC/21-21/MS	2987969	10
REL-MR-230AC/21-21/MS	2987972	10
REL-MR- 24DC/21-21AU/MS	2987985	10
REL-MR-230AC/21-21AU/MS	2987998	10

REL-MR...21HC...MS (1-PDT)

Operating voltage range

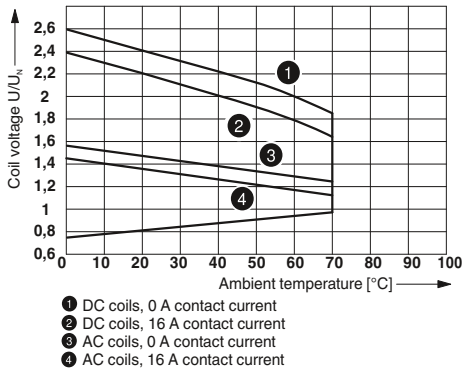

Interrupting rating

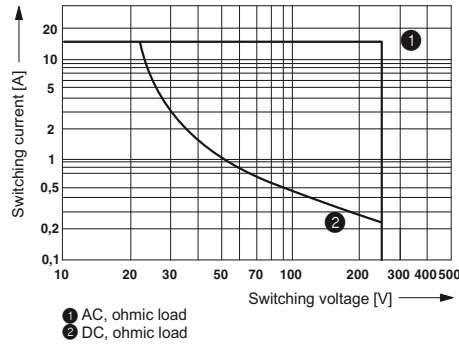

Electrical service life

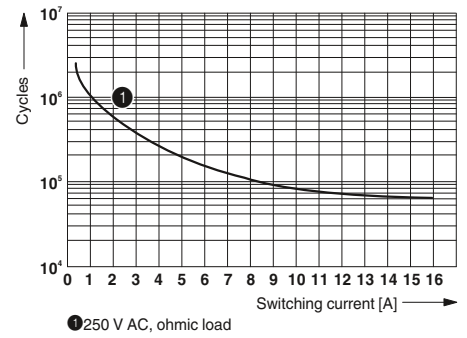

Service life reduction factor with various cos phi

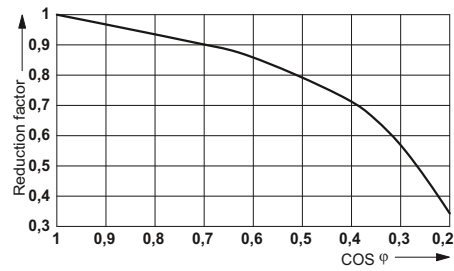

REL-MR...21-21...MS (2-PDT)

Operating voltage range

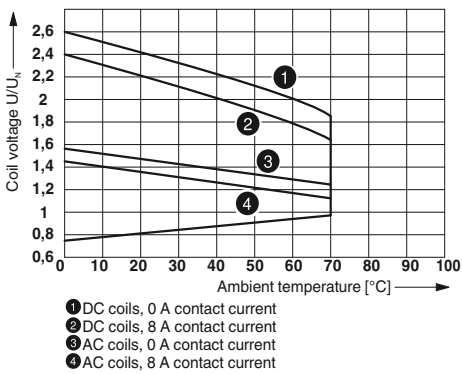

Interrupting rating

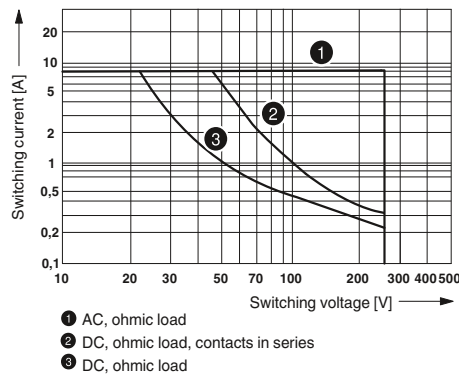

Electrical service life

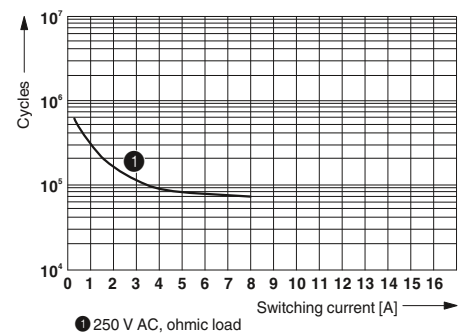

Service life reduction factor with various cos phi

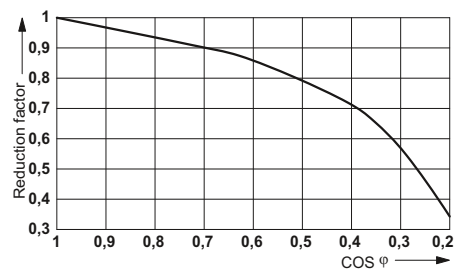

Relay modules

Industrial relay system - RIFLINE complete

Bipolar, plug-in miniature power relays

new

new

Bipolar, plug-in miniature power relays with 1 or 2 changeover contacts, suitable for the RIF-1 relay base.

The advantages:

- Switching current of up to 16 A
- With detectable manual operation
- Mechanical switch position indicator
- Multi-layer power contact
- Can be soldered on PCB
- Special voltages (100 and 200 V AC)



1-PDT relay (bipolar) with manual operation, max. 16 A



2-PDT relay (bipolar) with manual operation, max. 2 x 8 A

Notes:

When mounting relays on a DIN rail base or PCB, data may be limited, especially with regard to the limiting continuous current and/or ambient temperature range. See "General" section in "Basics of relay technology" on page 286.

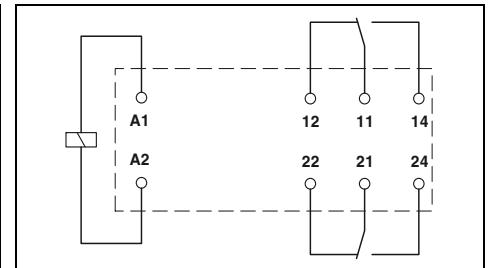
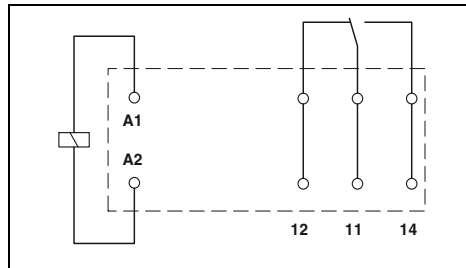

Technical data

Technical data

Input data	①	②	③
Permissible range (with reference to U_N)	see diagram		
Typical input current at U_N	17	8	4
Typical response time at U_N	9		
Typical response time at U_N (depending on phase relation)		3 - 12	3 - 12
Typical release time at U_N	6		
Typical release time at U_N (depending on phase relation)		2 - 8	2 - 8
Output data			
Contact type	1 PDT		
Contact material	AgNi		
Max. switching voltage	250 V AC/DC		
Minimum switching voltage	12 V (at 10 mA)		
Limiting continuous current	16 A		
Maximum switch-on current AC	32 A (20 ms)		
Maximum switch-on current DC	32 A (20 ms)		
Minimum switching current	10 mA (at 12 V)		
General data			
Test voltage (winding / contact)	5 kV AC (50 Hz, 1 min.)		
Ambient temperature (operation), AC	-40 °C ... 70 °C		
Ambient temperature (operation), DC	-40 °C ... 70 °C		
Mechanical service life, AC	5 x 10 ⁶ cycles		
Mechanical service life, DC	5 x 10 ⁶ cycles		
Standards/regulations	IEC 61810 , IEC 60664		

Input data	①	②	③
Permissible range (with reference to U_N)	see diagram		
Typical input current at U_N	17	8	4
Typical response time at U_N	9		
Typical response time at U_N (depending on phase relation)		3 - 12	3 - 12
Typical release time at U_N	6		
Typical release time at U_N (depending on phase relation)		2 - 8	2 - 8
Output data			
Contact type	2 PDT		
Contact material	AgNi		
Max. switching voltage	250 V AC/DC		
Minimum switching voltage	12 V (at 10 mA)		
Limiting continuous current	8 A		
Maximum switch-on current AC	16 A (20 ms)		
Maximum switch-on current DC	16 A (20 ms)		
Minimum switching current	10 mA (at 12 V)		
General data			
Test voltage (winding / contact)	5 kV AC (50 Hz, 1 min.)		
Ambient temperature (operation), AC	-40 °C ... 70 °C		
Ambient temperature (operation), DC	-40 °C ... 70 °C		
Mechanical service life, AC	5 x 10 ⁶ cycles		
Mechanical service life, DC	5 x 10 ⁶ cycles		
Standards/regulations	IEC 61810 , IEC 60664		

Ordering data

Ordering data

Description	Input voltage U_N	Type	Order No.	Pcs./ Pkt.
Bipolar, plug-in miniature power relays, with power contacts	① 24 V DC	REL-MR-BL-24DC/21HC/MS	2908180	10
	② 100 V AC	REL-MR-BL-100AC/21HC/MS	2908179	10
	③ 200 V AC	REL-MR-BL-200AC/21HC/MS	2908178	10

Description	Input voltage U_N	Type	Order No.	Pcs./ Pkt.
Bipolar, plug-in miniature power relays, with power contacts	① 24 V DC	REL-MR-BL-24DC/21-21/MS	2908181	10
	② 100 V AC	REL-MR-BL-100AC/21-21/MS	2908183	10
	③ 200 V AC	REL-MR-BL-200AC/21-21/MS	2908182	10

REL-MR-BL...21HC/MS (1-PDT)

Operating voltage range

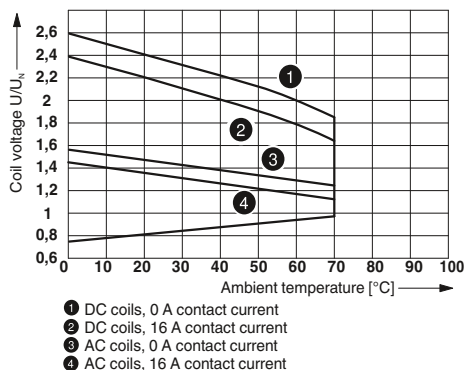

Interrupting rating

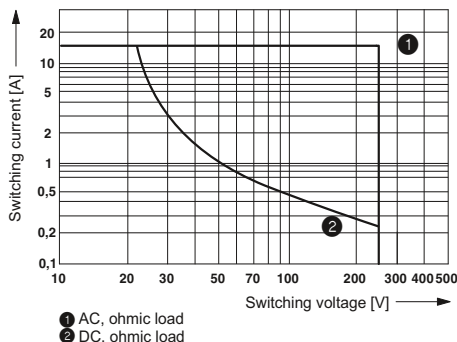

Electrical service life

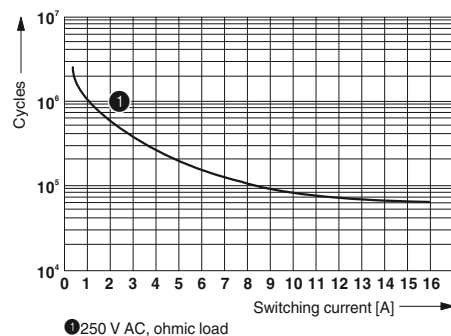

Service life reduction factor with various cos phi

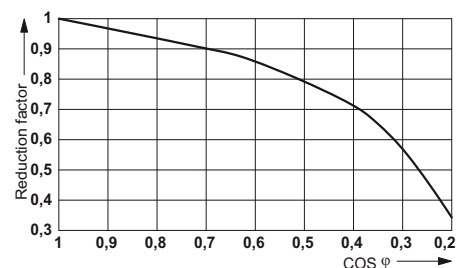

REL-MR-BL...21-21/MS (2-PDT)

Operating voltage range

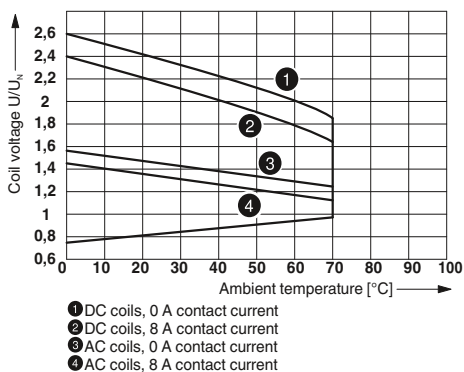

Interrupting rating

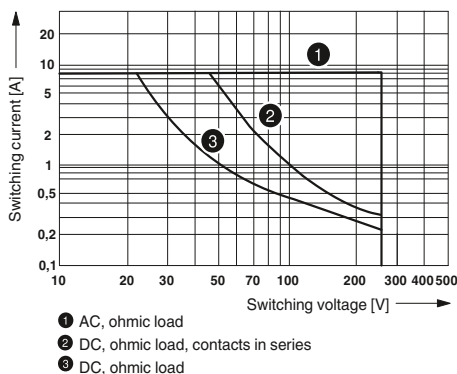

Electrical service life

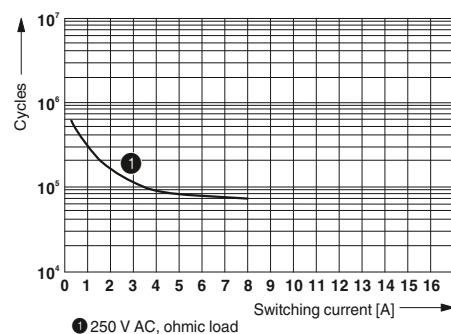

Service life reduction factor with various cos phi

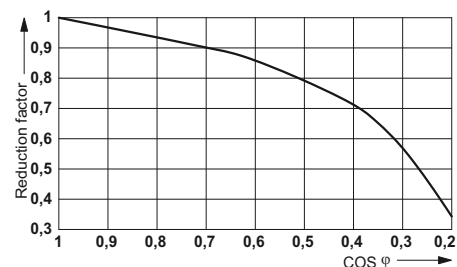

Relay modules

Industrial relay system - RIFLINE complete

Plug-in solid-state relays

Plug-in solid-state relays are suitable for both relay bases RIF-1 and PLC-INTERFACE.

The advantages:

- Switching current of up to 5 A
- RT III-proof (wash-proof)
- Vibration and shock-resistant
- Wear-free and long-lasting
- Zero voltage switch at AC output
- Can be soldered on PCB

Notes:
For dimensional drawings and perforations for assembly, see page 399
When mounting relays on a DIN rail base or PCB, data may be limited, especially with regard to the limiting continuous current and/or ambient temperature range. See "General" section in "Basics of relay technology" on page 286.



**Solid-state relay,
DC output max. 5 A**

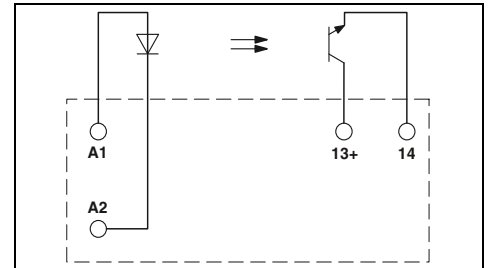

Input data	
Permissible range (with reference to U_N)	
Switching level	1 signal ("H") [V DC] \geq 0 signal ("L") [V DC] \leq
Typical input current at U_N	[mA]
Typical switch-on time at U_N	[μ s]
Typical switch-off time at U_N	[μ s]
Transmission frequency f_{limit}	[Hz]
Output data	
Max. switching voltage	33 V DC
Minimum switching voltage	3 V DC
Limiting continuous current	5 A (see derating curve)
Minimum load current	-
Maximum switch-on current	15 A (10 ms)
Leakage current in off state	-
Output circuit	2-wire, floating
Max. load value	-
Output protection	Reverse polarity protection, surge protection
Voltage drop at maximum limiting continuous current	\leq 200 mV
General data	
Rated surge voltage	Basic insulation
Test voltage input/output	2.5 kV (50 Hz, 1 min.)
Ambient temperature (operation)	-25 °C ... 60 °C
Nominal operating mode	100% operating factor
Standards/regulations	IEC 60664, EN 50178
Degree of pollution/surge voltage category	2 / III
Mounting position/mounting	any / In rows with zero spacing
Dimensions	W / H / D 12.7 mm / 29 mm / 15.7 mm

Technical data

①	②	③
0.8 - 1.2	0.8 - 1.2	0.9 - 1.1
2.5	16	35
0.8	10	20
9	7	3
10	20	25
400	400	400
300	300	300

Max. switching voltage	33 V DC
Minimum switching voltage	3 V DC
Limiting continuous current	5 A (see derating curve)
Minimum load current	-
Maximum switch-on current	15 A (10 ms)
Leakage current in off state	-
Output circuit	2-wire, floating
Max. load value	-
Output protection	Reverse polarity protection, surge protection
Voltage drop at maximum limiting continuous current	\leq 200 mV

Rated surge voltage	Basic insulation
Test voltage input/output	2.5 kV (50 Hz, 1 min.)
Ambient temperature (operation)	-25 °C ... 60 °C
Nominal operating mode	100% operating factor
Standards/regulations	IEC 60664, EN 50178
Degree of pollution/surge voltage category	2 / III
Mounting position/mounting	any / In rows with zero spacing
Dimensions	W / H / D 12.7 mm / 29 mm / 15.7 mm

Ordering data

Description	Input voltage U_N
Plug-in solid-state relays	
Solid-state power relays	① 5 V DC
Solid-state power relays	② 24 V DC
Solid-state power relays	③ 60 V DC

Type	Order No.	Pcs./Pkt.
OPT-5DC/ 24DC/ 5	2982113	10
OPT-24DC/ 24DC/ 5	2982100	10
OPT-60DC/ 24DC/ 5	2982126	10



Solid-state relay,
AC output max. 2 A

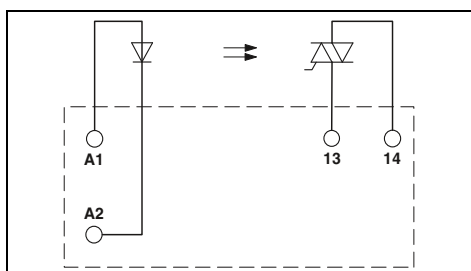

Technical data

①	②
0.8 -	0.8 -
1.2	1.2
3	18
1	8.4
15	7
10000	10000
10000	10000
10	10

253 V AC
 24 V AC
 2 A (see derating curve)
 25 mA
 30 A (10 ms)
 < 1 mA
 2-conductor floating, zero voltage switch
 4 A²s (tp = 10 ms, at 25 °C)
 Surge protection
 ≤ 1 V

Basic insulation
 2.5 kV (50 Hz, 1 min.)
 -25 °C ... 60 °C
 100% operating factor
 IEC 60664 , EN 50178
 2 / III
 any / See derating curve
 12.7 mm / 29 mm / 15.7 mm

Ordering data

Type	Order No.	Pcs./ Pkt.
OPT-5DC/230AC/ 2	2982168	10
OPT-24DC/230AC/ 2	2982171	10

Derating curve for OPT...DC/24DC/5 solid-state relays

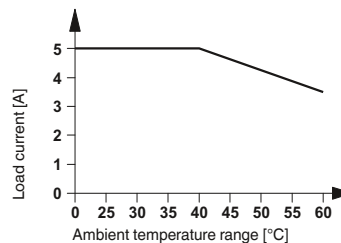

Derating curve for OPT...DC/230AC/2 solid-state relays

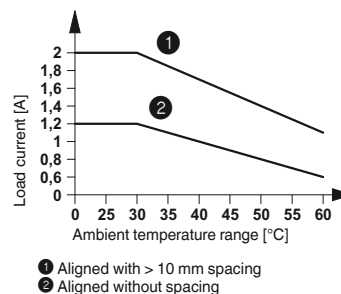

- ① Aligned with > 10 mm spacing
- ② Aligned without spacing

Relay modules

Industrial relay system - RIFLINE complete

Modular RIF-2 relay base

Relay base for assembly with 2 or 4-PDT industrial relay.

Range of accessories includes:

- Plug-in interference suppression module
- Plug-in timer module
- Relay retaining bracket with ejector function and holder for marking material
- Comprehensive range of marking material
- Test plug
- FBS 2-6 plug-in bridges for the input side (A2)

Notes:
Type of insulating housing: Polyamide PA, non-reinforced, color: gray.
For further marking systems and mounting material, see Catalog 3.
When mounting relays on a DIN rail base or PCB, data may be limited, especially with regard to the limiting continuous current and/or ambient temperature range. See "General" section in "Basics of relay technology" on page 286.



4-PDT relay base with Push-in connection technology for industrial relays



Nominal voltage U_N
Nominal current at U_N

Technical data
250 V AC/DC max. 12 A (Depends on application/assembly)

General data
Ambient temperature (operation)
Connection data solid/stranded/AWG
Dimensions
Width
Depth with retaining bracket
Height

-40 °C ... 85 °C (Depends on application/assembly)
0.14 ... 1.5 mm ² / 0.14 ... 1.5 mm ² / 26 - 16
31 mm
75 mm
96 mm

Description
RIF-2 relay base , plug-in option for interference suppression module, safe isolation I/O with Push-in connection
RIF-2 relay base , plug-in option for interference suppression module, safe isolation I/O with screw connection
Plastic relay retaining bracket , with ejector function and holder for marking material, suitable for RIF-2 relay base
Reinforced plastic relay retaining bracket , with ejector function and holder for marking material, suitable for RIF-2 relay base
Relay retaining bracket , wire model, suitable for RIF-2 relay base

Ordering data		
Type	Order No.	Pcs./Pkt.
RIF-2-BPT/4X21	2900934	10

Plug-in bridge 2-pos. red, 32 A 2-pos. red, 24 A 2-pos. blue, 32 A 2-pos. gray, 32 A	
End bracket , for snapping onto NS 35, 9.5 mm wide, can be marked with ZB 6, ZB 8/27, KLM...	
Test plug , consisting of: Metal part for 2.3 mm Ø socket hole and	silver
Insulating sleeve , for MPS metal part	red white blue yellow green gray black
Zack marker strip , unprinted 10-section 5-section	
Double marker carrier for ZB 5	

Accessories		
FBS 2-6	3030336	50
FBSR 2-6	3033715	50
FBS 2-6 BU	3036932	50
FBS 2-6 GY	3032237	50
CLIPFIX 35	3022218	50
MPS-MT	0201744	10
MPS-IH RD	0201676	10
MPS-IH WH	0201663	10
MPS-IH BU	0201689	10
MPS-IH YE	0201692	10
MPS-IH GN	0201702	10
MPS-IH GY	0201728	10
MPS-IH BK	0201731	10
ZB 5 :UNBEDRUCKT	1050004	10
ZB 15:UNBEDRUCKT	0811972	10
STP 5-2	0800967	100



new

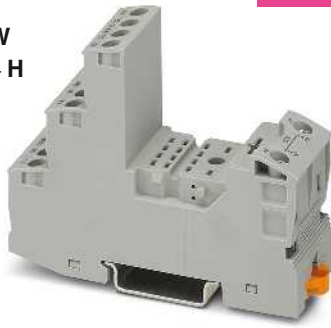

4-PDT relay base with screw connection technology for industrial relays



Plastic relay retaining bracket for RIF-2 base



Metal wire relay retaining bracket for RIF-2 base



Technical data			Technical data			Technical data		
250 V AC/DC max. 12 A (Depends on application/assembly)			-			-		
-40 °C ... 85 °C (Depends on application/assembly)			-			-		
0.14 ... 6 mm ² / 0.14 ... 4 mm ² / 26 - 10			-			-		
27 mm			-			-		
75 mm			-			-		
89 mm			-			-		
Ordering data			Ordering data			Ordering data		
Type	Order No.	Pcs./ Pkt.	Type	Order No.	Pcs./ Pkt.	Type	Order No.	Pcs./ Pkt.
RIF-2-BSC/4X21	2900932	10						
			RIF-RH-2	2900954	10			
			RIF-RHS-2	2908043	10			
						RIF-RHM-2	2905984	10
Accessories			Accessories			Accessories		
FBS 2-6	3030336	50						
FBSR 2-6	3033715	50						
FBS 2-6 BU	3036932	50						
FBS 2-6 GY	3032237	50						
CLIPFIX 35	3022218	50						
MPS-MT	0201744	10						
MPS-IH RD	0201676	10						
MPS-IH WH	0201663	10						
MPS-IH BU	0201689	10						
MPS-IH YE	0201692	10						
MPS-IH GN	0201702	10						
MPS-IH GY	0201728	10						
MPS-IH BK	0201731	10						
ZB 5 :UNBEDRUCKT	1050004	10						
ZB 15:UNBEDRUCKT	0811972	10						
STP 5-2	0800967	100						

Relay modules

Industrial relay system - RIFLINE complete

Plug-in industrial relays

Plug-in industrial relays with 2 or 4 changeover contacts, suitable for RIF-2 relay base.

The advantages:

- With detectable manual operation
- Mechanical switch position indicator
- Integrated status LED
- Multi-layer gold contact or power contact
- DC types with integrated freewheeling diode



2-PDT industrial relay with manual operation, max. 2 x 12 A



4-PDT industrial relay with manual operation, max. 4 x 6 A

Notes:
For other voltages, see phoenixcontact.net/products
When mounting relays on a DIN rail base or PCB, data may be limited, especially with regard to the limiting continuous current and/or ambient temperature range. See "General" section in "Basics of relay technology" on page 286.

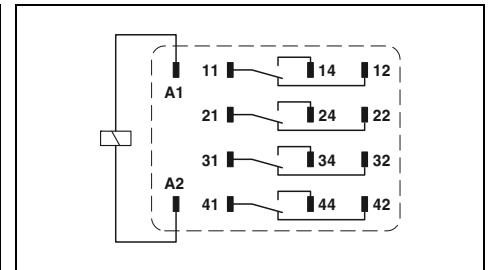
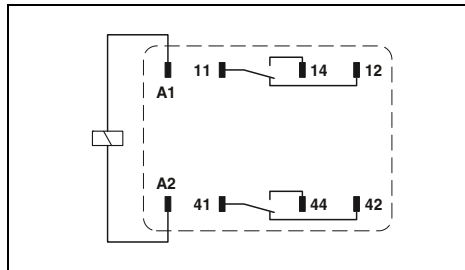

Technical data

Input data	①	②	③	④	⑤	⑥	⑦	⑧
Permissible range (with reference to U_N)	see diagram							
Typical input current at U_N [mA]	78	42	8	7.7	4	66	13	6.5
Typical response time at U_N [ms]	13	13	13	13	13			
Typical response time at U_N (depending on phase relation) [ms]						5 - 15	5 - 15	5 - 15
Typical release time at U_N [ms]	14	14	14	14	14			
Typical release time at U_N (depending on phase relation) [ms]						5 - 20	5 - 20	5 - 20
Output data								
Contact type	2 PDT							
Contact material	AgNi							
Max. switching voltage	250 V AC/DC							
Minimum switching voltage	5 V (At 24 mA)							
Limiting continuous current	12 A							
Maximum switch-on current AC	30 A (20 ms, N/O contact)							
Maximum switch-on current DC	30 A (20 ms, N/O contact)							
Minimum switching current	5 mA (at 24 V)							
General data								
Test voltage (winding / contact)	2.5 kV _{rms} (50 Hz, 1 min.)							
Ambient temperature (operation), AC	-40 °C ... 55 °C							
Ambient temperature (operation), DC	-40 °C ... 70 °C							
Mechanical service life, AC	Approx. 2x 10 ⁷ cycles							
Mechanical service life, DC	Approx. 2x 10 ⁷ cycles							
Standards/regulations	IEC 60664 , IEC 61810							

Technical data

Input data	①	②	③	④	⑤	⑥	⑦	⑧
Permissible range (with reference to U_N)	see diagram							
Typical input current at U_N [mA]	78	42	8	7.7	4	66	13	6.5
Typical response time at U_N [ms]	13	13	13	13	13			
Typical response time at U_N (depending on phase relation) [ms]						5 - 15	5 - 15	5 - 15
Typical release time at U_N [ms]	14	14	14	14	14			
Typical release time at U_N (depending on phase relation) [ms]						5 - 20	5 - 20	5 - 20
Output data								
Contact type	4 PDT				4 PDT			
Contact material	AgNi				AgNi, hard gold-plated			
Max. switching voltage	250 V AC/DC				30 V AC / 36 V DC			
Minimum switching voltage	5 V (At 24 mA)				5 V (At 24 mA)			
Limiting continuous current	6 A				50 mA			
Maximum switch-on current AC	16 A (20 ms, N/O contact)				50 mA			
Maximum switch-on current DC	16 A (20 ms, N/O contact)				50 mA			
Minimum switching current	5 mA (at 24 V)				-			
General data								
Test voltage (winding / contact)	2.5 kV _{rms} (50 Hz, 1 min.)							
Ambient temperature (operation), AC	-40 °C ... 55 °C							
Ambient temperature (operation), DC	-40 °C ... 70 °C							
Mechanical service life, AC	Approx. 2x 10 ⁷ cycles							
Mechanical service life, DC	Approx. 2x 10 ⁷ cycles							
Standards/regulations	IEC 60664 , IEC 61810							

Ordering data

Description	Input voltage U_N	Type	Order No.	Pcs./ Pkt.
Plug-in industrial relays, with power contacts				
With freewheeling diode	① 12 V DC	REL-IR2/LDP- 12DC/2X21	2903659	10
With freewheeling diode	② 24 V DC	REL-IR2/LDP- 24DC/2X21	2903660	10
With freewheeling diode	③ 110 V DC	REL-IR2/LDP-110DC/2X21	2903663	10
With freewheeling diode	④ 125 V DC	REL-IR2/LDP-125DC/2X21	2903664	10
With freewheeling diode	⑤ 220 V DC	REL-IR2/LDP-220DC/2X21	2903665	10
	⑥ 24 V AC	REL-IR2/L- 24AC/2X21	2903666	10
	⑦ 120 V AC	REL-IR2/L-120AC/2X21	2903667	10
	⑧ 230 V AC	REL-IR2/L-230AC/2X21	2903668	10
Plug-in industrial relays, with multi-layer gold contacts				
With freewheeling diode	① 12 V DC			
With freewheeling diode	② 24 V DC			
With freewheeling diode	③ 110 V DC			
With freewheeling diode	④ 125 V DC			
With freewheeling diode	⑤ 220 V DC			
	⑥ 24 V AC			
	⑦ 120 V AC			
	⑧ 230 V AC			

Ordering data

Type	Order No.	Pcs./ Pkt.
REL-IR4/LDP- 12DC/4X21	2903676	10
REL-IR4/LDP- 24DC/4X21	2903677	10
REL-IR4/LDP-110DC/4X21	2903680	10
REL-IR4/LDP-125DC/4X21	2903681	10
REL-IR4/LDP-220DC/4X21	2903682	10
REL-IR4/L- 24AC/4X21	2903686	10
REL-IR4/L-120AC/4X21	2903687	10
REL-IR4/L-230AC/4X21	2903688	10
REL-IR4/LDP- 12DC/4X21AU	2903669	10
REL-IR4/LDP- 24DC/4X21AU	2903670	10
REL-IR4/LDP-110DC/4X21AU	2903673	10
REL-IR4/LDP-125DC/4X21AU	2903674	10
REL-IR4/LDP-220DC/4X21AU	2903675	10
REL-IR4/L- 24AC/4X21AU	2903683	10
REL-IR4/L-120AC/4X21AU	2903684	10
REL-IR4/L-230AC/4X21AU	2903685	10

REL-IR2... (2-PDT)

Operating voltage range

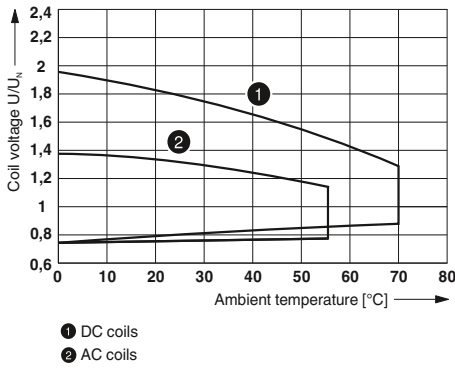

Interrupting rating

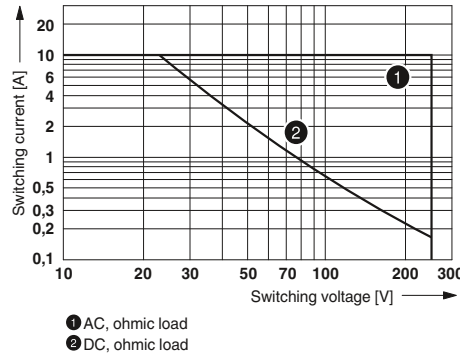

Electrical service life

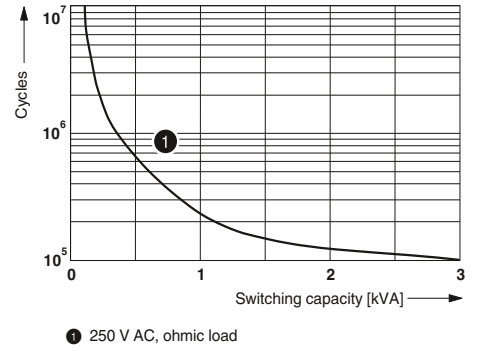

Service life reduction factor

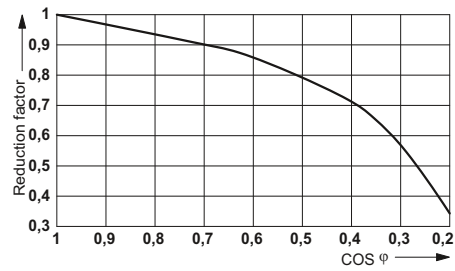

REL-IR4... (4-PDT)

Operating voltage range

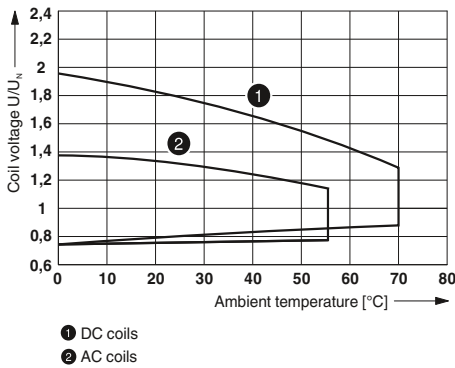

Interrupting rating

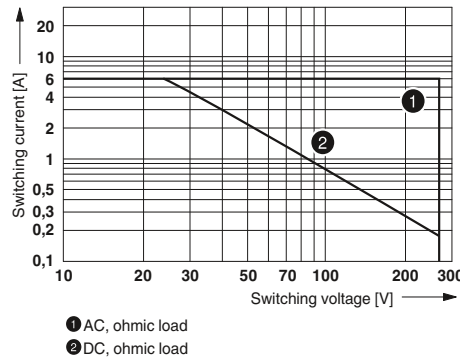

Electrical service life

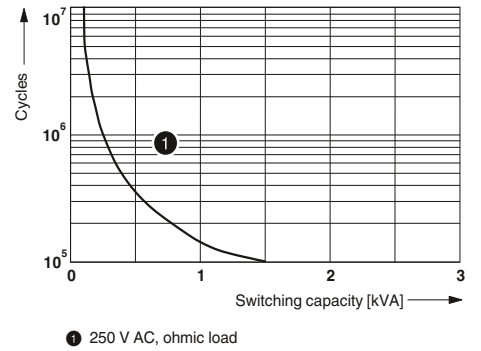

Service life reduction factor

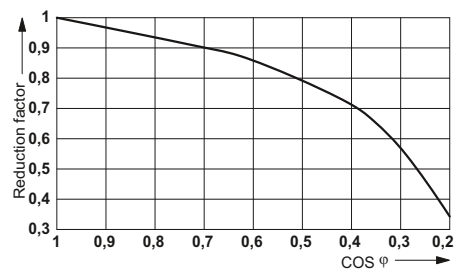

Relay modules

Industrial relay system - RIFLINE complete

Bipolar, plug-in industrial relays

new

new

Bipolar, plug-in industrial relays with 2 or 4 changeover contacts, suitable for the RIF-2 relay base.

The advantages:

- Switching current of up to 12 A
- With detectable manual operation
- Mechanical switch position indicator
- Special voltages (100 and 200 V AC)

Notes:
When mounting relays on a DIN rail base or PCB, data may be limited, especially with regard to the limiting continuous current and/or ambient temperature range. See "General" section in "Basics of relay technology" on page 286.



2-PDT industrial relay (bipolar) with manual operation, max. 2 x 12 A



4-PDT industrial relay (bipolar) with manual operation, max. 4 x 6 A

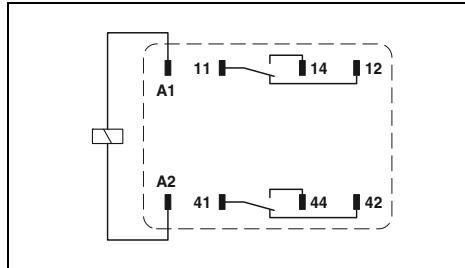

Technical data

	①	②	③
Input data	see diagram		
Permissible range (with reference to U_N)	38	14.8	7.1
Typical input current at U_N	[mA]		
Typical response time at U_N	[ms]	13	
Typical response time at U_N (depending on phase relation)	[ms]	5 - 15	5 - 15
Typical release time at U_N	[ms]	3	
Typical release time at U_N (depending on phase relation)	[ms]	5 - 20	5 - 20
Output data			
Contact type	2 PDT		
Contact material	AgNi		
Max. switching voltage	250 V AC/DC		
Minimum switching voltage	5 V (At 24 mA)		
Limiting continuous current	12 A		
Maximum switch-on current AC	30 A (20 ms, N/O contact)		
Maximum switch-on current DC	30 A (20 ms, N/O contact)		
Minimum switching current	5 mA (at 24 V)		
General data			
Test voltage (winding / contact)	2.5 kV _{rms} (50 Hz, 1 min.)		
Ambient temperature (operation), AC	-40 °C ... 55 °C		
Ambient temperature (operation), DC	-40 °C ... 70 °C		
Mechanical service life, AC	Approx. 2x 10 ⁷ cycles		
Mechanical service life, DC	Approx. 2x 10 ⁷ cycles		
Standards/regulations	IEC 60664 , IEC 61810		

Ordering data

Description	Input voltage U_N	Type	Order No.	Pcs./ Pkt.
Bipolar, plug-in industrial relays , with power contacts	① 24 V DC	REL-IR2/24DC/2X21	2907051	10
	② 100 V AC	REL-IR2/100AC/2X21	2907052	10
	③ 200 V AC	REL-IR2/200AC/2X21	2907053	10

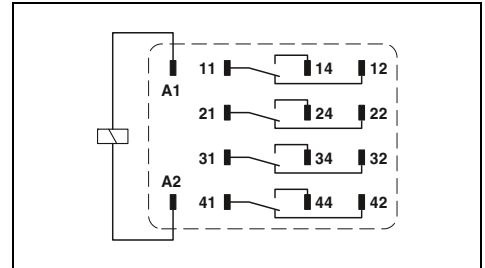

Technical data

	①	②	③
Input data	see diagram		
Permissible range (with reference to U_N)	38	14.8	7.1
Typical input current at U_N	[mA]		
Typical response time at U_N	[ms]	13	
Typical response time at U_N (depending on phase relation)	[ms]	5 - 15	5 - 15
Typical release time at U_N	[ms]	3	
Typical release time at U_N (depending on phase relation)	[ms]	5 - 20	5 - 20
Output data			
Contact type	4 PDT		
Contact material	AgNi		
Max. switching voltage	250 V AC/DC		
Minimum switching voltage	5 V (At 24 mA)		
Limiting continuous current	6 A		
Maximum switch-on current AC	16 A (20 ms, N/O contact)		
Maximum switch-on current DC	16 A (20 ms, N/O contact)		
Minimum switching current	5 mA (at 24 V)		
General data			
Test voltage (winding / contact)	2.5 kV _{rms} (50 Hz, 1 min.)		
Ambient temperature (operation), AC	-40 °C ... 55 °C		
Ambient temperature (operation), DC	-40 °C ... 70 °C		
Mechanical service life, AC	1x 10 ⁷ cycles, approximately		
Mechanical service life, DC	1x 10 ⁷ cycles, approximately		
Standards/regulations	IEC 60664 , IEC 61810		

Ordering data

Description	Input voltage U_N	Type	Order No.	Pcs./ Pkt.
Bipolar, plug-in industrial relays , with power contacts	① 24 V DC	REL-IR4/24DC/4X21	2907054	10
	② 100 V AC	REL-IR4/100AC/4X21	2907055	10
	③ 200 V AC	REL-IR4/200AC/4X21	2907056	10

REL-IR2... (2-PDT)

Operating voltage range

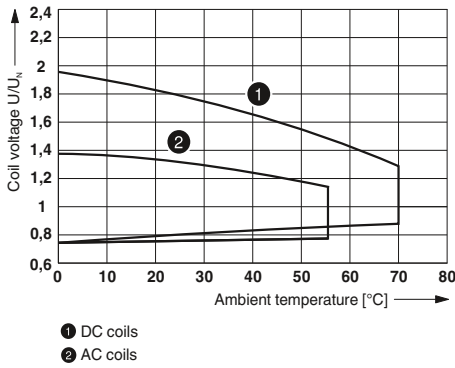

Interrupting rating

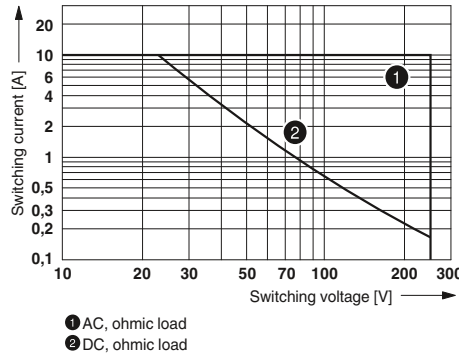

Electrical service life

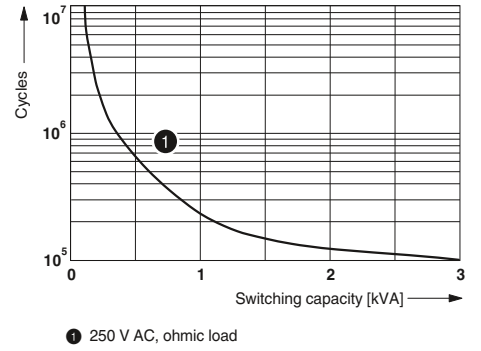

Service life reduction factor

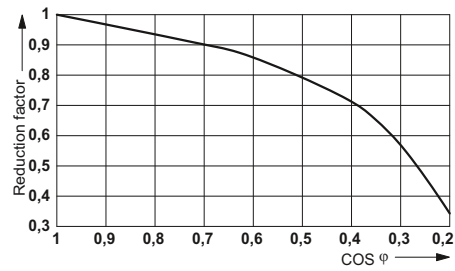

REL-IR4... (4-PDT)

Operating voltage range

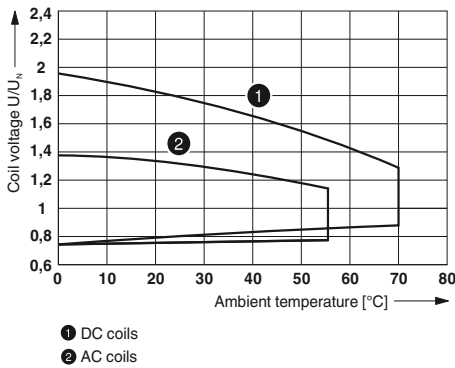

Interrupting rating

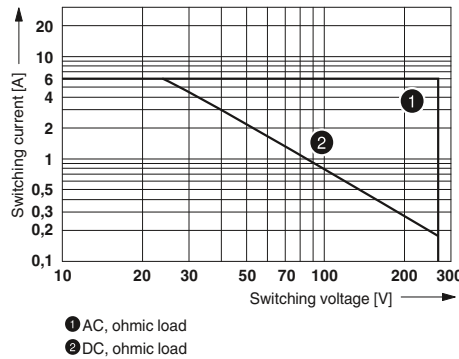

Electrical service life

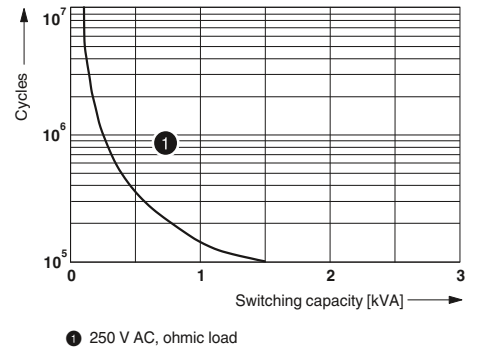

Service life reduction factor

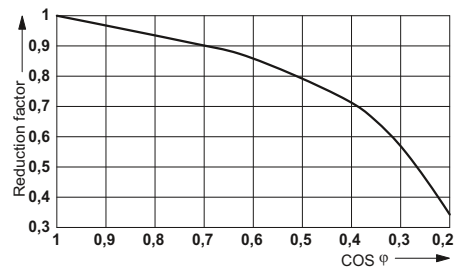

Relay modules

Industrial relay system - RIFLINE complete

Modular RIF-3 relay base

Relay base for assembly with 2 or 3-PDT relays.

Range of accessories includes:

- Plug-in interference suppression module
- Plug-in timer module
- Relay retaining bracket with ejector function and holder for marking material
- Comprehensive range of marking material
- Test plug
- FBS 2-6 plug-in bridges for the input side (A2)

Notes:
Type of insulating housing: Polyamide PA, non-reinforced, color: gray.
For further marking systems and mounting material, see Catalog 3.
When mounting relays on a DIN rail base or PCB, data may be limited, especially with regard to the limiting continuous current and/or ambient temperature range. See "General" section in "Basics of relay technology" on page 286.



2-PDT relay base with Push-in connection technology for octal relays



Nominal voltage U_N
Nominal current at U_N

General data
Ambient temperature (operation)
Connection data solid/stranded/AWG
Dimensions
Width
Depth with retaining bracket
Height

Technical data

250 V AC/DC
max. 12 A (Depends on application/assembly)

-40 °C ... 85 °C (Depends on application/assembly)

0.14 ... 1.5 mm² / 0.14 ... 1.5 mm² / 26 - 16

40 mm
90 mm
103 mm

Description
RIF-3 relay base , 2-PDT version, plug-in option for interference suppression module, safe isolation I/O with Push-in connection
RIF-3 relay base , 3-PDT version, plug-in option for interference suppression module, safe isolation I/O with Push-in connection
Plastic relay retaining bracket , with holder for marking material, suitable for RIF-3 relay base
Relay retaining bracket , wire model, suitable for RIF-3 relay base

Ordering data

Type	Order No.	Pcs./Pkt.
RIF-3-BPT/2X21	2900937	10

Plug-in bridge 2-pos. red, 32 A 2-pos. red, 24 A 2-pos. blue, 32 A 2-pos. gray, 32 A	
End bracket , for snapping onto NS 35, 9.5 mm wide, can be marked with ZB 6, ZB 8/27, KLM...	
Test plug , consisting of: Metal part for 2.3 mm Ø socket hole and	silver
Insulating sleeve , for MPS metal part	red white blue yellow green gray black
Zack marker strip , unprinted 10-section 5-section	
Double marker carrier for ZB 5	

Accessories

FBS 2-6	3030336	50
FBSR 2-6	3033715	50
FBS 2-6 BU	3036932	50
FBS 2-6 GY	3032237	50
CLIPFIX 35	3022218	50
MPS-MT	0201744	10
MPS-IH RD	0201676	10
MPS-IH WH	0201663	10
MPS-IH BU	0201689	10
MPS-IH YE	0201692	10
MPS-IH GN	0201702	10
MPS-IH GY	0201728	10
MPS-IH BK	0201731	10
ZB 5 :UNBEDRUCKT	1050004	10
ZB 15:UNBEDRUCKT	0811972	10
STP 5-2	0800967	100



3-PDT relay base with Push-in connection technology for octal relays



Plastic relay retaining bracket for RIF-3 base

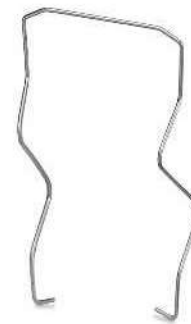

Metal wire relay retaining bracket for RIF-3 base



Technical data		
250 V AC/DC		
max. 12 A (Depends on application/assembly)		
-40 °C ... 85 °C (Depends on application/assembly)		
0.14 ... 1.5 mm ² / 0.14 ... 1.5 mm ² / 26 - 16		
40 mm		
90 mm		
103 mm		

Technical data		
-		
-		
-		
-		
-		
-		

Technical data		
-		
-		
-		
-		
-		
-		

Ordering data		
Type	Order No.	Pcs./Pkt.
RIF-3-BPT/3X21	2900938	10

Ordering data		
Type	Order No.	Pcs./Pkt.
RIF-RH-3	2900955	10

Ordering data		
Type	Order No.	Pcs./Pkt.
EL3-M52	2833628	10

Accessories		
Type	Order No.	Pcs./Pkt.
FBS 2-6	3030336	50
FBSR 2-6	3033715	50
FBS 2-6 BU	3036932	50
FBS 2-6 GY	3032237	50
CLIPFIX 35	3022218	50
MPS-MT	0201744	10
MPS-IH RD	0201676	10
MPS-IH WH	0201663	10
MPS-IH BU	0201689	10
MPS-IH YE	0201692	10
MPS-IH GN	0201702	10
MPS-IH GY	0201728	10
MPS-IH BK	0201731	10
ZB 5 :UNBEDRUCKT	1050004	10
ZB 15:UNBEDRUCKT	0811972	10
STP 5-2	0800967	100

Accessories		
Type	Order No.	Pcs./Pkt.

Accessories		
Type	Order No.	Pcs./Pkt.

Relay modules

Industrial relay system - RIFLINE complete

Modular RIF-3 relay base

Relay base for assembly with 2 or 3-PDT octal relay.

Range of accessories includes:

- Plug-in interference suppression module
- Plug-in timer module
- Relay retaining bracket with ejector function and holder for marking material
- Comprehensive range of marking material
- Test plug
- FBS 2-6 plug-in bridges for the input side (A2)

Notes:
Type of insulating housing: Polyamide PA, non-reinforced, color: gray.
For further marking systems and mounting material, see Catalog 3.
When mounting relays on a DIN rail base or PCB, data may be limited, especially with regard to the limiting continuous current and/or ambient temperature range. See "General" section in "Basics of relay technology" on page 286.

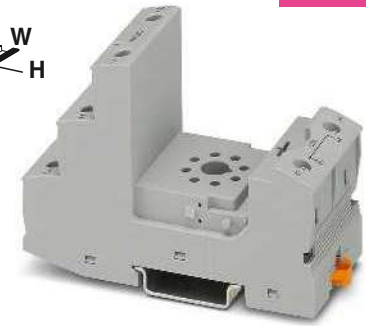

new

2-PDT relay base with screw connection technology for octal relays

Nominal voltage U_N
Nominal current at U_N

250 V AC/DC
max. 12.5 A (Depends on application/assembly)

General data
Ambient temperature (operation)

-40 °C ... 85 °C (Depends on application/assembly)

Connection data solid/stranded/AWG
Dimensions
Width
Depth with retaining bracket
Height

0.14 ... 6 mm² / 0.14 ... 4 mm² / 26 - 10
40 mm
90 mm
96 mm

Description
RIF-3 relay base , 2-PDT version, plug-in option for interference suppression module, safe isolation I/O with screw connection
RIF-3 relay base , 3-PDT version, plug-in option for interference suppression module, safe isolation I/O with screw connection
Plastic relay retaining bracket , with holder for marking material, suitable for RIF-3 relay base
Relay retaining bracket , wire model, suitable for RIF-3 relay base

Ordering data		
Type	Order No.	Pcs./Pkt.
RIF-3-BSC/2X21	2900935	10

Plug-in bridge 2-pos. red, 32 A 2-pos. red, 24 A 2-pos. blue, 32 A 2-pos. gray, 32 A	
End bracket , for snapping onto NS 35, 9.5 mm wide, can be marked with ZB 6, ZB 8/27, KLM...	
Test plug , consisting of: Metal part for 2.3 mm Ø socket hole and	silver
Insulating sleeve , for MPS metal part	red white blue yellow green gray black
Zack marker strip , unprinted 10-section 5-section	
Double marker carrier for ZB 5	

Accessories		
Type	Order No.	Pcs./Pkt.
FBS 2-6	3030336	50
FBSR 2-6	3033715	50
FBS 2-6 BU	3036932	50
FBS 2-6 GY	3032237	50
CLIPFIX 35	3022218	50
MPS-MT	0201744	10
MPS-IH RD	0201676	10
MPS-IH WH	0201663	10
MPS-IH BU	0201689	10
MPS-IH YE	0201692	10
MPS-IH GN	0201702	10
MPS-IH GY	0201728	10
MPS-IH BK	0201731	10
ZB 5 :UNBEDRUCKT	1050004	10
ZB 15:UNBEDRUCKT	0811972	10
STP 5-2	0800967	100



new

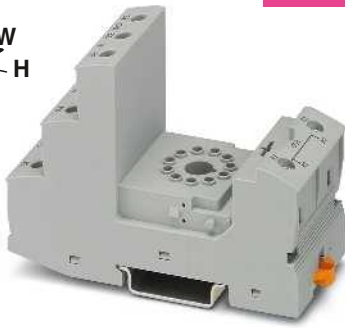

3-PDT relay base with screw connection technology for octal relays



Plastic relay retaining bracket for RIF-3 base

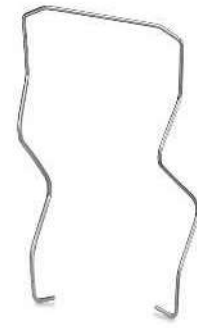

Metal wire relay retaining bracket for RIF-3 base



Technical data			Technical data			Technical data		
250 V AC/DC max. 10.5 A (Depends on application/assembly)			-			-		
-40 °C ... 85 °C (Depends on application/assembly)			-			-		
0.14 ... 6 mm ² / 0.14 ... 4 mm ² / 26 - 10			-			-		
40 mm			-			-		
90 mm			-			-		
96 mm			-			-		
Ordering data			Ordering data			Ordering data		
Type	Order No.	Pcs./ Pkt.	Type	Order No.	Pcs./ Pkt.	Type	Order No.	Pcs./ Pkt.
RIF-3-BSC/3X21	2900936	10						
			RIF-RH-3	2900955	10			
						EL3-M52	2833628	10
Accessories			Accessories			Accessories		
FBS 2-6	3030336	50						
FBSR 2-6	3033715	50						
FBS 2-6 BU	3036932	50						
FBS 2-6 GY	3032237	50						
CLIPFIX 35	3022218	50						
MPS-MT	0201744	10						
MPS-IH RD	0201676	10						
MPS-IH WH	0201663	10						
MPS-IH BU	0201689	10						
MPS-IH YE	0201692	10						
MPS-IH GN	0201702	10						
MPS-IH GY	0201728	10						
MPS-IH BK	0201731	10						
ZB 5 :UNBEDRUCKT	1050004	10						
ZB 15:UNBEDRUCKT	0811972	10						
STP 5-2	0800967	100						

Relay modules

Industrial relay system - RIFLINE complete

Plug-in octal relays

Plug-in octal relays with 2 or 3 changeover contacts, suitable for RIF-3 relay base.

The advantages:

- With detectable manual operation
- Mechanical switch position indicator
- Integrated status LED
- DC types with integrated freewheeling diode

Notes:

When mounting relays on a DIN rail base or PCB, data may be limited, especially with regard to the limiting continuous current and/or ambient temperature range. See "General" section in "Basics of relay technology" on page 286.



2-PDT octal relay with manual operation, max. 2 x 10 A



3-PDT octal relay with manual operation, max. 3 x 10 A

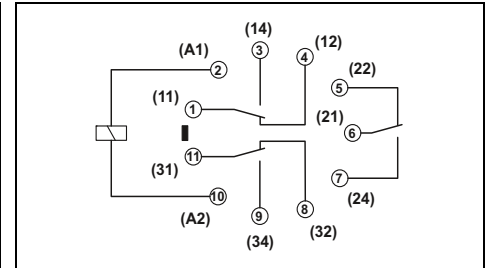
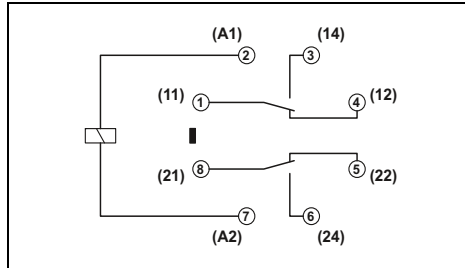

Technical data

Input data	①	④	⑤	⑥	⑦	
Permissible range (with reference to U_N)	see diagram					
Typical input current at U_N	[mA]	60	8	108	23	13
Typical response time at U_N	[ms]	18	18			
Typical response time at U_N (depending on phase relation)	[ms]			5 - 15	5 - 15	5 - 15
Typical release time at U_N	[ms]	20	7			
Typical release time at U_N (depending on phase relation)	[ms]			5 - 20	5 - 20	5 - 20

Technical data

Input data	①	②	③	④	⑤	⑥	⑦
Permissible range (with reference to U_N)	see diagram						
Typical input current at U_N	[mA]	60		8	108	23	13
Typical response time at U_N	[ms]	18	18	18	18		
Typical response time at U_N (depending on phase relation)	[ms]				5 - 15	5 - 15	5 - 15
Typical release time at U_N	[ms]	20	20	20	7		
Typical release time at U_N (depending on phase relation)	[ms]				5 - 20	5 - 20	5 - 20

Output data					
Contact type	2 PDT				
Contact material	AgNi				
Max. switching voltage	250 V AC/DC				
Minimum switching voltage	10 V (At 24 mA)				
Limiting continuous current	10 A				
Maximum switch-on current AC	30 A (20 ms, N/O contact)				
Maximum switch-on current DC	30 A (20 ms, N/O contact)				
Minimum switching current	10 mA (at 24 V)				
General data					
Test voltage (winding / contact)	2.5 kV _{rms} (50 Hz, 1 min.)				
Ambient temperature (operation), AC	-40 °C ... 55 °C				
Ambient temperature (operation), DC	-40 °C ... 70 °C				
Nominal operating mode	100% operating factor				
Mechanical service life, AC	Approx. 2x 10 ⁷ cycles				
Mechanical service life, DC	Approx. 2x 10 ⁷ cycles				
Standards/regulations	IEC 60664 , IEC 61810				
Mounting position/mounting	any				
Dimensions	W / H / D 35 mm / 54.4 mm / 35 mm				

Output data							
Contact type	3 PDT						
Contact material	AgNi						
Max. switching voltage	250 V AC/DC						
Minimum switching voltage	10 V (At 24 mA)						
Limiting continuous current	10 A						
Maximum switch-on current AC	30 A (20 ms, N/O contact)						
Maximum switch-on current DC	30 A (20 ms, N/O contact)						
Minimum switching current	10 mA (at 24 V)						
General data							
Test voltage (winding / contact)	2.5 kV _{rms} (50 Hz, 1 min.)						
Ambient temperature (operation), AC	-40 °C ... 55 °C						
Ambient temperature (operation), DC	-40 °C ... 70 °C						
Nominal operating mode	100% operating factor						
Mechanical service life, AC	Approx. 2x 10 ⁷ cycles						
Mechanical service life, DC	Approx. 2x 10 ⁷ cycles						
Standards/regulations	IEC 60664 , IEC 61810						
Mounting position/mounting	any						
Dimensions	35 mm / 54.4 mm / 35 mm						

Ordering data

Description	Input voltage U_N	Type	Order No.	Pcs./ Pkt.
Plug-in octal relays, with power contacts				
With freewheeling diode	① 24 V DC	REL-OR2/LDP- 24DC/2X21	2903689	10
	② 48 V DC			
	③ 110 V DC			
	④ 220 V DC	REL-OR2/LDP-220DC/2X21	2907026	10
	⑤ 24 V AC	REL-OR2/L- 24AC/2X21	2903690	10
	⑥ 120 V AC	REL-OR2/L-120AC/2X21	2903691	10
	⑦ 230 V AC	REL-OR2/L-230AC/2X21	2903692	10

Ordering data

Type	Order No.	Pcs./ Pkt.
REL-OR3/LDP-24DC/3X21	2903693	10
REL-OR3/LDP-48DC/3X21	2908897	10
REL-OR3/LDP-110DC/3X21	2908898	10
REL-OR3/LDP-220DC/3X21	2907027	10
REL-OR3/L- 24AC/3X21	2903694	10
REL-OR3/L-120AC/3X21	2903695	10
REL-OR3/L-230AC/3X21	2903696	10

REL-OR2... (2-PDT)

Operating voltage range

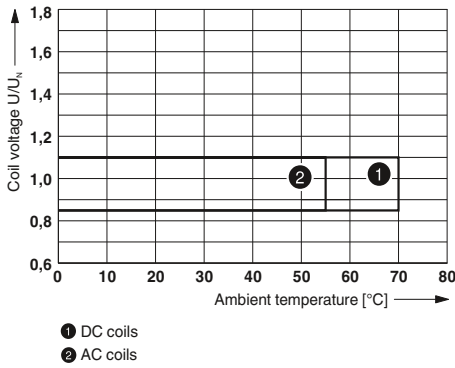

Interrupting rating

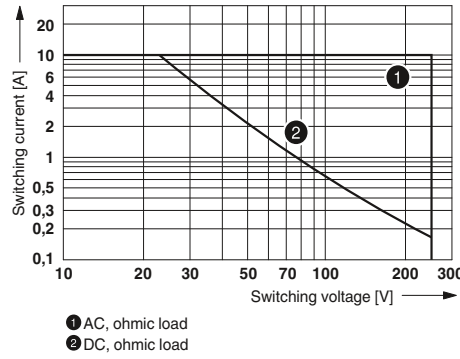

Electrical service life

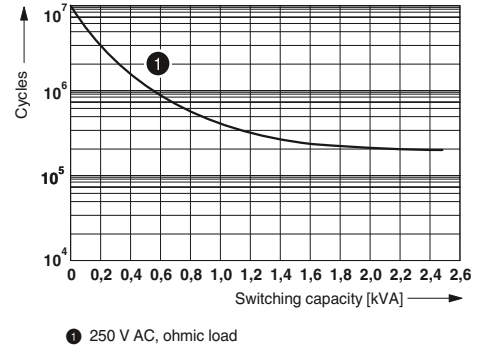

Service life reduction factor

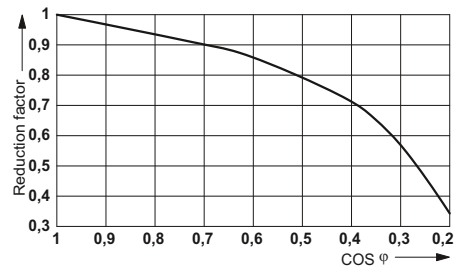

REL-OR3... (3-PDT)

Operating voltage range

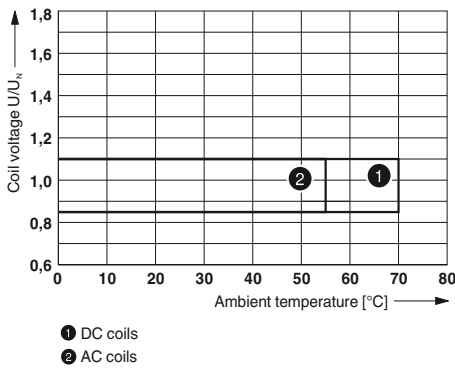

Interrupting rating

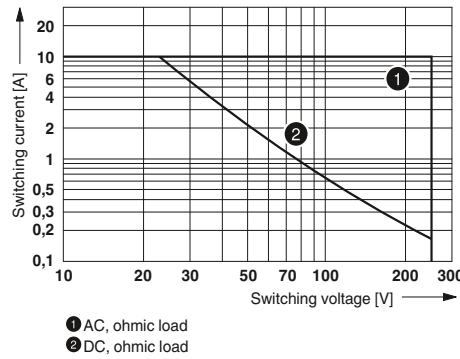

Electrical service life

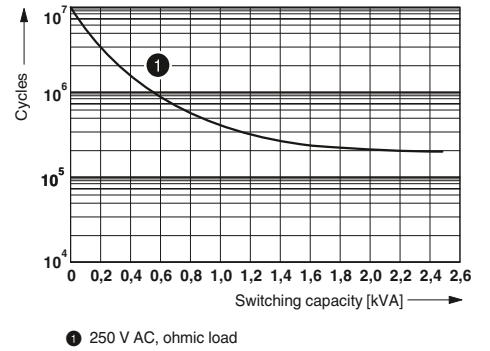

Service life reduction factor

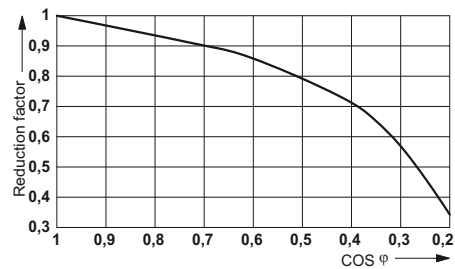

Relay modules

Industrial relay system - RIFLINE complete

Modular RIF-4 relay base

Relay base for assembly with 2 or 3-PDT relays or 3-N/O relays.

Range of accessories includes:

- Plug-in interference suppression module
- Plug-in timer module
- Relay retaining bracket with ejector function and holder for marking material
- Comprehensive range of marking material
- Test plug
- FBS 2-6 plug-in bridges for the input side (A2)

Notes:
Type of insulating housing: Polyamide PA, non-reinforced, color: gray.
For further marking systems and mounting material, see Catalog 3.
When mounting relays on a DIN rail base or PCB, data may be limited, especially with regard to the limiting continuous current and/or ambient temperature range. See "General" section in "Basics of relay technology" on page 286.



3-PDT relay base with Push-in connection technology for high-power relays



Nominal voltage U_N
Nominal current at U_N

440 V AC
max. 16 A (Depends on application/assembly)

General data
Ambient temperature (operation)

-40 °C ... 85 °C (Depends on application/assembly)

Connection data solid/stranded/AWG
Input side
Output side
Dimensions
Width
Depth with retaining bracket
Height

0.14 ... 1.5 mm² / 0.14 ... 1.5 mm² / 26 - 16
0.14 ... 2.5 mm² / 0.14 ... 2.5 mm² / 26 - 14
43 mm
90 mm
111 mm

Description

RIF-4 relay base, plug-in option for interference suppression module, safe isolation I/O with Push-in connection

RIF-4 relay base, plug-in option for interference suppression module, safe isolation I/O with screw connection

Relay retaining bracket, with holder for marking material, suitable for RIF-4 relay base

Relay retaining bracket, wire model, suitable for RIF-4 relay base

Ordering data

Type	Order No.	Pcs./Pkt.
RIF-4-BPT/3X21	2900961	10

Plug-in bridge

2-pos. red, 32 A
2-pos. red, 24 A
2-pos. blue, 32 A
2-pos. gray, 32 A

End bracket, for snapping onto NS 35, 9.5 mm wide, can be marked with ZB 6, ZB 8/27, KLM...

Test plug, consisting of:

Metal part for 2.3 mm Ø socket hole and silver

Insulating sleeve, for MPS metal part

red
white
blue
yellow
green
gray
black

Zack marker strip, unprinted

10-section
5-section

Double marker carrier for ZB 5

Accessories

FBS 2-6	3030336	50
FBSR 2-6	3033715	50
FBS 2-6 BU	3036932	50
FBS 2-6 GY	3032237	50
CLIPFIX 35	3022218	50
MPS-MT	0201744	10
MPS-IH RD	0201676	10
MPS-IH WH	0201663	10
MPS-IH BU	0201689	10
MPS-IH YE	0201692	10
MPS-IH GN	0201702	10
MPS-IH GY	0201728	10
MPS-IH BK	0201731	10
ZB 5 :UNBEDRUCKT	1050004	10
ZB 15:UNBEDRUCKT	0811972	10
STP 5-2	0800967	100

new

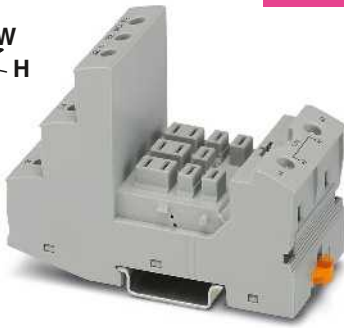

3-PDT relay base with screw connection technology for high-power relays



Plastic relay retaining bracket for RIF-4 base



Metal wire relay retaining bracket for RIF-4 base



Technical data
440 V AC max. 13 A (Depends on application/assembly)
-40 °C ... 85 °C (Depends on application/assembly)
0.14 ... 6 mm ² / 0.14 ... 4 mm ² / 26 - 10 0.14 ... 6 mm ² / 0.14 ... 4 mm ² / 26 - 10
44 mm 91 mm 96 mm

Technical data
-
-
-
-
-
-

Technical data
-
-
-
-
-
-

Ordering data		
Type	Order No.	Pcs./ Pkt.
RIF-4-BSC/3X21	2900960	10

Ordering data		
Type	Order No.	Pcs./ Pkt.
RIF-RH-4	2900956	10

Ordering data		
Type	Order No.	Pcs./ Pkt.
RIF-RHM-4	2905983	10

Accessories		

Accessories		

Accessories		

Relay modules

Industrial relay system - RIFLINE complete

Plug-in high-power relays

Plug-in high-power relays with 2 or 3 changeover contacts for the RIF-4 relay base.

The advantages:

- Use in miniature contactor applications
- Switching current of up to 16 A
- Up to 440 V AC switching voltage

Notes:
When mounting relays on a DIN rail base or PCB, data may be limited, especially with regard to the limiting continuous current and/or ambient temperature range. See "General" section in "Basics of relay technology" on page 286.



2-PDT high-power relay, max. 2 x 16 A



3-PDT high-power relay, max. 3 x 16 A

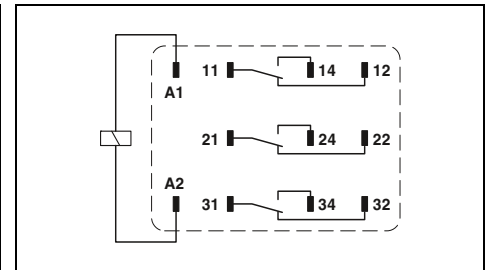
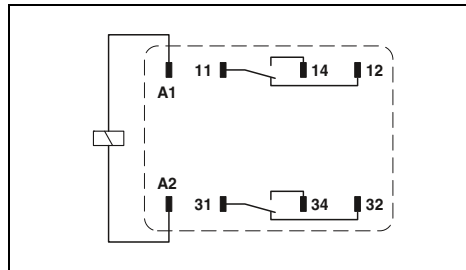

Technical data

Input data	①	②	③	④
Permissible range (with reference to U_N)	see diagram			
Typical input current at U_N [mA]	56	116	23	12
Typical response time at U_N [ms]	20			
Typical response time at U_N (depending on phase relation) [ms]		5 - 25	5 - 25	5 - 25
Typical release time at U_N [ms]	15			
Typical release time at U_N (depending on phase relation) [ms]		5 - 20	5 - 20	5 - 20
Output data				
Contact type	2 PDT			
Contact material	AgNi			
Max. switching voltage	440 V AC / 250 V DC			
Minimum switching voltage	10 V (At 24 mA)			
Limiting continuous current	16 A			
Maximum switch-on current AC	50 A (20 ms, N/O contact)			
Maximum switch-on current DC	50 A (20 ms, N/O contact)			
Minimum switching current	10 mA (at 24 V)			
Maximum interrupting rating, ohmic load	250 V AC	4000 VA		
	440 V AC	4000 VA		
Motor load according to UL 508		1/3 HP, 120 V AC (single-phase AC motor)		
		1/2 HP, 240 V AC (single-phase AC motor)		

Technical data	①	②	③	④	⑤
Permissible range (with reference to U_N)	see diagram				
Typical input current at U_N [mA]	56		116	23	12
Typical response time at U_N [ms]	20	20			
Typical response time at U_N (depending on phase relation) [ms]			5 - 25	5 - 25	5 - 25
Typical release time at U_N [ms]	15	15			
Typical release time at U_N (depending on phase relation) [ms]			5 - 20	5 - 20	5 - 20
Output data					
Contact type	3 PDT				
Contact material	AgNi				
Max. switching voltage	440 V AC / 250 V DC				
Minimum switching voltage	10 V (At 24 mA)				
Limiting continuous current	16 A				
Maximum switch-on current AC	50 A (20 ms, N/O contact)				
Maximum switch-on current DC	50 A (20 ms, N/O contact)				
Minimum switching current	10 mA (at 24 V)				
Maximum interrupting rating, ohmic load	4000 VA				
	4000 VA				
Motor load according to UL 508			1/3 HP, 120 V AC (single-phase AC motor)		
			1/2 HP, 240 V AC (single-phase AC motor)		
			1/2 HP, 240 V AC (three-phase induction motor)		

General data	W / H / D
Test voltage (winding / contact)	38.6 mm / 45.5 mm / 36.1 mm
Ambient temperature (operation), AC	
Ambient temperature (operation), DC	
Nominal operating mode	
Mechanical service life, AC	
Mechanical service life, DC	
Standards/regulations	
Mounting position/mounting	
Dimensions	

Test voltage (winding / contact)	2.5 kV _{rms} (50 Hz, 1 min.)
Ambient temperature (operation), AC	-40 °C ... 55 °C
Ambient temperature (operation), DC	-40 °C ... 70 °C
Nominal operating mode	100% operating factor
Mechanical service life, AC	Approx. 10 ⁷ cycles
Mechanical service life, DC	Approx. 10 ⁷ cycles
Standards/regulations	IEC 60664, IEC 61810
Mounting position/mounting	any
Dimensions	38.6 mm / 45.5 mm / 36.1 mm

Ordering data

Description	Input voltage U_N
Plug-in high-power relays, 2 changeover contacts with power contacts	① 24 V DC
	② 24 V AC
	③ 120 V AC
	④ 230 V AC
Plug-in high-power relays, 3 changeover contacts with power contacts	① 24 V DC
	② 110 V DC
	③ 24 V AC
	④ 120 V AC
	⑤ 230 V AC

Type	Order No.	Pcs./ Pkt.
REL-PR2- 24DC/2X21	2903698	1
REL-PR2- 24AC/2X21	2903699	1
REL-PR2-120AC/2X21	2903700	1
REL-PR2-230AC/2X21	2903701	1

Ordering data

Type	Order No.	Pcs./ Pkt.
REL-PR3- 24DC/3X21	2903702	1
REL-PR3-110DC/3X21	2908893	1
REL-PR3- 24AC/3X21	2903703	1
REL-PR3-120AC/3X21	2903704	1
REL-PR3-230AC/3X21	2903705	1

REL-PR2... (2-PDT)

Operating voltage range

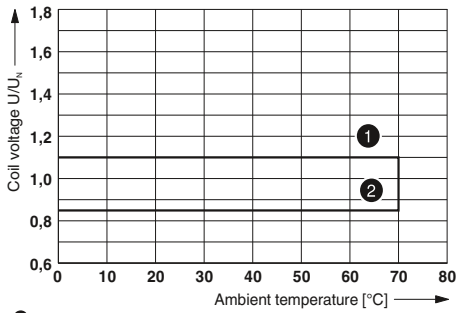

- 1 Maximum continuous voltage at limiting continuous current = 16 A
 - 2 Minimum operate voltage
- For pre-excitation with UN and limiting continuous current = 16 A

Interrupting rating

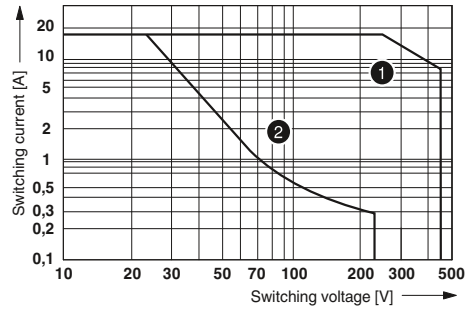

- 1 AC, ohmic load
- 2 DC, ohmic load

Electrical service life

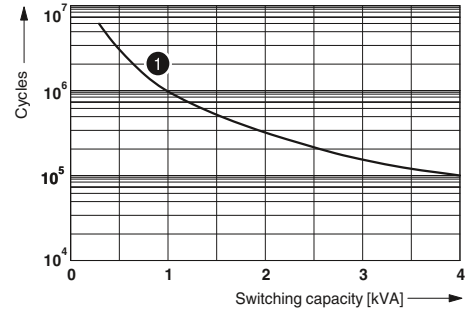

- 1 250 V AC, ohmic load

Service life reduction factor

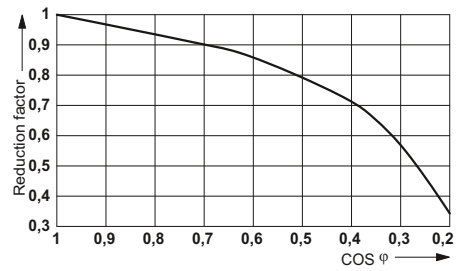

REL-PR3... (3-PDT)

Operating voltage range

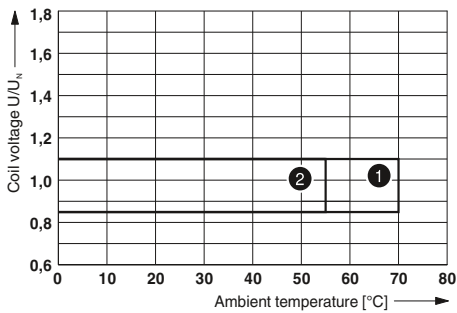

- 1 DC coils
- 2 AC coils

Interrupting rating

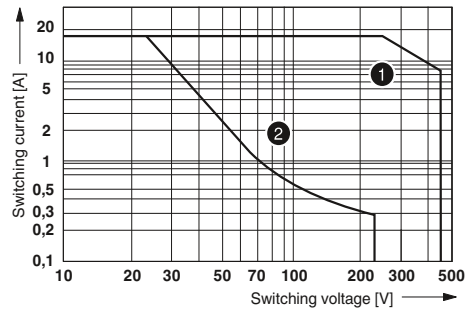

- 1 AC, ohmic load
- 2 DC, ohmic load

Electrical service life

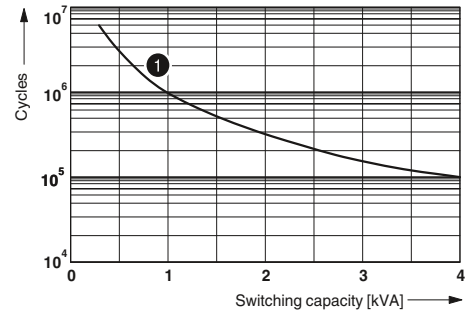

- 1 250 V AC, ohmic load

Service life reduction factor

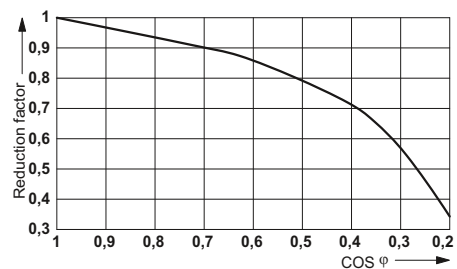

Relay modules

Industrial relay system - RIFLINE complete

Plug-in high-power relays

Plug-in high-power relays with 3 N/O contacts suitable for the RIF-4 relay base.

The advantages:

- Use in miniature contactor applications
- Switching current of up to 16 A
- Up to 440 V AC switching voltage
- Full shutdown by means of ≥ 3 mm contact opening

Notes:
When mounting relays on a DIN rail base or PCB, data may be limited, especially with regard to the limiting continuous current and/or ambient temperature range. See "General" section in "Basics of relay technology" on page 286.



3-N/O high-power relay, max. 3 x 16 A



new

1-N/O high-power relay with blowout magnet for switching high DC loads

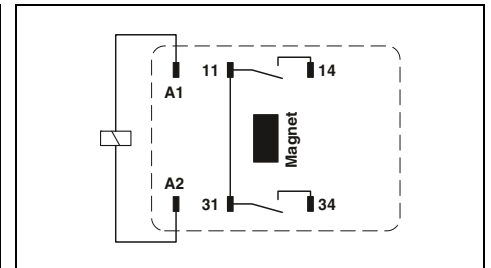
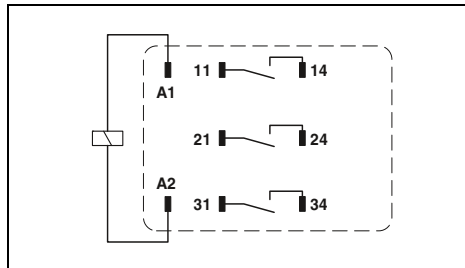

Technical data

Input data	①	②	③	④
Permissible range (with reference to U_N)	see diagram			
Typical input current at U_N	70	116	23	12
Typical response time at U_N	20			
Typical response time at U_N (depending on phase relation)		5 - 25	5 - 25	5 - 25
Typical release time at U_N	15			
Typical release time at U_N (depending on phase relation)		5 - 20	5 - 20	5 - 20
Output data				
Contact type	3 N/O contacts			
Contact material	AgNi			
Max. switching voltage	440 V AC / 250 V DC			
Minimum switching voltage	10 V (At 24 mA)			
Limiting continuous current	16 A			
Maximum switch-on current AC	50 A (20 ms, N/O contact)			
Maximum switch-on current DC	50 A (20 ms, N/O contact)			
Minimum switching current	10 mA (at 24 V)			
Maximum interrupting rating, ohmic load	250 V AC	4000 VA		
	440 V AC	4000 VA		
Motor load according to UL 508		1/3 HP, 120 V AC (single-phase AC motor)		
		1/2 HP, 240 V AC (single-phase AC motor)		
		1/2 HP, 240 V AC (three-phase induction motor)		

Technical data	①	②	③	④
Permissible range (with reference to U_N)	see diagram			
Typical input current at U_N	70	15	7.3	12
Typical response time at U_N	20	20	20	
Typical response time at U_N (depending on phase relation)				5 - 25
Typical release time at U_N	15	15	15	
Typical release time at U_N (depending on phase relation)				5 - 18
Output data				
Contact type	1 N/O contact			
Contact material	AgNi			
Max. switching voltage	440 V AC / 350 V DC			
Minimum switching voltage	5 V (At 24 mA)			
Limiting continuous current	16 A			
Maximum switch-on current AC	50 A (20 ms)			
Maximum switch-on current DC	50 A (20 ms)			
Minimum switching current	5 mA (at 24 V)			
Maximum interrupting rating, ohmic load	4000 VA			
	-			
Motor load according to UL 508				

General data	
Test voltage (winding / contact)	2.5 kV _{rms} (50 Hz, 1 min.)
Ambient temperature (operation), AC	-40 °C ... 55 °C
Ambient temperature (operation), DC	-40 °C ... 70 °C
Nominal operating mode	100% operating factor
Mechanical service life, AC	Approx. 10 ⁷ cycles
Mechanical service life, DC	Approx. 10 ⁷ cycles
Standards/regulations	IEC 60664, IEC 61810
Mounting position/mounting	any
Dimensions	W / H / D 38.6 mm / 45.5 mm / 36.1 mm

General data	
Test voltage (winding / contact)	2.5 kV
Ambient temperature (operation), AC	-40 °C ... 70 °C
Ambient temperature (operation), DC	-40 °C ... 70 °C
Nominal operating mode	100% operating factor
Mechanical service life, AC	Approx. 2x 10 ⁷ cycles
Mechanical service life, DC	Approx. 2x 10 ⁷ cycles
Standards/regulations	IEC 60664, IEC 61810
Mounting position/mounting	any
Dimensions	38.6 mm / 45.5 mm / 36.1 mm

Ordering data

Description	Input voltage U_N
Plug-in high-power relays, 3 N/O contacts with power contacts	
	① 24 V DC
	② 24 V AC
	③ 120 V AC
	④ 230 V AC
Plug-in high-power relays, 1 N/O contact with blow magnet and power contacts	
	① 24 V DC
	② 110 V DC
	③ 220 V DC
	④ 230 V AC

Type	Order No.	Pcs./Pkt.
REL-PR3-24DC/3X1	2903706	1
REL-PR3-24AC/3X1	2903707	1
REL-PR3-120AC/3X1	2903708	1
REL-PR3-230AC/3X1	2903709	1

Ordering data

Type	Order No.	Pcs./Pkt.
REL-PR1-24DC/1/MB	2908040	1
REL-PR1-110DC/1/MB	2908044	1
REL-PR1-220DC/1/MB	2908046	1
REL-PR1-230AC/1/MB	2908047	1

REL-PR3... (3 N/O contacts)

Operating voltage range

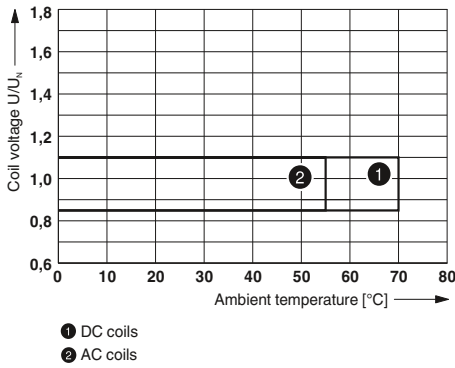

Interrupting rating

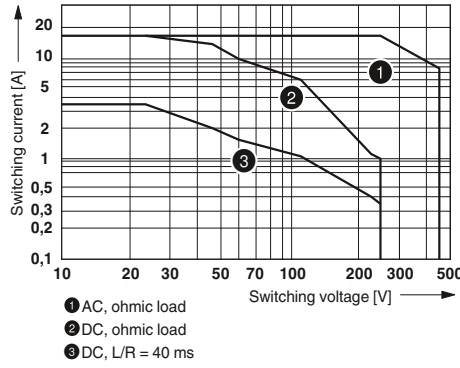

Electrical service life

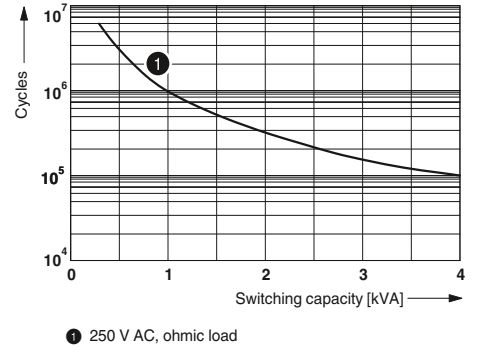

Service life reduction factor

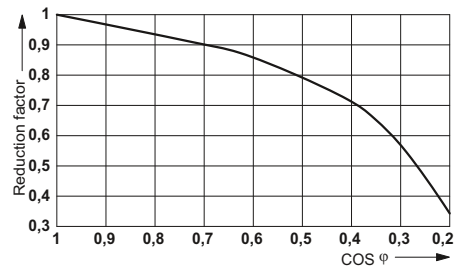

REL-PR1... (1 N/O contact with blow magnet)

Interrupting rating

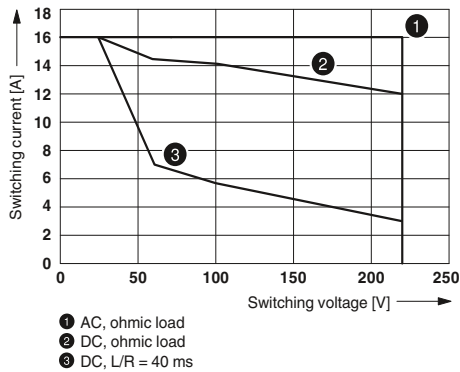

Industrial relay system - RIFLINE complete

Plug-in interference suppression modules for RIF-1, RIF-2, RIF-3, and RIF-4

Plug-in interference suppression modules for optional assembly of RIF-1 to RIF-4 relay bases.

The advantages:

- Attenuation of reverse voltage induced in coil
- Mechanical coding to protect against incorrect connection



Interference suppression modules for RIF-1 to RIF-4



Ordering data

Description	Type	Order No.	Pcs./Pkt.
Plug-in module, with LED status indicator and freewheeling diode to effectively limit the coil induction voltage, polarity: A1+ , A2- , input voltage: - 12-24 V DC $\pm 20\%$ - 48-60 V DC $\pm 20\%$ - 110 V DC $\pm 20\%$	RIF-LDP-12-24 DC RIF-LDP-48-60 DC RIF-LDP-110 DC	2900939 2900940 2900941	10 10 10
Plug-in module, with LED status indicator and varistor to limit the coil induction voltage and/or external interference peaks, input voltage: - 12-24 V AC/DC $\pm 20\%$ (30 V varistor) - 48-60 V AC/DC $\pm 20\%$ (75 V varistor) - 120-230 V AC/110 V DC $\pm 20\%$ (275 V varistor)	RIF-LV-12-24 UC RIF-LV-48-60 UC RIF-LV-120-230 AC/110 DC	2900942 2900943 2900944	10 10 10
Plug-in module, with varistor to limit the coil induction voltage and/or external interference peaks, input voltage: - 12-24 V AC/DC $\pm 20\%$ (30 V varistor) - 48-60 V AC/DC $\pm 20\%$ (75 V varistor) - 120-230 V AC/DC $\pm 20\%$ (275 V varistor)	RIF-V-12-24 UC RIF-V-48-60 UC RIF-V-120-230 UC	2900945 2900947 2900948	10 10 10
Plug-in module, with RC element to limit the coil induction voltage and/or external interference peaks, input voltage: - 12-24 V AC/DC $\pm 20\%$ (220 nF/100 Ω) - 48-60 V AC/DC $\pm 20\%$ (220 nF/220 Ω) - 120 - 230 V AC/DC $\pm 20\%$ (100 nF/470 Ω)	RIF-RC-12-24 UC RIF-RC-48-60 UC RIF-RC-120-230 UC	2900949 2900950 2900951	10 10 10
Plug-in module, with bridge rectifier for controlling electromechanical DC voltage relay, Input voltage: - 12 ... 230 V AC	RIF-BR-12-230 AC	2907060	10
Plug-in module, with LED status indicator and freewheeling diode to effectively limit the coil induction voltage, polarity: A1- , A2+ , Input voltage: - 12-24 V DC $\pm 20\%$	RIF-LDM-12-24 DC	2907057	10
Plug-in module, with LED status indicator and varistor to limit the coil induction voltage and/or external interference peaks, polarity A1- , A2+ , Input voltage: - 120-230 V AC/110 V DC $\pm 20\%$ (275 V varistor)	RIF-LVM-100-200 AC/110 DC	2907058	10

Plug-in timer module for RIF-1, RIF-2, RIF-3, and RIF-4

The multifunctional plug-in timer module transforms a relay module into a time relay. RIF-1 to RIF-4 bases can be equipped with this module. Using DIP switches, three time functions and four time ranges can be selected. Detailed time settings are made using a potentiometer. Relays can be operated with an input voltage of 12 or 24 V AC/DC.

The time functions:

- With switch-on delay
- With passing make contact
- Pulse generator

Time ranges:

- 0.5 to 10 s
- 5 to 100 s
- 0.5 to 10 min
- 5 to 100 min



Timer module for RIF-1 to RIF-4 relay modules for 12 to 24 V AC/DC input voltage

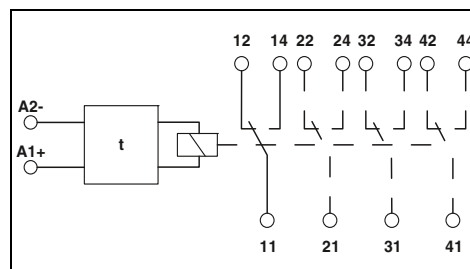

With switch-on delay

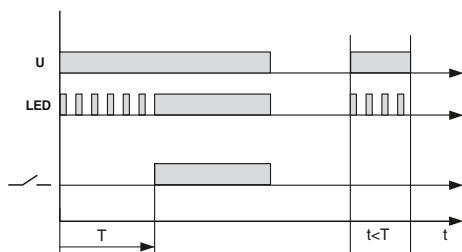

Passing make contact

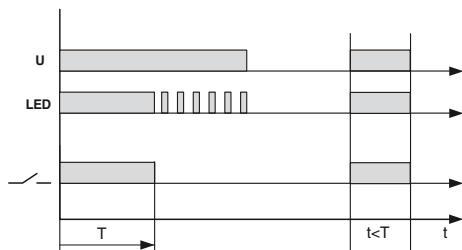

Pulse generator

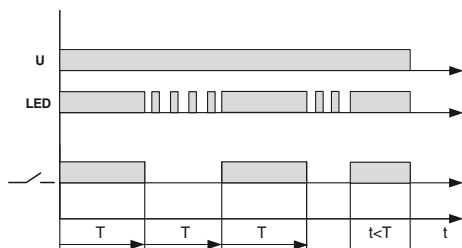

Input data
Nominal input voltage U_N
Nominal input voltage range with reference to U_N
Input circuit
Output data
Limiting continuous current
General data
Mounting position
Repeat accuracy
Ambient temperature (operation)
Standards/specifications
Rated insulation voltage
Rated surge voltage

Technical data
24 V DC (AC operation only permitted for RIF-1)
0.4 ... 1.2
Varistor, Yellow LED
≤ 250 mA (Relay coil current)
any
1 %
-25 °C ... 50 °C (RIF-1, AC coil, 2 PDTs at 6 A)
-25 °C ... 50 °C (RIF-1, DC coil, 2 PDTs at 5 A)
-25 °C ... 40 °C (RIF-2, DC coil, 2 PDTs at 8 A)
-25 °C ... 40 °C (RIF-2, DC coil, 4 PDTs at 5 A)
-25 °C ... 40 °C (RIF-3, DC coil, 3 PDTs at 6.75 A)
-25 °C ... 40 °C (RIF-3, DC coil, 2 PDTs at 8 A)
-25 °C ... 35 °C (RIF-4, DC coil, 3 PDTs at 8 A)
-25 °C ... 25 °C (RIF-4, DC coil, 3 N/O contacts at 8 A)
DIN EN 50178
50 V DC
0.4 kV

Description
Timer module , for mounting on RIF-1 to RIF-4, with LED status indicator for extending a relay module to create a time relay with an input voltage of 24 V AC/DC

Ordering data		
Type	Order No.	Pcs./Pkt.
RIF-T3-24UC	2902647	1

Relay modules

Industrial relay system - RIFLINE complete

Fully mounted RIF-0 relay modules

Fully mounted RIF-0 relay modules, consisting of:

- Relay base with Push-in connection
- 1-N/O or 1-PDT relay
- Relay ejector lever on the housing

The advantages:

- Status LED integrated in the relay base
- Operational reliability thanks to sealed relay
- Safe isolation between coil and contact side
- Professional bridging of adjacent modules saves wiring time
- For FBS 2-6 plug-in bridges for the input and output side, see page 366.

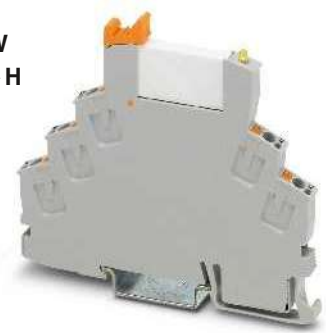

1-PDT relay module with Push-in connection

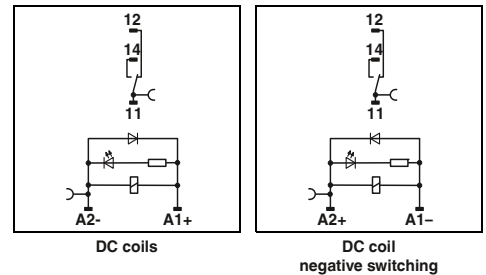

DC coils

DC coil negative switching

Technical data

Input data	①	②
Permissible range (with reference to U_N)	see diagram	
Typical input current at U_N [mA]	16	9
Typical response time at U_N [ms]	5	5
Typical release time at U_N [ms]	8	8
Input protection:	Yellow LED, Damping diode	
Output data		
Contact type	1 PDT	1 PDT
Contact material	AgSnO	AgSnO, hard gold-plated
Max. switching voltage	250 V AC/DC	30 V AC / 36 V DC
Minimum switching voltage	5 V (at 100 mA)	100 mV (at 10 mA)
Limiting continuous current	6 A	50 mA
Minimum switching current	10 mA (at 12 V)	1 mA
General data		
Test voltage (winding / contact)	4 kV _{rms} (50 Hz, 1 min.)	
Ambient temperature (operation)	-40 °C ... 60 °C	
Nominal operating mode	100% operating factor	
Mechanical service life	Approx. 2x 10 ⁷ cycles	
Standards/regulations	DIN EN 50178	
Degree of pollution/surge voltage category	2 / III	
Mounting position/mounting	any / In rows with zero spacing	
Connection data solid/stranded/AWG	0.14 ... 1.5 mm ² / 0.14 ... 1.5 mm ² / 26 - 16	
Dimensions	W / H / D 6.2 mm / 93 mm / 78 mm	
EMC note	Class A product, see page 605	

Ordering data

Description	Input voltage U_N	Type	Order No.	Pcs./Pkt.
Coupling relay modules with power contact relay and Push-in connection	① 12 V DC	RIF-0-RPT-12DC/21	2903371	10
	② 24 V DC	RIF-0-RPT-24DC/21	2903370	10
Coupling relay modules with multi-layer gold contact relay, with Push-in connection	① 12 V DC	RIF-0-RPT-12DC/21AU	2903369	10
	② 24 V DC	RIF-0-RPT-24DC/21AU	2903368	10
Coupling relay modules with power contact relay and Push-in connection, negative switching	② 24 V DC	RIF-0-RPT-M-24DC/21	2908327	10



1-N/O relay module with Push-in connection

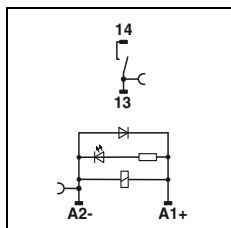

DC coils

Technical data

① ②
see diagram
16 9
5 5
8 8
Yellow LED, Damping diode

1 N/O contact	1 N/O contact
AgSnO	AgSnO, hard gold-plated
250 V AC/DC	30 V AC / 36 V DC
5 V (at 100 mA)	100 mV (at 10 mA)
6 A	50 mA
10 mA (at 12 V)	1 mA (at 12 V)

4 kV_{rms} (50 Hz, 1 min.)
-40 °C ... 60 °C
100% operating factor
Approx. 2x 10⁷ cycles
DIN EN 50178
2 / III

any / In rows with zero spacing
0.14 ... 1.5 mm² / 0.14 ... 1.5 mm² / 26 - 16
6.2 mm / 93 mm / 66 mm
Class A product, see page 605

Ordering data

Type	Order No.	Pcs./ Pkt.
RIF-0-RPT-12DC/ 1	2903362	10
RIF-0-RPT-24DC/ 1	2903361	10
RIF-0-RPT-12DC/ 1AU	2903360	10
RIF-0-RPT-24DC/ 1AU	2903359	10

RIF-0-RPT.../21... (1-PDT)

Operating voltage range

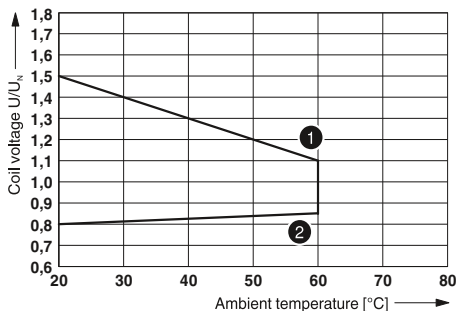

① Maximum continuous voltage at limiting continuous current = 6 A
② Minimum operate voltage
For pre-excitation with U_n and limiting continuous current = 6 A

Service life reduction factor

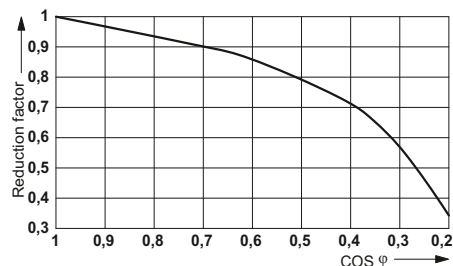

Interrupting rating

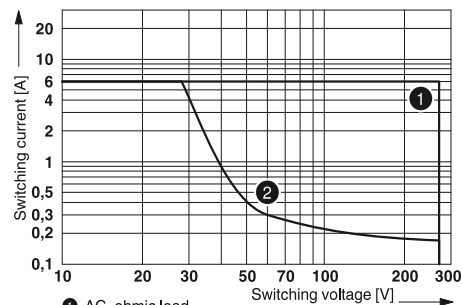

① AC, ohmic load
② DC, ohmic load

Electrical service life

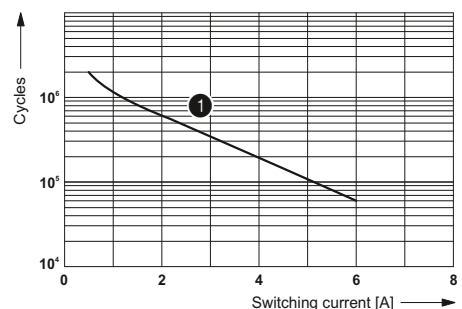

① 250 V AC, ohmic load

RIF-0-RPT.../1... (1-N/O)

Operating voltage range

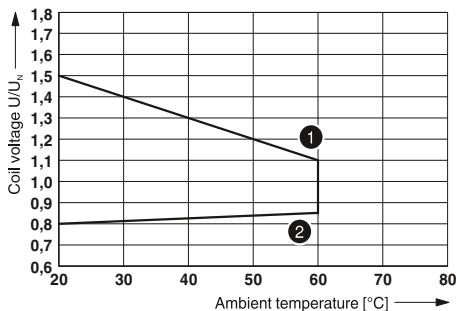

① Maximum continuous voltage at limiting continuous current = 6 A
② Minimum operate voltage
For pre-excitation with U_n and limiting continuous current = 6 A

Service life reduction factor

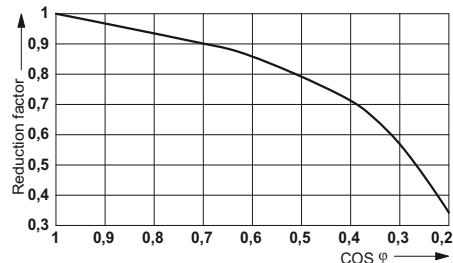

Interrupting rating

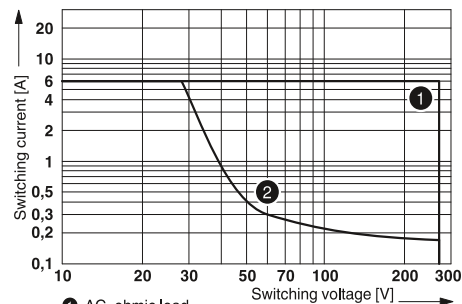

① AC, ohmic load
② DC, ohmic load

Electrical service life

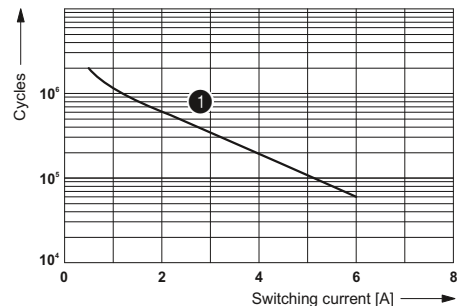

① 250 V AC, ohmic load

Relay modules

Industrial relay system - RIFLINE complete

Fully mounted RIF-0 relay modules

Fully mounted RIF-0 relay modules, consisting of:

- Relay base with screw connection
- 1-PDT or 1-N/O relay
- Relay ejector lever on the housing

The advantages:

- Status LED integrated in the relay base
- Operational reliability thanks to sealed relay
- Safe isolation between coil and contact side
- Professional bridging of adjacent modules saves wiring time
- For FBS 2-6 plug-in bridges for the input and output side, see page 366.

Notes:

General conditions:

Direct alignment in the block, all devices 100% operating time, horizontal or vertical mounting.



new

1-PDT relay module with screw connection

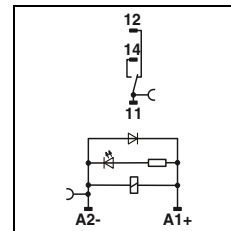

DC coils

Input data	
Permissible range (with reference to U_N)	
Typical input current at U_N	[mA]
Typical response time at U_N	[ms]
Typical release time at U_N	[ms]
Input protection:	
Output data	
Contact type	
Contact material	
Max. switching voltage	
Minimum switching voltage	
Limiting continuous current	
Minimum switching current	
General data	
Test voltage (winding / contact)	
Ambient temperature (operation)	
Nominal operating mode	
Mechanical service life	
Standards/regulations	
Degree of pollution/surge voltage category	
Mounting position/mounting	
Connection data solid/stranded/AWG	
Maximum tightening torque	
Dimensions	W / H / D

Technical data		
①	②	
see diagram		
16	9	
5	5	
8	8	
Yellow LED, Damping diode		
1 PDT	1 PDT	
AgSnO	AgSnO, hard gold-plated	
250 V AC/DC	30 V AC / 36 V DC	
5 V (at 100 mA)	100 mV (at 10 mA)	
6 A	50 mA	
10 mA (at 12 V)	1 mA (at 12 V)	
4 kV _{rms} (50 Hz, 1 min.)		
-40 °C ... 60 °C		
100% operating factor		
Approx. 2x 10 ⁷ cycles		
DIN EN 50178		
2 / III		
any / In rows with zero spacing		
0.5 ... 4 mm ² / 0.5 ... 2.5 mm ² / 20 - 12		
0.5 Nm		
6.2 mm / 84 mm / 82 mm		

Description	Input voltage U_N
Coupling relay modules with power contact relay and screw connection	① 12 V DC
	② 24 V DC
Coupling relay modules with multi-layer gold contact relay, with screw connection	① 12 V DC
	② 24 V DC

Ordering data		
Type	Order No.	Pcs./ Pkt.
RIF-0-RSC-12DC/21	2903375	10
RIF-0-RSC-24DC/21	2903374	10
RIF-0-RSC-12DC/21AU	2903373	10
RIF-0-RSC-24DC/21AU	2903372	10

new



1-N/O relay module with screw connection

RIF-0-RSC.../21... (1-PDT)

Operating voltage range

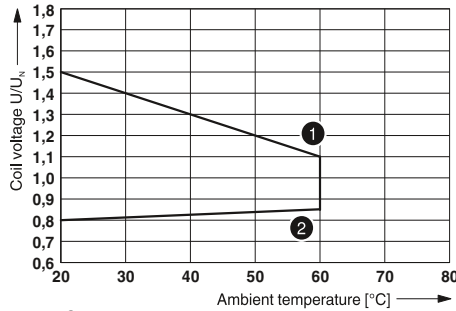

- ① Maximum continuous voltage at limiting continuous current = 6 A
 - ② Minimum operate voltage
- For pre-excitation with U_n and limiting continuous current = 6 A

Interrupting rating

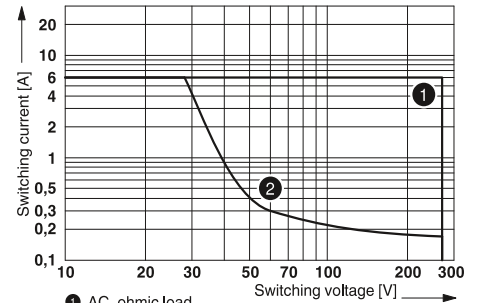

- ① AC, ohmic load
- ② DC, ohmic load

Service life reduction factor with various cos phi

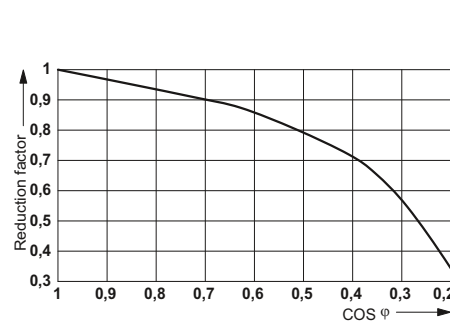

Electrical service life

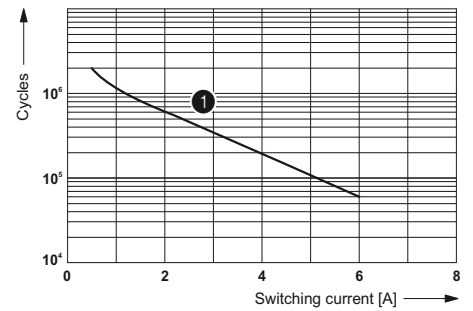

- ① 250 V AC, ohmic load

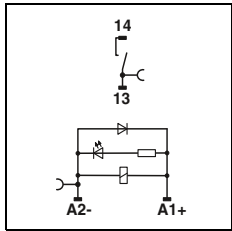

DC coils

Technical data

① ②
see diagram
16 9
5 5
8 8
Yellow LED, Damping diode

1 N/O contact	1 N/O contact
AgSnO	AgSnO, hard gold-plated
250 V AC/DC	30 V AC / 36 V DC
5 V (at 100 mA)	100 mV (at 10 mA)
6 A	50 mA
10 mA (at 12 V)	1 mA (at 12 V)

4 kV_{rms} (50 Hz, 1 min.)
-40 °C ... 60 °C
100% operating factor
Approx. 2x 10⁷ cycles
DIN EN 50178
2 / III

any / In rows with zero spacing
0.5 ... 4 mm² / 0.5 ... 2.5 mm² / 20 - 12
0.5 Nm
6.2 mm / 84 mm / 68 mm

Ordering data

Type	Order No.	Pcs./ Pkt.
RIF-0-RSC-12DC/ 1	2903367	10
RIF-0-RSC-24DC/ 1	2903366	10
RIF-0-RSC-12DC/ 1AU	2903365	10
RIF-0-RSC-24DC/ 1AU	2903364	10

RIF-0-RSC.../1... (1-N/O)

Operating voltage range

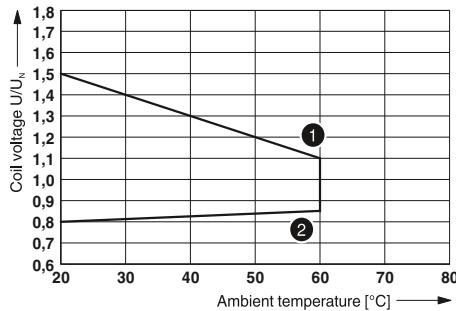

- ① Maximum continuous voltage at limiting continuous current = 6 A
 - ② Minimum operate voltage
- For pre-excitation with U_n and limiting continuous current = 6 A

Interrupting rating

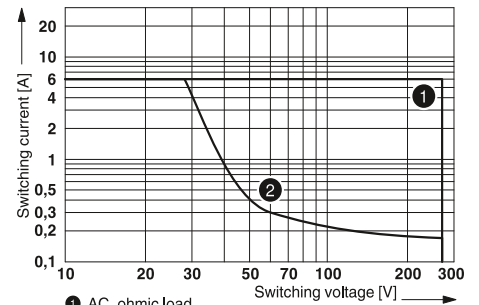

- ① AC, ohmic load
- ② DC, ohmic load

Service life reduction factor

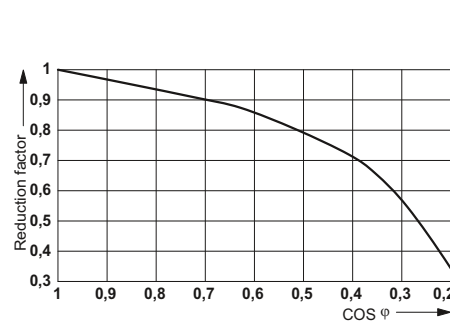

Electrical service life

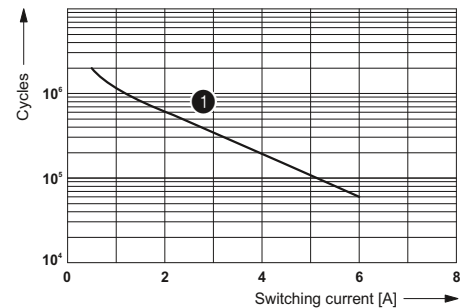

- ① 250 V AC, ohmic load

Relay modules

Industrial relay system - RIFLINE complete

Fully mounted RIF-0 relay modules

Fully mounted RIF-0 relay modules, consisting of:

- Relay base with Push-in connection
- Solid-state relays
- Relay ejector lever on the housing

The advantages:

- Status LED integrated into the base
- RTIII sealed solid-state relay
- Zero voltage switch at AC output
- Professional bridging of adjacent modules saves wiring time



Solid-state relay module with Push-in connection, DC output max. 3 A

ERC

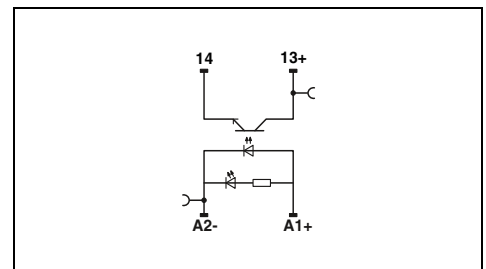

Technical data

Input data	
Rated actuating voltage range with reference to U_C	
Rated actuating current I_C	[mA] 8.5
Switching level (with reference to U_C)	1 signal ("H") > 0.8 0 signal ("L") < 0.4
Typical switch-on time at U_N	[ms] 0.02
Typical switch-off time at U_N	[ms] 0.3
Transmission frequency f_{limit}	[Hz] 300
Input circuit DC	Yellow LED, Freewheeling diode
Output data	
Max. switching voltage	33 V DC
Minimum switching voltage	3 V DC
Maximum switch-on current	15 A (10 ms)
Minimum/maximum switching current	- / 3 A (see derating curve)
Output protection	Reverse polarity protection, surge protection
Voltage drop at maximum limiting continuous current	< 200 mV
Leakage current in off state	-
Phase angle (cos ϕ)	-
Max. load value	-
General data	
Test voltage input/output	2.5 kV _{ms} (50 Hz, 1 min.)
Ambient temperature (operation)	-25 °C ... 60 °C
Standards/regulations	DIN EN 50178
Degree of pollution/surge voltage category	2 / III
Connection data solid/stranded/AWG	0.14 - 1.5 mm ² / 0.14 - 1.5 mm ² / 26 - 16
Dimensions	6.2 mm / 93 mm / 66 mm
EMC note	Class A product, see page 605

Ordering data		
Type	Order No.	Pcs./ Pkt.
RIF-0-OPT-24DC/24DC/2	2905293	10

Description	Rated actuating voltage U_C
Coupling relay modules with solid-state relay and Push-in connection	24 V DC

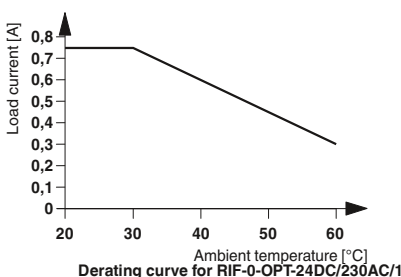
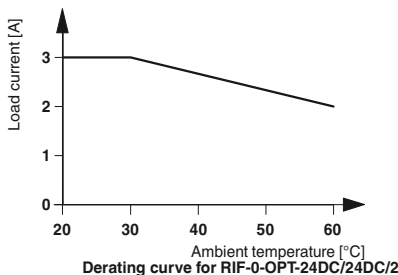

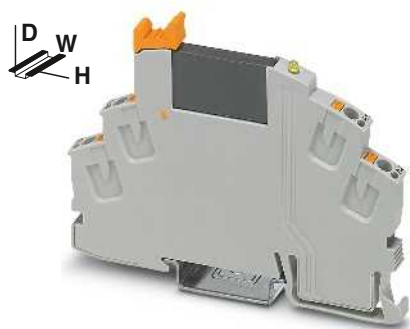

Solid-state relay module with Push-in connection, DC output max. 100 mA

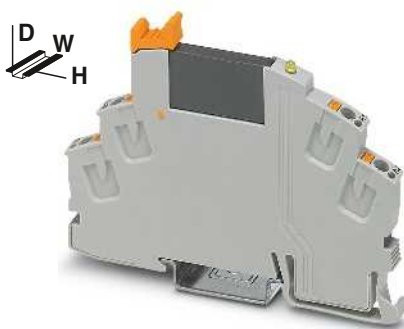

Solid-state relay module with Push-in connection, AC output max. 750 mA

ERIC

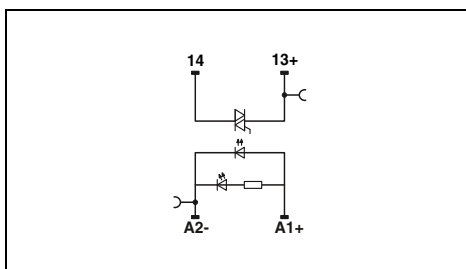
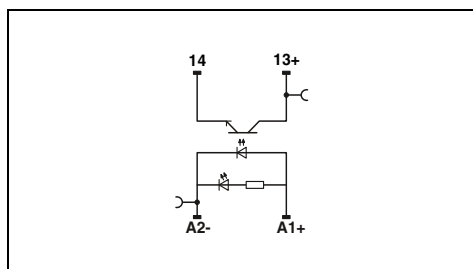

Technical data

Technical data

①
0.8 - 1.2
8.5
> 0.8
< 0.4
0.02
0.3
300
Yellow LED, Freewheeling diode
48 V DC
3 V DC
-
- / 100 mA
Reverse polarity protection, surge protection
< 1 V
-
-
-
2.5 kV _{rms} (50 Hz, 1 min.)
-25 °C ... 60 °C
DIN EN 50178
2 / III
0.14 - 1.5 mm ² / 0.14 - 1.5 mm ² / 26 - 16
6.2 mm / 93 mm / 66 mm
Class A product, see page 605

①
0.8 - 1.2
8
> 0.8
< 0.4
10
10
10
Yellow LED, Freewheeling diode
253 V AC
24 V AC
30 A (10 ms)
10 mA / 0.75 A (see derating curve)
RCV circuit
< 1 V
1 mA (in off state)
0.5
4.5 A ² s (tp = 10 ms, at 25 °C)
2.5 kV _{rms} (50 Hz, 1 min.)
-25 °C ... 60 °C
DIN EN 50178
2 / III
0.14 - 1.5 mm ² / 0.14 - 1.5 mm ² / 26 - 16
6.2 mm / 93 mm / 66 mm
Class A product, see page 605

Ordering data

Ordering data

Type	Order No.	Pcs./ Pkt.
RIF-0-OPT-24DC/48DC/100	2905294	10

Type	Order No.	Pcs./ Pkt.
RIF-0-OPT-24DC/230AC/1	2905295	10

Relay modules

Industrial relay system - RIFLINE complete

Fully mounted RIF-0 relay modules

Fully mounted RIF-0 relay modules, consisting of:

- Relay base with screw connection
- Solid-state relays
- Relay ejector lever on the housing

The advantages:

- Status LED integrated into the base
- RTIII sealed solid-state relay
- Zero voltage switch at AC output
- Professional bridging of adjacent modules saves wiring time

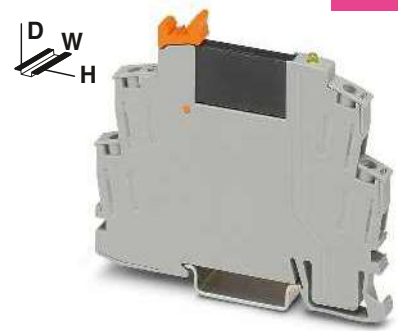

Solid-state relay module with screw connection, DC output max. 3 A

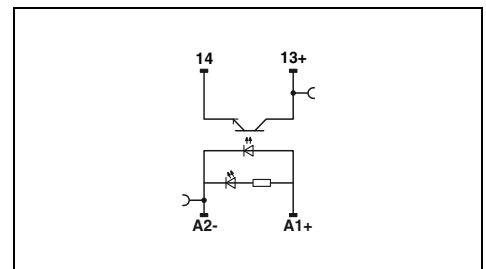

Technical data

Input data	
Rated actuating voltage range with reference to U_C	
Rated actuating current I_C	[mA] 8.5
Switching level (with reference to U_C)	1 signal ("H") > 0.8 0 signal ("L") < 0.4
Typical switch-on time at U_N	[ms] 0.02
Typical switch-off time at U_N	[ms] 0.3
Transmission frequency f_{limit}	[Hz] 300
Input circuit DC	Yellow LED, Freewheeling diode
Output data	
Max. switching voltage	33 V DC
Minimum switching voltage	3 V DC
Maximum switch-on current	15 A (10 ms)
Minimum/maximum switching current	- / 3 A (see derating curve)
Output protection	Reverse polarity protection, surge protection
Voltage drop at maximum limiting continuous current	< 200 mV
Leakage current in off state	-
Phase angle (cos ϕ)	-
Max. load value	-
General data	
Test voltage input/output	2.5 kV _{ms} (50 Hz, 1 min.)
Ambient temperature (operation)	-25 °C ... 60 °C
Standards/regulations	DIN EN 50178
Degree of pollution/surge voltage category	2 / III
Connection data solid/stranded/AWG	0.5 - 4 mm ² / 0.5 - 2.5 mm ² / 20 - 12
Maximum tightening torque	0.5 Nm
Dimensions	6.2 mm / 84 mm / 68 mm

①	0.8 - 1.2
	8.5
	> 0.8
	< 0.4
	0.02
	0.3
	300
	Yellow LED, Freewheeling diode
	33 V DC
	3 V DC
	15 A (10 ms)
	- / 3 A (see derating curve)
	Reverse polarity protection, surge protection
	< 200 mV
	-
	-
	-
	2.5 kV _{ms} (50 Hz, 1 min.)
	-25 °C ... 60 °C
	DIN EN 50178
	2 / III
	0.5 - 4 mm ² / 0.5 - 2.5 mm ² / 20 - 12
	0.5 Nm
	6.2 mm / 84 mm / 68 mm

Ordering data

Description	Rated actuating voltage U_C
Coupling relay modules with solid-state relay and screw connection	24 V DC

Type	Order No.	Pcs./ Pkt.
RIF-0-OSC-24DC/24DC/2	2905657	10

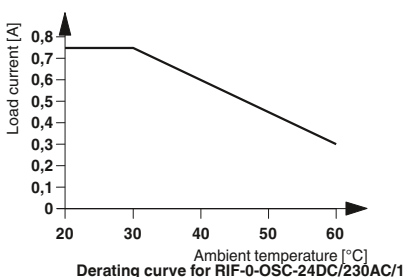
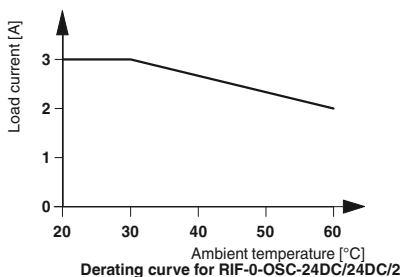

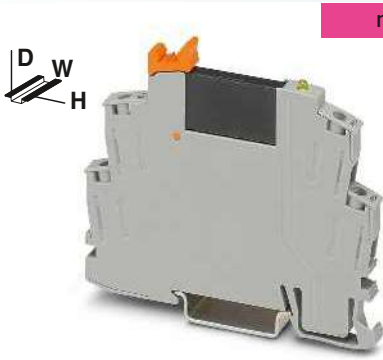

new

Solid-state relay module with screw connection, DC output max. 100 mA

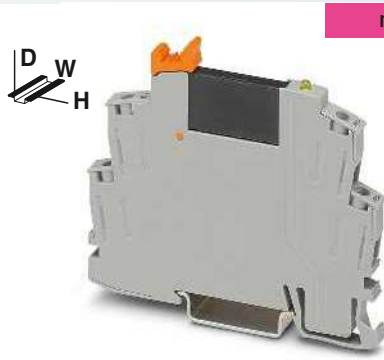

new

Solid-state relay module with screw connection, AC output max. 750 mA

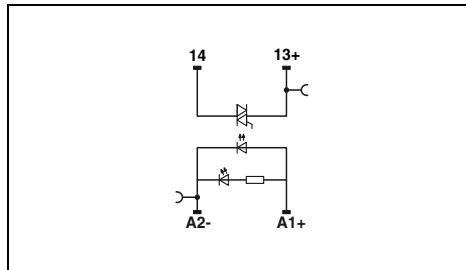
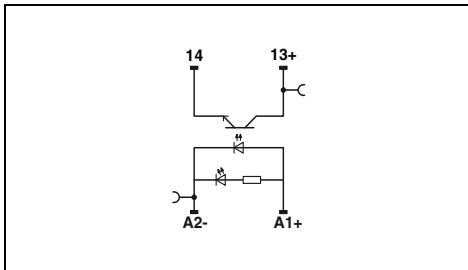

Technical data

Technical data

①
0.8 -
1.2
8.5
> 0.8
< 0.4
0.02
0.3
300
Yellow LED , Freewheeling diode

48 V DC
3 V DC
-
- / 100 mA
Reverse polarity protection, surge protection
< 1 V

-
-
-

2.5 kV_{rms} (50 Hz, 1 min.)
-25 °C ... 60 °C
DIN EN 50178
2 / III

0.5 - 4 mm² / 0.5 - 2.5 mm² / 20 - 12
0.5 Nm
6.2 mm / 84 mm / 68 mm

①
0.8 -
1.2
8
> 0.8
< 0.4
10
10
10
Yellow LED , Freewheeling diode

253 V AC
24 V AC
30 A (10 ms)
10 mA / 0.75 A (see derating curve)
RCV circuit
< 1 V

1 mA (in off state)
0.5
4.5 A²s (tp = 10 ms, at 25 °C)

2.5 kV_{rms} (50 Hz, 1 min.)
-25 °C ... 60 °C
DIN EN 50178
2 / III

0.5 - 4 mm² / 0.5 - 2.5 mm² / 20 - 12
0.5 Nm
6.2 mm / 84 mm / 68 mm

Ordering data

Ordering data

Type	Order No.	Pcs./ Pkt.
RIF-0-OSC-24DC/48DC/100	2905658	10

Type	Order No.	Pcs./ Pkt.
RIF-0-OSC-24DC/230AC/1	2905656	10

Relay modules

Industrial relay system - RIFLINE complete

Fully mounted RIF-1 relay modules

Fully mounted RIF-1 relay modules, consisting of:

- Relay base with Push-in connection
- 1 or 2-PDT relays
- Relay retaining bracket
- Interference suppression module

The advantages:

- Logical contact arrangement thanks to 1/3-level relay base
- Operational reliability thanks to sealed relay
- Safe isolation between coil and contact side
- Professional bridging of adjacent modules saves wiring time
- For FBS 2-6 plug-in bridges for the input side (A2), see page 366.
- For FBS 2-8 plug-in bridges for the output side (11/21), see page 366.

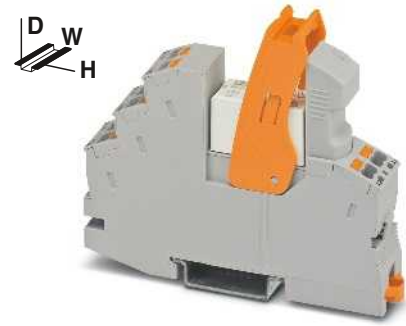

1-PDT relay module with Push-in connection

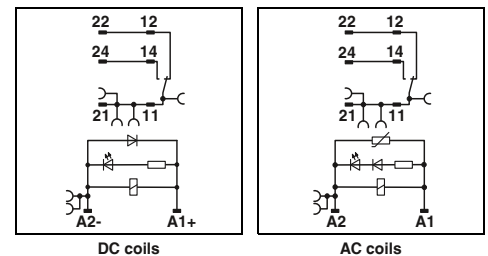

Technical data

	①	②	③	④	⑤	
Input data	see diagram					
Permissible range (with reference to U_N)						
Typical input current at U_N	[mA]	33	18	33	8	6
Typical response time at U_N	[ms]	8	8	3 - 12	3 - 12	3 - 12
Typical release time at U_N	[ms]	10	10	3 - 20	3 - 20	3 - 20
Input circuit AC	Yellow LED, Varistor					
Input circuit DC	Yellow LED, Damping diode					
Output data						
Contact type	1 PDT		1 PDT			
Contact material	AgNi		AgNi, hard gold-plated			
Max. switching voltage	250 V AC/DC		30 V AC / 36 V DC			
Minimum switching voltage	12 V (at 10 mA)		100 mV (at 10 mA)			
Limiting continuous current	11 A (see diagram)		50 mA			
Maximum switch-on current AC	25 A (20 ms, N/O contact)		50 mA			
Maximum switch-on current DC	50 A (20 ms, N/O contact)		50 mA			
Minimum switching current	10 mA (at 12 V)		1 mA (at 24 V)			
General data						
Test voltage (winding / contact)	4 kV _{rms} (50 Hz, 1 min.)					
Ambient temperature (operation), AC	-40 °C ... 50 °C					
Ambient temperature (operation), DC	-40 °C ... 70 °C					
Nominal operating mode	100% operating factor					
Mechanical service life, AC	Approx. 10 ⁷ cycles					
Mechanical service life, DC	approx. 3x 10 ⁷ cycles					
Standards/regulations	DIN EN 50178					
Degree of pollution/surge voltage category	2 / III					
Mounting position/mounting	any / In rows with zero spacing					
Connection data solid/stranded/AWG	0.14 ... 1.5 mm ² / 0.14 ... 1.5 mm ² / 26 - 16					
Dimensions	16 mm / 93 mm / 75 mm					
EMC note	Class A product, see page 605					

Ordering data

Description	Input voltage U_N	Type	Order No.	Pcs./ Pkt.
Coupling relay modules with power contact relay and Push-in connection	① 12 V DC	RIF-1-RPT-LDP-12DC/1X21	2906224	10
	② 24 V DC	RIF-1-RPT-LDP-24DC/1X21	2903342	10
	③ 24 V AC	RIF-1-RPT-LV-24AC/1X21	2903341	10
	④ 120 V AC	RIF-1-RPT-LV-120AC/1X21	2903340	10
	⑤ 230 V AC	RIF-1-RPT-LV-230AC/1X21	2903339	10
Coupling relay modules with multi-layer gold contact relay, with Push-in connection	① 24 V DC	RIF-1-RPT-LDP-24DC/1X21AU	2903338	10
	② 24 V AC	RIF-1-RPT-LV-24AC/1X21AU	2903337	10
	③ 120 V AC	RIF-1-RPT-LV-120AC/1X21AU	2903336	10
	④ 230 V AC	RIF-1-RPT-LV-230AC/1X21AU	2903335	10

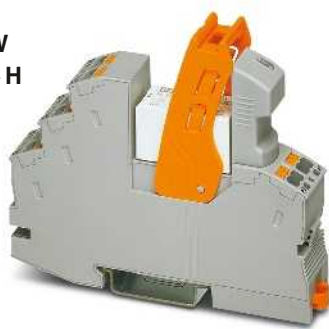

2-PDT relay module with Push-in connection

RIF-1-RPT.../1X21... (1-PDT)

Operating voltage range

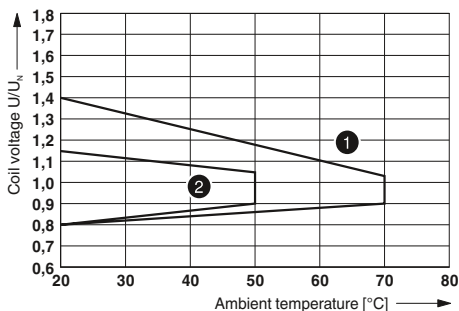

- 1 DC coils
- 2 AC coils

Interrupting rating

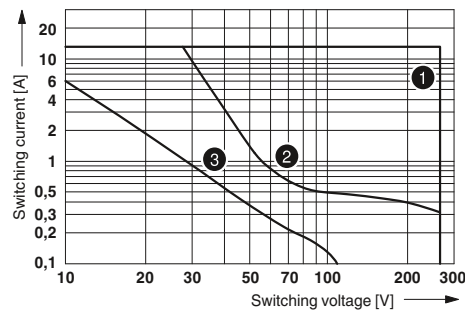

- 1 AC, ohmic load
- 2 DC, ohmic load
- 3 DC, L/R = 40 ms

Contact derating

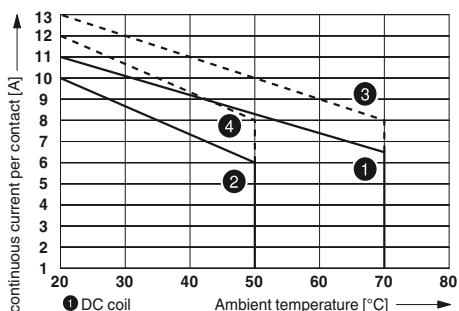

- 1 DC coil
- 2 AC coil
- 3 DC coil, jumper between 11 and 21
- 4 AC coil, jumper between 11 and 21

Electrical service life

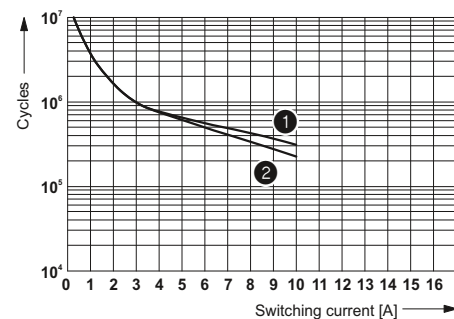

- 1 250 V AC, ohmic load (DC coils)
- 2 250 V AC, ohmic load (AC coils)

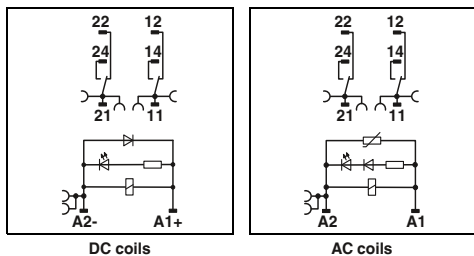

Technical data

①	②	③	④	⑤
see diagram				
33	18	33	8	6
8	8	3-12	3-12	3-12
10	10	3-20	3-20	3-20
Yellow LED, Varistor				
Yellow LED, Damping diode				

2 PDT	2 PDT
AgNi	AgNi, hard gold-plated
250 V AC/DC	30 V AC / 36 V DC
5 V (at 10 mA)	100 mV (at 10 mA)
8 A (see diagram)	50 mA
12 A (20 ms, N/O contact)	50 mA
25 A (20 ms, N/O contact)	50 mA
10 mA (At 5 V)	1 mA (at 24 V)

4 kV_{rms} (50 Hz, 1 min.)
 -40 °C ... 50 °C
 -40 °C ... 70 °C
 100% operating factor
 Approx. 10^7 cycles
 approx. 3×10^7 cycles
 DIN EN 50178
 2 / III

any / In rows with zero spacing
 0.14 ... 1.5 mm² / 0.14 ... 1.5 mm² / 26 - 16
 16 mm / 93 mm / 75 mm
 Class A product, see page 605

Ordering data

Type	Order No.	Pcs./Pkt.
RIF-1-RPT-LDP-12DC/2X21	2906223	10
RIF-1-RPT-LDP-24DC/2X21	2903334	10
RIF-1-RPT-LV-24AC/2X21	2903333	10
RIF-1-RPT-LV-120AC/2X21	2903332	10
RIF-1-RPT-LV-230AC/2X21	2903331	10
RIF-1-RPT-LDP-24DC/2X21AU	2903330	10
RIF-1-RPT-LV-24AC/2X21AU	2903329	10
RIF-1-RPT-LV-120AC/2X21AU	2903328	10
RIF-1-RPT-LV-230AC/2X21AU	2903327	10

RIF-1-RPT.../2X21... (2-PDT)

Operating voltage range

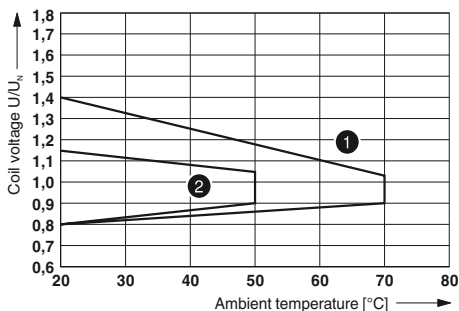

- 1 DC coils
- 2 AC coils

Interrupting rating

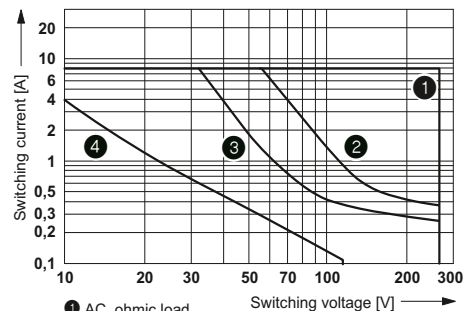

- 1 AC, ohmic load
- 2 DC, ohmic load, contacts in series
- 3 DC, ohmic load
- 4 DC, L/R = 40 ms

Contact derating

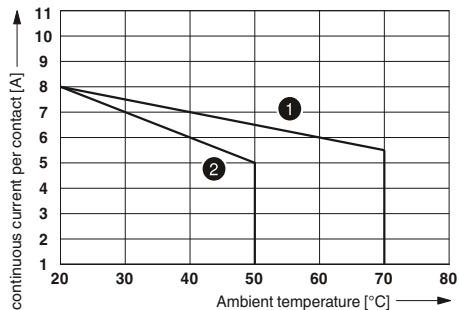

- 1 DC coil
- 2 AC coil

Electrical service life

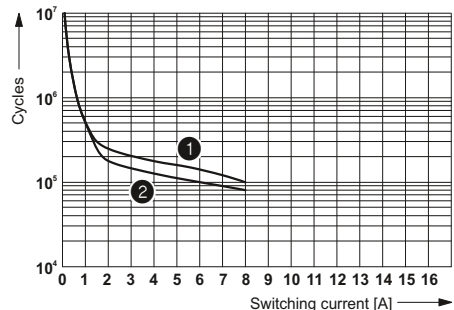

- 1 250 V AC, ohmic load (DC coils)
- 2 250 V AC, ohmic load (AC coils)

Relay modules

Industrial relay system - RIFLINE complete

Fully mounted RIF-1 relay modules

Fully mounted RIF-1 relay modules, consisting of:

- Relay base with screw connection
- 1 or 2-PDT relays
- Relay retaining bracket
- Interference suppression module

The advantages:

- Logical contact arrangement thanks to 1/3-level relay base
- Operational reliability thanks to sealed relay
- Safe isolation between coil and contact side
- Professional bridging of adjacent modules saves wiring time
- For FBS 2-6 plug-in bridges for the input side (A2), see page 366.
- For FBS 2-8 plug-in bridges for the output side (11/21), see page 366.



new

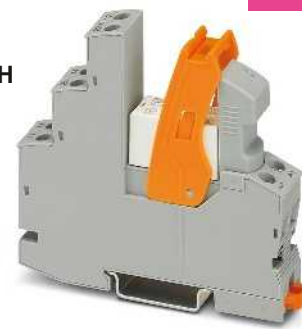

1-PDT relay module with screw connection

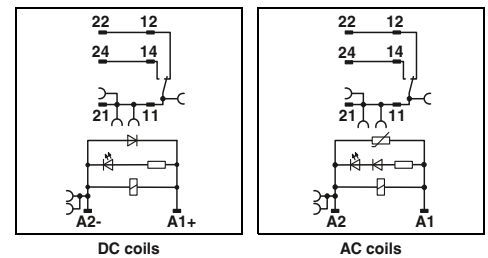

Input data	
Permissible range (with reference to U_N)	
Typical input current at U_N	[mA]
Typical response time at U_N	[ms]
Typical release time at U_N	[ms]
Input circuit AC	
Input circuit DC	
Output data	
Contact type	
Contact material	
Max. switching voltage	
Minimum switching voltage	
Limiting continuous current	
Maximum switch-on current AC	
Maximum switch-on current DC	
Minimum switching current	
General data	
Test voltage (winding / contact)	
Ambient temperature (operation), AC	
Ambient temperature (operation), DC	
Nominal operating mode	
Mechanical service life, AC	
Mechanical service life, DC	
Standards/regulations	
Degree of pollution/surge voltage category	
Mounting position/mounting	
Connection data solid/stranded/AWG	
Dimensions	W / H / D
EMC note	

Technical data				
①	②	③	④	⑤
see diagram				
33	18	33	8	6
8	8	3 - 12	3 - 12	3 - 12
10	10	3 - 20	3 - 20	3 - 20
Yellow LED, Varistor				
Yellow LED, Damping diode				
1 PDT		1 PDT		
AgNi		AgNi, hard gold-plated		
250 V AC/DC		30 V AC / 36 V DC		
12 V (at 10 mA)		100 mV (at 10 mA)		
11 A (see diagram)		50 mA		
25 A (20 ms, N/O contact)		25 A (20 ms, N/O contact)		
50 A (20 ms, N/O contact)		50 mA		
10 mA (at 12 V)		1 mA (at 24 V)		
4 kV _{rms} (50 Hz, 1 min.)				
-40 °C ... 50 °C				
-40 °C ... 70 °C				
100% operating factor				
Approx. 10 ⁷ cycles				
approx. 3x 10 ⁷ cycles				
DIN EN 50178				
2 / III				
any / In rows with zero spacing				
0.14 ... 6 mm ² / 0.14 ... 4 mm ² / 26 - 10				
16 mm / 89 mm / 75 mm				
Class A product, see page 605				

Description	Input voltage U_N
Coupling relay modules with power contact relay and screw connection	
①	12 V DC
②	24 V DC
③	24 V AC
④	120 V AC
⑤	230 V AC
Coupling relay modules with multi-layer gold contact relay, with screw connection	
①	24 V DC
②	24 V AC
③	120 V AC
④	230 V AC

Ordering data		
Type	Order No.	Pcs./ Pkt.
RIF-1-RSC-LDP-12DC/1X21	2908500	10
RIF-1-RSC-LDP-24DC/1X21	2903358	10
RIF-1-RSC-LV-24AC/1X21	2903357	10
RIF-1-RSC-LV-120AC/1X21	2903356	10
RIF-1-RSC-LV-230AC/1X21	2903355	10
RIF-1-RSC-LDP-24DC/1X21AU	2903354	10
RIF-1-RSC-LV-24AC/1X21AU	2903353	10
RIF-1-RSC-LV-120AC/1X21AU	2903352	10
RIF-1-RSC-LV-230AC/1X21AU	2903351	10

new



2-PDT relay module with screw connection

RIF-1-RPT.../1X21... (1-PDT)

Operating voltage range

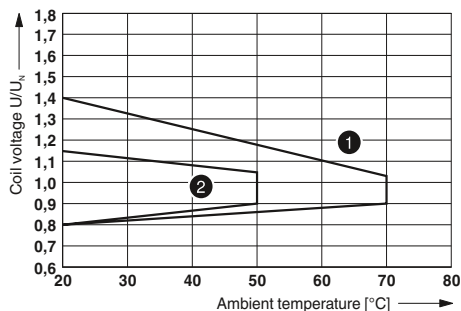

Interrupting rating

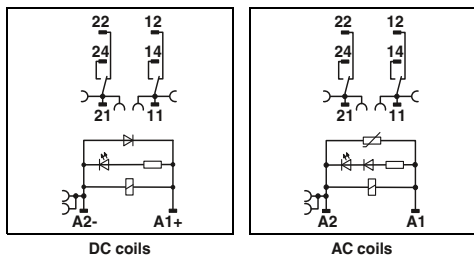
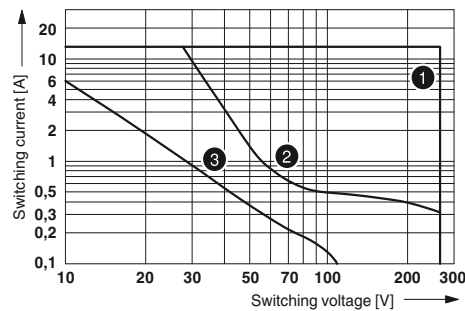

Contact derating

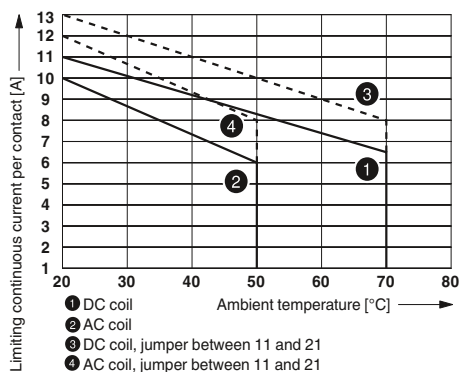

Electrical service life

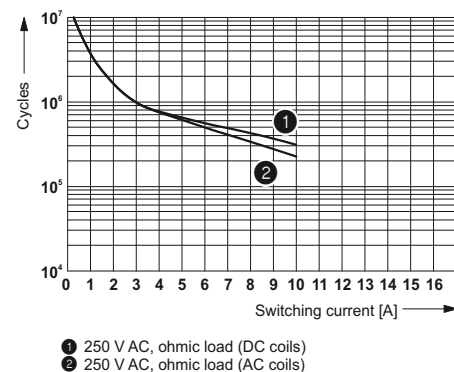

Technical data

①	②	③	④	⑤
see diagram				
33	18	33	8	6
8	8	3-12	3-12	3-12
10	10	3-20	3-20	3-20
Yellow LED, Varistor				
Yellow LED, Damping diode				

2 PDT	2 PDT
AgNi	AgNi, hard gold-plated
250 V AC/DC	30 V AC / 36 V DC
5 V (at 10 mA)	100 mV (at 10 mA)
8 A (see diagram)	50 mA
12 A (20 ms, N/O contact)	50 mA
25 A (20 ms, N/O contact)	50 mA
10 mA (At 5 V)	1 mA (at 24 V)

4 kV_{rms} (50 Hz, 1 min.)
 -40 °C ... 50 °C
 -40 °C ... 70 °C
 100% operating factor
 Approx. 10⁷ cycles
 approx. 3x 10⁷ cycles
 DIN EN 50178
 2 / III

any / In rows with zero spacing
 0.14 ... 6 mm² / 0.14 ... 4 mm² / 26 - 10
 16 mm / 89 mm / 75 mm
 Class A product, see page 605

Ordering data

Type	Order No.	Pcs./ Pkt.
RIF-1-RSC-LDP-12DC/2X21	2908501	10
RIF-1-RSC-LDP-24DC/2X21	2903350	10
RIF-1-RSC-LV-24AC/2X21	2903349	10
RIF-1-RSC-LV-120AC/2X21	2903348	10
RIF-1-RSC-LV-230AC/2X21	2903347	10
RIF-1-RSC-LDP-24DC/2X21AU	2903346	10
RIF-1-RSC-LV-24AC/2X21AU	2903345	10
RIF-1-RSC-LV-120AC/2X21AU	2903344	10
RIF-1-RSC-LV-230AC/2X21AU	2903343	10

RIF-1-RSC.../2X21... (2-PDT)

Operating voltage range

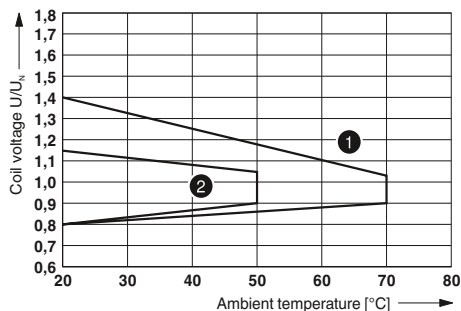

Interrupting rating

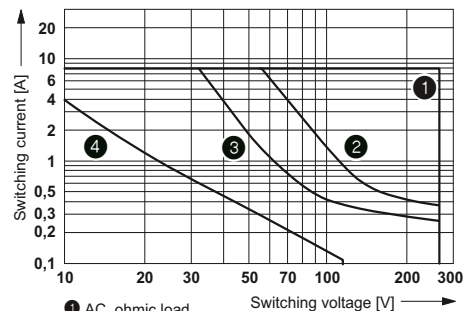

Contact derating

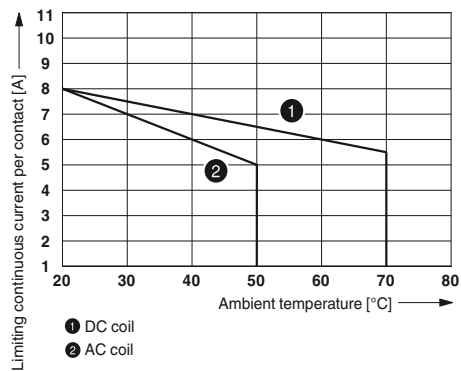

Electrical service life

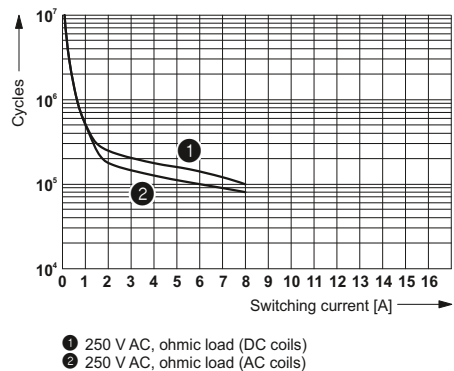

Relay modules

Industrial relay system - RIFLINE complete

Fully mounted RIF-1 relay modules

Fully mounted RIF-1 relay modules, consisting of:

- Relay base with Push-in connection
- 1 or 2-PDT relays with detectable manual operation
- Relay retaining bracket
- Interference suppression module (AC types only)

The advantages:

- Relay with lockable manual operation and status LED
- With DC types, freewheeling diode is integrated into relay
- Mechanical switch position indicator
- Professional bridging of adjacent modules saves wiring time



1-PDT relay module with Push-in connection and manual operation

ERC

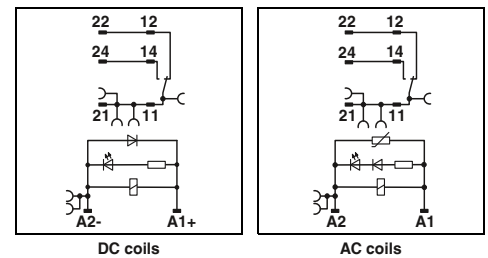

DC coils

AC coils

Technical data

	①	②	③
Input data	see diagram		
Permissible range (with reference to U_N)	18	7	3.5
Typical input current at U_N	[mA]	9	4 - 10
Typical response time at U_N	[ms]	10	3 - 20
Typical release time at U_N	[ms]		3 - 20
Input circuit AC	Yellow LED, Varistor		
Input circuit DC	Yellow LED, Damping diode		
Output data	1 PDT		
Contact type	AgNi		
Contact material	250 V AC/DC		
Max. switching voltage	12 V (at 10 mA)		
Minimum switching voltage	see diagram		
Limiting continuous current	32 A (20 ms, N/O contact)		
Maximum switch-on current AC	24 A (20 ms, N/O contact)		
Maximum switch-on current DC	10 mA (at 12 V)		
Minimum switching current			
General data	4 kV _{rms} (50 Hz, 1 min.)		
Test voltage (winding / contact)	-40 °C ... 50 °C		
Ambient temperature (operation), AC	-40 °C ... 60 °C		
Ambient temperature (operation), DC	100% operating factor		
Nominal operating mode	Approx. 5 x 10 ⁶ cycles		
Mechanical service life	DIN EN 50178		
Standards/regulations	2 / III		
Degree of pollution/surge voltage category	any / In rows with zero spacing		
Mounting position/mounting	0.14 ... 1.5 mm ² / 0.14 ... 1.5 mm ² / 26 - 16		
Connection data solid/stranded/AWG	16 mm / 93 mm / 75 mm		
Dimensions	Class A product, see page 605		
EMC note			

Ordering data

Description	Input voltage U_N	Type	Order No.	Pcs./ Pkt.
Coupling relay modules with power contact relay with manual operation and Push-in connection	① 24 V DC	RIF-1-RPT-LDP-24DC/1X21MS	2905289	10
	② 120 V AC	RIF-1-RPT-LV-120AC/1X21MS	2909776	10
	③ 230 V AC	RIF-1-RPT-LV-230AC/1X21MS	2905290	10



2-PDT relay module with Push-in connection and manual operation

RIF-1-RPT.../1X21... (1-PDT)

Operating voltage range

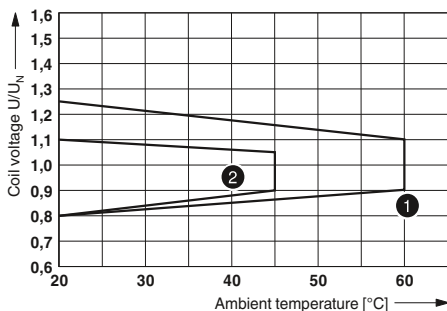

- 1 DC coils
- 2 AC coils

Interrupting rating

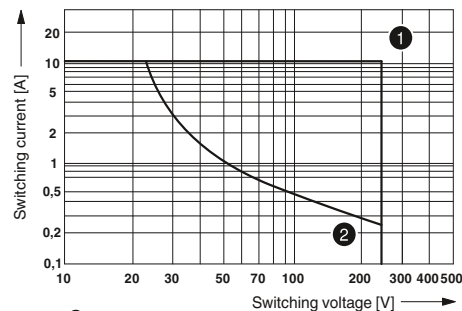

- 1 = AC, ohmic load
- 2 = DC, ohmic load

Contact derating

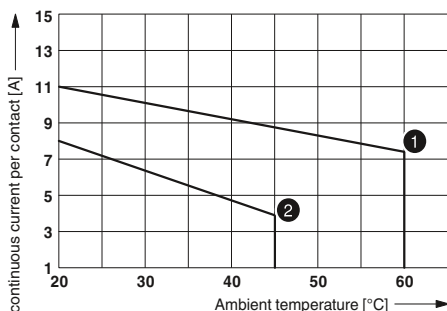

- 1 DC coil
- 2 AC coil

Electrical service life

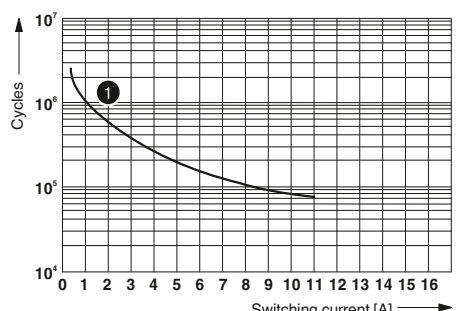

- 1 = 250 V AC, ohmic load

ERIC

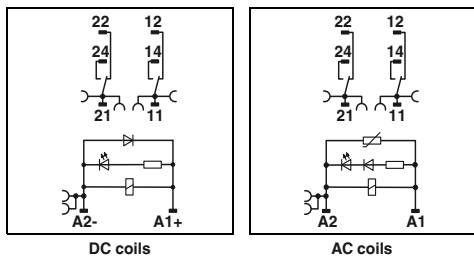

Technical data

- ① see diagram
- ② 18 7 3.5
- ③ 9 4 - 10 4 - 10
- 10 3 - 20 3 - 20
- Yellow LED, Varistor
- Yellow LED, Damping diode

- 2 PDT
- AgNi
- 250 V AC/DC
- 12 V (at 10 mA)
- see diagram
- 16 A (20 ms, N/O contact)
- 12 A (20 ms, N/O contact)
- 10 mA (at 12 V)

- 4 kV_{rms} (50 Hz, 1 min.)
- 40 °C ... 45 °C
- 40 °C ... 60 °C
- 100% operating factor
- Approx. 5 × 10⁶ cycles
- DIN EN 50178
- 2 / III

- any / In rows with zero spacing
- 0.14 ... 1.5 mm² / 0.14 ... 1.5 mm² / 26 - 16
- 16 mm / 93 mm / 75 mm
- Class A product, see page 605

Ordering data

Type	Order No.	Pcs./ Pkt.
RIF-1-RPT-LDP-24DC/2X21MS	2905291	10
RIF-1-RPT-LV-120AC/2X21MS	2909775	10
RIF-1-RPT-LV-230AC/2X21MS	2905292	10

RIF-1-RPT.../2X21... (2-PDT)

Operating voltage range

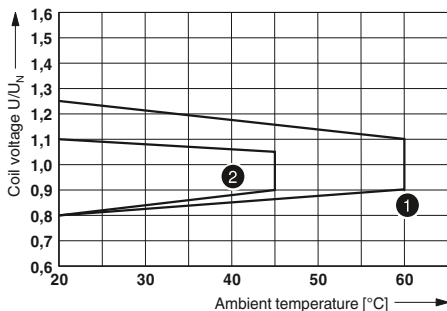

- 1 DC coils
- 2 AC coils

Interrupting rating

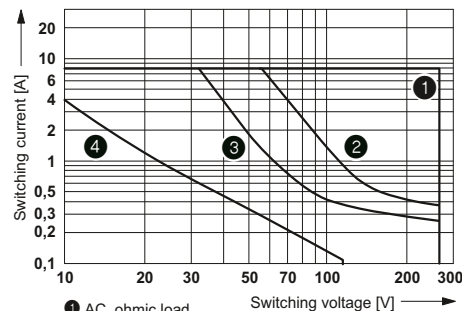

- 1 AC, ohmic load
- 2 DC, ohmic load, contacts in series
- 3 DC, ohmic load
- 4 DC, L/R = 40 ms

Contact derating

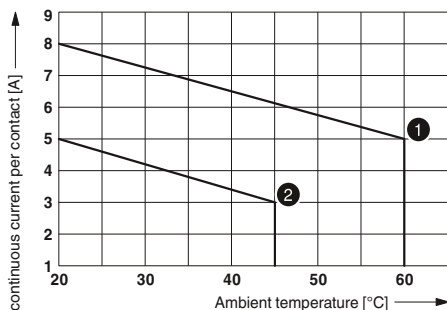

- 1 DC coil
- 2 AC coil

Electrical service life

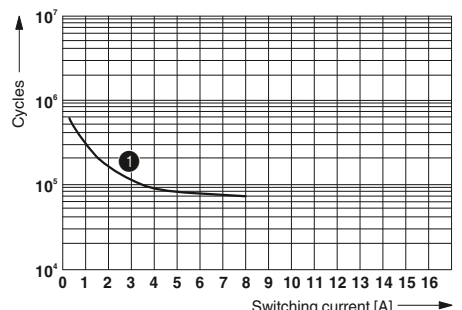

- 1 250 V AC, ohmic load

Relay modules

Industrial relay system - RIFLINE complete

Fully mounted RIF-1 relay modules

Fully mounted RIF-1 relay modules, consisting of:

- Relay base with screw connection
- 1 or 2-PDT relays with detectable manual operation
- Relay retaining bracket
- Interference suppression module (AC types only)

The advantages:

- Relay with lockable manual operation and status LED
- With DC types, freewheeling diode is integrated into relay
- Mechanical switch position indicator
- Professional bridging of adjacent modules saves wiring time



new



1-PDT relay module with screw connection and manual operation

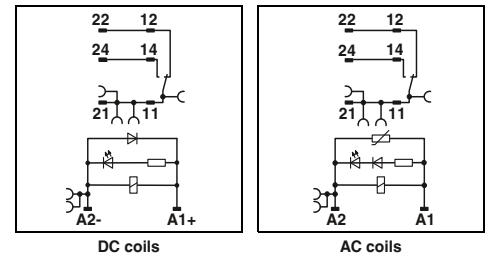

DC coils

AC coils

Technical data

	①	②	③
Input data	see diagram		
Permissible range (with reference to U_N)	18	7	4.5
Typical input current at U_N	[mA]	9	4 - 10
Typical response time at U_N	[ms]	10	3 - 20
Typical release time at U_N	[ms]		4 - 20
Input circuit AC	Yellow LED, Varistor		
Input circuit DC	Yellow LED, Damping diode		
Output data	1 PDT		
Contact type	AgNi		
Contact material	250 V AC/DC		
Max. switching voltage	12 V (at 10 mA)		
Minimum switching voltage	see diagram		
Limiting continuous current	32 A (20 ms, N/O contact)		
Maximum switch-on current AC	24 A (20 ms, N/O contact)		
Maximum switch-on current DC	10 mA (at 12 V)		
Minimum switching current			
General data	4 kV _{rms} (50 Hz, 1 min.)		
Test voltage (winding / contact)	-40 °C ... 50 °C		
Ambient temperature (operation), AC	-40 °C ... 60 °C		
Ambient temperature (operation), DC	100% operating factor		
Nominal operating mode	Approx. 5 x 10 ⁶ cycles		
Mechanical service life	DIN EN 50178		
Standards/regulations	2 / III		
Degree of pollution/surge voltage category			
Mounting position/mounting	any / In rows with zero spacing		
Connection data solid/stranded/AWG	0.14 ... 6 mm ² / 0.14 ... 4 mm ² / 26 - 10		
Dimensions	W / H / D 16 mm / 89 mm / 75 mm		
EMC note	Class A product, see page 605		

Ordering data

Description	Input voltage U_N	Type	Order No.	Pcs./ Pkt.
Coupling relay modules with power contact relay with manual operation and screw connection	① 24 V DC	RIF-1-RSC-LDP-24DC/1X21MS	2905659	10
	② 120 V AC	RIF-1-RSC-LV-120AC/1X21MS	2909774	10
	③ 230 V AC	RIF-1-RSC-LV-230AC/1X21MS	2905661	10

new

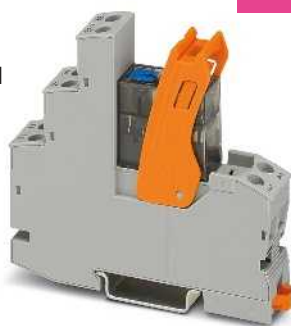

2-PDT relay module with screw connection and manual operation

RIF-1-RPT.../1X21... (1-PDT)

Operating voltage range

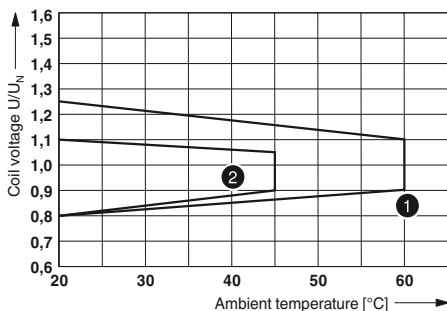

1 DC coils
2 AC coils

Interrupting rating

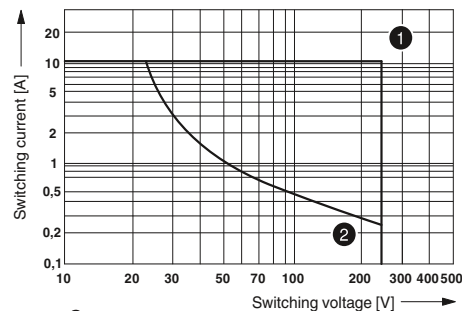

1 = AC, ohmic load
2 = DC, ohmic load

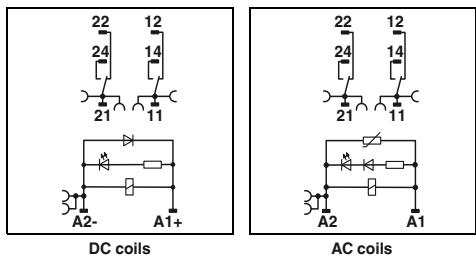

DC coils

AC coils

Contact derating

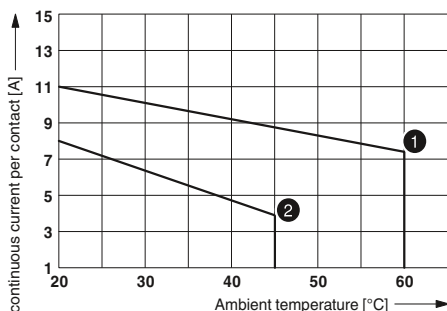

1 DC coil
2 AC coil

Electrical service life

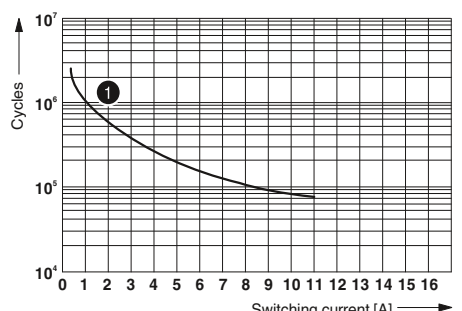

1 = 250 V AC, ohmic load

Technical data

- ① see diagram
- ② 18 7 4.5
- ③ 9 4 - 10 4 - 12
- 10 3 - 20 4 - 20
- Yellow LED, Varistor
- Yellow LED, Damping diode

- 2 PDT
- AgNi
- 250 V AC/DC
- 12 V (at 10 mA)
- see diagram
- 16 A (20 ms, N/O contact)
- 12 A (20 ms, N/O contact)
- 10 mA (at 12 V)

- 4 kV_{rms} (50 Hz, 1 min.)
- 40 °C ... 45 °C
- 40 °C ... 60 °C
- 100% operating factor
- Approx. 5 × 10⁶ cycles
- DIN EN 50178
- 2 / III

- any / In rows with zero spacing
- 0.14 ... 6 mm² / 0.14 ... 4 mm² / 26 - 10
- 16 mm / 89 mm / 75 mm
- Class A product, see page 605

Ordering data

Type	Order No.	Pcs./ Pkt.
RIF-1-RSC-LDP-24DC/2X21MS	2905660	10
RIF-1-RSC-LV-120AC/2X21MS	2909773	10
RIF-1-RSC-LV-230AC/2X21MS	2905662	10

RIF-1-RSC.../2X21... (2-PDT)

Operating voltage range

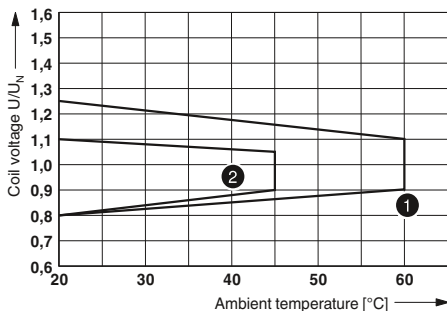

1 DC coils
2 AC coils

Interrupting rating

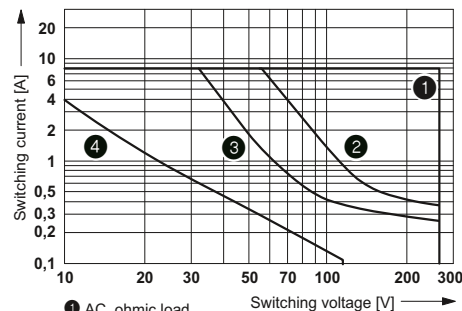

1 AC, ohmic load
2 DC, ohmic load, contacts in series
3 DC, ohmic load
4 DC, L/R = 40 ms

Contact derating

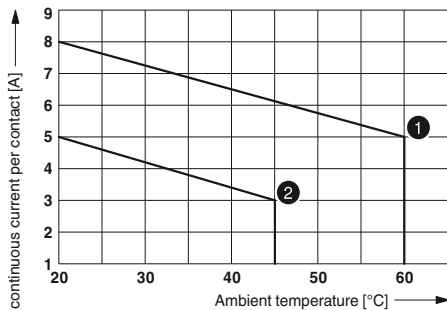

1 DC coil
2 AC coil

Electrical service life

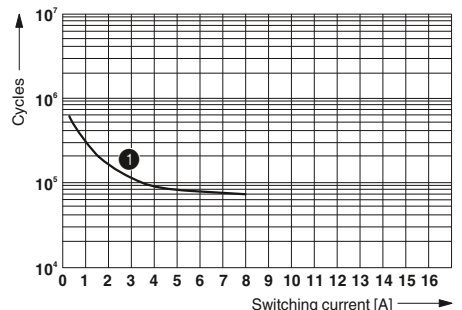

1 250 V AC, ohmic load

Relay modules

Industrial relay system - RIFLINE complete

Fully mounted RIF-1 relay modules

Fully mounted RIF-1 relay modules, consisting of:

- Relay base with Push-in connection
- 1-N/O relay
- Relay retaining bracket

The advantages:

- Maximum inrush current up to 130 A
- Logical contact arrangement thanks to 1/3-level relay base
- Operational reliability thanks to sealed relay
- Safe isolation between coil and contact side
- Professional bridging of adjacent modules saves wiring time
- For FBS 2-6 plug-in bridges for the input side (A2), see page 366.
- For FBS 2-8 plug-in bridges for the output side (11/21), see page 366.



new



1-N/O relay module with Push-in and screw connection

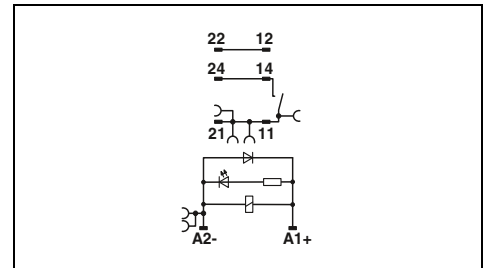

Technical data

Input data	①
Permissible range (with reference to U_N)	see diagram
Typical input current at U_N	18 [mA]
Typical response time at U_N	8 [ms]
Typical release time at U_N	10 [ms]
Input circuit DC	Yellow LED , Polarity protection diode , Damping diode
Output data	
Contact type	1 N/O contact
Contact material	AgSnO
Max. switching voltage	250 V AC/DC
Minimum switching voltage	12 V AC/DC (at 100 mA)
Limiting continuous current	6 A
Maximum switch-on current DC	80 A (for 20 ms) / 130 A (peak, at capacitive load, 230 V AC, 24 μ F)
Minimum switching current	100 mA (at 12 V DC)
General data	
Test voltage (winding / contact)	4 kV AC (50 Hz, 1 min.)
Ambient temperature (operation), DC	-40 °C ... 70 °C
Nominal operating mode	100% operating factor
Mechanical service life, DC	3×10^7 cycles
Standards/regulations	IEC 60664 , EN 50178
Degree of pollution/surge voltage category	2 / III
Mounting position/mounting	any / In rows with zero spacing
Connection data solid/stranded/AWG	0.14 ... 1.5 mm ² / 0.14 ... 1.5 mm ² / 26 - 16
Dimensions	16 mm / 93 mm / 75 mm
EMC note	Class A product, see page 605

Ordering data

Description	Input voltage U_N	Type	Order No.	Pcs./ Pkt.
Coupling relay modules for high inrush currents				
with Push-in connection	① 24 V DC	RIF-1-RPT-LDP-24DC/1IC	2909884	10
with screw connection	② 24 V DC	RIF-1-RSC-LDP-24DC/1IC	2909885	10

Operating voltage range

Curve A

Maximum permissible continuous voltage U_{max} with limiting continuous current on the contact side (see relevant technical data).

Curve B

Minimum permitted pick-up voltage U_{op} after pre-excitation (see relevant technical data).

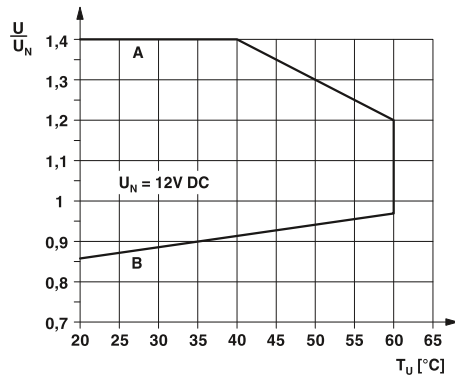

Interrupting rating

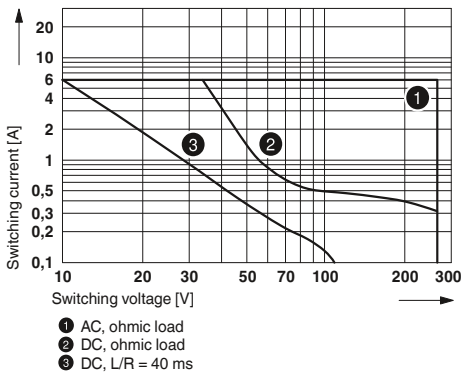

Basic behavior of capacitive loads:

- Very high input current
- Voltage increases with an e-function

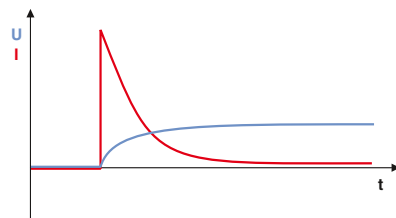

Relay modules

Industrial relay system - RIFLINE complete

Fully mounted RIF-2 relay modules

Fully mounted RIF-2 relay modules, consisting of:

- Relay base with Push-in connection
- 2 or 4-PDT industrial relay
- Relay retaining bracket
- Varistor interference suppression module (AC types only)

The advantages:

- Relay with lockable manual operation and status LED
- With DC types, freewheeling diode is integrated into relay
- Mechanical switch position indicator
- Logical contact arrangement thanks to 1/3-level relay base
- Professional bridging of adjacent modules saves wiring time
- For FBS 2-6 plug-in bridges for the input side (A2), see page 366.



2-PDT industrial relay module with Push-in connection and manual operation

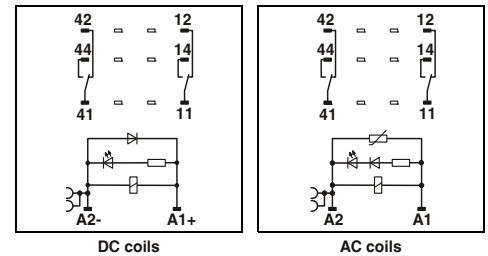

DC coils

AC coils

Technical data

	①	②	③	④
Input data	see diagram			
Permissible range (with reference to U_N)	42	66	13	6.5
Typical input current at U_N	[mA]	13	5 - 15	5 - 15
Typical response time at U_N	[ms]	14	5 - 20	5 - 20
Typical release time at U_N	[ms]	Yellow LED, Varistor		
Input circuit AC	Yellow LED, Damping diode			
Input circuit DC				
Output data	2 PDT			
Contact type	AgNi			
Contact material	250 V AC/DC			
Max. switching voltage	5 V (At 24 mA)			
Minimum switching voltage	10 A (see diagram)			
Limiting continuous current	30 A (20 ms, N/O contact)			
Maximum switch-on current AC	30 A (20 ms, N/O contact)			
Maximum switch-on current DC	5 mA (at 24 V)			
Minimum switching current				
General data	2.5 kV _{rms} (50 Hz, 1 min.)			
Test voltage (winding / contact)	-40 °C ... 50 °C			
Ambient temperature (operation), AC	-40 °C ... 60 °C			
Ambient temperature (operation), DC	100% operating factor			
Nominal operating mode	Approx. 2x 10 ⁷ cycles			
Mechanical service life, AC	Approx. 2x 10 ⁷ cycles			
Mechanical service life, DC	DIN EN 50178			
Standards/regulations	2 / III			
Degree of pollution/surge voltage category				
Mounting position/mounting	any / In rows with zero spacing			
Connection data solid/stranded/AWG	0.14 ... 1.5 mm ² / 0.14 ... 1.5 mm ² / 26 - 16			
Dimensions	31 mm / 96 mm / 75 mm			
W / H / D	Class A product, see page 605			
EMC note				

Ordering data

Description	Input voltage U_N	Type	Order No.	Pcs./Pkt.
Pre-assembled coupling relay modules with power contact relay and Push-in connection	① 24 V DC	RIF-2-RPT-LDP-24DC/2X21	2903315	10
	② 24 V AC	RIF-2-RPT-LV-24AC/2X21	2903313	10
	③ 120 V AC	RIF-2-RPT-LV-120AC/2X21	2903311	10
	④ 230 V AC	RIF-2-RPT-LV-230AC/2X21	2903310	10



4-PDT industrial relay module with Push-in connection and manual operation



RIF-2-RPT.../2X21 (2-PDT)

Operating voltage range

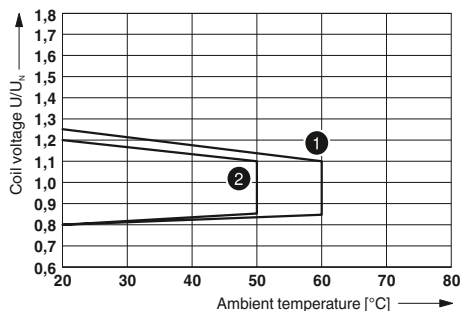

- ① DC coil (observe contact derating)
- ② AC coil (observe contact derating)

Interrupting rating

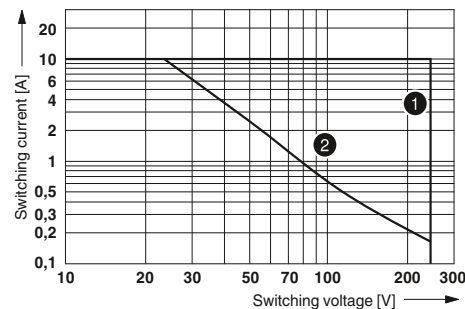

- ① AC, ohmic load
- ② DC, ohmic load

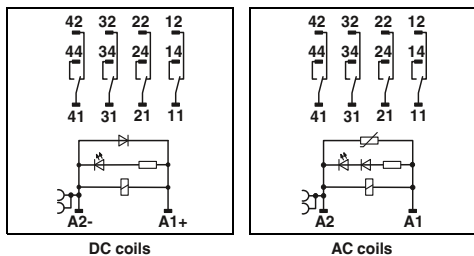

Contact derating

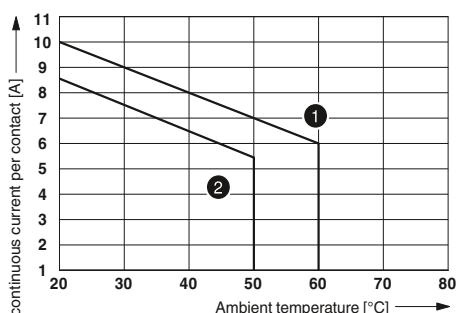

- ① DC coil
- ② AC coil

Electrical service life

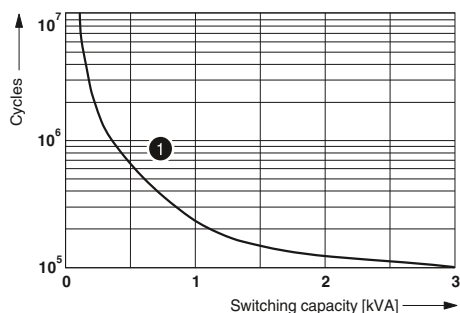

- ① 250 V AC, ohmic load

Technical data

①	②	③	④
see diagram			
42	66	13	6.5
13	5 - 15	5 - 15	5 - 15
14	5 - 20	5 - 20	5 - 20
Yellow LED, Varistor			
Yellow LED, Damping diode			

4 PDT
 AgNi
 250 V AC/DC
 5 V (At 24 mA)
 6 A (see diagram)
 16 A (20 ms, N/O contact)
 16 A (20 ms, N/O contact)
 5 mA (at 24 V)

2.5 kV_{rms} (50 Hz, 1 min.)
 -40 °C ... 50 °C
 -40 °C ... 60 °C
 100% operating factor
 Approx. 2x 10⁷ cycles
 Approx. 2x 10⁷ cycles
 DIN EN 50178
 2 / II

any / In rows with zero spacing
 0.14 ... 1.5 mm² / 0.14 ... 1.5 mm² / 26 - 16
 31 mm / 96 mm / 75 mm
 Class A product, see page 605

Ordering data

Type	Order No.	Pcs./ Pkt.
RIF-2-RPT-LDP-24DC/4X21	2903308	10
RIF-2-RPT-LV-24AC/4X21	2903306	10
RIF-2-RPT-LV-120AC/4X21	2903305	10
RIF-2-RPT-LV-230AC/4X21	2903304	10

RIF-2-RPT.../4X21 (4-PDT)

Operating voltage range

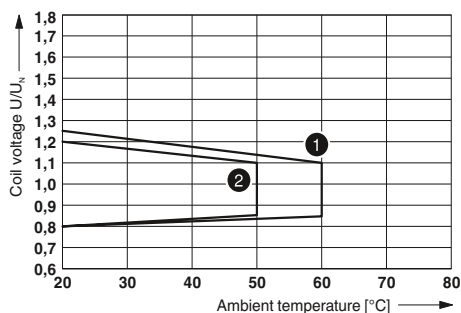

- ① DC coil (observe contact derating)
- ② AC coil (observe contact derating)

Interrupting rating

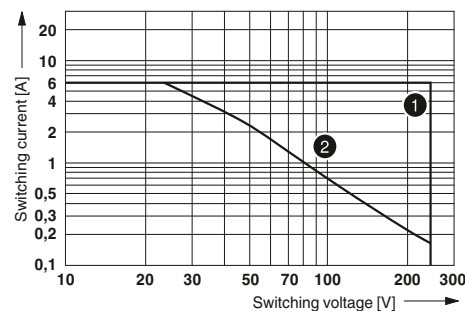

- ① AC, ohmic load
- ② DC, ohmic load

Contact derating

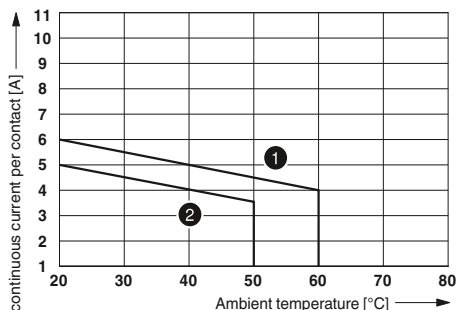

- ① DC coil
- ② AC coil

Electrical service life

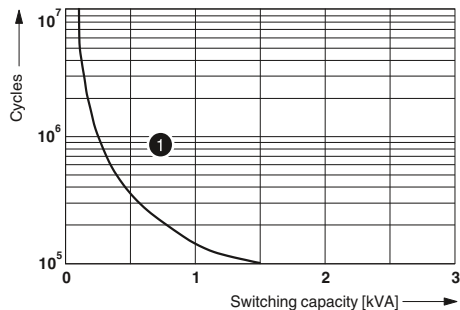

- ① 250 V AC, ohmic load

Relay modules

Industrial relay system - RIFLINE complete

Fully mounted RIF-2 relay modules

Fully mounted RIF-2 relay modules, consisting of:

- Relay base with screw connection
- 2 or 4-PDT relay
- Relay retaining bracket
- Interference suppression module (AC types only)

The advantages:

- Relay with lockable manual operation and status LED
- With DC types, freewheeling diode is integrated into relay
- Mechanical switch position indicator
- Logical contact arrangement thanks to 1/3-level relay base
- Professional bridging of adjacent modules saves wiring time
- For FBS 2-6 plug-in bridges for the input side (A2), see page 366.



new

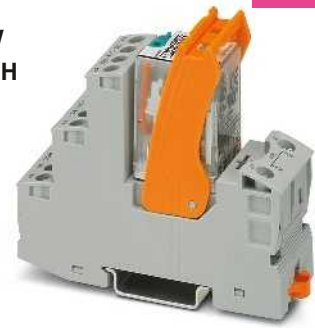

2-PDT industrial relay module with screw connection and manual operation

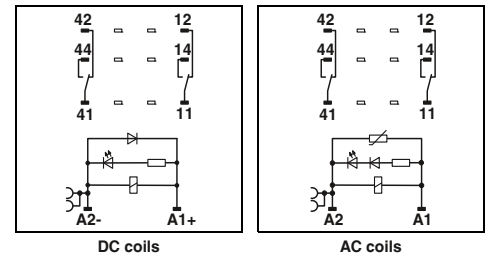

Input data	
Permissible range (with reference to U_N)	
Typical input current at U_N	[mA]
Typical response time at U_N	[ms]
Typical release time at U_N	[ms]
Input circuit AC	
Input circuit DC	
Output data	
Contact type	
Contact material	
Max. switching voltage	
Minimum switching voltage	
Limiting continuous current	
Maximum switch-on current AC	
Maximum switch-on current DC	
Minimum switching current	
General data	
Test voltage (winding / contact)	
Ambient temperature (operation), AC	
Ambient temperature (operation), DC	
Nominal operating mode	
Mechanical service life, AC	
Mechanical service life, DC	
Standards/regulations	
Degree of pollution/surge voltage category	
Mounting position/mounting	
Connection data solid/stranded/AWG	
Dimensions	W / H / D

Technical data

①	②	③	④	⑤
see diagram				
42	7.5	66	13	6.5
13	13	5 - 15	5 - 15	5 - 15
14	14	5 - 20	5 - 20	5 - 20
Yellow LED, Varistor				
Yellow LED, Damping diode				
2 PDT				
AgNi				
250 V AC/DC				
5 V (At 24 mA)				
10 A (see diagram)				
30 A (20 ms, N/O contact)				
30 A (20 ms, N/O contact)				
5 mA (at 24 V)				
2.5 kV _{rms} (50 Hz, 1 min.)				
-40 °C ... 50 °C				
-40 °C ... 60 °C				
100% operating factor				
Approx. 2x 10 ⁷ cycles				
Approx. 2x 10 ⁷ cycles				
DIN EN 50178				
2 / III				
any / In rows with zero spacing				
0.14 ... 6 mm ² / 0.14 ... 4 mm ² / 26 - 10				
27 mm / 89 mm / 75 mm				

Ordering data

Description	Input voltage U_N	Type	Order No.	Pcs./ Pkt.
Pre-assembled coupling relay modules with power contact relay and screw connection				
	① 24 V DC	RIF-2-RSC-LDP-24DC/2X21	2903326	10
	② 125 V DC	RIF-2-RSC-LDP-125DC/2X21	2903324	10
	③ 24 V AC	RIF-2-RSC-LV-24AC/2X21	2903323	10
	④ 120 V AC	RIF-2-RSC-LV-120AC/2X21	2903322	10
	⑤ 230 V AC	RIF-2-RSC-LV-230AC/2X21	2903321	10

new



4-PDT industrial relay module with screw connection and manual operation

RIF-2-RSC.../2X21 (2-PDT)

Operating voltage range

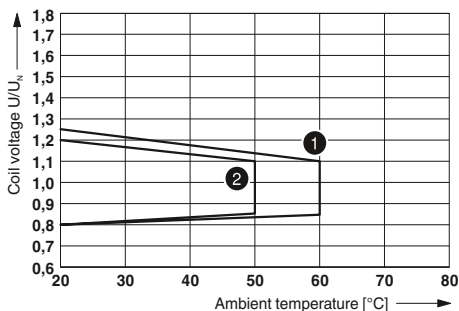

- 1 DC coil (observe contact derating)
- 2 AC coil (observe contact derating)

Interrupting rating

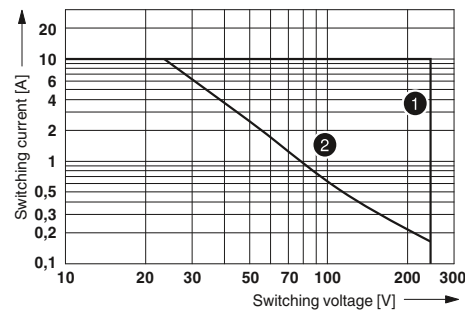

- 1 AC, ohmic load
- 2 DC, ohmic load

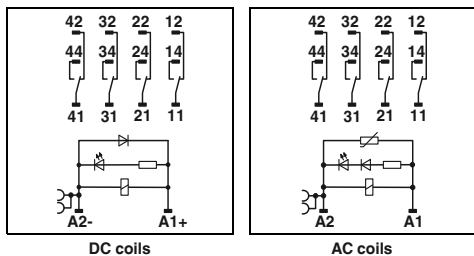

Contact derating

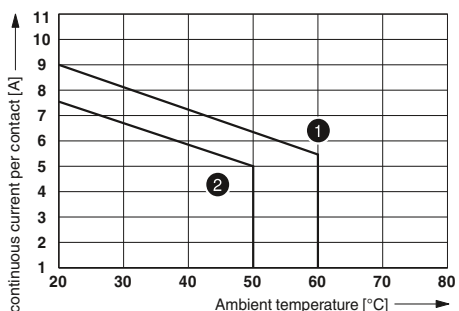

- 1 DC coil
- 2 AC coil

Electrical service life

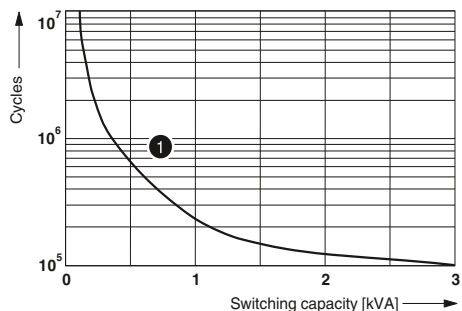

- 1 250 V AC, ohmic load

Technical data

①	②	③	④	⑤
see diagram				
42	7.5	66	13	6.5
13	13	5 - 15	5 - 15	5 - 15
14	14	5 - 20	5 - 20	5 - 20

Yellow LED, Varistor
Yellow LED, Damping diode

4 PDT
AgNi
250 V AC/DC
5 V (At 24 mA)
6 A (see diagram)
16 A (20 ms, N/O contact)
16 A (20 ms, N/O contact)
5 mA (at 24 V)

2.5 kV_{rms} (50 Hz, 1 min.)
-40 °C ... 50 °C
-40 °C ... 60 °C
100% operating factor
Approx. 2x 10⁷ cycles
Approx. 2x 10⁷ cycles
DIN EN 50178
2 / II

any / In rows with zero spacing
0.14 ... 6 mm² / 0.14 ... 4 mm² / 26 - 10
27 mm / 89 mm / 75 mm

Ordering data

Type	Order No.	Pcs./ Pkt.
RIF-2-RSC-LDP-24DC/4X21	2903320	10
RIF-2-RSC-LDP-125DC/4X21	2903319	10
RIF-2-RSC-LV-24AC/4X21	2903318	10
RIF-2-RSC-LV-120AC/4X21	2903317	10
RIF-2-RSC-LV-230AC/4X21	2903316	10

RIF-2-RSC.../4X21 (4-PDT)

Operating voltage range

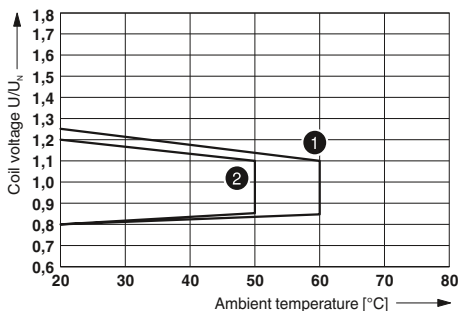

- 1 DC coil (observe contact derating)
- 2 AC coil (observe contact derating)

Interrupting rating

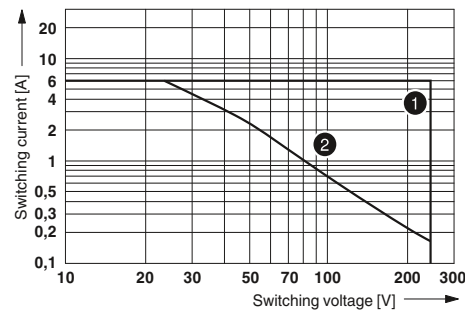

- 1 AC, ohmic load
- 2 DC, ohmic load

Contact derating

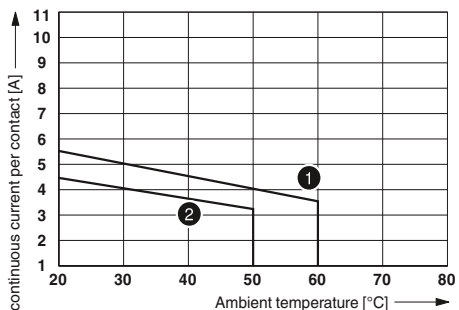

- 1 DC coil
- 2 AC coil

Electrical service life

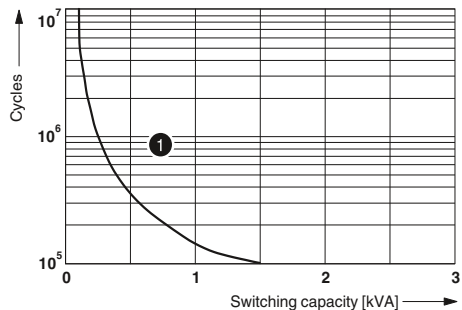

- 1 250 V AC, ohmic load

Relay modules

Industrial relay system - RIFLINE complete

Fully mounted RIF-3 relay modules

Fully mounted RIF-3 relay modules, consisting of:

- Relay base with Push-in connection
- 2 or 3-PDT octal relay
- Relay retaining bracket
- Interference suppression module (AC types only)

The advantages:

- Relay with lockable manual operation and status LED
- With DC types, freewheeling diode is integrated into relay
- Mechanical switch position indicator
- Logical contact arrangement thanks to 1/3-level relay base
- Professional bridging of adjacent modules saves wiring time
- For FBS 2-6 plug-in bridges for the input side (A2), see page 366.



2-PDT octal relay module with Push-in connection and manual operation

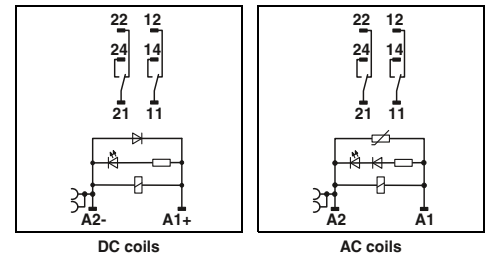

DC coils

AC coils

Technical data

Input data	①	②	③
Permissible range (with reference to U_N)	see diagram		
Typical input current at U_N	[mA]	60	23 13
Typical response time at U_N	[ms]	18	5 - 15 5 - 15
Typical release time at U_N	[ms]	20	5 - 20 5 - 20
Input circuit AC	Yellow LED, Varistor		
Input circuit DC	Yellow LED, Damping diode		
Output data			
Contact type	2 PDT		
Contact material	AgNi		
Max. switching voltage	250 V AC/DC		
Minimum switching voltage	10 V (At 24 mA)		
Limiting continuous current	10 A (see diagram)		
Maximum switch-on current AC	30 A (20 ms, N/O contact)		
Maximum switch-on current DC	30 A (20 ms, N/O contact)		
Minimum switching current	10 mA (at 24 V)		
General data			
Test voltage (winding / contact)	2.5 kV _{rms} (50 Hz, 1 min.)		
Ambient temperature (operation), AC	-40 °C ... 50 °C		
Ambient temperature (operation), DC	-40 °C ... 60 °C		
Nominal operating mode	100% operating factor		
Mechanical service life, AC	Approx. 2x 10 ⁷ cycles		
Mechanical service life, DC	Approx. 2x 10 ⁷ cycles		
Standards/regulations	DIN EN 50178		
Degree of pollution/surge voltage category	2 / III		
Mounting position/mounting	any / In rows with zero spacing		
Connection data solid/stranded/AWG	0.14 ... 1.5 mm ² / 0.14 ... 1.5 mm ² / 26 - 16		
Dimensions	W / H / D 40 mm / 103 mm / 90 mm		
EMC note	Class A product, see page 605		

Ordering data

Description	Input voltage U_N	Type	Order No.	Pcs./Pkt.
Pre-assembled coupling relay modules with power contact relay and Push-in connection	① 24 V DC	RIF-3-RPT-LDP-24DC/2X21	2903297	5
	② 120 V AC	RIF-3-RPT-LV-120AC/2X21	2903296	5
	③ 230 V AC	RIF-3-RPT-LV-230AC/2X21	2903295	5



3-PDT octal relay module with Push-in connection and manual operation



RIF-3-RPT.../2X21 (2-PDT)

Operating voltage range

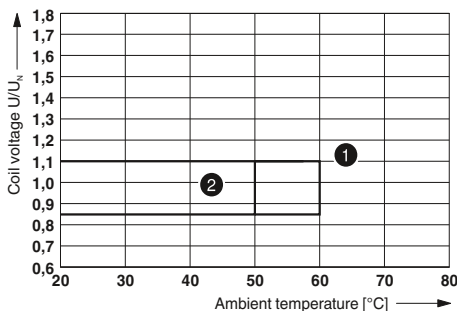

- ① DC coil (observe contact derating)
- ② AC coil (observe contact derating)

Interrupting rating

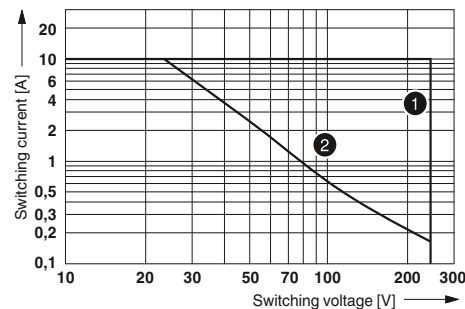

- ① AC, ohmic load
- ② DC, ohmic load

Contact derating

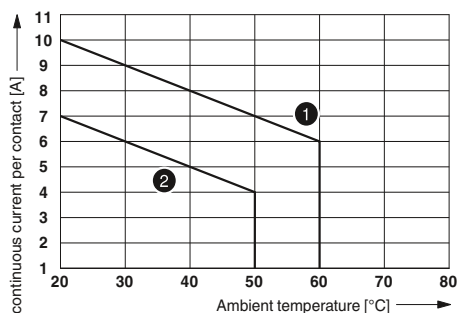

- ① DC coil
- ② AC coil

Electrical service life

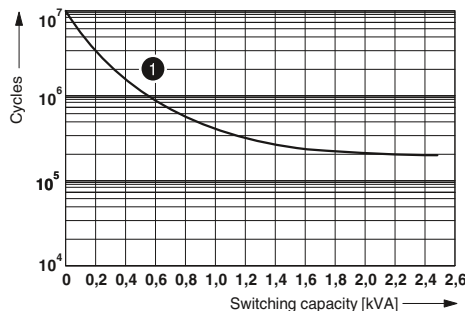

- ① 250 V AC, ohmic load

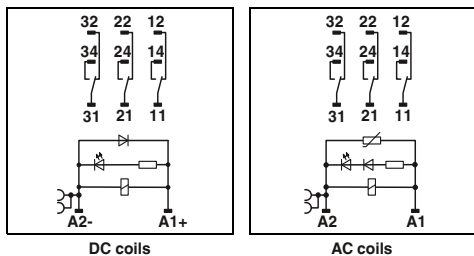

Technical data

①	②	③
see diagram		
60	23	13
18	5 - 15	5 - 15
20	5 - 20	5 - 20
Yellow LED, Varistor		
Yellow LED, Damping diode		

3 PDT
AgNi
250 V AC/DC
10 V (At 24 mA)
8.5 A (see diagram)
30 A (20 ms, N/O contact)
30 A (20 ms, N/O contact)
10 mA (at 24 V)

2.5 kV_{rms} (50 Hz, 1 min.)
-40 °C ... 50 °C
-40 °C ... 60 °C
100% operating factor
Approx. 2x 10⁷ cycles
Approx. 2x 10⁷ cycles
DIN EN 50178
2 / III

any / In rows with zero spacing
0.14 ... 1.5 mm² / 0.14 ... 1.5 mm² / 26 - 16
40 mm / 103 mm / 90 mm
Class A product, see page 605

Ordering data

Type	Order No.	Pcs./ Pkt.
RIF-3-RPT-LDP-24DC/3X21	2903294	5
RIF-3-RPT-LV-120AC/3X21	2903293	5
RIF-3-RPT-LV-230AC/3X21	2903292	5

RIF-3-RPT.../3X21 (3-PDT)

Operating voltage range

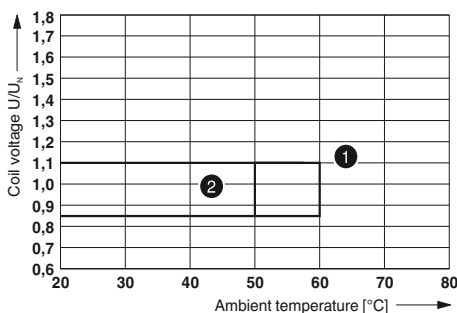

- ① DC coil (observe contact derating)
- ② AC coil (observe contact derating)

Interrupting rating

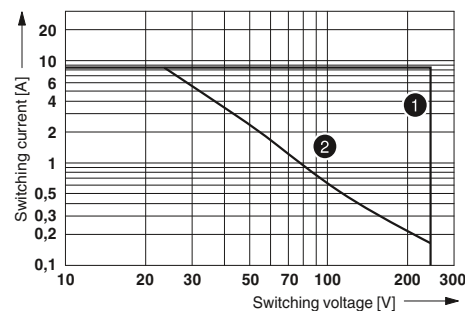

- ① AC, ohmic load
- ② DC, ohmic load

Contact derating

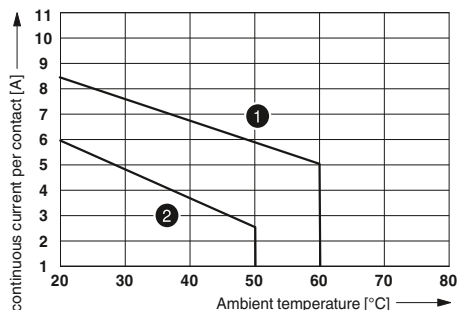

- ① DC coil
- ② AC coil

Electrical service life

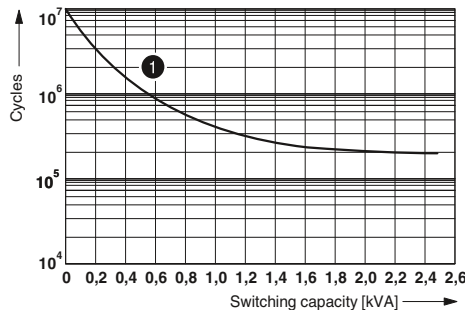

- ① 250 V AC, ohmic load

Relay modules

Industrial relay system - RIFLINE complete

Fully mounted RIF-3 relay modules

Fully mounted RIF-3 relay modules, consisting of:

- Relay base with screw connection
- 2 or 3-PDT octal relay
- Relay retaining bracket
- Varistor interference suppression module (AC types only)

The advantages:

- Relay with lockable manual operation and status LED
- With DC types, freewheeling diode is integrated into relay
- Mechanical switch position indicator
- Logical contact arrangement thanks to 1/3-level relay base
- Professional bridging of adjacent modules saves wiring time
- For FBS 2-6 plug-in bridges for the input side (A2), see page 366.



new



2-PDT octal relay module with screw connection and manual operation

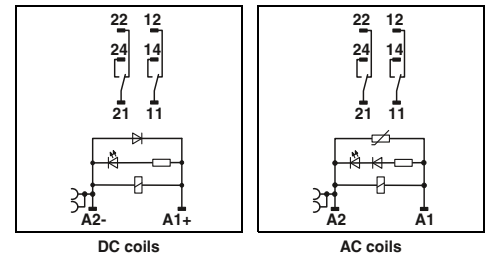

Input data	
Permissible range (with reference to U_N)	
Typical input current at U_N	[mA]
Typical response time at U_N	[ms]
Typical release time at U_N	[ms]
Input circuit AC	
Input circuit DC	
Output data	
Contact type	
Contact material	
Max. switching voltage	
Minimum switching voltage	
Limiting continuous current	
Maximum switch-on current AC	
Maximum switch-on current DC	
Minimum switching current	
General data	
Test voltage (winding / contact)	
Ambient temperature (operation), AC	
Ambient temperature (operation), DC	
Nominal operating mode	
Mechanical service life, AC	
Mechanical service life, DC	
Standards/regulations	
Degree of pollution/surge voltage category	
Mounting position/mounting	
Connection data solid/stranded/AWG	
Dimensions	W / H / D
EMC note	

Technical data		
①	②	③
see diagram		
60	23	13
18	5 - 15	5 - 15
20	5 - 20	5 - 20
Yellow LED, Varistor		
Yellow LED, Damping diode		
2 PDT		
AgNi		
250 V AC/DC		
10 V (At 24 mA)		
10 A (see diagram)		
30 A (20 ms, N/O contact)		
30 A (20 ms, N/O contact)		
10 mA (at 24 V)		
2.5 kV _{rms} (50 Hz, 1 min.)		
-40 °C ... 50 °C		
-40 °C ... 60 °C		
100% operating factor		
Approx. 2x 10 ⁷ cycles		
Approx. 2x 10 ⁷ cycles		
DIN EN 50178		
2 / III		
any / In rows with zero spacing		
0.14 ... 6 mm ² / 0.14 ... 4 mm ² / 26 - 10		
40 mm / 96 mm / 90 mm		
Class A product, see page 605		

Description	Input voltage U_N
Pre-assembled coupling relay modules with power contact relay and screw connection	① 24 V DC
	② 120 V AC
	③ 230 V AC

Ordering data		
Type	Order No.	Pcs./Pkt.
RIF-3-RSC-LDP-24DC/2X21	2903303	5
RIF-3-RSC-LV-120AC/2X21	2903302	5
RIF-3-RSC-LV-230AC/2X21	2903301	5

new



3-PDT octal relay module with screw connection and manual operation

RIF-3-RSC.../2X21 (2-PDT)

Operating voltage range

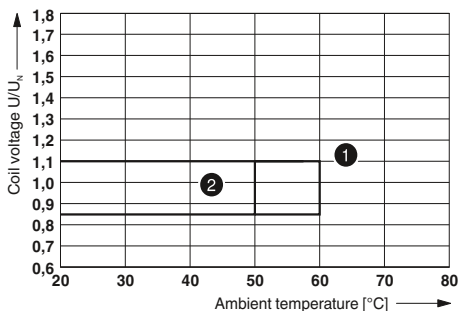

- ① DC coil (observe contact derating)
- ② AC coil (observe contact derating)

Interrupting rating

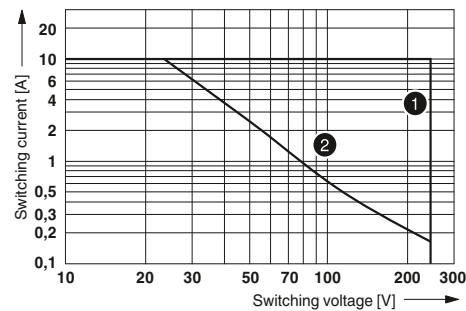

- ① AC, ohmic load
- ② DC, ohmic load

Contact derating

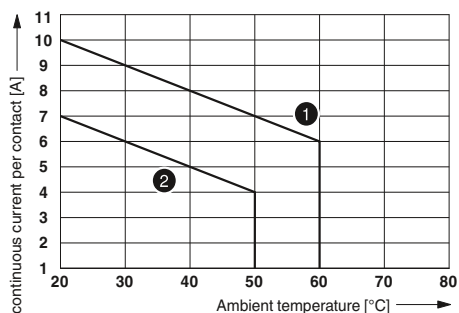

- ① DC coil
- ② AC coil

Electrical service life

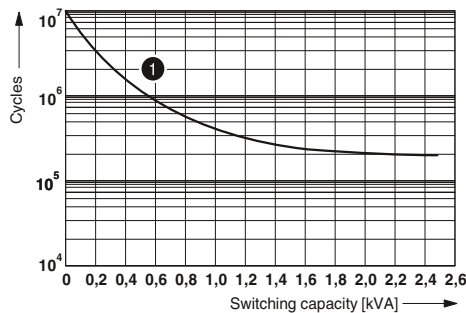

- ① 250 V AC, ohmic load

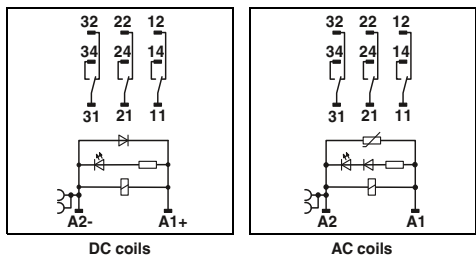

DC coils

AC coils

Technical data

- ① see diagram
- ② 60 23 13
- ③ 18 5 - 15 5 - 15
- 20 5 - 20 5 - 20
- Yellow LED, Varistor
- Yellow LED, Damping diode

- 3 PDT
- AgNi
- 250 V AC/DC
- 10 V (At 24 mA)
- 8.5 A (see diagram)
- 30 A (20 ms, N/O contact)
- 30 A (20 ms, N/O contact)
- 10 mA (at 24 V)

- 2.5 kV_{rms} (50 Hz, 1 min.)
- 40 °C ... 50 °C
- 40 °C ... 60 °C
- 100% operating factor
- Approx. 2x 10⁷ cycles
- Approx. 2x 10⁷ cycles
- DIN EN 50178
- 2 / III

- any / In rows with zero spacing
- 0.14 ... 6 mm² / 0.14 ... 4 mm² / 26 - 10
- 40 mm / 96 mm / 90 mm
- Class A product, see page 605

Ordering data

Type	Order No.	Pcs./ Pkt.
RIF-3-RSC-LDP-24DC/3X21	2903300	5
RIF-3-RSC-LV-120AC/3X21	2903299	5
RIF-3-RSC-LV-230AC/3X21	2903298	5

RIF-3-RSC.../3X21 (3-PDT)

Operating voltage range

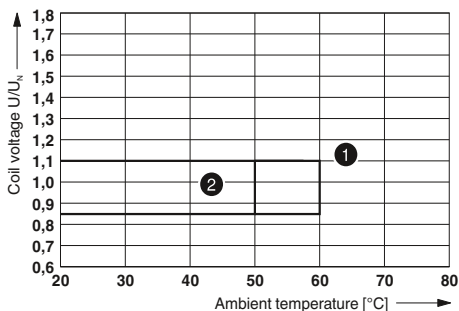

- ① DC coil (observe contact derating)
- ② AC coil (observe contact derating)

Interrupting rating

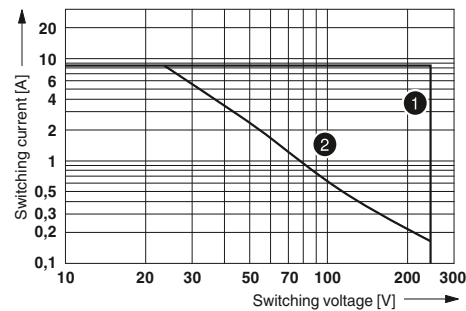

- ① AC, ohmic load
- ② DC, ohmic load

Contact derating

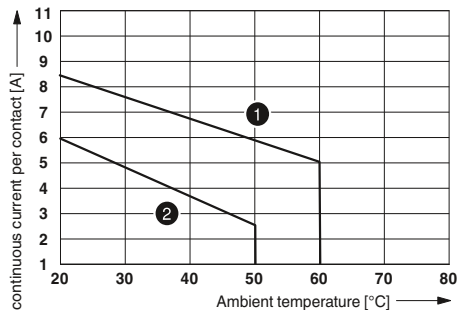

- ① DC coil
- ② AC coil

Electrical service life

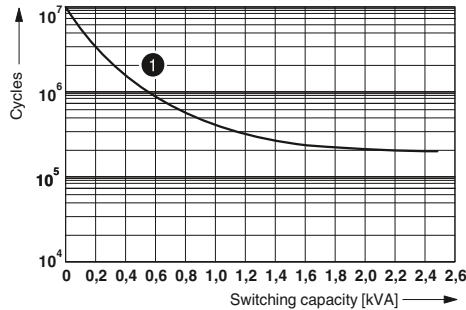

- ① 250 V AC, ohmic load

Relay modules

Industrial relay system - RIFLINE complete

Fully mounted RIF-4 relay modules

Fully mounted RIF-4 relay modules, consisting of:

- Relay base with Push-in connection
- 2 or 3-PDT high-power relay
- Relay retaining bracket
- Varistor interference suppression module (AC types only)

The advantages:

- Logical contact arrangement thanks to 1/3-level relay base
- Professional bridging of adjacent modules saves wiring time
- For FBS 2-6 plug-in bridges for the input side (A2), see page 366.



2-PDT high-power relay module with Push-in connection

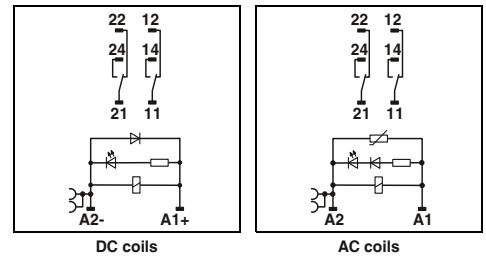

Technical data

	①	②	③
Input data	see diagram		
Permissible range (with reference to U_N)			
Typical input current at U_N	[mA]	56	24 14
Typical response time at U_N	[ms]	20	5 - 25 5 - 25
Typical release time at U_N	[ms]	20	5 - 20 5 - 20
Input circuit AC	Yellow LED, Varistor		
Input circuit DC	Yellow LED, Damping diode		
Output data			
Contact type	2 PDT		
Contact material	AgNi		
Max. switching voltage	440 V AC / 250 V DC		
Minimum switching voltage	10 V (At 24 mA)		
Limiting continuous current	11 A (see diagram)		
Maximum switch-on current AC	50 A (20 ms, N/O contact)		
Maximum switch-on current DC	50 A (20 ms, N/O contact)		
Minimum switching current	10 mA (at 24 V)		
Maximum interrupting rating, ohmic load	250 V AC	2500 VA	
	440 V AC	4000 VA	
Motor load according to UL 508		1/3 HP, 120 V AC (single-phase AC motor)	1/2 HP, 240 V AC (single-phase AC motor)
General data			
Test voltage (winding / contact)	2.5 kV _{rms} (50 Hz, 1 min.)		
Ambient temperature (operation), AC	-40 °C ... 40 °C		
Ambient temperature (operation), DC	-40 °C ... 60 °C		
Nominal operating mode	100% operating factor		
Mechanical service life, AC	Approx. 10 ⁷ cycles		
Mechanical service life, DC	Approx. 10 ⁷ cycles		
Standards/regulations	DIN EN 50178		
Degree of pollution/surge voltage category	2 / III		
Mounting position/mounting	any / In rows with zero spacing		
Connection data solid/stranded/AWG			
Input side	0.14 ... 1.5 mm ² / 0.14 ... 1.5 mm ² / 26 - 16		
Output side	0.14 ... 2.5 mm ² / 0.14 ... 2.5 mm ² / 26 - 14		
Dimensions	43 mm / 111 mm / 90 mm		
EMC note	Class A product, see page 605		

Ordering data

Description	Input voltage U_N	Type	Order No.	Pcs./ Pkt.
Pre-assembled coupling relay modules with power contact relay and Push-in connection	① 24 V DC	RIF-4-RPT-LDP-24DC/2X21	2903281	5
	② 120 V AC	RIF-4-RPT-LV-120AC/2X21	2903280	5
	③ 230 V AC	RIF-4-RPT-LV-230AC/2X21	2903279	5



3-PDT high-power relay module with Push-in connection



RIF-4-RPT.../2X21 (2-PDT)

Operating voltage range

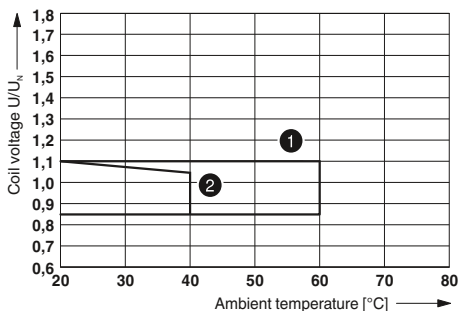

- ① DC coil (observe contact derating)
- ② AC coil (observe contact derating)

Interrupting rating

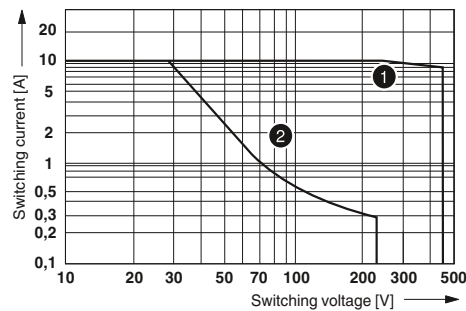

- ① AC, ohmic load
- ② DC, ohmic load

Contact derating

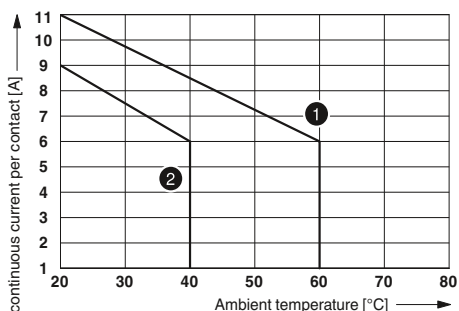

- ① DC coil
- ② AC coil

Electrical service life

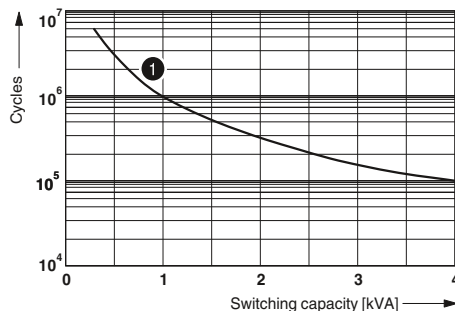

- ① 250 V AC, ohmic load

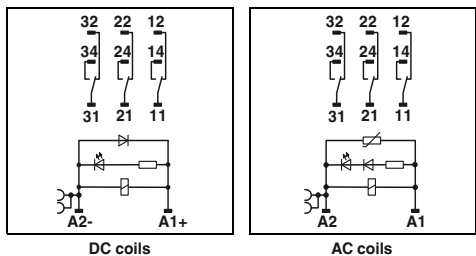

Technical data

①	②	③
see diagram		
56	24	14
20	5 - 25	5 - 25
20	5 - 20	5 - 20
Yellow LED, Varistor		
Yellow LED, Damping diode		

3 PDT
 AgNi
 440 V AC / 250 V DC
 10 V (At 24 mA)
 10 A (see diagram)
 50 A (20 ms, N/O contact)
 50 A (20 ms, N/O contact)
 10 mA (at 24 V)

2500 VA
 4000 VA
 1/3 HP, 120 V AC (single-phase AC motor)
 1/2 HP, 240 V AC (single-phase AC motor)
 1/2 HP, 240 V AC (three-phase induction motor)

2.5 kV_{rms} (50 Hz, 1 min.)
 -40 °C ... 40 °C
 -40 °C ... 60 °C
 100% operating factor
 Approx. 10⁷ cycles
 Approx. 10⁷ cycles
 DIN EN 50178
 2 / III

any / In rows with zero spacing

0.14 ... 1.5 mm² / 0.14 ... 1.5 mm² / 26 - 16
 0.14 ... 2.5 mm² / 0.14 ... 2.5 mm² / 26 - 14
 43 mm / 111 mm / 90 mm
 Class A product, see page 605

Ordering data

Type	Order No.	Pcs./ Pkt.
RIF-4-RPT-LDP-24DC/3X21	2903278	5
RIF-4-RPT-LV-120AC/3X21	2903277	5
RIF-4-RPT-LV-230AC/3X21	2903276	5

RIF-4-RPT.../3X21 (3-PDT)

Operating voltage range

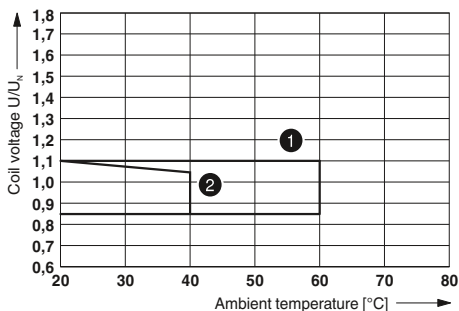

- ① DC coil (observe contact derating)
- ② AC coil (observe contact derating)

Interrupting rating

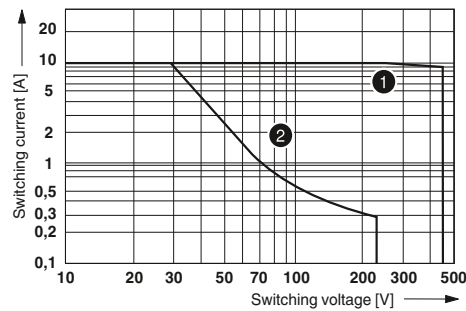

- ① AC, ohmic load
- ② DC, ohmic load

Contact derating

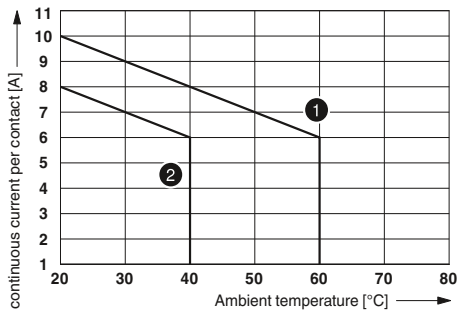

- ① DC coil
- ② AC coil

Electrical service life

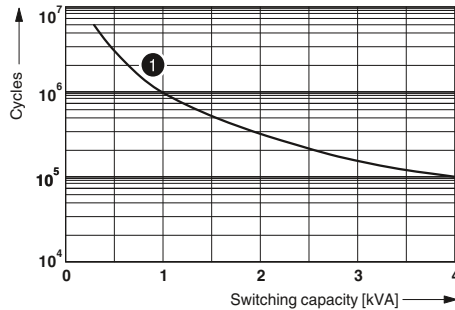

- ① 250 V AC, ohmic load

Relay modules

Industrial relay system - RIFLINE complete

Fully mounted RIF-4 relay modules

Fully mounted RIF-4 relay modules, consisting of:

- Relay base with Push-in connection
- 3-N/O high-power relay
- Relay retaining bracket
- Varistor interference suppression module (AC types only)

The advantages:

- Logical contact arrangement thanks to 1/3-level relay base
- Full shutdown by means of ≥ 3 mm contact opening
- Professional bridging of adjacent modules saves wiring time
- For FBS 2-6 plug-in bridges for the input side (A2), see page 366.



3-N/O high-power relay module with Push-in connection

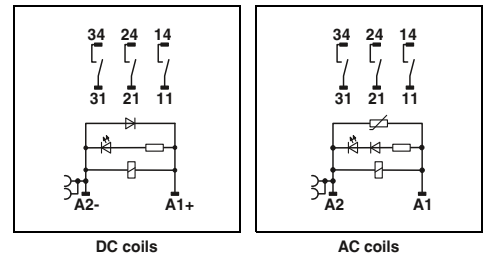

DC coils

AC coils

Technical data

	①	②	③
Input data	see diagram		
Permissible range (with reference to U_N)			
Typical input current at U_N	[mA]	70	24 14
Typical response time at U_N	[ms]	20	5 - 25 5 - 25
Typical release time at U_N	[ms]	20	5 - 20 5 - 20
Input circuit AC			Yellow LED, Varistor
Input circuit DC			Yellow LED, Damping diode
Output data			
Contact type	3 N/O contacts		
Contact material	AgNi		
Max. switching voltage	440 V AC / 250 V DC		
Minimum switching voltage	10 V (At 24 mA)		
Limiting continuous current	10 A (see diagram)		
Maximum switch-on current AC	50 A (20 ms, N/O contact)		
Maximum switch-on current DC	50 A (20 ms, N/O contact)		
Minimum switching current	10 mA (at 24 V)		
Maximum interrupting rating, ohmic load	250 V AC	2500 VA	
	440 V AC	4000 VA	
Motor load according to UL 508			1/3 HP, 120 V AC (single-phase AC motor) 1/2 HP, 240 V AC (single-phase AC motor) 1/2 HP, 240 V AC (three-phase induction motor)
General data			
Test voltage (winding / contact)	2.5 kV _{rms} (50 Hz, 1 min.)		
Ambient temperature (operation), AC	-40 °C ... 40 °C		
Ambient temperature (operation), DC	-40 °C ... 60 °C		
Nominal operating mode	100% operating factor		
Mechanical service life, AC	Approx. 10 ⁷ cycles		
Mechanical service life, DC	Approx. 10 ⁷ cycles		
Standards/regulations	DIN EN 50178		
Degree of pollution/surge voltage category	2 / III		
Mounting position/mounting	any / In rows with zero spacing		
Connection data solid/stranded/AWG			
Input side	0.14 ... 1.5 mm ² / 0.14 ... 1.5 mm ² / 26 - 16		
Output side	0.14 ... 2.5 mm ² / 0.14 ... 2.5 mm ² / 26 - 14		
Dimensions	W / H / D	43 mm / 111 mm / 90 mm	
EMC note	Class A product, see page 605		

Ordering data

Description	Input voltage U_N	Type	Order No.	Pcs./ Pkt.
Pre-assembled coupling relay modules with power contact relay and Push-in connection	① 24 V DC	RIF-4-RPT-LDP-24DC/3X1	2903275	5
	② 120 V AC	RIF-4-RPT-LV-120AC/3X1	2903274	5
	③ 230 V AC	RIF-4-RPT-LV-230AC/3X1	2903273	5

RIF-4-RPT.../3X1 (3-N/O)

Operating voltage range

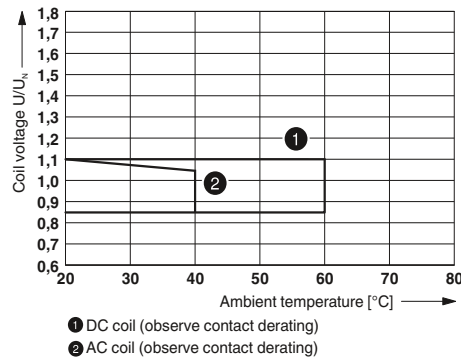

Interrupting rating

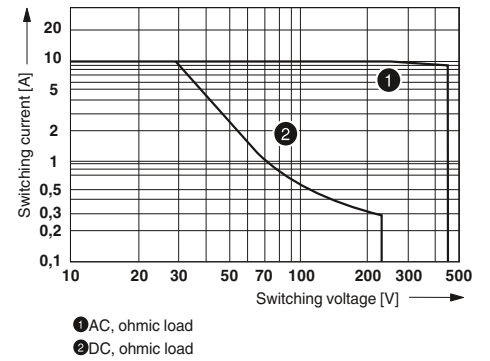

Contact derating

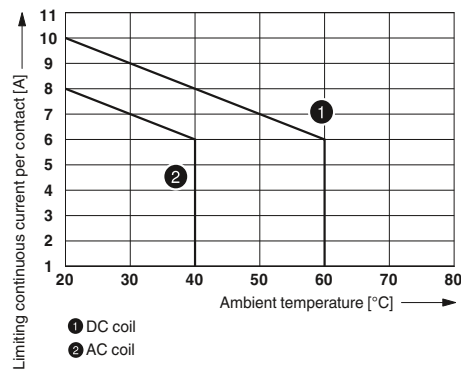

Electrical service life

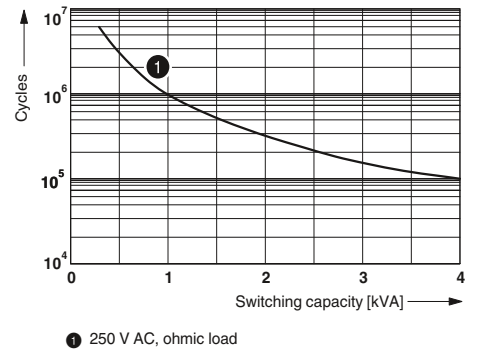

Relay modules

Industrial relay system - RIFLINE complete

Fully mounted RIF-4 relay modules

Fully mounted RIF-4 relay modules, consisting of:

- Relay base with screw connection
- 3-PDT high-power relay
- Relay retaining bracket
- Varistor interference suppression module (AC types only)

The advantages:

- Logical contact arrangement thanks to 1/3-level relay base
- Professional bridging of adjacent modules saves wiring time
- For FBS 2-6 plug-in bridges for the input side (A2), see page 366.



new

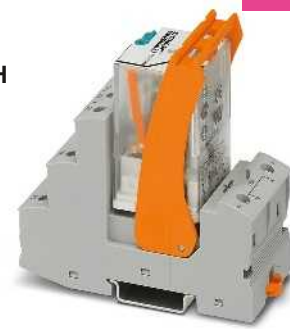

2-PDT high-power relay module with screw connection

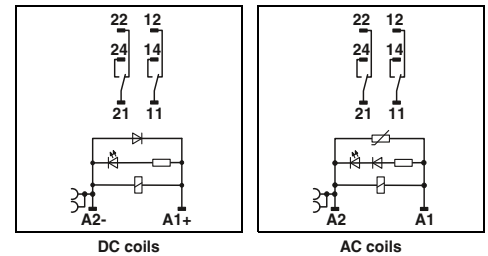

Input data	
Permissible range (with reference to U_N)	
Typical input current at U_N	[mA]
Typical response time at U_N	[ms]
Typical release time at U_N	[ms]
Input circuit AC	
Input circuit DC	
Output data	
Contact type	
Contact material	
Max. switching voltage	
Minimum switching voltage	
Limiting continuous current	
Maximum switch-on current AC	
Maximum switch-on current DC	
Minimum switching current	
Maximum interrupting rating, ohmic load	
	250 V AC
	440 V AC
Motor load according to UL 508	
General data	
Test voltage (winding / contact)	
Ambient temperature (operation), AC	
Ambient temperature (operation), DC	
Nominal operating mode	
Mechanical service life, AC	
Mechanical service life, DC	
Standards/regulations	
Degree of pollution/surge voltage category	
Mounting position/mounting	
Connection data solid/stranded/AWG	
Input side	
Output side	
Dimensions	W / H / D
EMC note	

Technical data		
①	②	③
see diagram		
56	24	14
20	5 - 25	5 - 25
20	5 - 20	5 - 20
Yellow LED, Varistor		
Yellow LED, Damping diode		
2 PDT		
AgNi		
440 V AC / 250 V DC		
10 V (At 24 mA)		
11 A (see diagram)		
50 A (20 ms, N/O contact)		
50 A (20 ms, N/O contact)		
10 mA (at 24 V)		
2500 VA		
4000 VA		
1/3 HP, 120 V AC (single-phase AC motor)		
1/2 HP, 240 V AC (single-phase AC motor)		

Ordering data				
Description	Input voltage U_N	Type	Order No.	Pcs./Pkt.
Pre-assembled coupling relay modules with power contact relay and screw connection				
	① 24 V DC	RIF-4-RSC-LDP-24DC/2X21	2903291	5
	② 120 V AC	RIF-4-RSC-LV-120AC/2X21	2903290	5
	③ 230 V AC	RIF-4-RSC-LV-230AC/2X21	2903289	5



new



3-PDT high-power relay module with screw connection

RIF-4-RSC.../2X21 (2-PDT)

Operating voltage range

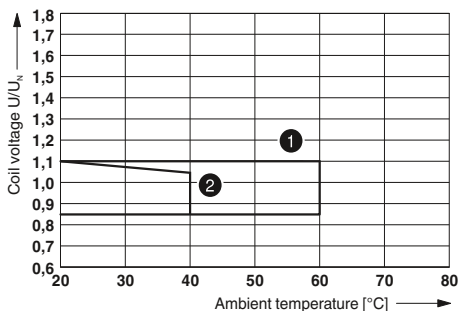

- ① DC coil (observe contact derating)
- ② AC coil (observe contact derating)

Interrupting rating

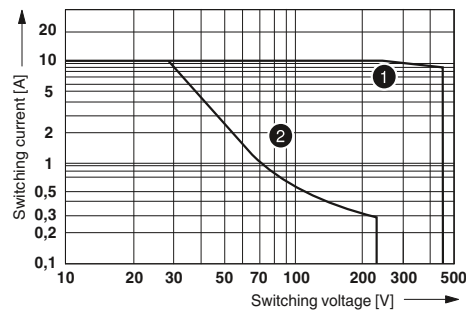

- ① AC, ohmic load
- ② DC, ohmic load

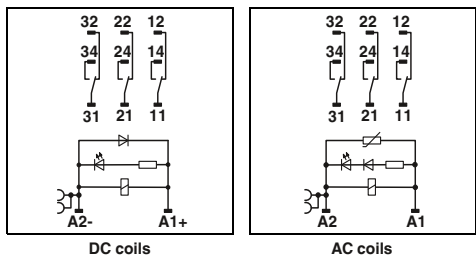

Contact derating

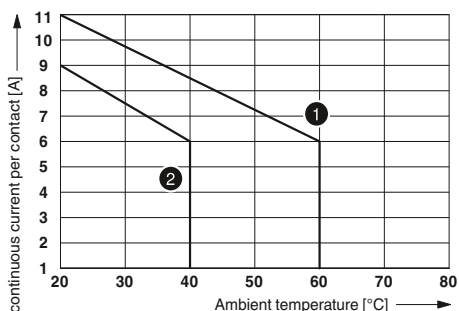

- ① DC coil
- ② AC coil

Electrical service life

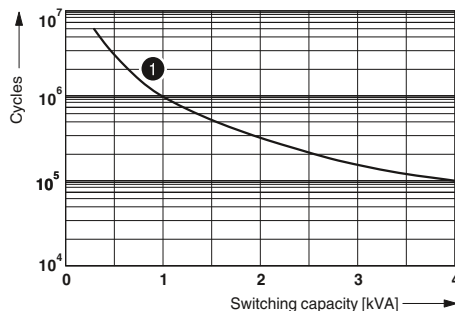

- ① 250 V AC, ohmic load

Technical data

- ① see diagram
- ② 56
- ③ 14
- 20 5 - 25 5 - 25
- 20 5 - 20 5 - 20
- Yellow LED, Varistor
- Yellow LED, Damping diode

- 3 PDT
- AgNi
- 440 V AC / 250 V DC
- 10 V (At 24 mA)
- 10 A (see diagram)
- 50 A (20 ms, N/O contact)
- 50 A (20 ms, N/O contact)
- 10 mA (at 24 V)
- 2500 VA
- 4000 VA
- 1/3 HP, 120 V AC (single-phase AC motor)
- 1/2 HP, 240 V AC (single-phase AC motor)
- 1/2 HP, 240 V AC (three-phase induction motor)

- 2.5 kV_{rms} (50 Hz, 1 min.)
- 40 °C ... 40 °C
- 40 °C ... 60 °C
- 100% operating factor
- Approx. 10⁷ cycles
- Approx. 10⁷ cycles
- DIN EN 50178
- 2 / III

any / In rows with zero spacing

- 0.14 ... 6 mm² / 0.14 ... 4 mm² / 26 - 10
- 0.14 ... 6 mm² / 0.14 ... 4 mm² / 26 - 10
- 44 mm / 96 mm / 91 mm
- Class A product, see page 605

Ordering data

Type	Order No.	Pcs./ Pkt.
RIF-4-RSC-LDP-24DC/3X21	2903288	5
RIF-4-RSC-LV-120AC/3X21	2903287	5
RIF-4-RSC-LV-230AC/3X21	2903285	5

RIF-4-RSC.../3X21 (3-PDT)

Operating voltage range

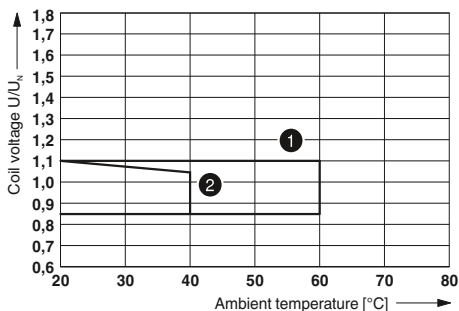

- ① DC coil (observe contact derating)
- ② AC coil (observe contact derating)

Interrupting rating

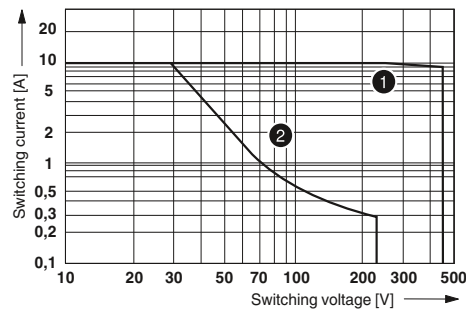

- ① AC, ohmic load
- ② DC, ohmic load

Contact derating

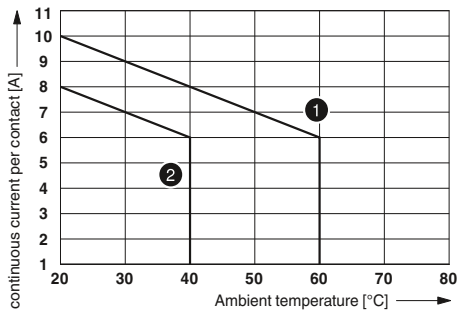

- ① DC coil
- ② AC coil

Electrical service life

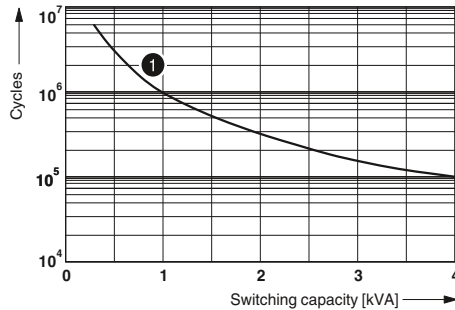

- ① 250 V AC, ohmic load

Relay modules

Industrial relay system - RIFLINE complete

Fully mounted RIF-4 relay modules

Fully mounted RIF-4 relay modules, consisting of:

- Relay base with screw connection
- 3-N/O high-power relay
- Relay retaining bracket
- Varistor interference suppression module (AC types only)

The advantages:

- Logical contact arrangement thanks to 1/3-level relay base
- Full shutdown by means of ≥ 3 mm contact opening
- Professional bridging of adjacent modules saves wiring time
- For FBS 2-6 plug-in bridges for the input side (A2), see page 366.



new

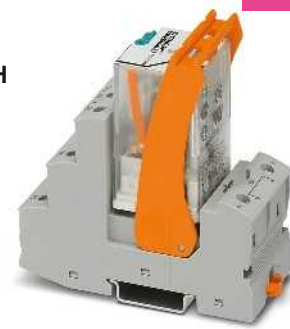

3-N/O high-power relay module with screw connection

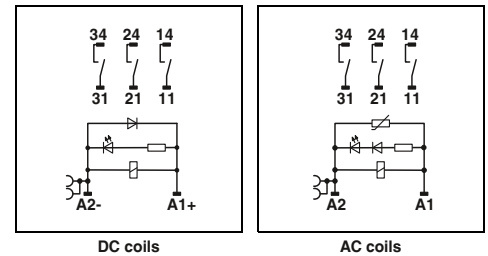

DC coils

AC coils

Technical data

	①	②	③
Input data	see diagram		
Permissible range (with reference to U_N)			
Typical input current at U_N	[mA]	70	24 14
Typical response time at U_N	[ms]	20	5 - 25 5 - 25
Typical release time at U_N	[ms]	20	5 - 20 5 - 20
Input circuit AC			Yellow LED, Varistor
Input circuit DC			Yellow LED, Damping diode
Output data			
Contact type	3 N/O contacts		
Contact material	AgNi		
Max. switching voltage	440 V AC / 250 V DC		
Minimum switching voltage	10 V (At 24 mA)		
Limiting continuous current	10 A (see diagram)		
Maximum switch-on current AC	50 A (20 ms, N/O contact)		
Maximum switch-on current DC	50 A (20 ms, N/O contact)		
Minimum switching current	10 mA (at 24 V)		
Maximum interrupting rating, ohmic load	250 V AC	2500 VA	
	440 V AC	4000 VA	
Motor load according to UL 508			1/3 HP, 120 V AC (single-phase AC motor) 1/2 HP, 240 V AC (single-phase AC motor) 1/2 HP, 240 V AC (three-phase induction motor)
General data			
Test voltage (winding / contact)	2.5 kV _{rms} (50 Hz, 1 min.)		
Ambient temperature (operation), AC	-40 °C ... 40 °C		
Ambient temperature (operation), DC	-40 °C ... 60 °C		
Nominal operating mode	100% operating factor		
Mechanical service life, AC	Approx. 10 ⁷ cycles		
Mechanical service life, DC	Approx. 10 ⁷ cycles		
Standards/regulations	DIN EN 50178		
Degree of pollution/surge voltage category	2 / III		
Mounting position/mounting	any / In rows with zero spacing		
Connection data solid/stranded/AWG			
Input side	0.14 ... 6 mm ² / 0.14 ... 4 mm ² / 26 - 10		
Output side	0.14 ... 6 mm ² / 0.14 ... 4 mm ² / 26 - 10		
Dimensions	44 mm / 96 mm / 91 mm		
EMC note	Class A product, see page 605		

Ordering data

Description	Input voltage U_N	Type	Order No.	Pcs./Pkt.
Pre-assembled coupling relay modules with power contact relay and screw connection	① 24 V DC	RIF-4-RSC-LDP-24DC/3X1	2903284	5
	② 120 V AC	RIF-4-RSC-LV-120AC/3X1	2903283	5
	③ 230 V AC	RIF-4-RSC-LV-230AC/3X1	2903282	5

RIF-4-RSC.../3X1 (3-N/O)

Operating voltage range

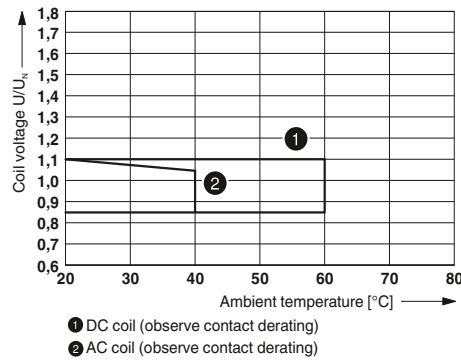

Interrupting rating

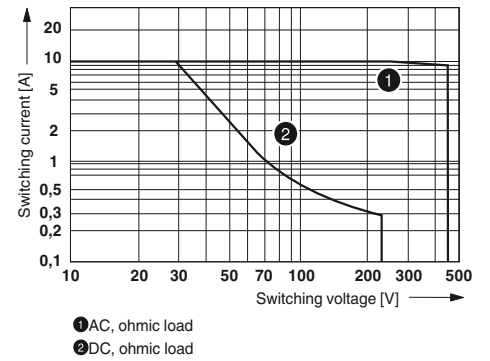

Contact derating

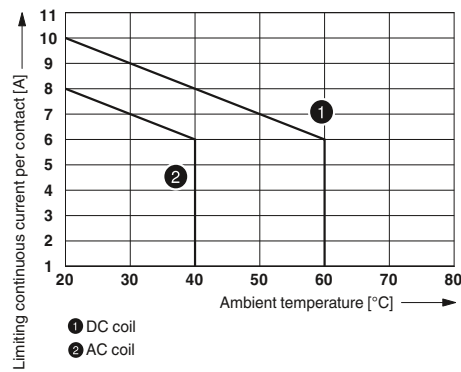

Electrical service life

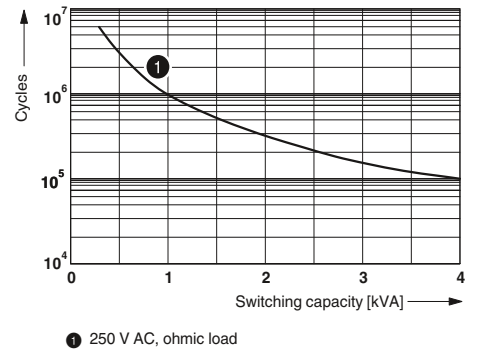

Relay modules

Industrial relay system - RIFLINE complete

RIFLINE complete accessories Plug-in bridges

The plug-in bridges can be used for simple potential distribution via all relay bases.

The end bracket is used for safe isolation between adjacent modules and to visually separate the various function groups.



Description	Color	Ordering data			Ordering data		
		Type	Order No.	Pcs./Pkt.	Type	Order No.	Pcs./Pkt.
Plug-in bridge							
2-pos. red, 32 A		FBS 2-6	3030336	50			
2-pos. blue, 32 A		FBS 2-6 BU	3036932	50			
2-pos. gray, 32 A		FBS 2-6 GY	3032237	50			
5-pos. red, 32 A		FBS 5-6	3030349	50			
10-pos. red, 32 A		FBS 10-6	3030271	10			
20-pos. red, 32 A		FBS 20-6	3030365	10			
50-pos. red, 32 A		FBS 50-6	3032224	10			
2-pos. red, 41 A		FBS 2-8	3030284	10			
2-pos. blue, 41 A		FBS 2-8 BU	3032567	10			
2-pos. gray, 41 A		FBS 2-8 GY	3032541	10			
End bracket , for snapping onto NS 35, 9.5 mm wide, can be marked with ZB 6, ZB 8/27, KLM...		7042			CLIPFIX 35	3022218	50

RIFLINE complete accessories Marking material

The ZB zack marker strip system offers numerous marking options that can be attached directly to the relay retaining brackets. In addition, further markings can be fixed to the relay base by means of double marker carriers.

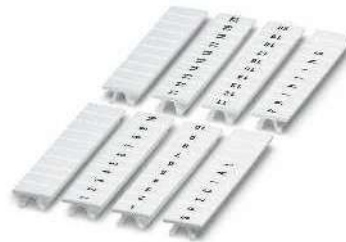

5.2 mm, 6.2 mm, and 15.2 mm wide



Double marker carrier

Description	Color	Ordering data			Ordering data		
		Type	Order No.	Pcs./Pkt.	Type	Order No.	Pcs./Pkt.
Zack marker strip, unprinted							
10-section	white	ZB 5 :UNBEDRUCKT	1050004	10			
10-section	white	ZB 6:UNBEDRUCKT	1051003	10			
5-section	white	ZB 15:UNBEDRUCKT	0811972	10			
Double marker carrier for ZB 5	gray				STP 5-2	0800967	100

RIFLINE complete accessories

Test plugs

The two-piece test plug offers individual plug color combinations. It is inserted directly in the function shaft of the Push-in connection.



		Ordering data		
Description	Color	Type	Order No.	Pcs./Pkt.
Test plug, consisting of:				
Metal part for 2.3 mm Ø socket hole and	silver	MPS-MT	0201744	10
Insulating sleeve , for MPS metal part	red	MPS-IH RD	0201676	10
	white	MPS-IH WH	0201663	10
	blue	MPS-IH BU	0201689	10
	yellow	MPS-IH YE	0201692	10
	green	MPS-IH GN	0201702	10
	gray	MPS-IH GY	0201728	10
	black	MPS-IH BK	0201731	10

Adapter for RIFLINE complete RF-1

RIF-1-V8... is the VARIOFACE adapter which connects the RIF-1 relay module with the VARIOFACE system cabling. This allows easy connection of eight relay modules to a controller.

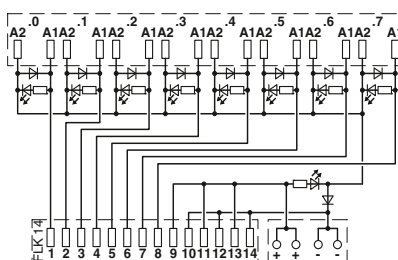

VARIOFACE adapter for RIFLINE complete RIF-1

		Technical data		
Maximum permissible operating voltage		30 V DC		
Maximum permissible current (per branch)		1 A (per signal path)		
Maximum total current (voltage supply)		3 A		
Rated surge voltage		0.6 kV (Functional insulation)		
Ambient temperature (operation)		-40 °C ... 60 °C		
Mounting position		any		
Standards/regulations		IEC 60664 , DIN EN 50178		
Connection method	Controller level	IDC/FLK pin strip		
	Supply	Push-in connection		
Connection data solid/stranded/AWG		0.2 ... 1.5 mm ² / 0.2 ... 1.5 mm ² / 24 - 16		
Dimensions	H / D	101 mm / 75 mm		

		Ordering data			
Description	No. of pos.	Module width W	Type	Order No.	Pcs./Pkt.
V8 adapter , for eight RIF-1 relay modules, with IDC/FLK pin strip for PLC system cabling, positive switching					
	14	128 mm	RIF-1-V8/PT/FLK14/OUT	2905195	1

Relay modules

Highly compact relay modules - PLC-INTERFACE

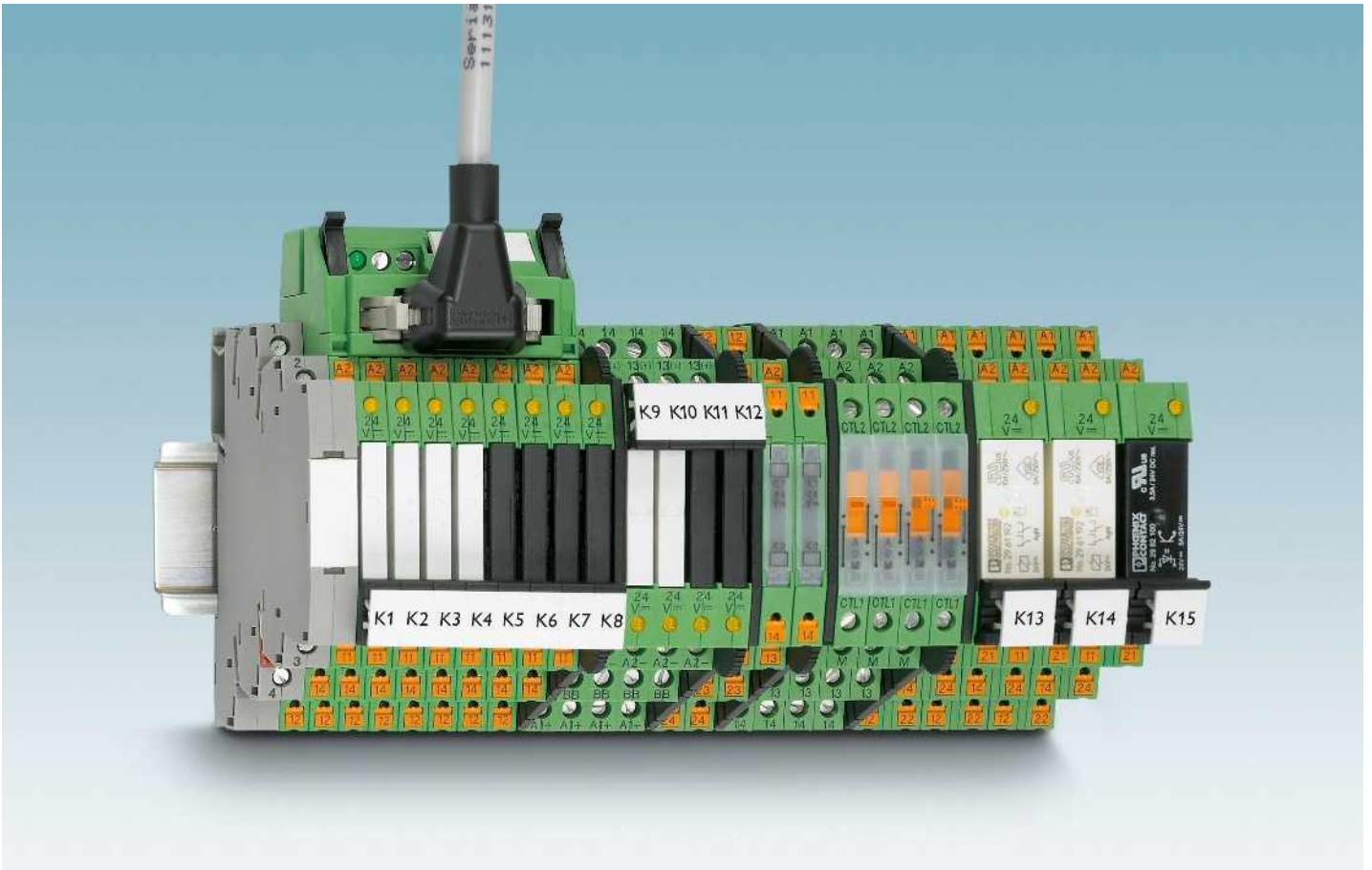

The PLC-INTERFACE relay system is the interface between the controller and system I/O devices.

The universal design is compact and space-saving. While the narrow 6.2 mm module has one contact, the 14 mm version is available with two contacts. The modules can be equipped with either an electromechanical or a solid-state relay.

They are protected against environmental influences by RTIII (IP67). The relays also offer safe isolation according to DIN EN 50178 (VDE 0160).

PLC-INTERFACE is available in three connection technologies. Depending on the area of application, screw or Push-in connection can be selected.

In addition to the universal types, PLC-INTERFACE is also available in numerous special versions. These include:

- Sensor and actuator modules that can accommodate all connections directly on the interface
- Modules for high inrush or continuous currents
- Railway modules, which meet specific railway requirements
- Filter modules, which filter out interference on the input side

Plug-in bridges are available for all modules for simple potential distribution. In addition, solutions from system cabling applications offer easy connection to the plant control system. VARIOFACE adapters can be used to reduce wiring effort considerably. Installation is simplified significantly thanks to the integrated input and protective circuit.

Standard marking material for CLIPLINE complete terminal blocks can be used to mark PLC-INTERFACE.



Universal modules

PLC-R... and PLC-O... relay and solid-state relay modules with PDT or N/O contact, designed for universal use. Available in an overall width of 6.2 mm with one contact or in 14 mm with two contacts.

Available with either screw or Push-in connection.



Sensors/actuators

PLC...SEN and PLC...ACT offer space-saving sensor and actuator wiring without additional supply or output terminal blocks. The sensor or actuator connections are incorporated directly at the relay module.

Available with either screw or Push-in connection.



High currents

PLC...IC is particularly suitable for applications with high inrush currents, e.g. from lamp loads. The PLC...HC relay modules are designed for applications with high continuous currents.

Available with either screw or Push-in connection.



Railway applications

PLC...RW relay or solid-state relay modules are suitable for railway requirements. These cover, for example, the extended temperature and input voltage range of railway applications.

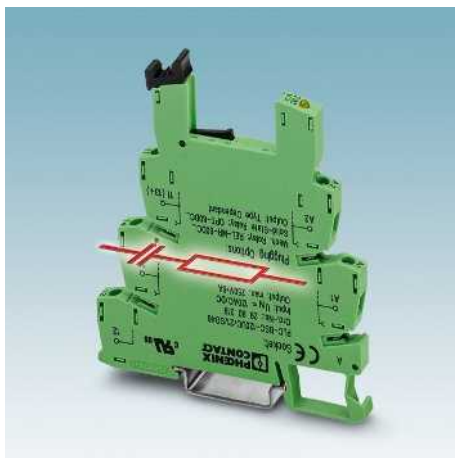

Interference signals on the input side

PLC-B...SO46 basic terminal blocks are used for filtering interference currents and interference voltages on the input side.

Available with either screw or Push-in connection.



Accessories

The entire PLC-INTERFACE system can be extended by a range of accessories such as power terminals, adapters for system cabling or plug-in bridges for potential distribution.

Relay modules

Highly compact relay modules - PLC-INTERFACE

Product overview

Highly compact relay modules - special versions and accessories

		Page	Web code
 Actuator series	PLC-R.../1/ACT Assembled with a plug-in power contact relay	378	#0618
	PLC-R.../11C/ACT Assembled with a plug-in miniature relay for high inrush currents	386	
	PLC-O.../24DC/2/ACT Assembled with a plug-in solid-state power relay	380	
	PLC-OSC.../230AC/1/ACT Assembled with a plug-in solid-state power relay	381	
 Sensor series	PLC-R.../1AU/SEN Assembled with a plug-in relay for small switching capacities, with gold-plated multi-layer contact	384	#0617
	PLC-O.../48DC/100/SEN Assembled with a plug-in solid-state input relay	385	
 Filter series	PLC-B...UC/21/SO46 For assembly with electromechanical or solid-state relays	388	#0689
	PLC-B...UC/1/SEN/SO46 For assembly with electromechanical or solid-state relays	389	
	PLC-BSC...UC/21-21/SO46 For assembly with relays	389	
	PLC-BSC...UC/21/HC/SO46 For assembly with relays	389	
 Switch modules	PLC-RS...-24UC/1/S... Relay and switch integrated	404	#0898
	PLC-S...-S/... Switch integrated	405	
 Solid-state relays	PLC-O.../24DC/... Optocoupler modules for universal use	376	#0899
	PLC-O.../230AC/... Switching capacity up to 230 V AC and 2.4 A in 6.2 mm	408	
	PLC-O.../300DC/... DC voltage output up to 300 V DC	406	
 Ex relays	PLC-R.../21/EX 1 changeover contact with power contact	458	#0690
	PLC-R.../21-21/EX 2 changeover contacts with power contact	458	
	PLC-R.../21/HC/EX 1 changeover contact up to 10 A	459	
	PLC-O...C1D2 DC voltage output	459	

Highly compact relay modules - PLC-INTERFACE

Hybrid solid-state relays	PLC-INTERFACE for railway applications	PLC-INTERFACE for high inrush currents	Reversing load relays
<p>PLC-H...24DC/230AC/10 Hybrid solid-state relay with AC voltage output, max. 10 A</p>	<p>PLC.../RW Relay modules with extended input voltage and temperature range, specifically designed for use in railway applications</p>	<p>PLC...11C/ACT Max. switch-on current of 130 A, suitable for capacitive loads, available with screw and Push-in connection technology</p>	<p>PLC-S...-ELR W 1/2-24DC Electronic reversing load relay for motors up to 24 V DC/2 A</p>
<p>Page: 409 Web code: #0691</p>	<p>Page: 415 Web code: #0900</p>	<p>Page: 386 Web code: #0901</p>	<p>Page: 421 Web code: #0693</p>

Accessories			Web code: #0692 Page: 424
	<p>Continuous plug-in bridge 500 mm long, insulated, can be cut to length, for potential distribution with PLC-INTERFACE</p>	<p>Plug-in bridge 2-pos., 6 mm long, bridges potentials of neighboring PLC-INTERFACES</p>	<p>Plug-in bridge 2-pos., 8 mm long, bridges potentials of neighboring PLC-INTERFACES with partition plate</p>
	<p>Plug-in bridge 2-pos., for connecting adjacent connections on a 14 mm PLC-INTERFACE</p>	<p>Partition plate 2 mm thick, required at the start and end of every PLC terminal strip</p>	<p>Passive feed-through bridge Can be inserted instead of a relay or solid-state relay, bridges terminal points A1 and 14</p>

Logic modules			Web code: #0694 Page: 428
	<p>PLC-V8C.../SAM Stand-alone module With 16 I/Os, cannot be extended, connection to PC via micro USB socket. Integrated real-time clock, accommodates external IFS-CONFSTICK memory module.</p>	<p>PLC-V8C.../BM Basic module With 16 I/Os, can be extended up to a maximum of 48 I/Os. Connection to PC via micro USB socket. Integrated real-time clock. Accommodates external IFS-CONFSTICK memory module. Optional connection to IFS gateways.</p>	<p>PLC-V8C.../EM Extension module With 16 I/Os, for extending the basic module. A maximum of two extension modules can be connected to each basic module.</p>

System cabling adapters for PLC-INTERFACE			Web code: #0897 Page: 425
	<p>PLC-V8/FLK14... For 6.2 mm relay, with 14-pos. IDC/FLK pin strip, module width 49.6 mm</p>	<p>PLC-V8/D15S/... For 6.2 mm relay, with 15-pos. D-SUB socket strip, module width 49.6 mm</p>	<p>PLC-V8L/FLK14/... For 14 mm relay, with 14-pos. IDC/FLK pin strip, module width 112.3 mm</p>

Relay modules

Highly compact relay modules - PLC-INTERFACE

Universal PLC series with PDT relay

PLC-R... is the relay series that can be used universally and consists of basic terminal blocks and plug-in relays with PDT contacts.

The advantages:

- Slim design
- Screw and Push-in connection technology
- Functional plug-in bridges
- Integrated input and interference suppression circuit
- High degree of protection, RT III (wash-proof), or RT II for 1-PDT relay with manual operation
- Safe isolation according to DIN EN 50178 between coil and contact
- Efficient connection to system cabling using V8 adapter

Notes:
Type of insulating housing: Polyamide PBT, non-reinforced, color: green.
Marking systems and mounting material See Catalog 3
The PLC-ATP partition plate must be installed for voltages larger than 250 V (L1, L2, L3) between identical terminal blocks in adjacent modules. Potential bridging is then carried out with FBST 8-PLC... or FBST 500....
If the specified maximum values for multi-layer contact relays are exceeded, the gold plating is destroyed. The maximum values of the power contact relay are then valid. This can result in a shorter service life than with a pure power contact.
For diagrams of operating voltage ranges, see page 397
Note: for marking material (ZB 6), see "CLIPLINE industrial connection technology, marking material for terminals, conductors, and cables".
Inflammability class V0 (UL 94)
1) 120 and 230 V types up to 55 °C



1-PDT relay module, 6 A, maximum

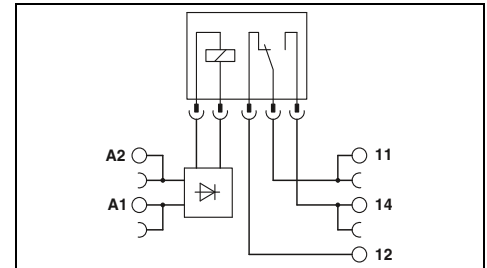

Input data	
Typical input current at U_N	[mA]
Response/release time at U_N	[ms]
Input circuit DC	
Input circuit AC/DC	
Output data	
Contact material	AgSnO
Max. switching voltage	250 V AC/DC
Minimum switching voltage	5 V (at 100 mA)
Limiting continuous current	6 A
Maximum switch-on current	10 A (4 s)
Minimum switching current	10 mA (at 12 V)
General data	
Test voltage input/output	4 kV AC (50 Hz, 1 min.)
Ambient temperature (operation)	-40 °C ... 60 °C ¹⁾
Mechanical service life	2 x 10 ⁷ cycles
Standards/regulations	IEC 60664, EN 50178
Connection data solid/stranded/AWG	0.14 - 2.5 mm ² / 0.14 - 2.5 mm ² / 26 - 14
Dimensions	W / H / D
EMC note	Class A product, see page 605

Technical data						
①	②	③	④	⑤	⑥	⑦
15.3	9	11	9.2	4.8	3.5	3.2
5/8	5/8	6/15	5/8	5/8	6/15	7/15
Yellow LED, reverse polarity protection, freewheeling diode						
Yellow LED, bridge rectifier						

Ordering data

Description	Input voltage U_N	Type	Order No.	Pcs./Pkt.
PLC-INTERFACE, with screw connection				
①	12 V DC	PLC-RSC- 12DC/21	2966906	10
②	24 V DC	PLC-RSC- 24DC/21	2966171	10
③	24 V AC/DC	PLC-RSC- 24UC/21	2966184	10
④	48 V DC	PLC-RSC- 48DC/21	2966113	10
⑤	60 V DC	PLC-RSC- 60DC/21	2966139	10
⑥	120 V AC / 110 V DC	PLC-RSC-120UC/21	2966197	10
⑦	230 V AC / 220 V DC	PLC-RSC-230UC/21	2966207	10
PLC-INTERFACE, with Push-in connection				
①	12 V DC	PLC-RPT- 12DC/21	2900316	10
②	24 V DC	PLC-RPT- 24DC/21	2900299	10
③	24 V AC/DC	PLC-RPT- 24UC/21	2900300	10
④	48 V DC	PLC-RPT- 48DC/21	2900301	10
⑤	60 V DC	PLC-RPT- 60DC/21	2900303	10
⑥	120 V AC / 110 V DC	PLC-RPT-120UC/21	2900304	10
⑦	230 V AC / 220 V DC	PLC-RPT-230UC/21	2900305	10

Electrical interrupting rating for PLC...21 with 1-PDT relay

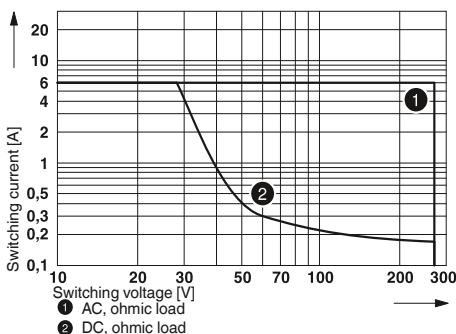

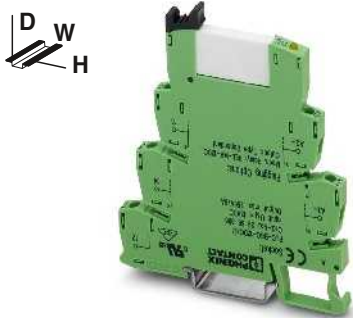

1-PDT relay module, 50 mA, maximum

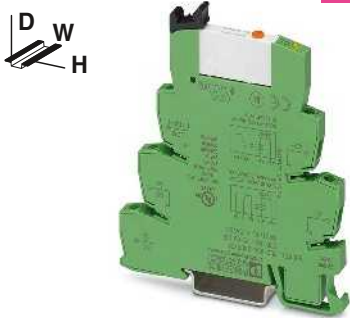

1-PDT relay module with manual operation, max. 6 A

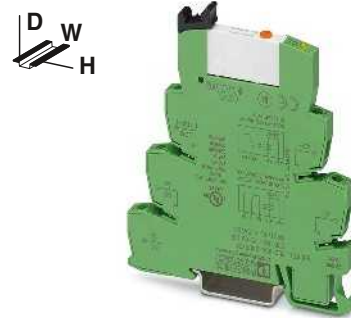

1-PDT relay module with manual operation, max. 50 mA

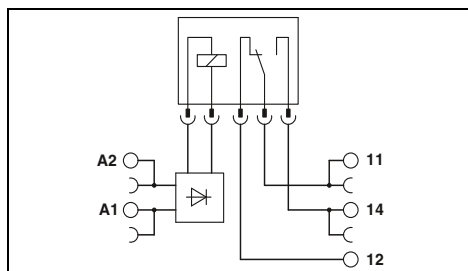
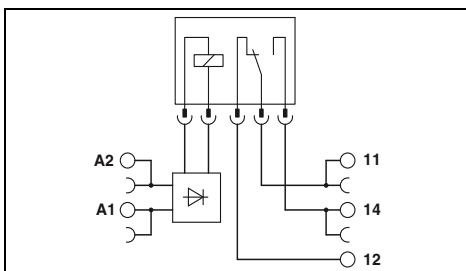
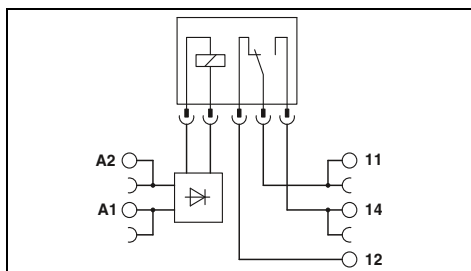

Technical data						
①	②	③	④	⑤	⑥	⑦
15.3	9	11	9.2	4.8	3.5	3.2
5/8	5/8	6/15	5/8	5/8	6/15	7/15
Yellow LED, reverse polarity protection, freewheeling diode						
Yellow LED, bridge rectifier						
AgSnO, hard gold-plated						
30 V AC / 36 V DC						
100 mV (at 10 mA)						
50 mA						
50 mA						
1 mA (at 24 V)						
4 kV AC (50 Hz, 1 min.)						
-40 °C ... 60 °C ¹⁾						
2 x 10 ⁷ cycles						
IEC 60664 , EN 50178						
0.14 - 2.5 mm ² / 0.14 - 2.5 mm ² / 26 - 14						
6.2 mm / 80 mm / 94 mm						
Class A product, see page 605						

Technical data						
①	②	③	⑥	⑦		
15.3	9	11	3.5	3.2		
5/8	5/8	6/15	6/15	7/15		
Yellow LED						
Yellow LED, bridge rectifier						
AgSnO						
250 V AC/DC						
5 V (at 100 mA)						
6 A						
10 A (4 s)						
10 mA (at 12 V)						
4 kV AC (50 Hz, 1 min.)						
-40 °C ... 60 °C						
1 x 10 ⁷ cycles						
IEC 60664 , EN 50178						
0.14 - 2.5 mm ² / 0.14 - 2.5 mm ² / 26 - 14						
6.2 mm / 80 mm / 94 mm						
Class A product, see page 605						

Technical data						
①	②	③	⑥	⑦		
15.3	9	11	3.5	3.2		
5/8	5/8	6/15	6/15	7/15		
Yellow LED, reverse polarity protection, freewheeling diode						
Yellow LED, bridge rectifier						
AgSnO, hard gold-plated						
30 V AC / 36 V DC						
100 mV (at 10 mA)						
50 mA						
50 mA						
1 mA (at 24 V)						
4 kV AC (50 Hz, 1 min.)						
-40 °C ... 60 °C						
2 x 10 ⁷ cycles						
IEC 60664 , EN 50178						
0.14 - 2.5 mm ² / 0.14 - 2.5 mm ² / 26 - 14						
6.2 mm / 80 mm / 94 mm						
Class A product, see page 605						

Ordering data		
Type	Order No.	Pcs./ Pkt.
PLC-RSC- 12DC/21AU	2966919	10
PLC-RSC- 24DC/21AU	2966265	10
PLC-RSC- 24UC/21AU	2966278	10
PLC-RSC- 48DC/21AU	2966126	10
PLC-RSC- 60DC/21AU	2966142	10
PLC-RSC-120UC/21AU	2966281	10
PLC-RSC-230UC/21AU	2966294	10
PLC-RPT- 12DC/21AU	2900317	10
PLC-RPT- 24DC/21AU	2900306	10
PLC-RPT- 24UC/21AU	2900307	10
PLC-RPT- 48DC/21AU	2900308	10
PLC-RPT- 60DC/21AU	2900309	10
PLC-RPT-120UC/21AU	2900310	10
PLC-RPT-230UC/21AU	2900311	10

Ordering data		
Type	Order No.	Pcs./ Pkt.
PLC-RSC- 12DC/21/MS	2909648	10
PLC-RSC- 24DC/21/MS	2909649	10
PLC-RSC- 24UC/21/MS	2909650	10
PLC-RSC-120UC/21/MS	2909651	10
PLC-RSC-230UC/21/MS	2909653	10
PLC-RPT- 12DC/21/MS	2909666	10
PLC-RPT- 24DC/21/MS	2909667	10
PLC-RPT- 24UC/21/MS	2909668	10
PLC-RPT-120UC/21/MS	2909669	10
PLC-RPT-230UC/21/MS	2909670	10

Ordering data		
Type	Order No.	Pcs./ Pkt.
PLC-RSC- 12DC/21AU/MS	2909654	10
PLC-RSC- 24DC/21AU/MS	2909655	10
PLC-RSC- 24UC/21AU/MS	2909656	10
PLC-RSC-120UC/21AU/MS	2909657	10
PLC-RSC-230UC/21AU/MS	2909660	10
PLC-RPT- 12DC/21AU/MS	2909671	10
PLC-RPT- 24DC/21AU/MS	2909672	10
PLC-RPT- 24UC/21AU/MS	2909673	10
PLC-RPT-120UC/21AU/MS	2909674	10
PLC-RPT-230UC/21AU/MS	2909676	10

Relay modules

Highly compact relay modules - PLC-INTERFACE

Universal PLC series with PDT relay

PLC-R... is the relay series that can be used universally and consists of basic terminal blocks and plug-in relays with PDT contacts.

The advantages:

- Slim design
- Screw and Push-in connection technology
- Functional plug-in bridges
- Integrated input and interference suppression circuit
- RT III sealed relay
- Safe isolation according to DIN EN 50178 between coil and contact
- Efficient connection to system cabling using V8 adapter

Notes:
Type of insulating housing: Polyamide PBT, non-reinforced, color: green.
Marking systems and mounting material See Catalog 3
The PLC-ATP partition plate must be installed for voltages larger than 250 V (L1, L2, L3) between identical terminal blocks in adjacent modules. Potential bridging is then carried out with FBST 8-PLC... or FBST 500....
For diagrams of operating voltage ranges, see page 397
Note: for marking material (ZB 6), see "CLIPLINE industrial connection technology, marking material for terminals, conductors, and cables".
Inflammability class V0 (UL 94)
1) 230 V types up to 55 °C
2) If the specified maximum values are exceeded for multi-layer contact relays, the gold layer will be destroyed. During further use, the maximum values of the power contact relays apply. This may then result in a shorter service life than a dedicated power contact.



2-PDT relay module,
2 x 6 A, maximum

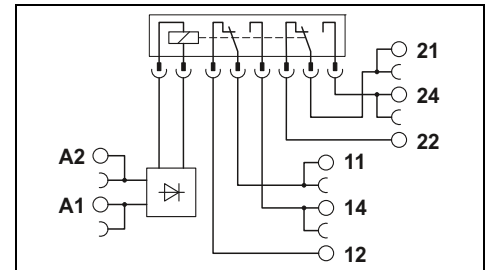

Input data	
Typical input current at U_N	[mA]
Response/release time at U_N	[ms]
Input circuit DC	
Input circuit AC/DC	
Output data	
Contact material	AgNi
Max. switching voltage	250 V AC/DC
Minimum switching voltage	5 V AC/DC (at 10 mA)
Limiting continuous current	6 A
Maximum switch-on current	15 A (300 ms)
Minimum switching current	10 mA (At 5 V)
General data	
Test voltage input/output	4 kV AC (50 Hz, 1 min.)
Ambient temperature (operation)	-40 °C ... 60 °C ¹⁾
Mechanical service life	3 x 10 ⁷ cycles
Standards/regulations	IEC 60664, EN 50178
Connection data solid/stranded/AWG	0.14 - 2.5 mm ² / 0.14 - 2.5 mm ² / 26 - 14
Dimensions	W / H / D
EMC note	Class A product, see page 605

Technical data						
①	②	③	④	⑤	⑥	⑦
33	18	17.5	20	10	4.5	4.5
8 / 10	8 / 10	8 / 10	8 / 10	8 / 10	7 / 10	7 / 10
Yellow LED, reverse polarity protection, freewheeling diode						
Yellow LED, bridge rectifier						

Ordering data	
Type	Order No.
PLC-RSC- 12DC/21-21	2967235
PLC-RSC- 24DC/21-21	2967060
PLC-RSC- 24UC/21-21	2967073
PLC-RSC- 48DC/21-21	2967248
PLC-RSC- 60DC/21-21	2967293
PLC-RSC-120UC/21-21	2967086
PLC-RSC-230UC/21-21	2967099

Description	Input voltage U_N
PLC-INTERFACE, with screw connection	
①	12 V DC
②	24 V DC
③	24 V AC/DC
④	48 V DC
⑤	60 V DC
⑥	120 V AC / 110 V DC
⑦	230 V AC / 220 V DC
PLC-INTERFACE, with Push-in connection	
①	12 V DC
②	24 V DC
③	24 V AC/DC
④	48 V DC
⑤	60 V DC
⑥	120 V AC / 110 V DC
⑦	230 V AC / 220 V DC

Type	Order No.	Pcs./ Pkt.
PLC-RPT- 12DC/21-21	2900329	10
PLC-RPT- 24DC/21-21	2900330	10
PLC-RPT- 24UC/21-21	2900332	10
PLC-RPT- 48DC/21-21	2900333	10
PLC-RPT- 60DC/21-21	2900334	10
PLC-RPT-120UC/21-21	2900335	10
PLC-RPT-230UC/21-21	2900336	10

Electrical interrupting rating for PLC...21-21 with 2-PDT relay

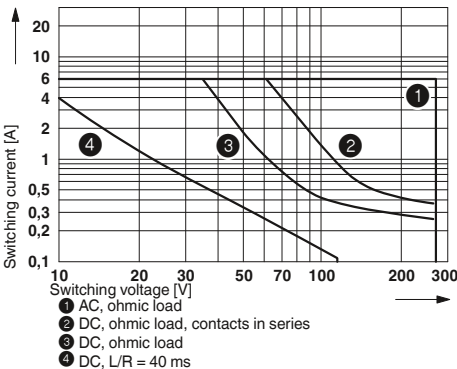



2-PDT relay module,
2 x 50 mA, maximum

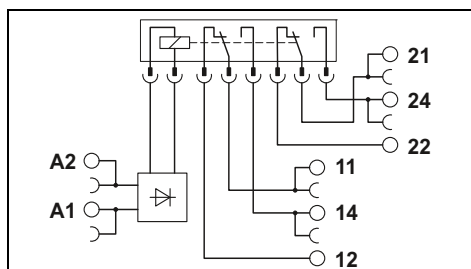

Technical data

①	②	③	④	⑤	⑥	⑦
33	18	17.5	20	10	4.5	4.5
8/10	8/10	8/10	8/10	8/10	7/10	7/10
Yellow LED, reverse polarity protection, freewheeling diode						
Yellow LED, bridge rectifier						

AgNi, hard gold-plated
30 V AC / 36 V DC
100 mV (at 10 mA)
50 mA²
50 mA²
1 mA (at 24 V)

4 kV AC (50 Hz, 1 min.)
-40 °C ... 60 °C¹
3 x 10⁷ cycles
IEC 60664, EN 50178
0.14 - 2.5 mm² / 0.14 - 2.5 mm² / 26 - 14
14 mm / 80 mm / 94 mm
Class A product, see page 605

Ordering data

Type	Order No.	Pcs./Pkt.
PLC-RSC- 12DC/21-21AU	2967277	10
PLC-RSC- 24DC/21-21AU	2967125	10
PLC-RSC- 24UC/21-21AU	2967112	10
PLC-RSC- 48DC/21-21AU	2967280	10
PLC-RSC- 60DC/21-21AU	2967303	10
PLC-RSC-120UC/21-21AU	2967138	10
PLC-RSC-230UC/21-21AU	2967141	10
PLC-RPT- 12DC/21-21AU	2900337	10
PLC-RPT- 24DC/21-21AU	2900338	10
PLC-RPT- 24UC/21-21AU	2900339	10
PLC-RPT- 48DC/21-21AU	2900340	10
PLC-RPT- 60DC/21-21AU	2900341	10
PLC-RPT-120UC/21-21AU	2900342	10
PLC-RPT-230UC/21-21AU	2900343	10

Relay modules

Highly compact relay modules - PLC-INTERFACE

Universal PLC series with solid-state relays

PLC-O... is the solid-state relay series that can be used universally comprising basic terminal blocks and plug-in solid-state relays.

The advantages:

- Slim design
- Screw and Push-in connection technology
- Functional plug-in bridges
- Integrated input circuit
- RT-III sealed solid-state relays
- High switching capacity
- Zero voltage switch at AC output
- Efficient connection to system cabling using V8 adapter

Notes:
Type of insulating housing: Polyamide PBT, non-reinforced, color: green.
Marking systems and mounting material See Catalog 3
The PLC-ATP partition plate must be installed for voltages larger than 250 V (L1, L2, L3) between identical terminal blocks in adjacent modules. Potential bridging is then carried out with FBST 8-PLC... or FBST 500....
For derating curves see page 399



Solid-state relay module, DC output max. 100 mA

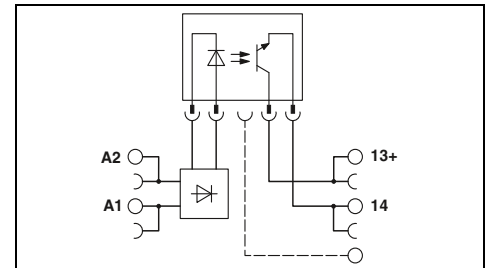

Input data	
Permissible range (with reference to U_N)	
Switching level (with reference to U_N)	1 signal ("H") 0 signal ("L")
Typical input current at U_N	[mA]
Typical switch-on time at U_N	[ms]
Typical switch-off time at U_N	[ms]
Transmission frequency f_{limit}	[Hz]
Input circuit DC	
Input circuit AC/DC	
Output data	
Max. switching voltage	48 V DC
Minimum switching voltage	3 V DC
Maximum switch-on current	-
Minimum/maximum switching current	- / 100 mA
Output protection	Reverse polarity protection, surge protection
Voltage drop at maximum limiting continuous current	≤ 1 V
Leakage current in off state	-
Max. load value	-
General data	
Test voltage input/output	2.5 kV (50 Hz, 1 min.)
Ambient temperature (operation)	-25 °C ... 60 °C
Standards/regulations	IEC 60664 , EN 50178
Degree of pollution/surge voltage category	2 / III
Connection data solid/stranded/AWG	0.14 - 2.5 mm ² / 0.14 - 2.5 mm ² / 26 - 14
Dimensions	W / H / D
EMC note	Class A product, see page 605

Technical data

①	②	③	④	⑤	⑥
0.8 - 1.2	0.8 - 1.2	0.8 - 1.2	0.8 - 1.1	0.9 - 1.1	0.9 - 1.1
≥ 0.8	≥ 0.8	≥ 0.8	≥ 0.8	≥ 0.9	≥ 0.8
≤ 0.4	≤ 0.3	≤ 0.4	≤ 0.4	≤ 0.3	≤ 0.3
8.5	9	5	3	3.5	3.5
0.02	0.03	0.04	1	3	3
0.3	0.3	2	3	4	5
300	300	100	50	10	10

Yellow LED, reverse polarity protection , freewheeling diode
Yellow LED, bridge rectifier

Ordering data

Description	Input voltage U_N	Type	Order No.	Pcs./ Pkt.
PLC-INTERFACE, with screw connection				
①	24 V DC	PLC-OSC- 24DC/ 48DC/100	2966728	10
②	48 V DC	PLC-OSC- 48DC/ 48DC/100	2966993	10
③	60 V DC	PLC-OSC- 60DC/ 48DC/100	2967455	10
④	125 V DC	PLC-OSC-125DC/ 48DC/100	2980047	10
⑤	120 V AC / 110 V DC	PLC-OSC-120UC/ 48DC/100	2966744	10
⑥	230 V AC / 220 V DC	PLC-OSC-230UC/ 48DC/100	2966757	10
PLC-INTERFACE, with Push-in connection				
①	24 V DC	PLC-OPT- 24DC/ 48DC/100	2900352	10
②	48 V DC	PLC-OPT- 48DC/ 48DC/100	2900353	10
③	60 V DC	PLC-OPT- 60DC/ 48DC/100	2900354	10
⑤	120 V AC / 110 V DC	PLC-OPT-120UC/ 48DC/100	2900355	10
⑥	230 V AC / 220 V DC	PLC-OPT-230UC/ 48DC/100	2900356	10

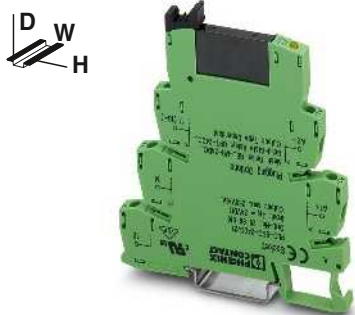

Solid-state relay module,
DC output max. 3 A

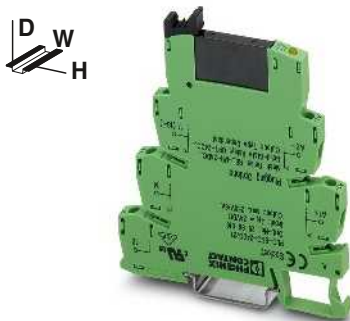

Solid-state relay module,
AC output max. 750 mA

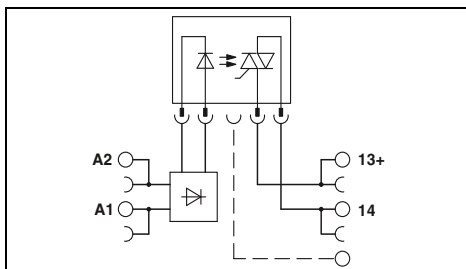
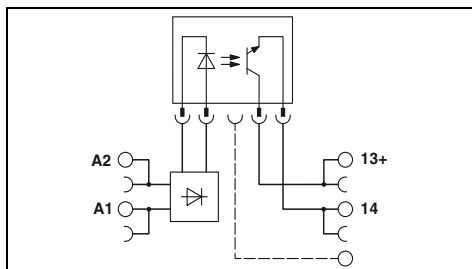

Technical data

①	②	③	④	⑤	⑥
0.8 - 1.2	0.8 - 1.2	0.8 - 1.2	0.8 - 1.1	0.9 - 1.1	0.9 - 1.1
≥ 0.8	≥ 0.8	≥ 0.8	≥ 0.8	≥ 0.8	≥ 0.8
≤ 0.4	≤ 0.4	≤ 0.3	≤ 0.3	≤ 0.3	≤ 0.3
8.5	9	5	3	3.5	3.5
0.02	0.03	0.04	0.04	3.5	4
0.3	0.3	0.5	0.6	7	7
300	300	100	100	10	10

Yellow LED, reverse polarity protection, freewheeling diode
Yellow LED, bridge rectifier

33 V DC
3 V DC
15 A (10 ms)
- / 3 A (see derating curve)
Reverse polarity protection, surge protection
≤ 200 mV

-
-
2.5 kV (50 Hz, 1 min.)
-25 °C ... 60 °C
IEC 60664, EN 50178
2 / III

0.14 - 2.5 mm² / 0.14 - 2.5 mm² / 26 - 14
6.2 mm / 80 mm / 94 mm
Class A product, see page 605

Technical data

①	②	③	④	⑤	⑥
0.8 - 1.2	0.8 - 1.2	0.8 - 1.2	0.8 - 1.1	0.9 - 1.1	0.8 - 1.1
≥ 0.8	≥ 0.8	≥ 0.8	≥ 0.8	≥ 0.8	≥ 0.8
≤ 0.25	≤ 0.25	≤ 0.3	≤ 0.3	≤ 0.25	≤ 0.25
8	9	6	3.5	4	3.5
10	10	10	10	10	10
10	10	10	10	10	10
10	10	10	10	3	3

253 V AC
24 V AC
30 A (10 ms)
10 mA / 0.75 A (see derating curve)
RCV circuit
< 1 V

< 1 mA (in off state)
4.5 A²s
2.5 kV (50 Hz, 1 min.)
-25 °C ... 60 °C
IEC 60664, EN 50178
2 / III

0.14 - 2.5 mm² / 0.14 - 2.5 mm² / 26 - 14
6.2 mm / 80 mm / 94 mm
Class A product, see page 605

Ordering data

Type	Order No.	Pcs./ Pkt.
PLC-OSC- 24DC/ 24DC/ 2	2966634	10
PLC-OSC- 48DC/ 24DC/ 2	2967002	10
PLC-OSC- 60DC/ 24DC/ 2	2967468	10
PLC-OSC-125DC/ 24DC/ 2	2980050	10
PLC-OSC-120UC/ 24DC/ 2	2966650	10
PLC-OSC-230UC/ 24DC/ 2	2966663	10
PLC-OPT- 24DC/ 24DC/2	2900364	10
PLC-OPT- 48DC/ 24DC/2	2900365	10
PLC-OPT- 60DC/ 24DC/2	2900366	10
PLC-OPT-120UC/ 24DC/2	2900367	10
PLC-OPT-230UC/ 24DC/2	2900368	10

Ordering data

Type	Order No.	Pcs./ Pkt.
PLC-OSC- 24DC/230AC/ 1	2967840	10
PLC-OSC- 48DC/230AC/ 1	2967853	10
PLC-OSC- 60DC/230AC/ 1	2967866	10
PLC-OSC-125DC/230AC/ 1	2980063	10
PLC-OSC-120UC/230AC/ 1	2967879	10
PLC-OSC-230UC/230AC/ 1	2967882	10
PLC-OPT- 24DC/230AC/1	2900369	10
PLC-OPT- 48DC/230AC/1	2900370	10
PLC-OPT- 60DC/230AC/1	2900371	10
PLC-OPT-120UC/230AC/1	2900372	10
PLC-OPT-230UC/230AC/1	2900374	10

Relay modules

Highly compact relay modules - PLC-INTERFACE

PLC actuator series for output functions

The PLC actuator series couples controllers and actuators such as motors, contactors, and valves.

The advantages:

- Direct connection of actuator to relay module including load return line
- No need for additional terminal blocks
- Space savings of up to 80%
- Time savings of up to 60%
- Screw and Push-in connection technology
- Relay modules with safe isolation according to DIN EN 50178 between coil and contact
- Functional plug-in bridges
- Efficient connection to system cabling using V8 adapter

Notes:
Type of insulating housing: Polyamide PBT, non-reinforced, color: green.
Marking systems and mounting material See Catalog 3
The PLC-ATP partition plate must be installed for voltages larger than 250 V (L1, L2, L3) between identical terminal blocks in adjacent modules. Potential bridging is then carried out with FBST 8-PLC... or FBST 500....
For diagrams of operating voltage ranges, see page 397
For derating curves see page 399



1-N/O relay module with additional floating terminal point

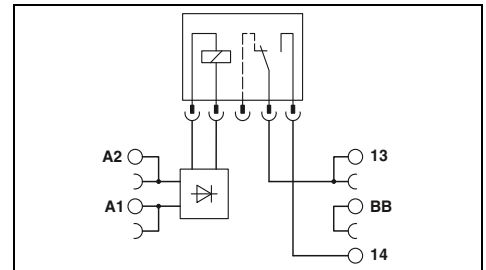

Electrical interrupting rating for PLC...24DC/1/ACT with 1-N/O relay

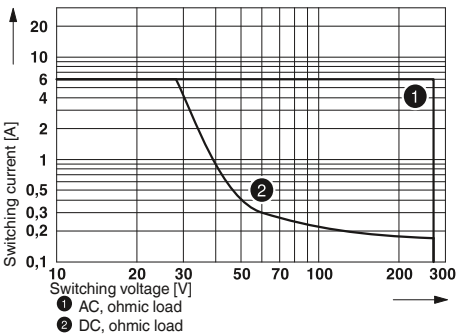

Electrical interrupting rating for PLC...24DC/1-1/ACT with 2-N/O relay

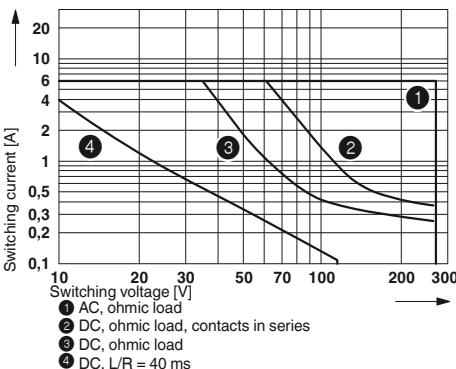

Input data	
Permissible range (with reference to U_N)	
Typical input current at U_N	[mA]
Typical response time/switch-on time at U_N	[ms]
Typical release time/switch-off time at U_N	[ms]
Input circuit DC	
Output data	
Contact material	
Max. switching voltage	
Minimum switching voltage	
Limiting continuous current	
Maximum switch-on current	
Minimum switching current	
General data	
Test voltage input/output	
Ambient temperature (operation)	
Mechanical service life	
Standards/regulations	
Degree of pollution/surge voltage category	
Connection data solid/stranded/AWG	
Dimensions	W / H / D
EMC note	

Technical data	
①	See diagram
	9
	5
	8
	Yellow LED, reverse polarity protection, freewheeling diode
	AgSnO
	250 V AC/DC
	5 V (at 100 mA)
	6 A
	10 A (4 s)
	10 mA (at 12 V)
	4 kV AC (50 Hz, 1 min.)
	-40 °C ... 60 °C
	2 x 10 ⁷ cycles
	IEC 60664 , EN 50178
	3 / III
	0.14 - 2.5 mm ² / 0.14 - 2.5 mm ² / 26 - 14
	6.2 mm / 80 mm / 94 mm
	Class A product, see page 605

Description	Input voltage U_N
PLC-INTERFACE, with screw connection	
①	24 V DC
PLC-INTERFACE, with Push-in connection	
①	24 V DC

Ordering data		
Type	Order No.	Pcs./ Pkt.
PLC-RSC- 24DC/ 1/ACT	2966210	10
PLC-RPT- 24DC/ 1/ACT	2900312	10

new



1-N/O relay module with manual operation and additional floating terminal point



2-N/O relay module with additional floating terminal points

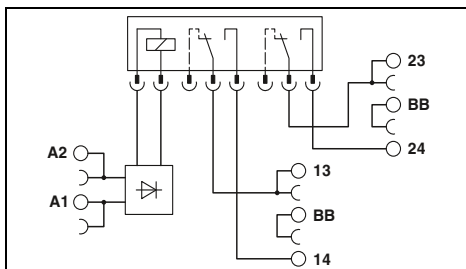
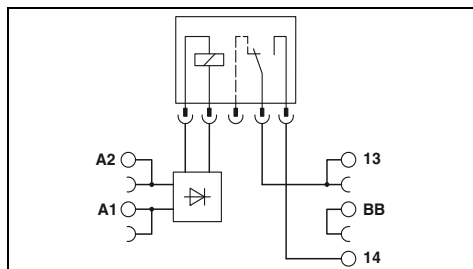

Technical data

①
See diagram
9
5
8
Yellow LED, reverse polarity protection, freewheeling diode

AgSnO
250 V AC/DC
5 V (at 100 mA)
6 A
10 A (4 s)
10 mA (at 12 V)

4 kV AC (50 Hz, 1 min.)
-40 °C ... 60 °C
1 x 10⁷ cycles
IEC 60664 , EN 50178
3 / III

0.14 - 2.5 mm² / 0.14 - 2.5 mm² / 26 - 14
6.2 mm / 80 mm / 94 mm
Class A product, see page 605

Ordering data

Type	Order No.	Pcs./ Pkt.
PLC-RSC- 24DC/ 1/MS/ACT	2909661	10
PLC-RPT- 24DC/ 1/MS/ACT	2909677	10

Technical data

①
See diagram
18
8
10
Yellow LED, reverse polarity protection, freewheeling diode

AgNi
250 V AC/DC
5 V AC/DC
6 A
8 A
10 mA

4 kV AC (50 Hz, 1 min.)
-40 °C ... 60 °C
3 x 10⁷ cycles
IEC 60664 , EN 50178
3 / III

0.14 - 2.5 mm² / 0.14 - 2.5 mm² / 26 - 14
14 mm / 80 mm / 94 mm
Class A product, see page 605

Ordering data

Type	Order No.	Pcs./ Pkt.
PLC-RSC- 24DC/ 1- 1/ACT	2967109	10

Relay modules

Highly compact relay modules - PLC-INTERFACE

PLC actuator series for output functions

The PLC actuator series couples controllers and actuators such as motors, contactors, and valves.

The advantages:

- Direct connection of actuator to relay module including load return line
- No need for additional terminal blocks
- Space savings of up to 80%
- Time savings of up to 60%
- Screw and Push-in connection technology
- Relay modules with safe isolation according to DIN EN 50178 between coil and contact
- Functional plug-in bridges
- Efficient connection to system cabling using V8 adapter



Solid-state relay module with additional floating terminal point, DC output max. 3 A

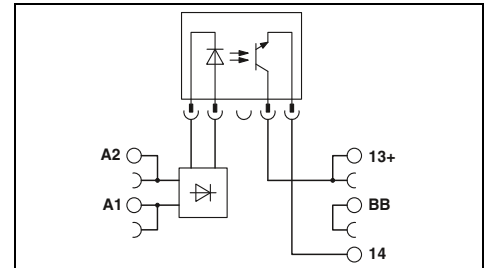

Technical data

Input data		①	②
Permissible range (with reference to U_N)		0.8 - 1.2	0.8 - 1.2
Switching level (with reference to U_N)	1 signal ("H")	≥ 0.8	≥ 0.8
	0 signal ("L")	≤ 0.25	≤ 0.4
Typical input current at U_N	[mA]	9.5	8.5
Typical response time/switch-on time at U_N	[ms]	0.02	0.02
Typical release time/switch-off time at U_N	[ms]	0.3	0.3
Transmission frequency f_{limit}	[Hz]	300	300
Input circuit DC		Yellow LED, reverse polarity protection, freewheeling diode	
Output data			
Max. switching voltage		33 V DC	
Minimum switching voltage		3 V DC	
Limiting continuous current		3 A (see derating curve)	
Maximum switch-on current		15 A (10 ms)	
Minimum switching current		-	
Output protection		Reverse polarity protection, surge protection	
Voltage drop at maximum limiting continuous current		≤ 200 mV	
Leakage current in off state		-	
Phase angle ($\cos \phi$)		-	
Max. load value		-	
General data			
Test voltage input/output		2.5 kV (50 Hz, 1 min.)	
Ambient temperature (operation)		-25 °C ... 60 °C	
Standards/regulations		IEC 60664 , EN 50178	
Degree of pollution/surge voltage category		2 / III	
Connection data solid/stranded/AWG		0.14 - 2.5 mm ² / 0.14 - 2.5 mm ² / 26 - 14	
Dimensions	W / H / D	6.2 mm / 80 mm / 94 mm	
EMC note		Class A product, see page 605	

Ordering data

Description	Input voltage U_N	Type	Order No.	Pcs./ Pkt.
PLC-INTERFACE, with screw connection	①	PLC-OSC- 5DC/ 24DC/ 2/ACT	2980144	10
	②	PLC-OSC- 24DC/ 24DC/ 2/ACT	2966676	10
PLC-INTERFACE, with Push-in connection	①	PLC-OPT- 5DC/ 24DC/2/ACT	2900375	10
	②	PLC-OPT- 24DC/ 24DC/2/ACT	2900376	10

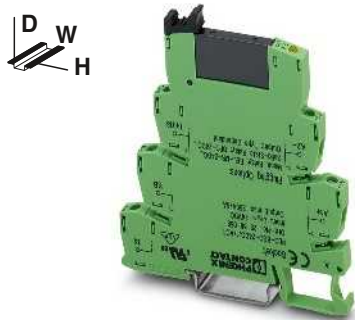

Solid-state relay module with additional floating terminal point, AC output max. 750 mA

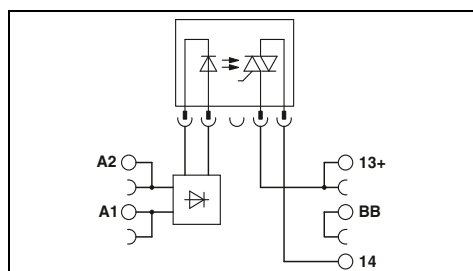

Technical data

- ②
- 0.8 -
- 1.2
- ≥ 0.8
- ≤ 0.25
- 9
- 3
- 9
- 10

Yellow LED, reverse polarity protection, freewheeling diode

253 V AC
 24 V AC
 0.75 A (see derating curve)
 30 A (10 ms)
 10 mA
 RCV circuit
 < 1 V

< 1 mA (in off state)
 0.5
 4.5 A²s

2.5 kV (50 Hz, 1 min.)
 -25 °C ... 60 °C
 IEC 60664 , EN 50178
 2 / III

0.14 - 2.5 mm² / 0.14 - 2.5 mm² / 26 - 14
 6.2 mm / 80 mm / 94 mm
 Class A product, see page 605

Ordering data

Type	Order No.	Pcs./ Pkt.
PLC-OSC- 24DC/230AC/ 1/ACT	2967947	10

Relay modules

Highly compact relay modules - PLC-INTERFACE

PLC actuator series for output functions

PLC actuator series with solid-state power relays for coupling the controller and actuators, such as motors, contactors, valves, etc.



Solid-state relay module with additional floating terminal point, DC output max. 5 A



Solid-state relay module with additional floating terminal point, AC output max. 2 A



Notes:	
Type of insulating housing: Polyamide PBT, non-reinforced, color: green.	
Marking systems and mounting material See Catalog 3	
The PLC-ATP partition plate must be installed for voltages larger than 250 V (L1, L2, L3) between identical terminal blocks in adjacent modules. Potential bridging is then carried out with FBST 8-PLC... or FBST 500....	
For derating curves see page 399	

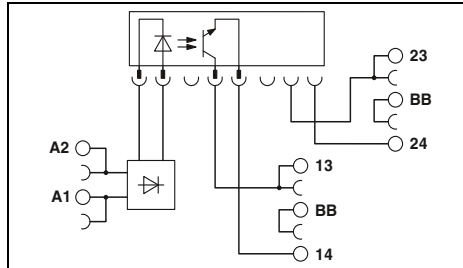

Technical data

Input data	①
Permissible range (with reference to U_N)	0.8 - 1.2
Switching level (with reference to U_N)	1 signal ("H") ≥ 0.8 0 signal ("L") ≤ 0.4
Typical input current at U_N	9 [mA]
Typical switch-on time at U_N	0.02 [ms]
Typical switch-off time at U_N	0.4 [ms]
Transmission frequency f_{limit}	300 [Hz]
Input circuit DC	Yellow LED, reverse polarity protection, freewheeling diode
Output data	
Maximum/minimum switching voltage	33 V DC / 3 V DC
Maximum switch-on current	15 A (10 ms)
Minimum/maximum switching current	- / 5 A (see derating curve)
Output protection	Reverse polarity protection, surge protection
Voltage drop at maximum limiting continuous current	≤ 200 mV
Leakage current in off state	-
Phase angle ($\cos \phi$)	-
Max. load value	-
General data	
Rated insulation voltage	-
Rated surge voltage	Basic insulation
Ambient temperature (operation)	-20 °C ... 60 °C
Standards/regulations	IEC 60664 , EN 50178
Degree of pollution/surge voltage category	2 / III
Mounting position/mounting	see derating / In rows with zero spacing
Connection data solid/stranded/AWG	0.14 - 2.5 mm ² / 0.14 - 2.5 mm ² / 26 - 14
Dimensions	14 mm / 80 mm / 94 mm
EMC note	Class A product, see page 605

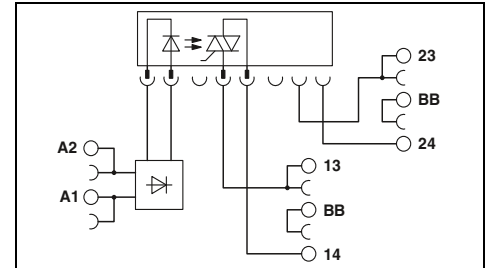

Technical data

Input data	①
Permissible range (with reference to U_N)	0.8 - 1.2
Switching level (with reference to U_N)	1 signal ("H") ≥ 0.8 0 signal ("L") ≤ 0.4
Typical input current at U_N	9 [mA]
Typical switch-on time at U_N	10 [ms]
Typical switch-off time at U_N	10 [ms]
Transmission frequency f_{limit}	10 [Hz]
Input circuit AC	Yellow LED, reverse polarity protection, freewheeling diode
Output data	
Maximum/minimum switching voltage	253 V AC / 24 V AC
Maximum switch-on current	30 A (10 ms)
Minimum/maximum switching current	25 mA / 2 A (see derating curve)
Output protection	Surge protection
Voltage drop at maximum limiting continuous current	≤ 1 V
Leakage current in off state	typ. 1 mA
Phase angle ($\cos \phi$)	0.5
Max. load value	4 A ² s (tp = 10 ms, at 25 °C)
General data	
Rated insulation voltage	-
Rated surge voltage	Basic insulation
Ambient temperature (operation)	-20 °C ... 60 °C
Standards/regulations	IEC 60664 , EN 50178
Degree of pollution/surge voltage category	2 / III
Mounting position/mounting	see derating / In rows with zero spacing
Connection data solid/stranded/AWG	0.14 - 2.5 mm ² / 0.14 - 2.5 mm ² / 26 - 14
Dimensions	14 mm / 80 mm / 94 mm
EMC note	Class A product, see page 605

Ordering data

Description	Input voltage U_N	Type	Order No.	Pcs./Pkt.
PLC-INTERFACE, with screw connection ①	24 V DC	PLC-OSC- 24DC/ 24DC/ 5/ACT	2982786	10

Ordering data

Description	Input voltage U_N	Type	Order No.	Pcs./Pkt.
PLC-INTERFACE, with screw connection ①	24 V AC	PLC-OSC- 24DC/230AC/ 2/ACT	2982760	10

PLC actuator series for output functions

PLC actuator basic terminal blocks that can be fitted with a mechanical or solid-state relay. For coupling the controller and actuators, such as motors, contactors, valves, etc.

Notes:
Maximum interrupting rating diagrams, see page 400
For derating curves see page 399
When mounting relays on a DIN rail base or PCB, data may be limited, especially with regard to the limiting continuous current and/or ambient temperature range. See "General" section in "Basics of relay technology" on page 286.



Basic terminal block with additional floating terminal point for assembly with relay



Basic terminal block with additional floating terminal point for assembly with solid-state relay

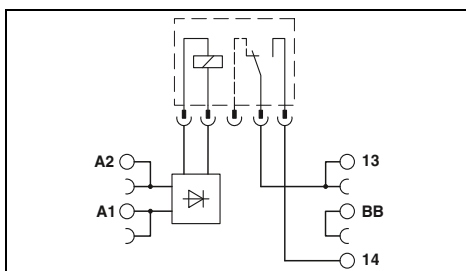

Technical data

Input data	0.8 ... 1.2
Permissible range (with reference to U_N)	15.6 mA / 8.5 mA
Typical input current at U_N (50/60 Hz)	5 ms
Typical response time at U_N	30 ms
Typical release time at U_N	Yellow LED , Bridge rectifier
Input circuit	REL-MR-24DC/21AU
Output data with:	REL-MR-24DC/21
Contact type	Single contact, 1 N/O contact
Contact material	AgSnO, hard gold-plated
Max. switching voltage	30 V AC / 36 V DC
Minimum switching voltage	100 mV (at 10 mA)
Limiting continuous current	50 mA
Minimum switching current	1 mA (at 24 V)
Output protection	-
Voltage drop at limiting continuous current	-
Leakage current in off state	-
Max. load value $I^2 \times t$ (t = 10 ms)	-
General data	
Rated insulation voltage	250 V AC
Rated surge voltage/insulation	6 kV / Safe isolation, increased insulation
Ambient temperature (operation)	-20 °C ... 60 °C
Air clearances and creepage distances	EN 50178
Degree of pollution / Overvoltage category	2 / III
Connection data solid/stranded/AWG	0.14 - 2.5 mm ² / 0.14 - 2.5 mm ² / 26 - 14
Dimensions	W / H / D 6.2 mm / 80 mm / 94 mm

Ordering data

Description	Voltage U_N	Type	Order No.	Pcs./ Pkt.
PLC-INTERFACE, with screw connection	24 V AC/DC	PLC-BSC- 24UC/ 1/ACT	2982799	10
PLC-INTERFACE, with Push-in connection	24 V AC/DC	PLC-BPT- 24UC/ 1/ACT	2900450	10

Accessories

Description	Order No.	Pcs./ Pkt.
Plug-in miniature power relays, with multi-layer gold contacts		
REL-MR- 24DC/21AU	2961121	10
REL-MR- 24DC/21	2961105	10
Plug-in solid-state relays		
Solid-state input relays		
Solid-state power relays		
Solid-state power relays		

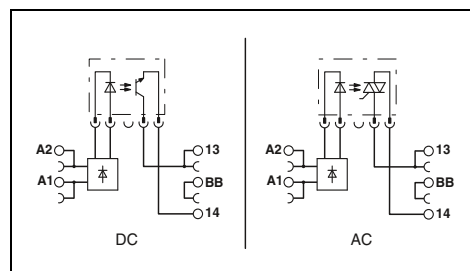

Technical data

Input data	0.8 ... 1.2
Permissible range (with reference to U_N)	15 mA / 8.3 mA
Typical input current at U_N (50/60 Hz)	5 ms
Typical response time at U_N	20 ms
Typical release time at U_N	Yellow LED , Bridge rectifier
Input circuit	OPT...48DC/...
Output data with:	OPT...24DC/...
Contact type	OPT...230AC/...
Contact material	-
Max. switching voltage	48 V DC
Minimum switching voltage	3 V DC
Limiting continuous current	100 mA
Minimum switching current	1 mA (at 24 V)
Output protection	-
Voltage drop at limiting continuous current	-
Leakage current in off state	-
Max. load value $I^2 \times t$ (t = 10 ms)	-
General data	
Rated insulation voltage	250 V AC
Rated surge voltage/insulation	6 kV / Safe isolation, increased insulation
Ambient temperature (operation)	-20 °C ... 60 °C
Air clearances and creepage distances	EN 50178
Degree of pollution / Overvoltage category	2 / III
Connection data solid/stranded/AWG	0.14 - 2.5 mm ² / 0.14 - 2.5 mm ² / 26 - 14
Dimensions	W / H / D 6.2 mm / 80 mm / 94 mm

Ordering data

Description	Voltage U_N	Type	Order No.	Pcs./ Pkt.
PLC-INTERFACE, with screw connection	24 V AC/DC	PLC-BSC- 24UC/ 1/ACT	2982799	10
PLC-INTERFACE, with Push-in connection	24 V AC/DC	PLC-BPT- 24UC/ 1/ACT	2900450	10

Accessories

Description	Order No.	Pcs./ Pkt.
Plug-in miniature power relays, with multi-layer gold contacts		
REL-MR- 24DC/21AU	2961121	10
REL-MR- 24DC/21	2961105	10
Plug-in solid-state relays		
Solid-state input relays		
Solid-state power relays		
Solid-state power relays		

Relay modules

Highly compact relay modules - PLC-INTERFACE

PLC sensor series for input functions

PLC sensor series for coupling controller and sensors, such as proximity switches, limit switches or auxiliary contacts

The advantages:

- Direct connection of sensor to relay module including sensor supply
- No need for additional terminal blocks
- Space savings of up to 80%
- Time savings of up to 60%
- Screw and Push-in connection technology
- Relay modules with safe isolation according to DIN EN 50178 between coil and contact
- Functional plug-in bridges
- Efficient connection to system cabling using V8 adapter

Notes:
Type of insulating housing: Polyamide PBT, non-reinforced, color: green.
Marking systems and mounting material See Catalog 3
The PLC-ATP partition plate must be installed for voltages larger than 250 V (L1, L2, L3) between identical terminal blocks in adjacent modules. Potential bridging is then carried out with FBST 8-PLC... or FBST 500....
For diagrams of operating voltage ranges, see page 397
1) 120 and 230 V types up to 55 °C
2) If the specified maximum values are exceeded for multi-layer contact relays, the gold layer will be destroyed. During further use, the maximum values of the power contact relays apply. This may then result in a shorter service life than a dedicated power contact.



1-N/O relay module with additional floating terminal point

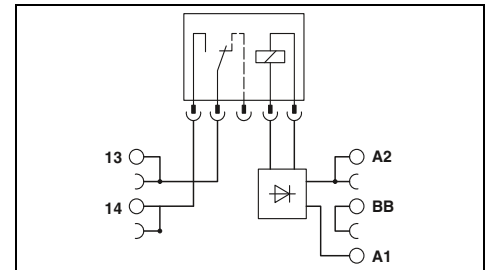

Technical data

Input data	①	②	③	
Permissible range (with reference to U_N)	See diagram			
Switching level (with reference to U_N)	1 signal ("H") 0 signal ("L")			
Typical input current at U_N	[mA]	9	3.5	3.2
Typical response time/switch-on time at U_N	[ms]	5	6	7
Typical release time/switch-off time at U_N	[ms]	8	15	15
Transmission frequency f_{limit}	[Hz]			
Input circuit DC	Yellow LED, reverse polarity protection, freewheeling diode			
Input circuit AC/DC	Yellow LED, bridge rectifier			
Output data				
Contact material	AgSnO, hard gold-plated			
Max. switching voltage	30 V AC / 36 V DC			
Minimum switching voltage	100 mV (at 10 mA)			
Limiting continuous current	50 mA			
Maximum switch-on current	50 mA			
Minimum switching current	1 mA (at 24 V)			
Output protection	-			
Voltage drop at maximum limiting continuous current	-			
General data				
Test voltage input/output	4 kV AC (50 Hz, 1 min.)			
Ambient temperature (operation)	-40 °C ... 60 °C ¹⁾			
Mechanical service life	2 x 10 ⁷ cycles			
Standards/regulations	IEC 60664, EN 50178			
Degree of pollution/surge voltage category	3 / III			
Connection data solid/stranded/AWG	0.14 - 2.5 mm ² / 0.14 - 2.5 mm ² / 26 - 14			
Dimensions	W / H / D			
EMC note	Class A product, see page 605			

Ordering data

Description	Input voltage U_N	Type	Order No.	Pcs./ Pkt.
PLC-INTERFACE, with screw connection				
	① 24 V DC	PLC-RSC- 24DC/ 1AU/SEN	2966317	10
	② 120 V AC / 110 V DC	PLC-RSC-120UC/ 1AU/SEN	2966320	10
	③ 230 V AC / 220 V DC	PLC-RSC-230UC/ 1AU/SEN	2966333	10
PLC-INTERFACE, with Push-in connection				
	① 24 V DC	PLC-RPT- 24DC/ 1AU/SEN	2900313	10
	② 120 V AC / 110 V DC	PLC-RPT-120UC/ 1AU/SEN	2900314	10
	③ 230 V AC / 220 V DC	PLC-RPT-230UC/ 1AU/SEN	2900315	10

new



1-N/O relay module with manual operation and additional floating terminal point



Solid-state relay module with additional floating terminal point, DC output max. 100 mA

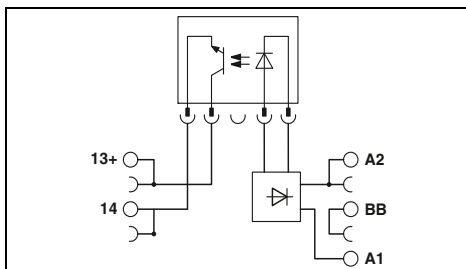
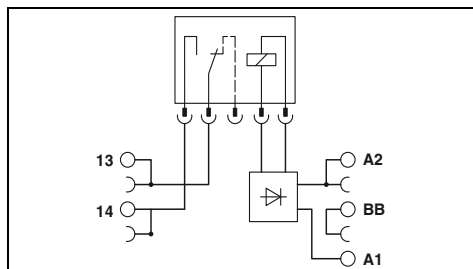

Technical data

①	②	③
See diagram		
9	3.5	3.2
5	6	7
8	15	15

Yellow LED, reverse polarity protection, freewheeling diode
Yellow LED, bridge rectifier

AgSnO, hard gold-plated
30 V AC / 36 V DC
100 mV (at 10 mA)
50 mA²
50 mA²
1 mA (at 24 V)
-
-

4 kV AC (50 Hz, 1 min.)
-40 °C ... 60 °C)
1 x 10⁷ cycles
IEC 60664, EN 50178
3 / III
0.14 - 2.5 mm² / 0.14 - 2.5 mm² / 26 - 14
6.2 mm / 80 mm / 94 mm
Class A product, see page 605

Technical data

①	②	③
0.8 - 1.2	0.8 - 1.1	0.8 - 1.1
≥ 0.8	≥ 0.8	≥ 0.8
≤ 0.4	≤ 0.3	≤ 0.3
8.5	3.5	3.5
0.02	6	3
0.3	10	5
300	10	10

Yellow LED, reverse polarity protection, freewheeling diode
Yellow LED, bridge rectifier

-
48 V DC
3 V DC
100 mA
-
-
Reverse polarity protection, surge protection
≤ 1 V

2.5 kV (50 Hz, 1 min.)
-25 °C ... 60 °C
-
IEC 60664, EN 50178
2 / III
0.14 - 2.5 mm² / 0.14 - 2.5 mm² / 26 - 14
6.2 mm / 80 mm / 94 mm
Class A product, see page 605

Ordering data

Type	Order No.	Pcs./ Pkt.
PLC-RSC- 24DC/ 1AU/MS/SEN	2909663	10
PLC-RSC-120UC/ 1AU/MS/SEN	2909664	10
PLC-RSC-230UC/ 1AU/MS/SEN	2909665	10
PLC-RPT- 24DC/ 1AU/MS/SEN	2909678	10
PLC-RPT-120UC/ 1AU/MS/SEN	2909679	10
PLC-RPT-230UC/ 1AU/MS/SEN	2909680	10

Ordering data

Type	Order No.	Pcs./ Pkt.
PLC-OSC- 24DC/ 48DC/100/SEN	2966773	10
PLC-OSC-120UC/ 48DC/100/SEN	2966799	10
PLC-OSC-230UC/ 48DC/100/SEN	2966809	10
PLC-OPT- 24DC/ 48DC/100/SEN	2900358	10
PLC-OPT-120UC/ 48DC/100/SEN	2900359	10
PLC-OPT-230UC/ 48DC/100/SEN	2900361	10

Relay modules

Highly compact relay modules - PLC-INTERFACE

PLC-INTERFACE for high inrush currents

PLC relay modules for high inrush currents due, for example, to capacitive loads.

The advantages:

- Maximum switch-on current 130 A
- Direct connection of load return line thanks to actuator type
- Screw and Push-in connection technology
- Safe isolation according to DIN EN 50178 between coil and contact
- Functional plug-in bridges
- Efficient connection to system cabling using V8 adapter

Notes:
Type of insulating housing: Polyamide PBT, non-reinforced, color: green.
Marking systems and mounting material See Catalog 3
The PLC-ATP partition plate must be installed for voltages larger than 250 V (L1, L2, L3) between identical terminal blocks in adjacent modules. Potential bridging is then carried out with FBST 8-PLC... or FBST 500....
For diagrams of operating voltage ranges, see page 397



1-N/O relay module with additional floating terminal point, max. 130 A peak

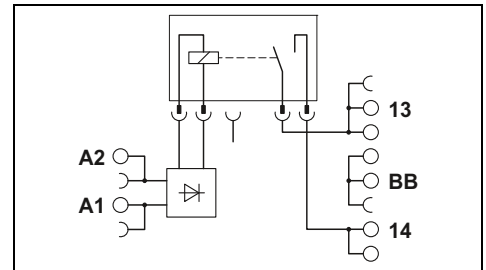

Basic behavior of capacitive loads:
- Very high input current
- Voltage increases with an e-function

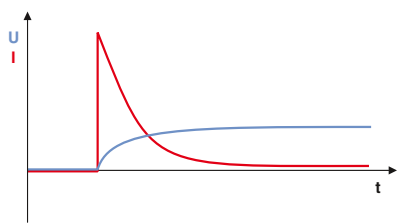

Input data	
Typical input current at U_N	[mA]
Response/release time at U_N	[ms]
Input circuit DC	
Output data	
Contact material	
Max. switching voltage	
Minimum switching voltage	
Maximum switch-on current	
General data	
Test voltage input/output	
Ambient temperature (operation)	
Mechanical service life	
Standards/regulations	
Connection data solid/stranded/AWG	
Dimensions	W / H / D
EMC note	

Technical data	
①	18
	8 / 10
	Yellow LED, reverse polarity protection, freewheeling diode
	AgSnO
	250 V AC/DC
	12 V AC/DC (at 100 mA)
	80 A (for 20 ms) / 130 A (peak, at capacitive load, 230 V AC, 24 μF)
	4 kV AC (50 Hz, 1 min.)
	-40 °C ... 60 °C
	3 x 10 ⁷ cycles
	IEC 60664 , EN 50178
	0.14 - 2.5 mm ² / 0.14 - 2.5 mm ² / 26 - 14
	14 mm / 80 mm / 94 mm
	Class A product, see page 605

Description	Input voltage U_N
PLC-INTERFACE, with screw connection ①	24 V DC
PLC-INTERFACE, with Push-in connection ①	24 V DC

Ordering data		
Type	Order No.	Pcs./Pkt.
PLC-RSC- 24DC/ 11C/ACT	2967604	10
PLC-RPT- 24DC/ 11C/ACT	2900298	10

Maximum interrupting rating

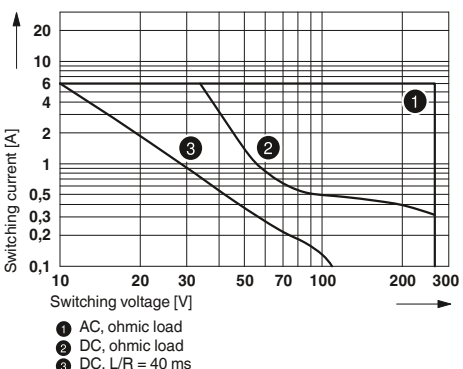

PLC-INTERFACE for high continuous currents

PLC relay modules for high continuous switching currents

The advantages:

- Maximum continuous current 10 A
- Safe isolation according to DIN EN 50178 between coil and contact
- Screw and Push-in connection technology
- Functional plug-in bridges
- Efficient connection to system cabling using V8 adapter
- Long electrical service life thanks to 16 A relay
- All common input voltages of 12 V DC to 230 V AC

Notes:	
Type of insulating housing: Polyamide PBT, non-reinforced, color: green.	
Marking systems and mounting material See Catalog 3	
The PLC-ATP partition plate must be installed for voltages larger than 250 V (L1, L2, L3) between identical terminal blocks in adjacent modules. Potential bridging is then carried out with FBST 8-PLC... or FBST 500....	
For diagrams of operating voltage ranges, see page 397	
*) 230 V types up to 55 °C	



1-PDT relay module, max. 10 A

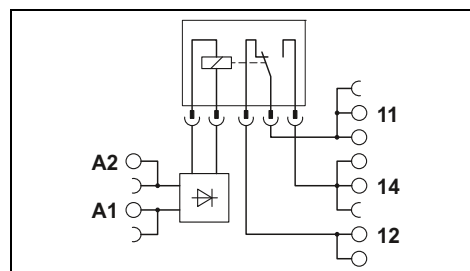

Technical data

Input data	①	②	③	④	⑤	⑥	⑦
Typical input current at U_N [mA]	33	18	17.5	20	10	4.5	4.5
Response/release time at U_N [ms]	8 / 10	8 / 10	8 / 10	8 / 10	8 / 10	7 / 10	7 / 10
Input circuit DC	Yellow LED, reverse polarity protection, freewheeling diode						
Input circuit AC/DC	Yellow LED, bridge rectifier						
Output data							
Contact material	AgNi						
Max. switching voltage	250 V AC/DC						
Minimum switching voltage	12 V AC/DC						
Limiting continuous current	10 A						
Maximum switch-on current	30 A (300 ms)						
Minimum switching current	100 mA						
General data							
Test voltage input/output	4 kV AC (50 Hz, 1 min.)						
Ambient temperature (operation)	-40 °C ... 60 °C*)						
Mechanical service life	3 x 10 ⁷ cycles						
Standards/regulations	IEC 60664, EN 50178						
Connection data solid/stranded/AWG	0.14 - 2.5 mm ² / 0.14 - 2.5 mm ² / 26 - 14						
Dimensions	14 mm / 80 mm / 94 mm						W / H / D
EMC note	Class A product, see page 605						

Ordering data

Description	Input voltage U_N	Type	Order No.	Pcs./Pkt.
PLC-INTERFACE, with screw connection				
①	12 V DC	PLC-RSC- 12DC/21HC	2967617	10
②	24 V DC	PLC-RSC- 24DC/21HC	2967620	10
③	24 V AC/DC	PLC-RSC- 24UC/21HC	2967633	10
④	48 V DC	PLC-RSC- 48DC/21HC	2967646	10
⑤	60 V DC	PLC-RSC- 60DC/21HC	2967659	10
⑥	120 V AC / 110 V DC	PLC-RSC-120UC/21HC	2967662	10
⑦	230 V AC / 220 V DC	PLC-RSC-230UC/21HC	2967675	10
PLC-INTERFACE, with Push-in connection				
①	12 V DC	PLC-RPT- 12DC/21HC	2900290	10
②	24 V DC	PLC-RPT- 24DC/21HC	2900291	10
③	24 V AC/DC	PLC-RPT- 24UC/21HC	2900293	10
④	48 V DC	PLC-RPT- 48DC/21HC	2900294	10
⑤	60 V DC	PLC-RPT- 60DC/21HC	2900295	10
⑥	120 V AC / 110 V DC	PLC-RPT-120UC/21HC	2900296	10
⑦	230 V AC / 220 V DC	PLC-RPT-230UC/21HC	2900297	10

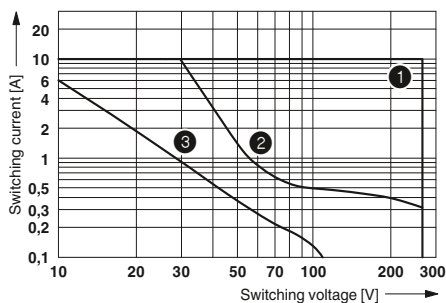

- ① AC, ohmic load
- ② DC, ohmic load
- ③ DC, L/R = 40 ms

Max. interrupting rating

Relay modules

Highly compact relay modules - PLC-INTERFACE

Basic terminal blocks with interference current filter that can be fitted with relays

PLC basic terminal blocks with integrated filter to protect against interference voltages or currents due, for example, to long control lines.

The advantages:

- Resistant to interference currents
 - High relay release voltage
- Typical applications:
- Applications with long control lines
 - Use of AC output boards, resulting in residual AC currents
 - Screw and Push-in connection technology

Notes:
Type of insulating housing: Polyamide PBT, non-reinforced, color: green.
Marking systems and mounting material See Catalog 3
The PLC-ATP partition plate must be installed for voltages larger than 250 V (L1, L2, L3) between identical terminal blocks in adjacent modules. Potential bridging is then carried out with FBST 8-PLC... or FBST 500....
For diagrams of operating voltage ranges, see page 397
Maximum interrupting rating diagrams, see page 400
When mounting relays on a DIN rail base or PCB, data may be limited, especially with regard to the limiting continuous current and/or ambient temperature range. See "General" section in "Basics of relay technology" on page 286.



Basic terminal block with input filter

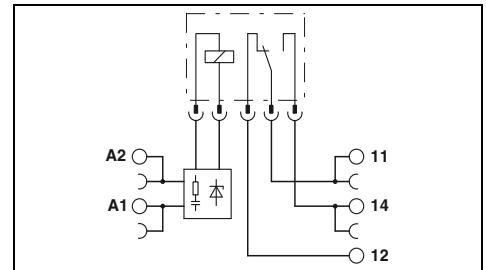

Technical data

Input data	120 V AC	230 V AC
Nominal input voltage U_N	0.8 ... 1.4	0.78 ... 1.14
Permissible range (with reference to U_N)	50 V AC	80 V AC
Typical release voltage (relay assembly)	7 mA / 8 mA	8.8 mA / 10 mA
Typical input current at U_N (50/60 Hz)	7 ms	7 ms
Typical response time at U_N	20 ms	20 ms
Typical release time at U_N	Input circuit	
Input circuit	Yellow LED, Bridge rectifier, Filter	
Output data with:	REL-MR-60DC/21	REL-MR-60DC/21AU
Contact type	Single contact, 1-PDT	Single contact, 1-PDT
Contact material	AgSnO	AgSnO, hard gold-plated
Max. switching voltage	250 V AC/DC	30 V AC / 36 V DC
Minimum switching voltage	5 V (at 100 mA)	100 mV (at 10 mA)
Limiting continuous current	6 A	50 mA
Maximum switch-on current	on request	50 mA
Minimum switching current	10 mA (at 12 V)	1 mA (at 24 V)
General data	4 kV (50 Hz, 1 min.)	
Test voltage input/output	-20 °C ... 55 °C	
Ambient temperature (operation)	2 x 10 ⁷ cycles	
Mechanical service life	IEC 60664, EN 50178	
Standards/regulations	3 / III	
Degree of pollution / Overvoltage category	0.14 - 2.5 mm ² / 0.14 - 2.5 mm ² / 26 - 14	
Connection data solid/stranded/AWG	6.2 mm / 80 mm / 94 mm	
Dimensions	W / H / D	
EMC note	Class A product, see page 605	

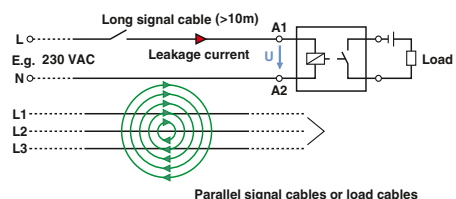
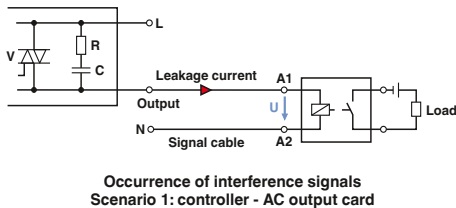

Description	Voltage U_N
PLC-INTERFACE basic terminal block, for plug-in miniature relays or solid-state relays	
with screw connection	120 V AC
with screw connection	230 V AC
with Push-in connection	120 V AC
with Push-in connection	230 V AC

Plug-in miniature power relays, with multi-layer gold contacts

Ordering data		
Type	Order No.	Pcs./ Pkt.
PLC-BSC-120UC/21/SO46	2980319	10
PLC-BSC-230UC/21/SO46	2980335	10
PLC-BPT-120UC/21/SO46	2900453	10
PLC-BPT-230UC/21/SO46	2900455	10

Accessories		
Type	Order No.	Pcs./ Pkt.
REL-MR- 60DC/21AU	2961134	10
REL-MR- 60DC/21	2961118	10

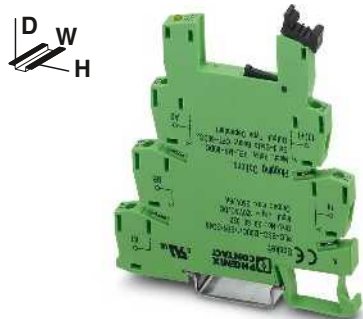

Basic terminal block with additional floating terminal point and input filter

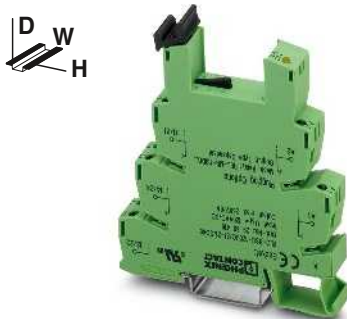

2-PDT basic terminal block with input filter

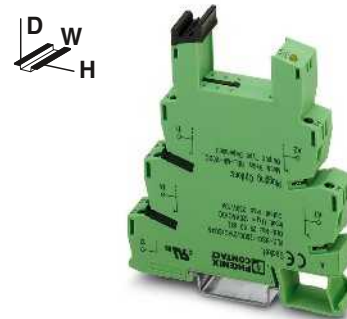

1-PDT basic terminal block for high continuous currents with input filter

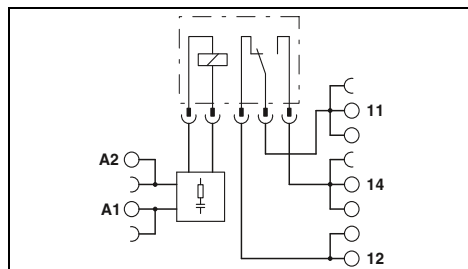
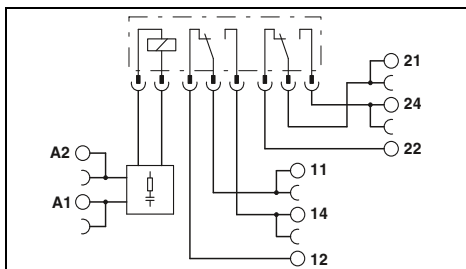
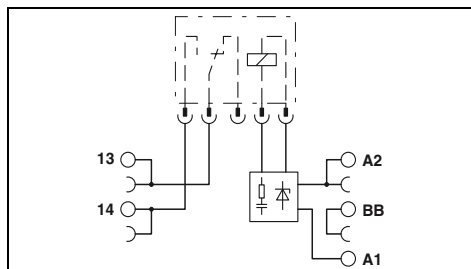

Technical data

Technical data

Technical data

120 V AC	230 V AC
0.8 ... 1.4	0.78 ... 1.14
50 V AC	80 V AC
7 mA / 8 mA	8.8 mA / 10 mA
7 ms	7 ms
20 ms	20 ms
Yellow LED, Bridge rectifier, Filter	
REL-MR-60DC/21	REL-MR-60DC/21AU
Single contact, 1 N/O contact	Single contact, 1 N/O contact
AgSnO	AgSnO, hard gold-plated
250 V AC/DC	30 V AC / 36 V DC
5 V (at 100 mA)	100 mV (at 10 mA)
6 A	50 mA
on request	50 mA
10 mA (at 12 V)	1 mA (at 24 V)

120 V AC	230 V AC
0.78 ... 1.4	0.78 ... 1.14
16 V AC	70 V AC
6 mA / 7 mA	8.5 mA / 10 mA
7 ms	7 ms
10 ms	10 ms
Yellow LED, Bridge rectifier, Filter	
REL-MR-110DC/21-21	REL-MR-110DC/21-21AU
Single contact, 2-PDT	Single contact, 2-PDT
AgNi	AgNi, + 5 µm Au
250 V AC/DC	30 V AC / 36 V DC
5 V AC/DC	100 mV
6 A	50 mA
15 A (300 ms)	50 mA
10 mA	1 mA

120 V AC	230 V AC
0.85 ... 1.4	0.78 ... 1.14
16 V AC	70 V AC
6 mA / 7 mA	8.5 mA / 10 mA
7 ms	7 ms
20 ms	20 ms
Yellow LED, Bridge rectifier, Filter	
REL-MR-110DC/21HC	REL-MR-110DC/21HC
Single contact, 1-PDT	Single contact, 1-PDT
AgNi	AgNi
250 V AC/DC	250 V AC/DC
12 V AC/DC	12 V AC/DC
10 A	10 A
30 A (300 ms)	30 A (300 ms)
100 mA	100 mA

4 kV (50 Hz, 1 min.)
 -20 °C ... 55 °C
 2 x 10⁷ cycles
 IEC 60664, EN 50178
 3 / III

4 kV (50 Hz, 1 min.)
 -20 °C ... 55 °C
 3 x 10⁷ cycles
 IEC 60664, EN 50178
 3 / III

4 kV (50 Hz, 1 min.)
 -20 °C ... 55 °C
 3 x 10⁷ cycles
 IEC 60664, EN 50178
 3 / III

0.14 - 2.5 mm² / 0.14 - 2.5 mm² / 26 - 14
 6.2 mm / 80 mm / 94 mm
 Class A product, see page 605

0.14 - 2.5 mm² / 0.14 - 2.5 mm² / 26 - 14
 14 mm / 80 mm / 94 mm
 Class A product, see page 605

0.14 - 2.5 mm² / 0.14 - 2.5 mm² / 26 - 14
 14 mm / 80 mm / 94 mm
 Class A product, see page 605

Ordering data

Ordering data

Ordering data

Type	Order No.	Pcs./ Pkt.
PLC-BSC-120UC/ 1/SEN/SO46	2980322	10
PLC-BSC-230UC/ 1/SEN/SO46	2980348	10
PLC-BPT-120UC/ 1/SEN/SO46	2900456	10
PLC-BPT-230UC/ 1/SEN/SO46	2900457	10

Type	Order No.	Pcs./ Pkt.
PLC-BSC-120UC/21-21/SO46	2980416	10
PLC-BSC-230UC/21-21/SO46	2980429	10

Type	Order No.	Pcs./ Pkt.
PLC-BSC-120UC/21HC/SO46	2980432	10
PLC-BSC-230UC/21HC/SO46	2980445	10

Accessories

Accessories

Accessories

REL-MR- 60DC/21AU	2961134	10
REL-MR- 60DC/21	2961118	10

REL-MR-110DC/21-21AU	2961228	10
REL-MR-110DC/21-21	2961202	10

REL-MR-110DC/21HC	2961338	10
-------------------	---------	----

Relay modules

Highly compact relay modules - PLC-INTERFACE

Basic terminal blocks with interference current filter that can be fitted with solid-state relays

PLC basic terminal blocks with integrated filter to protect against interference voltages or currents due, for example, to long control lines.

The advantages:

- Resistant to interference currents
 - High relay release voltage
- Typical applications:
- Applications with long control lines
 - Use of AC output boards, resulting in residual AC currents
 - Screw and Push-in connection technology

Notes:
Type of insulating housing: Polyamide PBT, non-reinforced, color: green.
Marking systems and mounting material See Catalog 3
The PLC-ATP partition plate must be installed for voltages larger than 250 V (L1, L2, L3) between identical terminal blocks in adjacent modules. Potential bridging is then carried out with FBST 8-PLC... or FBST 500....
For diagrams of operating voltage ranges, see page 397
Maximum interrupting rating diagrams, see page 400
When mounting relays on a DIN rail base or PCB, data may be limited, especially with regard to the limiting continuous current and/or ambient temperature range. See "General" section in "Basics of relay technology" on page 286.



Basic terminal block with Input filter

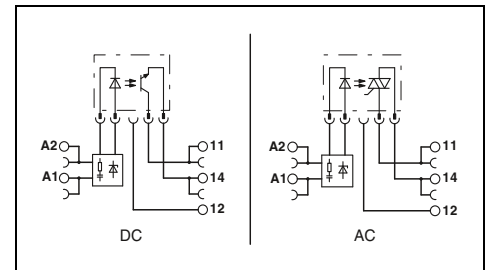

Input data
Nominal input voltage U_N
Permissible range (with reference to U_N)
Switching level (with optocoupler) 0 signal ("L")
Typical input current at U_N (50/60 Hz)
Typical response time/switch-on time at U_N
Typical switch-off time at U_N
Input circuit
Output data with:
Max. switching voltage
Minimum switching voltage
Limiting continuous current
Maximum switch-on current
Output protection
Voltage drop at limiting continuous current
Leakage current in off state
Maximum phase shift (inductive consumer)
Max. load value $I^2 \times t$ (t = 10 ms)
General data
Test voltage input/output
Ambient temperature (operation)
Standards/regulations
Degree of pollution / Overvoltage category
Connection data solid/stranded/AWG
Dimensions
EMC note

Technical data		
120 V AC	230 V AC	
0.85 ... 1.1	0.8 ... 1.1	
≤ 0.4	≤ 0.4	
7 mA / 8 mA	8.8 mA / 10 mA	
6 ms	6 ms	
10 ms	10 ms	
Yellow LED, Bridge rectifier, Filter		
OPT...48DC/...	OPT...24DC/...	OPT...230AC/...
48 V DC	30 V DC	253 V AC
3 V DC	3 V DC	24 V AC
100 mA	3 A	0.75 A
	15 A (10 ms)	30 A (10 ms)
Reverse polarity protection, surge protection	Reverse polarity protection, surge protection	RCV circuit
< 1 V	< 200 mV	< 1 V
-	-	< 1 mA
-	-	0.5
-	-	4.5 A ² s
2.5 kV (50 Hz, 1 min.)		
-20 °C ... 55 °C		
IEC 60664, EN 50178		
2 / III		
0.14 - 2.5 mm ² / 0.14 - 2.5 mm ² / 26 - 14		
6.2 mm / 80 mm / 94 mm		
Class A product, see page 605		

Description	Voltage U_N
PLC-INTERFACE basic terminal block , for plug-in miniature relays or solid-state relays	
with screw connection	120 V AC
with screw connection	230 V AC
with Push-in connection	120 V AC
with Push-in connection	230 V AC

Ordering data			
Type	Order No.	Pcs./Pkt.	
PLC-BSC-120UC/21/SO46	2980319	10	
PLC-BSC-230UC/21/SO46	2980335	10	
PLC-BPT-120UC/21/SO46	2900453	10	
PLC-BPT-230UC/21/SO46	2900455	10	

Plug-in solid-state relays	
Solid-state input relays	
Solid-state power relays	
Solid-state power relays	

Accessories		
OPT-60DC/ 48DC/100	2966621	10
OPT-60DC/ 24DC/ 2	2966605	10
OPT-60DC/230AC/ 1	2967963	10



Basic terminal block with additional floating terminal point and Input filter

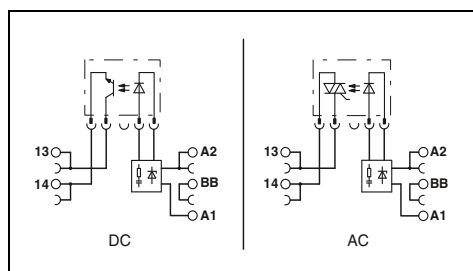

Technical data

120 V AC	230 V AC
0.85 ... 1.1	0.8 ... 1.1
≤ 0.4	≤ 0.4
7 mA / 8 mA	8.8 mA / 10 mA
6 ms	6 ms
10 ms	10 ms
Yellow LED, Bridge rectifier, Filter	
OPT...48DC/...	OPT...24DC/...
48 V DC	30 V DC
3 V DC	253 V AC
100 mA	24 V AC
	3 A
	0.75 A
	15 A (10 ms)
	30 A (10 ms)
Reverse polarity protection, surge protection	Reverse polarity protection, surge protection
< 1 V	< 200 mV
-	< 1 V
-	< 1 mA
-	0.5
-	4.5 A²s

2.5 kV (50 Hz, 1 min.)
 -20 °C ... 55 °C
 IEC 60664, EN 50178
 2 / III

0.14 - 2.5 mm² / 0.14 - 2.5 mm² / 26 - 14
 6.2 mm / 80 mm / 94 mm
 Class A product, see page 605

Ordering data

Type	Order No.	Pcs./ Pkt.
PLC-BSC-120UC/ 1/SEN/SO46	2980322	10
PLC-BSC-230UC/ 1/SEN/SO46	2980348	10
PLC-BPT-120UC/ 1/SEN/SO46	2900456	10
PLC-BPT-230UC/ 1/SEN/SO46	2900457	10

Accessories

OPT-60DC/ 48DC/100	2966621	10
OPT-60DC/ 24DC/ 2	2966605	10
OPT-60DC/230AC/ 1	2967963	10

Plug-in miniature power relays

new

Plug-in miniature power relays are suitable for PLC-INTERFACE and RIF-0 and RIF-1 relay base.

The advantages:

- Power contacts up to 16 A
- Multi-layer gold contact or power contact
- High degree of protection up to RT III depending on type (wash-proof)
- Safe isolation according to DIN EN 50178 between coil and contact



1-PDT relay,
6 A, maximum



1-PDT relay with
manual operation,
max. 6 A

Notes:
If the specified maximum values for multi-layer contact relays are exceeded, the gold plating is destroyed. The maximum values of the power contact relay are then valid. This can result in a shorter service life than with a pure power contact.
For dimensional drawings and perforations for assembly, see page 398
For diagrams of operating voltage ranges, see page 397
When mounting relays on a DIN rail base or PCB, data may be limited, especially with regard to the limiting continuous current and/or ambient temperature range. See "General" section in "Basics of relay technology" on page 286.

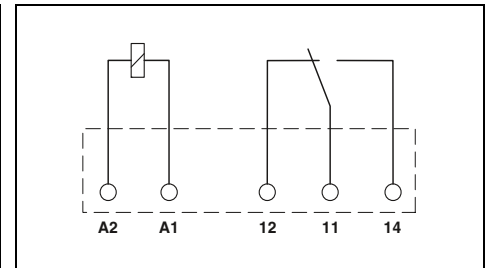
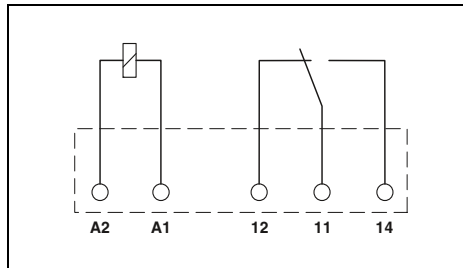

	Technical data					Technical data		
	①	②	③	④	⑤	②	④	⑤
Input data	see diagram					see diagram		
Permissible range (with reference to U_N)								
Typical input current at U_N [mA]	38	14	9	7	3	14	7	3
Typical response time at U_N [ms]	5	5	5	5	5	5	5	5
Typical release time at U_N [ms]	2.5	2.5	2.5	2.5	2.5	2.5	2.5	2.5
Output data								
Contact type	1 PDT		1 PDT			1 PDT		1 PDT
Contact material	AgSnO		AgSnO, hard gold-plated			AgSnO		AgSnO, hard gold-plated
Max. switching voltage	250 V AC/DC		30 V AC / 36 V DC			250 V AC/DC		30 V AC / 36 V DC
Minimum switching voltage	5 V (at 100 mA)		100 mV (at 10 mA)			5 V (at 100 mA)		100 mV (at 10 mA)
Limiting continuous current	6 A		50 mA			6 A		50 mA
Maximum switch-on current	10 A (4 s)		on request			10 A (4 s)		50 mA
Minimum switching current	10 mA (at 12 V)		1 mA (at 24 V)			10 mA (at 12 V)		1 mA (at 24 V)
Maximum interrupting rating, ohmic load	24 V DC 48 V DC 60 V DC 110 V DC 220 V DC 250 V AC		140 W 20 W - - 40 W 1500 VA			140 W 20 W 18 W 23 W 40 W 1500 VA		1.2 W - - - - -
General data								
Test voltage (winding / contact)	4 kV AC (50 Hz, 1 min.)					4 kV AC (50 Hz, 1 min.)		
Ambient temperature (operation)	-40 °C ... 85 °C					-40 °C ... 85 °C		
Nominal operating mode	100% operating factor					100% operating factor		
Mechanical service life	2 x 10 ⁷ cycles					1 x 10 ⁷ cycles		
Standards/regulations	IEC 60664 , EN 50178 , EN 61810-1					IEC 60664 , EN 50178 , EN 61810-1		
Mounting position/mounting	any / In rows with zero spacing					any / In rows with zero spacing		
Dimensions	W / H / D		5 mm / 28 mm / 15 mm			5 mm / 28 mm / 16 mm		

Description	Input voltage U_N	Ordering data			Type	Order No.	Pcs./ Pkt.	Type	Order No.	Pcs./ Pkt.
		Type	Order No.	Pcs./ Pkt.						
Plug-in miniature power relays, with power contacts										
	① 4.5 V DC	REL-MR- 4,5DC/21	2961367	10						
	② 12 V DC	REL-MR- 12DC/21	2961150	10	REL-MR- 12DC/21/MS	2909641	10			
	③ 18 V DC	REL-MR- 18DC/21	2961383	10						
	④ 24 V DC	REL-MR- 24DC/21	2961105	10	REL-MR- 24DC/21/MS	2909642	10			
	⑤ 60 V DC	REL-MR- 60DC/21	2961118	10	REL-MR- 60DC/21/MS	2909643	10			
	⑥ 110 V DC									
Plug-in miniature power relays, with multi-layer gold contacts										
	① 4.5 V DC	REL-MR 4,5DC/21AU	2961370	10						
	② 12 V DC	REL-MR- 12DC/21AU	2961163	10	REL-MR- 12DC/21AU/MS	2909644	10			
	③ 18 V DC	REL-MR- 18DC/21AU	2961493	10						
	④ 24 V DC	REL-MR- 24DC/21AU	2961121	10	REL-MR- 24DC/21AU/MS	2909645	10			
	⑤ 60 V DC	REL-MR- 60DC/21AU	2961134	10	REL-MR- 60DC/21AU/MS	2909647	10			
	⑥ 110 V DC									



2-PDT relay,
2 x 8 A, maximum



1-N/O relay for
high inrush currents,
max. 130 A peak



1-PDT relay for
high continuous currents,
max. 16 A

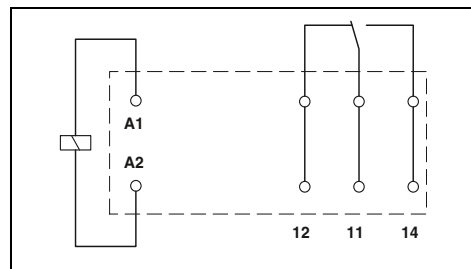
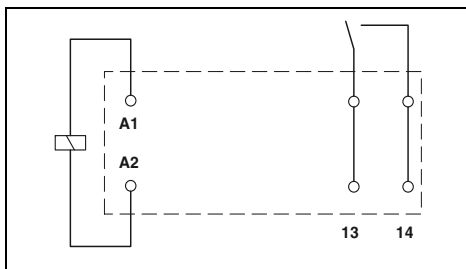
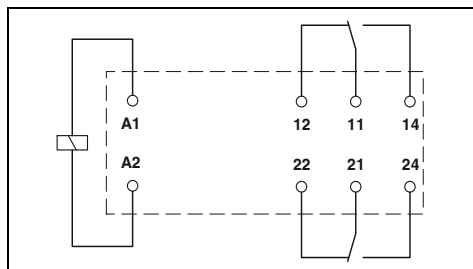

Technical data			
②	④	⑤	⑥
see diagram			
33	17	8.2	4.1
7	7	7	7
3	3	3	3
2 PDT		2 PDT	
AgNi		AgNi, hard gold-plated	
250 V AC/DC		30 V AC / 36 V DC	
5 V (at 10 mA)		100 mV (at 10 mA)	
8 A		50 mA	
25 A (20 ms)		50 mA	
10 mA (At 5 V)		1 mA (at 24 V)	
190 W		1.2 W	
85 W		-	
60 W		-	
44 W		-	
60 W		-	
2000 VA		-	
5 kV AC (50 Hz, 1 min.)			
-40 °C ... 85 °C			
100% operating factor			
3 x 10 ⁷ cycles			
IEC 60664 , EN 50178 , EN 61810-1			
any / Can be aligned without spacing (> 70 °C ≥ 2.5 mm)			
12.7 mm / 29 mm / 15.7 mm			

Technical data	
④	
see diagram	
17	
8	
3	
1 N/O contact	
AgSnO	
250 V AC/DC	
12 V (at 100 mA)	
16 A	
80 A (20 ms) /	
130 A (peak, at capacitive load, 230 V AC, 24 μF)	
100 mA (at 12 V DC)	
384 W	
58 W	
48 W	
50 W	
80 W	
4000 VA	
5 kV AC (50 Hz, 1 min.)	
-40 °C ... 85 °C	
100% operating factor	
3 x 10 ⁷ cycles	
IEC 60664 , EN 50178	
any / Can be aligned without spacing (> 70 °C ≥ 2.5 mm)	
12.7 mm / 29 mm / 15.7 mm	

Technical data			
②	④	⑤	⑥
see diagram			
33	17	8.2	4.1
7	7	7	7
3	3	3	3
1 PDT		1 PDT	
AgNi		AgNi	
250 V AC/DC		250 V AC/DC	
12 V (at 10 mA)		12 V (at 10 mA)	
16 A		16 A	
50 A (20 ms)		50 A (20 ms)	
10 mA (at 12 V)		10 mA (at 12 V)	
384 W		384 W	
58 W		58 W	
48 W		48 W	
50 W		50 W	
80 W		80 W	
4000 VA		4000 VA	
5 kV AC (50 Hz, 1 min.)			
-40 °C ... 85 °C			
100% operating factor			
3 x 10 ⁷ cycles			
IEC 60664 , EN 50178 , EN 61810-1			
any / Can be aligned without spacing (> 70 °C ≥ 2.5 mm)			
12.7 mm / 29 mm / 15.7 mm			

Ordering data		
Type	Order No.	Pcs./ Pkt.
REL-MR- 12DC/21-21	2961257	10
REL-MR- 24DC/21-21	2961192	10
REL-MR- 60DC/21-21	2961273	10
REL-MR-110DC/21-21	2961202	10
REL-MR- 12DC/21-21AU	2961299	10
REL-MR- 24DC/21-21AU	2961215	10
REL-MR- 60DC/21-21AU	2961286	10
REL-MR-110DC/21-21AU	2961228	10

Ordering data		
Type	Order No.	Pcs./ Pkt.
REL-MR- 24DC/11C	2961341	10

Ordering data		
Type	Order No.	Pcs./ Pkt.
REL-MR- 12DC/21HC	2961309	10
REL-MR- 24DC/21HC	2961312	10
REL-MR- 60DC/21HC	2961325	10
REL-MR-110DC/21HC	2961338	10

Relay modules

Highly compact relay modules - PLC-INTERFACE

Plug-in solid-state relays

Plug-in solid-state relays are suitable for both PLC-INTERFACE and RIF-0 and RIF-1 relay base.

The advantages:

- Switching current of up to 5 A
- RT III-proof (wash-proof)
- Vibration and shock-resistant
- Wear-free and long-lasting
- Zero voltage switch at AC output
- Can be soldered on PCB



Solid-state relay,
DC output max. 3 A



Solid-state relay,
DC output max. 100 mA

Notes:
For dimensional drawings and perforations for assembly, see page 399
When mounting relays on a DIN rail base or PCB, data may be limited, especially with regard to the limiting continuous current and/or ambient temperature range. See "General" section in "Basics of relay technology" on page 286.

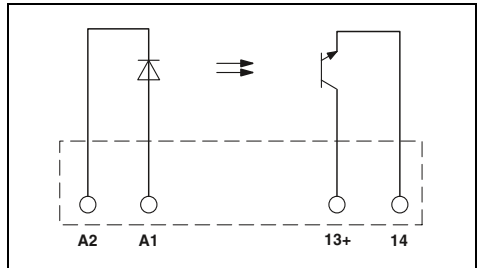
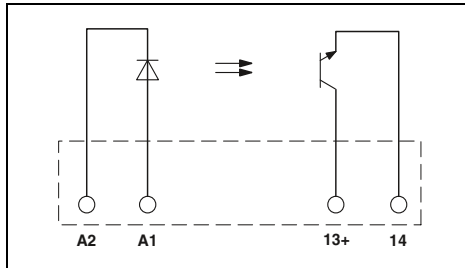

Input data	
Permissible range (with reference to U_N)	
Switching level	1 signal ("H") [V DC] \geq 0 signal ("L") [V DC] \leq
Typical input current at U_N	[mA]
Typical switch-on time at U_N	[μ s]
Typical switch-off time at U_N	[μ s]
Transmission frequency f_{limit}	[Hz]
Output data	
Max. switching voltage	33 V DC
Minimum switching voltage	3 V DC
Limiting continuous current	3 A (see derating curve)
Minimum load current	-
Maximum switch-on current	15 A (10 ms)
Leakage current in off state	-
Phase angle (cos ϕ)	-
Output circuit	2-wire, floating
Max. load value	-
Output protection	Reverse polarity protection, surge protection
Voltage drop at maximum limiting continuous current	\leq 150 mV
General data	
Rated surge voltage	Basic insulation
Test voltage input/output	2.5 kV (50 Hz, 1 min.)
Ambient temperature (operation)	-25 °C ... 60 °C
Nominal operating mode	100% operating factor
Standards/regulations	IEC 60664 , EN 50178
Degree of pollution/surge voltage category	2 / III
Mounting position/mounting	any / In rows with zero spacing
Dimensions	5 mm / 28 mm / 15 mm

Technical data		
①	②	③
0.8 - 1.2	0.8 - 1.2	0.8 - 1.2
2.5	16	35
0.8	10	20
9	7	3
20	20	40
300	300	500
300	300	300

Technical data		
①	②	③
0.8 - 1.2	0.8 - 1.2	0.9 - 1.1
2.5	16	52
0.8	10	40
4	7	3
20	20	50
300	300	800
300	300	100

Description	Input voltage U_N
Plug-in solid-state relays	
Solid-state power relays	① 5 V DC
Solid-state power relays	② 24 V DC
Solid-state power relays	③ 60 V DC
Plug-in solid-state relays	
Solid-state input relays	① 5 V DC
Solid-state input relays	② 24 V DC
Solid-state input relays	③ 60 V DC

Ordering data		
Type	Order No.	Pcs./Pkt.
OPT-5DC/ 24DC/ 2	2967989	10
OPT-24DC/ 24DC/ 2	2966595	10
OPT-60DC/ 24DC/ 2	2966605	10

Ordering data		
Type	Order No.	Pcs./Pkt.
OPT-5DC/ 48DC/100	2967992	10
OPT-24DC/ 48DC/100	2966618	10
OPT-60DC/ 48DC/100	2966621	10



Solid-state relay,
DC output max. 5 A

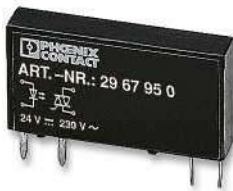

Solid-state relay,
AC output max. 750 mA



Solid-state relay,
AC output max. 2 A

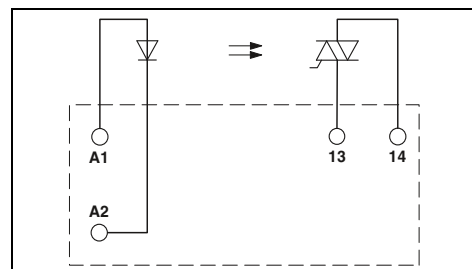
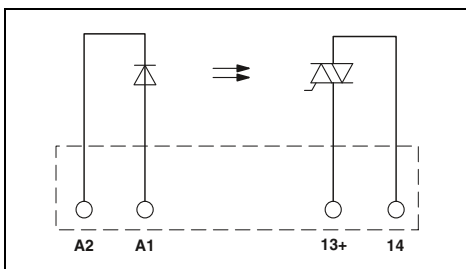
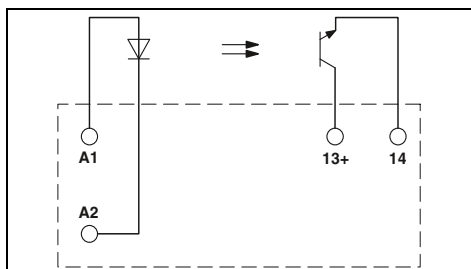

Technical data

Technical data

Technical data

①	②	③
0.8 - 1.2	0.8 - 1.2	0.9 - 1.1
2.5	16	35
0.8	10	20
9	7	3
10	20	25
400	400	400
300	300	300

②	③
0.8 - 1.2	0.9 - 1.1
10	50
5	15
3	3
6000	9000
500	700
10	10

①	②	③
0.8 - 1.2	0.8 - 1.2	0.9 - 1.1
3	18	40
1	8.4	20
15	7	2.6
10000	10000	10000
10000	10000	10000
10	10	10

33 V DC
3 V DC
5 A (see derating curve)
-
15 A (10 ms)
-
-
2-wire, floating
-
Reverse polarity protection, surge protection
≤ 200 mV

253 V AC
24 V AC
0.75 A (see derating curve)
10 mA
30 A (10 ms)
< 1 mA
0.5
2-conductor floating, zero voltage switch
4.5 A²s
RCV circuit
< 1 V

253 V AC
24 V AC
2 A (see derating curve)
25 mA
30 A (10 ms)
< 1 mA
-
2-conductor floating, zero voltage switch
4 A²s (tp = 10 ms, at 25 °C)
Surge protection
≤ 1 V

Basic insulation
2.5 kV (50 Hz, 1 min.)
-25 °C ... 60 °C
100% operating factor
IEC 60664, EN 50178
2 / III

Basic insulation
2.5 kV (50 Hz, 1 min.)
-25 °C ... 60 °C
100% operating factor
IEC 60664, EN 50178
2 / III

Basic insulation
2.5 kV (50 Hz, 1 min.)
-25 °C ... 60 °C
100% operating factor
IEC 60664
2 / III

any / In rows with zero spacing
12.7 mm / 29 mm / 15.7 mm

any / In rows with zero spacing
5 mm / 28 mm / 15 mm

any / See derating curve
12.7 mm / 29 mm / 15.7 mm

Ordering data

Ordering data

Ordering data

Type	Order No.	Pcs./Pkt.
OPT-5DC/ 24DC/ 5	2982113	10
OPT-24DC/ 24DC/ 5	2982100	10
OPT-60DC/ 24DC/ 5	2982126	10

Type	Order No.	Pcs./Pkt.
OPT-24DC/230AC/ 1	2967950	10
OPT-60DC/230AC/ 1	2967963	10

Type	Order No.	Pcs./Pkt.
OPT-5DC/230AC/ 2	2982168	10
OPT-24DC/230AC/ 2	2982171	10
OPT-60DC/230AC/ 2	2982184	10

Operating voltage ranges for PLC-INTERFACE, 6.2 mm versions, equipped with relay

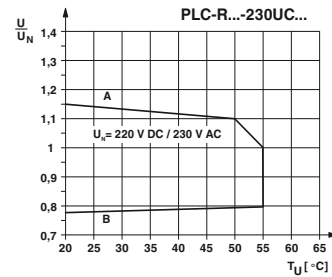
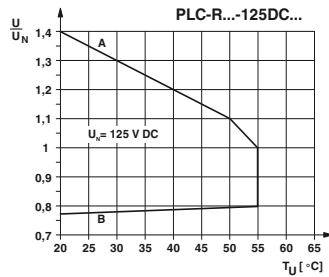
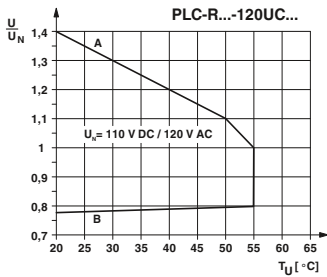
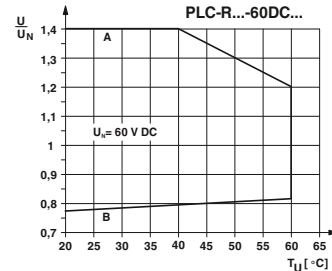
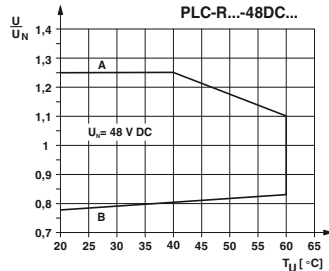
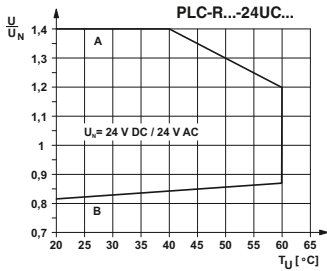
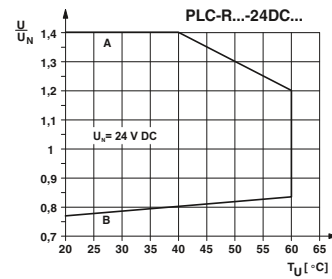
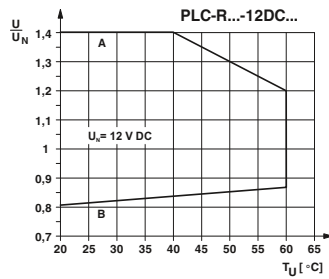

Operating voltage ranges for PLC-INTERFACE, 14 mm versions, equipped with relay

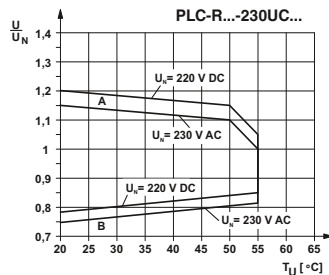
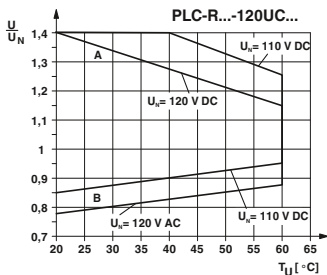
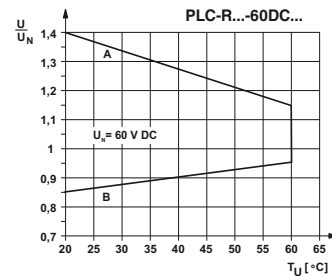
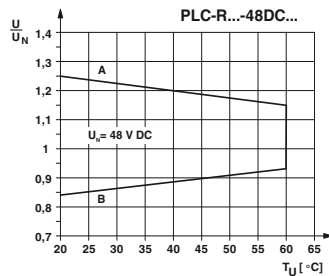
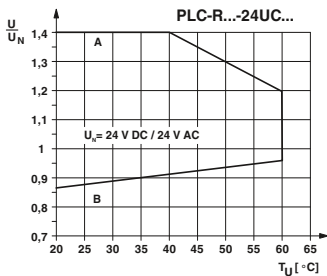
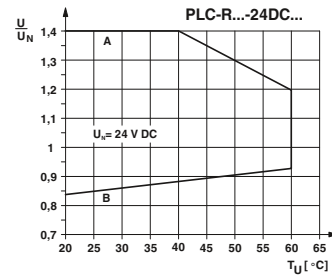
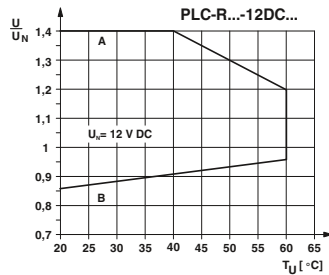

General conditions:

Direct alignment in the block, all devices 100% operating time, horizontal or vertical mounting.

Curve A

Maximum permissible continuous voltage U_{max} with limiting continuous current on the contact side (see relevant technical data).

Curve B

Minimum permitted pick-up voltage U_{op} after pre-excitation¹⁾ (see relevant technical data).

¹⁾ **Pre-excitation:** relay has been operated in a thermally steady state at the ambient temperature T_A with nominal voltage U_N and limiting continuous current on the contact side (see relevant technical data) (warm coil). After being switched off for a short time, the relay must reliably pick up again at U_{op} . The U_{op} values for cold coils ($T_{coil} = T_A = 20^\circ C$) indicated by other manufacturers yield better values, but are not practical.

Relay modules

Tables, diagrams, dimensional drawings

Plug-in 1 and 2-PDT relays

REL-MR...21

Permissible input voltage range for REL-MR...21

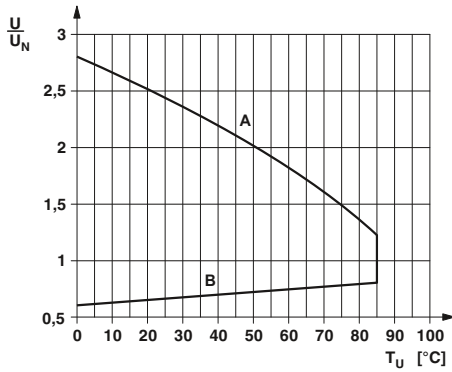

General conditions:

Direct alignment in the block, all devices 100% operating time, horizontal or vertical mounting.

Curve A

Maximum permissible continuous voltage U_{max} with limiting continuous current on the contact side (see relevant technical data).

Curve B

Minimum permitted pick-up voltage U_{op} after pre-excitation¹⁾ (see relevant technical data).

^{1) Pre-excitation:} relay has been operated in a thermally steady state at the ambient temperature T_A with nominal voltage U_N and limiting continuous current on the contact side (see relevant technical data) (warm coil). After being switched off for a short time, the relay must reliably pick up again at U_{op} . The U_{op} values for cold coils ($T_{coil} = T_A = 20^\circ\text{C}$) indicated by other manufacturers yield better values, but are not practical.

REL-MR...21-21

Permissible input voltage range for REL-MR...21-21, REL-MR-24DC/11C, REL-MR...21HC

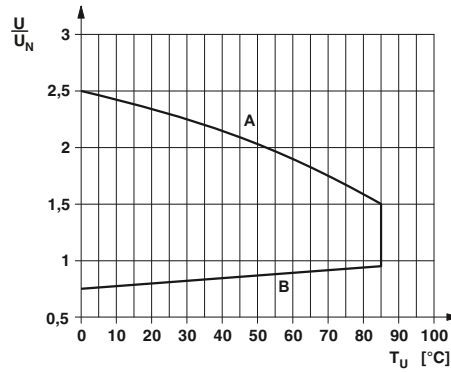

5 mm overall width

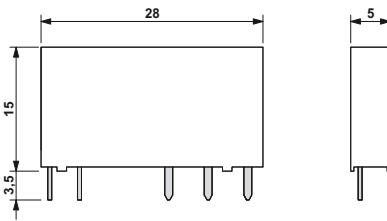

12.7 mm overall width

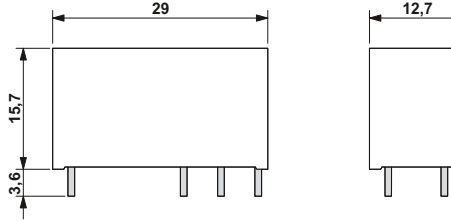

Perforations for assembly: view of the connections

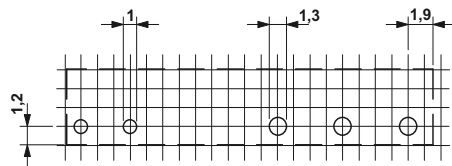

Pitch division: 1.25 mm and 1.27 mm

Perforations for assembly: view of the connections

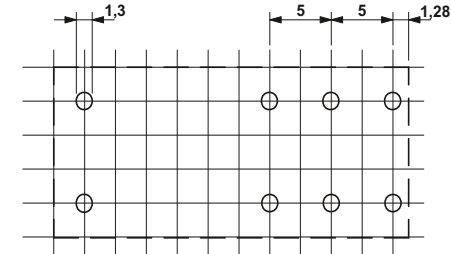

Pitch division: 2.5 mm

Plug-in solid-state relays

OPT...DC/24DC/2
OPT...DC/230AC/1

Derating curve for OPT...DC/24DC/2 and PLC-OS.../24DC/2 solid-state relays

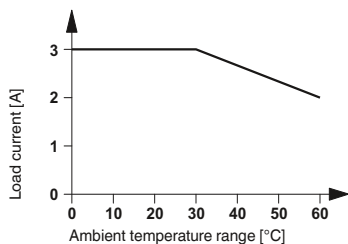

OPT...DC/24DC/5
OPT...DC/230AC/2

Derating curve for OPT...DC/24DC/5 and PLC-OS.../24DC/5/ACT solid-state relays

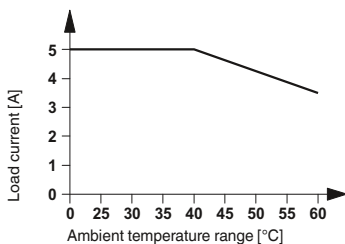

Derating curve for OPT...DC/230AC/1 and PLC-OS.../230AC/1 solid-state relays

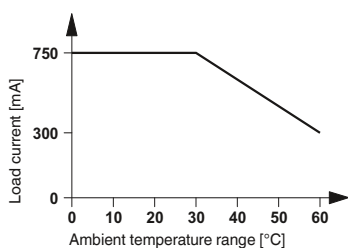

Derating curve for OPT...DC/230AC/2 and PLC-OS.../230AC/2/ACT solid-state relays

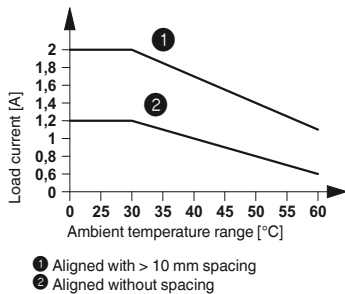

5 mm overall width

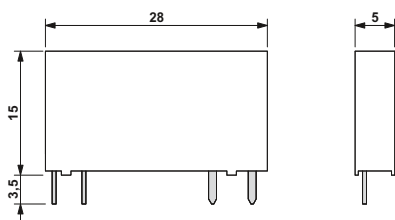

12.7 mm overall width

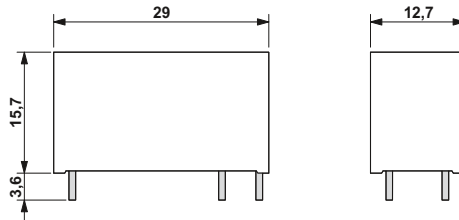

Relay modules

Tables, diagrams, dimensional drawings

Electrical interrupting rating for PLC-INTERFACE

Electrical interrupting rating for PLC...21 with 1-PDT relay

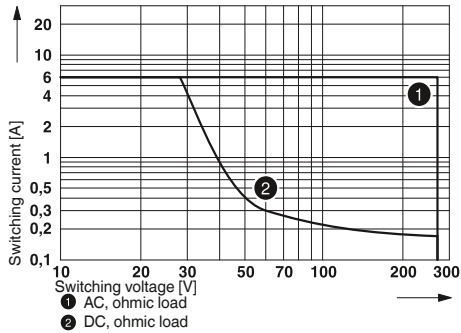

PLC-INTERFACE for railway applications

Electrical service life for PLC-RSP...UC/21RW

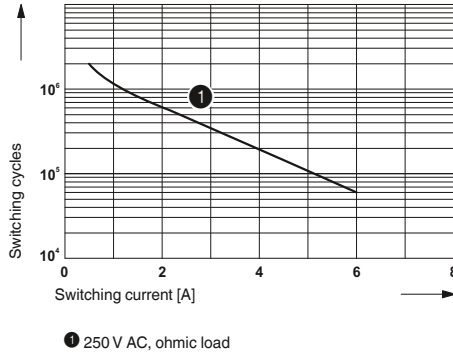

Electrical interrupting rating for PLC...21-21 with 2-PDT relay

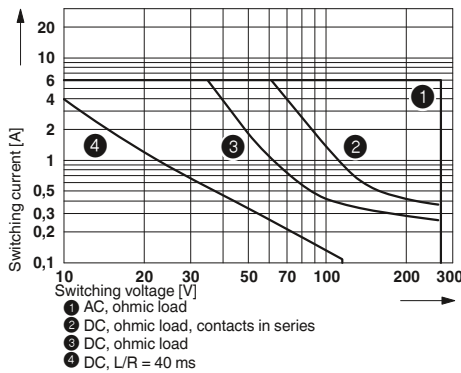

Electrical service life for PLC-RSP...UC/21-21/RW

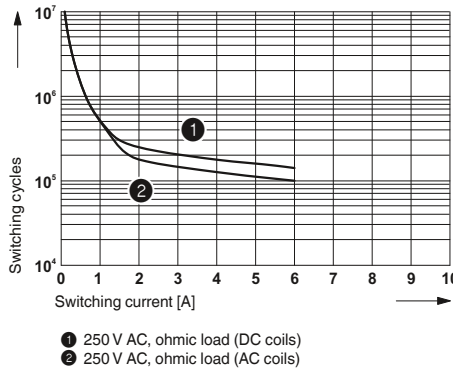

Electrical interrupting rating for PLC...1IC/ACT for high inrush currents

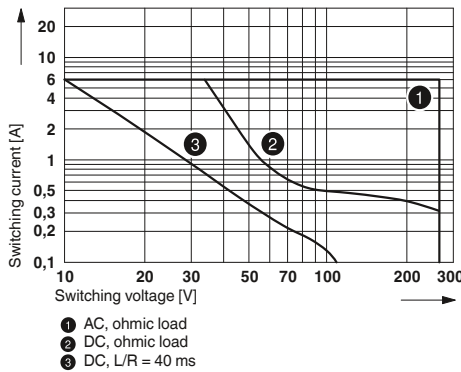

Electrical service life for PLC-RSP...UC/21HC/RW

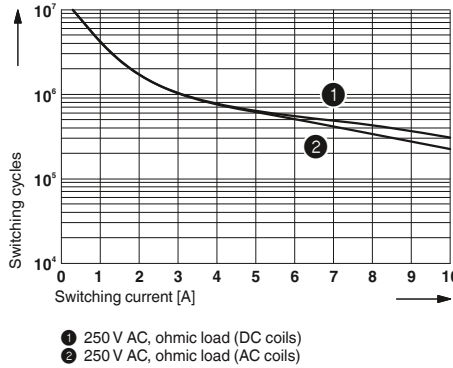

Electrical interrupting rating for PLC...21HC for high continuous currents

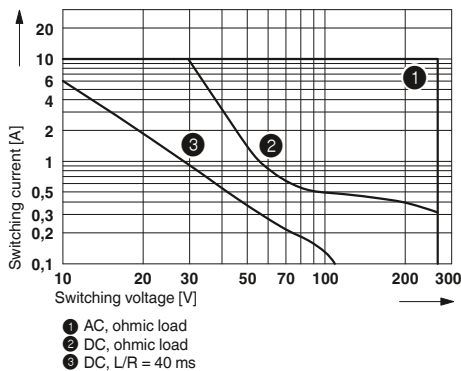

EMG-OV solid-state power relays

Derating curve for EMG 17-OV...48DC/2

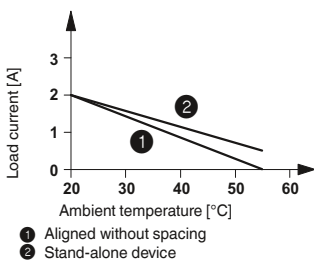

ST-OV 4-24DC/24DC...PRO power circuit breaker solid-state relays with signal logic

Derating curve for ST-OV 4-24DC/24DC...PRO

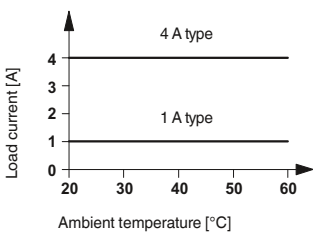

Time/current characteristic curve, 1 A version

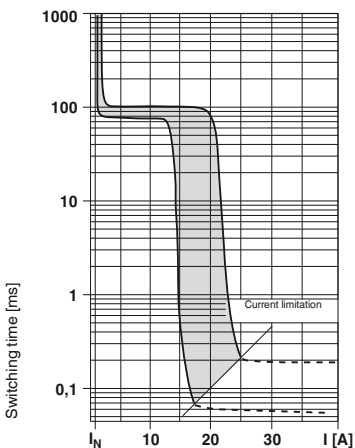

Time/current characteristic curve, 4 A version

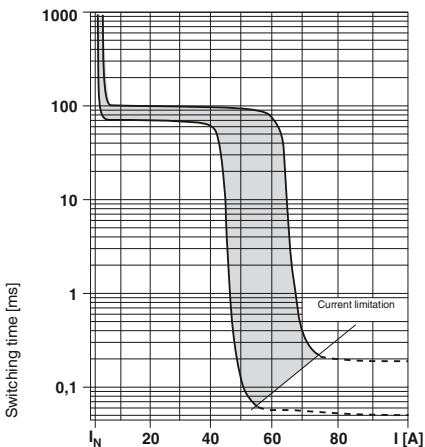

State diagram

Operating state	Switching level Input	LED display yellow LED	LED display red LED	Signal contact/CONTROL
Not activated	L	L	L	
Normal operation	H	H	L	
Overload/short circuit	H	H	H	
Open circuit	L	L	H	

UEGM-OE/AV logic pulse expansion block

Time diagrams for UEGM-OE/AV-24DC/24DC/100

Scenario 1: Input pulse $t_i < t_{O\ set}$

Operating voltage present

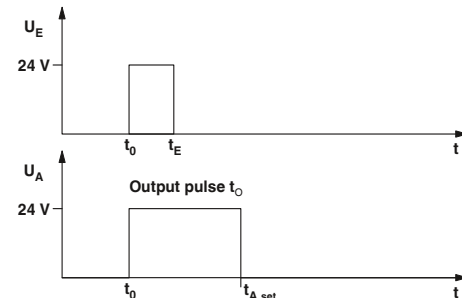

Scenario 2: input pulse $t_i \geq t_{O\ set}$; $t_i = t_{O\ set}$

Operating voltage present

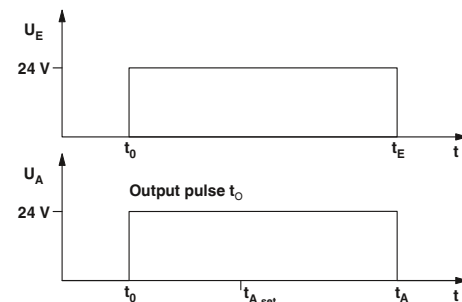

Table of adjustable output pulse lengths

	DIP switches ¹⁾							
	S1	S2	S3	S4	S5	S6	S7	S8
Length of output pulses [ms] (when switch is set to "ON")	10	-	-	-	-	-	-	-
	-	20	-	-	-	-	-	-
	-	-	50	-	-	-	-	-
	-	-	-	100	-	-	-	-
	-	-	-	-	200	-	-	-
	-	-	-	-	-	500	-	-
	-	-	-	-	-	-	1000	-
	-	-	-	-	-	-	-	1500

¹⁾ If no switch is actuated, the output voltage is not defined.

If the input pulse is longer than the set time, the output is switched off almost simultaneously with the input.

Intermediate values can be obtained by combining several DIP switches according to the following formula:

$$T_{tot} = \frac{1}{\frac{1}{t_1} + \frac{1}{t_2} + \dots + \frac{1}{t_n}}$$

Relay modules

Highly compact relay modules - PLC-INTERFACE

PLC-INTERFACE with two integrated relays

Relay module with two permanently soldered-in power relays

The advantages:

- 100% more channel density than the conventional 6.2 mm relay
- Two switching channels in a 6.2 mm housing
- Screw and Push-in connection technology

Notes:
Type of insulating housing: Polyamide PBT, non-reinforced, color: green.
Marking systems and mounting material See Catalog 3



Relay module with two integrated, independent relays up to 3.5 A for high channel density

ERC

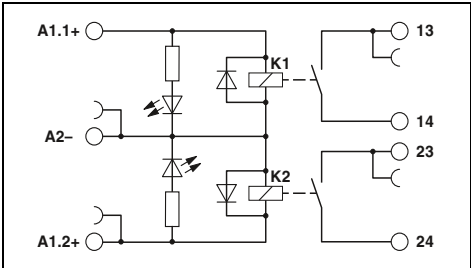

Technical data

Input data	①
Typical input current at U_N	7 [mA]
Response/release time at U_N	4 / 6 [ms]
Input circuit DC	Yellow LED, reverse polarity protection, freewheeling diode
Output data	
Contact material	AgNi
Max. switching voltage	250 V AC / 30 V DC
Minimum switching voltage	24 V AC/DC
Limiting continuous current	3.5 A
Minimum switching current	5 mA
General data	
Test voltage input/output	3 kV AC (50 Hz, 1 min.)
Test voltage output/output	3 kV AC (50 Hz, 1 min.)
Ambient temperature (operation)	-20 °C ... 60 °C
Mechanical service life	2 x 10 ⁷ cycles
Standards/regulations	IEC 60664 , EN 50178
Connection data solid/stranded/AWG	0.14 - 2.5 mm ² / 0.14 - 2.5 mm ² / 26 - 14
Dimensions	6.2 mm / 80 mm / 86 mm
EMC note	Class A product, see page 605

Ordering data

Description	Input voltage U_N	Type	Order No.	Pcs./Pkt.
PLC-INTERFACE, with screw connection				
①	24 V DC	PLC-2RSC-24DC/ 1	2987309	10
PLC-INTERFACE, with Push-in connection				
①	24 V DC	PLC-2RPT-24DC/1	2901639	10

Application example for PLC-2RS...24DC/1

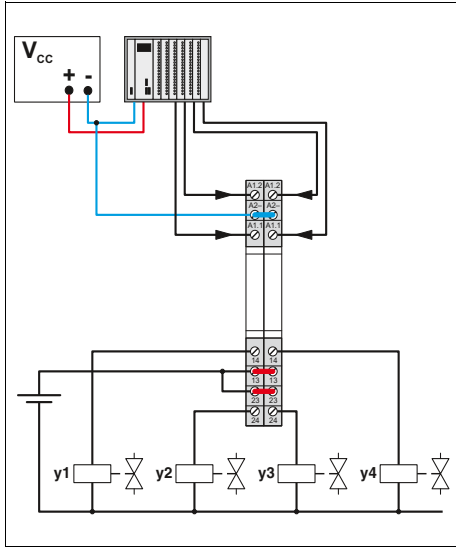

Operating voltage range

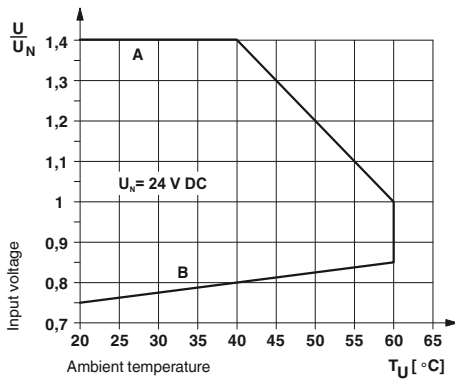

Interrupting rating

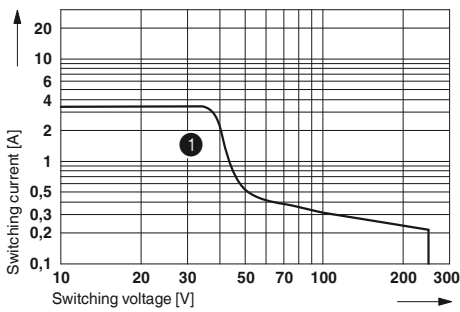

① DC, ohmic load

Relay modules

Highly compact relay modules - PLC-INTERFACE

PLC-INTERFACE with manual switch and relay

Relay module with manual switch and integrated power relay for manual, zero, and automatic functions

The advantages are:

- Maximum switching current 6 A
- Only 6.2 mm wide
- Floating confirmation contact
- Safe isolation according to DIN EN 50178 between coil and contact
- Screw and Push-in connection technology

Notes:
Type of housing: Polyester PBT, non-reinforced, color: green.
Marking systems and mounting material See Catalog 3
For the protection of input and output, inductive loads must be dampened with an effective protection circuit.
The PLC-ATP partition plate is to be used in the following cases: always at the start and end of a PLC terminal strip, for voltages greater than 250 V (L1, L2, L3) between the same terminal points of neighboring modules (potential bridging then takes place with FBST 8-PLC... or FBST 500...) and with safe isolation between neighboring modules.
Module height: PLC-...-S/H = 90 mm; PLC-...-S/L: = 86 mm
PLC...H - manual operation PLC...L - operation using screwdriver



Relay module with manual switch and integrated relay

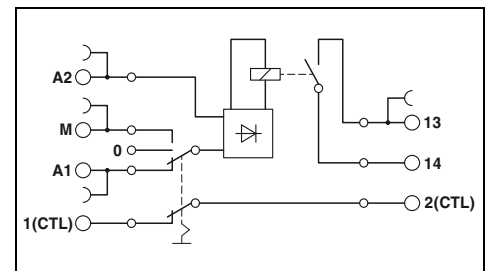

Application example for PLC-RS...24UC/1/S...

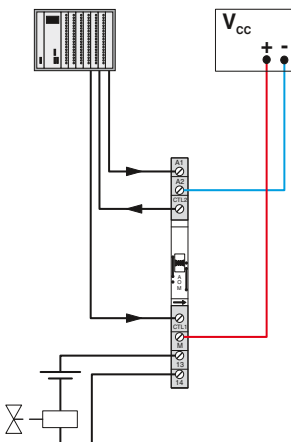

Permissible input voltage range for PLC-RS...24UC/1/S...

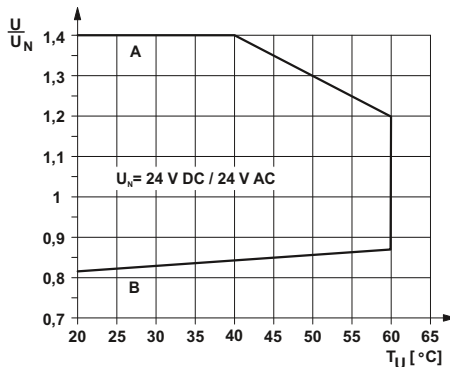

Curve A
Maximum continuous voltage when limiting continuous current = 6 A

Curve B
Minimum pick-up voltage for pre-excitation with U_N and limiting continuous current = 6 A

Technical data

Input data	①	②
Typical input current at U _N	11	11
Response/release time at U _N	6 / 15	6 / 15
Input circuit AC/DC	Yellow LED, Bridge rectifier	
Output data		
Contact material	AgSnO	
Max. switching voltage	250 V AC/DC	
Minimum switching voltage	5 V (at 100 mA)	
Limiting continuous current	6 A	
Maximum switch-on current	on request	
Minimum switching current	10 mA (at 12 V)	
Feedback		
Operating mode "Automatic" floating	max. 30 V AC/DC / 50 mA min. 2 V AC/DC / 1 mA	
General data		
Rated insulation voltage	250 V AC	
Rated surge voltage	6 kV	
Ambient temperature (operation)	-20 °C ... 60 °C	
Standards/regulations	IEC 60664, EN 50178	
Degree of pollution/surge voltage category	2 / III	
Connection data solid/stranded/AWG	0.14 - 2.5 mm ² / 0.14 - 2.5 mm ² / 26 - 14	
Dimensions	W / H / D	
EMC note	Class A product, see page 605	

Ordering data

Description	Input voltage U _N	Type	Order No.	Pcs./ Pkt.
PLC-INTERFACE, with screw connection	①	PLC-RSC- 24UC/ 1/S/H	2982236	10
	②	PLC-RSC- 24UC/ 1/S/L	2834876	10
PLC-INTERFACE, with Push-in connection	①	PLC-RPT- 24UC/ 1/S/H	2900328	10
	②	PLC-RPT- 24UC/ 1/S/L	2900327	10

PLC-INTERFACE with manual switch without relay

Switching module without relay for manual, zero, and automatic functions

The advantages:

- Only 6.2 mm wide
- Floating confirmation contact
- Screw connection technology

Notes:
Type of housing: Polyester PBT, non-reinforced, color: green.
Marking systems and mounting material See Catalog 3
For the protection of input and output, inductive loads must be dampened with an effective protection circuit.
The PLC-ATP partition plate is to be used in the following cases: always at the start and end of a PLC terminal strip, for voltages greater than 250 V (L1, L2, L3) between the same terminal points of neighboring modules (potential bridging then takes place with FBST 8-PLC... or FBST 500...) and with safe isolation between neighboring modules.
Module height: PLC-...-S/H = 90 mm; PLC-...-S/L = 86 mm
PLC...H - manual operation PLC...L - operation using screwdriver



Module with manual switch without relay

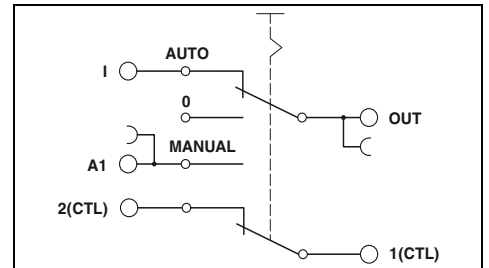

Technical data

Max. switching voltage
Minimum switching voltage
Maximum switch-on current
Minimum switching current
Switching cycles, max.

72 V DC
2 V DC
50 mA
1 mA
100 (At 72 V DC / 50 mA) /
10000 (at 12 V DC / 100 mA)

Feedback
Operating mode "Automatic" floating

≤ 72 V DC / 50 mA

General data

Rated insulation voltage
Rated surge voltage
Ambient temperature (operation)
Standards/regulations
Degree of pollution/surge voltage category
Connection data solid/stranded/AWG
Dimensions

85 V AC
0.5 kV / basic insulation
-20 °C ... 60 °C
IEC 60664 , EN 50178
2 / III
0.14 - 2.5 mm² / 0.14 - 2.5 mm² / 26 - 14
6.2 mm / 80 mm / 90 mm

W / H / D

Ordering data

Description
PLC-INTERFACE, with screw connection

Type	Order No.	Pcs./ Pkt.
PLC-SC-S/H	2980733	10
PLC-SC-S/L	2980775	10

Application example for PLC-S...S...

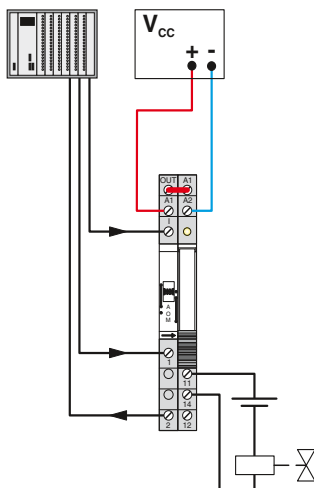

Relay modules

Highly compact relay modules - PLC-INTERFACE

PLC-INTERFACE with an integrated solid-state relay

The slim 6.2 mm PLC housing with integrated electronics in various versions offers the following advantages:

- Option of bridging adjacent modules
- Status display
- Protection circuits in input and output
- Wear-resistant and bounce-free switching
- Integrated protection circuit
- DC outputs of up to 300 V DC/1 A or up to 24 V DC/10 A
- Electronic PDT output of up to 48 V DC/500 mA
- Screw and Push-in connection technology

Notes:
Type of housing: Polyester PBT, non-reinforced, color: green.
Marking systems and mounting material See Catalog 3
For the protection of input and output, inductive loads must be dampened with an effective protection circuit.
The PLC-ATP partition plate is to be used in the following cases: always at the start and end of a PLC terminal strip, for voltages greater than 250 V (L1, L2, L3) between the same terminal points of neighboring modules (potential bridging then takes place with FBST 8-PLC... or FBST 500...) and with safe isolation between neighboring modules.
The housings of the following modules are open on one side: - PLC-O...-300DC/1 - PLC-O...-24DC/24DC/10/R



Solid-state relay module, DC output max. 300 V DC/1 A

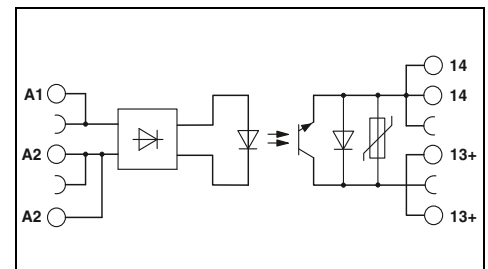

Input data	
Permissible range (with reference to U_N)	
Switching level (with reference to U_N)	1 signal ("H") 0 signal ("L")
Typical input current at U_N	[mA]
Transmission frequency f_{limit}	[Hz]
Alarm output	
Operating range	- / -
Output data	
Maximum/minimum switching voltage	300 V DC / 12 V DC
Limiting continuous current	1 A (see derating curve)
Voltage drop at maximum limiting continuous current	< 500 mV
General data	
Rated insulation voltage	300 V
Rated surge voltage	4 kV / basic insulation
Ambient temperature (operation)	-25 °C ... 60 °C
Standards/regulations	IEC 60664, EN 50178
Connection data solid/stranded/AWG	0.14 - 2.5 mm ² / 0.14 - 2.5 mm ² / 26 - 14
Dimensions	W / H / D 6.2 mm / 80 mm / 86 mm
EMC note	Class A product, see page 605

Technical data							
①	②	③	④	⑤	⑥	⑦	⑧
0.8 - 1.2	0.8 - 1.2	0.8 - 1.2	0.8 - 1.2	0.8 - 1.2	0.8 - 1.2	0.8 - 1.1	0.8 - 1.1
≥ 0.8	≥ 0.8	≥ 0.8	≥ 0.8	≥ 0.8	≥ 0.8	≥ 0.8	≥ 0.8
≤ 0.4	≤ 0.4	≤ 0.4	≤ 0.4	≤ 0.4	≤ 0.4	≤ 0.4	≤ 0.4
15	6	8	5	5	3	5.6	8.4
50	50	50	50	50	50	10	10

Description	Input voltage U_N
PLC-INTERFACE, with screw connection	
①	5 V DC
②	12 V DC
③	24 V DC
④	60 V DC
⑤	110 V DC
⑥	220 V DC
⑦	120 V AC
⑧	230 V AC
PLC-INTERFACE, with Push-in connection	
①	5 V DC
②	12 V DC
③	24 V DC
④	60 V DC
⑤	110 V DC
⑥	220 V DC
⑦	120 V AC
⑧	230 V AC

Ordering data			
Type	Order No.	Pcs./Pkt.	
PLC-OSC- 5DC/300DC/ 1	2980652	10	
PLC-OSC- 12DC/300DC/ 1	2980665	10	
PLC-OSC- 24DC/300DC/ 1	2980678	10	
PLC-OSC- 60DC/300DC/ 1	2980681	10	
PLC-OSC-110DC/300DC/ 1	2980694	10	
PLC-OSC-220DC/300DC/ 1	2980704	10	
PLC-OSC-120AC/300DC/ 1	2980717	10	
PLC-OSC-230AC/300DC/ 1	2980720	10	
PLC-OPT- 5DC/300DC/1	2900381	10	
PLC-OPT- 12DC/300DC/1	2900382	10	
PLC-OPT- 24DC/300DC/1	2900383	10	
PLC-OPT- 60DC/300DC/1	2900384	10	
PLC-OPT-110DC/300DC/1	2900385	10	
PLC-OPT-220DC/300DC/1	2900387	10	
PLC-OPT-120AC/300DC/1	2900388	10	
PLC-OPT-230AC/300DC/1	2900389	10	

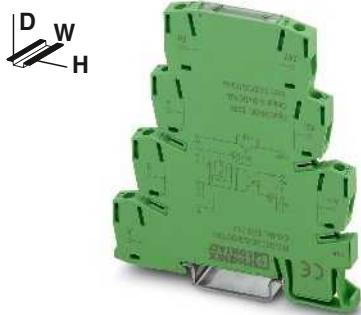

Solid-state relay module, short-circuit-proof DC output max. 10 A, with feedback

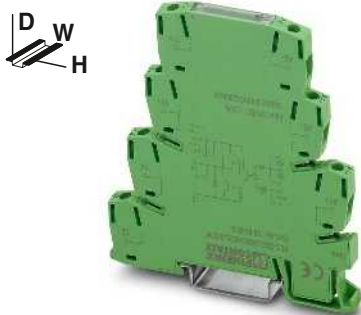

Solid-state relay module, DC output max. 500 mA, with electronic changeover contact

Derating curve for PLC...300DC/1

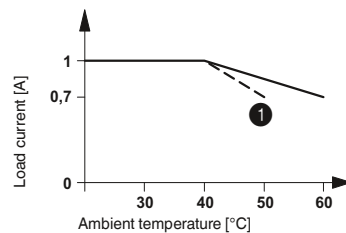

① For input voltages of 220 V DC and 230 V AC

Derating curve for PLC-...24DC/24DC/10/R

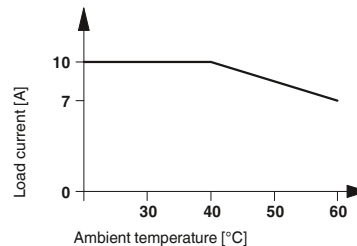

Derating curve for PLC...24DC/48DC/500/W

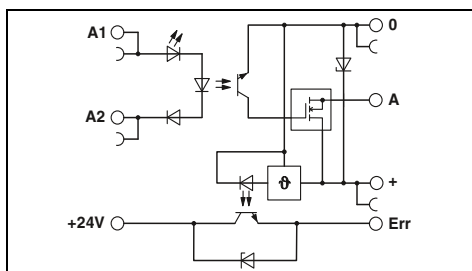
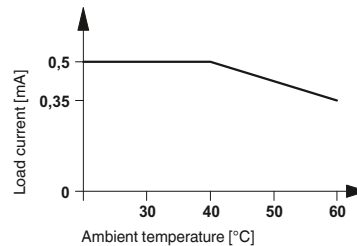

Technical data

- ③
- 0.8 -
- 1.2
- ≥ 0.8
- ≤ 0.4
- 3
- 100

3 V DC ... 33 V DC (High active) / 100 mA

33 V DC / 5 V DC
10 A (see derating curve)
≤ 50 mV

300 V
4 kV / basic insulation
-25 °C ... 60 °C
IEC 60664 , EN 50178
0.14 - 2.5 mm² / 0.14 - 2.5 mm² / 26 - 14
6.2 mm / 80 mm / 86 mm
Class A product, see page 605

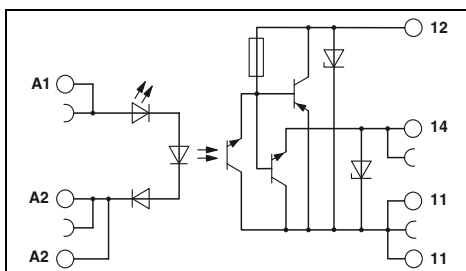

Technical data

- ③
- 0.8 -
- 1.2
- ≥ 0.8
- ≤ 0.4
- 3
- 1000

- / -

48 V DC / 3 V DC
500 mA (see derating curve)
< 1.2 V

300 V
4 kV / basic insulation
-25 °C ... 60 °C
IEC 60664 , EN 50178
0.14 - 2.5 mm² / 0.14 - 2.5 mm² / 26 - 14
6.2 mm / 80 mm / 86 mm
Class A product, see page 605

Ordering data

Type	Order No.	Pcs./ Pkt.
PLC-OSC- 24DC/ 24DC/ 10/R	2982702	10
PLC-OPT- 24DC/ 24DC/10/R	2900398	10

Ordering data

Type	Order No.	Pcs./ Pkt.
PLC-OSC- 24DC/ 48DC/500/W	2980636	10
PLC-OPT- 24DC/ 48DC/500/W	2900378	10

Relay modules

Highly compact relay modules - PLC-INTERFACE

PLC-INTERFACE with an integrated solid-state relay

- 6.2 mm narrow solid-state relay for switching AC loads
- Status display
- Protection circuits in input and output
- Wear-free
- Switching capacity up to 230 V AC/2.4 A
- Screw and Push-in connection technology



Solid-state relay module with additional floating terminal point, AC output max. 2.4 A

ERC

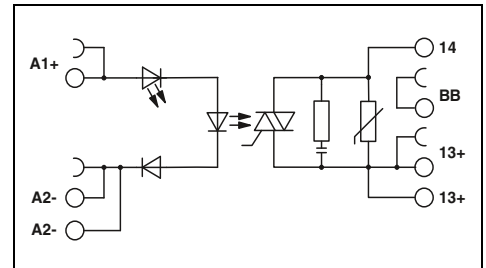

Technical data

Input data		①
Rated actuating voltage range with reference to U_c		0.8 - 1.2
Rated actuating current I_c	[mA]	8
Switching level (with reference to U_c)	1 signal ("H")	> 0.8
	0 signal ("L")	< 0.4
Typical switch-on time at U_N	[ms]	10
Typical switch-off time at U_N	[ms]	10
Transmission frequency f_{limit}	[Hz]	10
Input circuit DC		Yellow LED, reverse polarity protection, surge protection
Output data		
Max. switching voltage		253 V AC
Minimum switching voltage		24 V AC
Maximum switch-on current		250 A (20 ms)
Minimum/maximum switching current		10 mA / 2.4 A (see derating)
Output protection		RCV circuit
Voltage drop at maximum limiting continuous current		< 1 V
Leakage current in off state		< 1 mA
Max. load value		340 A ² s (tp = 10 ms, at 25 °C)
General data		
Rated insulation voltage		260 V AC
Rated surge voltage		4 kV
Insulation		Basic insulation
Ambient temperature (operation)		-25 °C ... 60 °C
Standards/regulations		DIN EN 50178
Degree of pollution/surge voltage category		2 / III
Connection data solid/stranded/AWG		0.14 - 2.5 mm ² / 0.14 - 2.5 mm ² / 26 - 14
Dimensions	W / H / D	6.2 mm / 80 mm / 86 mm
EMC note		Class A product, see page 605

Ordering data

Description	Rated actuating voltage U_c	Type	Order No.	Pcs./ Pkt.
PLC-INTERFACE, with screw connection	① 24 V DC	PLC-OSC- 24DC/230AC/2.4/ACT	2904631	10
PLC-INTERFACE, with Push-in connection	① 24 V DC	PLC-OPT- 24DC/230AC/2.4/ACT	2904632	10

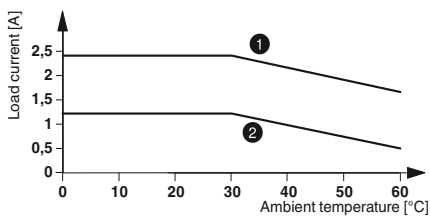

① = aligned with > 20 mm spacing
② = aligned without spacing

Load current as a function of the ambient temperature
Operating time: 100% operating factor

PLC-INTERFACE with hybrid solid-state relay

The solid-state relay, combined with a mechanical relay, offers the following advantages:

- Higher electrical service life
- Lower power dissipation
- Option of bridging adjacent modules
- Status display
- Protection circuits in input and output
- Switching capacity up to 230 V AC/10 A
- Screw and Push-in connection technology

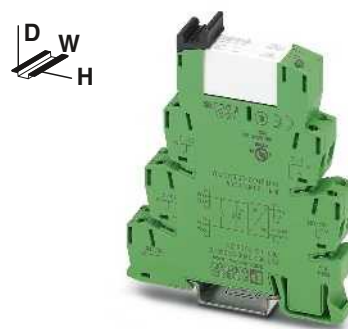

Hybrid solid-state relay, AC output max. 10 A and bypass relay

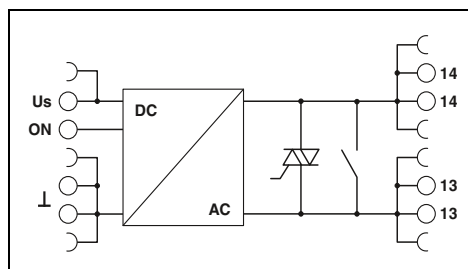

Technical data

Input data		①
Rated control supply voltage U_s	[V DC]	24
Rated control supply voltage range with reference to U_s		0.8 - 1.2
Rated control supply current I_s		14 mA (Input low, output low) 19 mA (Input high, output high)
Rated actuation voltage U_c ON	[V DC]	24
Rated actuating voltage range with reference to U_c		0.8 - 1.2
Rated actuating current I_c	[mA]	6.8
Input circuit DC		Yellow LED, reverse polarity protection, surge protection
Output data		
Max. switching voltage		253 V AC
Minimum switching voltage		24 V AC
Minimum/maximum switching current		100 mA / 10 A (see derating curve)
Output protection		RCV circuit
Leakage current in off state		< 1 mA
Max. load value		350 A ² s (tp = 10 ms, at 25 °C)
General data		
Rated insulation voltage		260 V AC
Rated surge voltage		6 kV
Insulation		safe isolation
Ambient temperature (operation)		-25 °C ... 60 °C
Standards/regulations		DIN EN 50178
Degree of pollution/surge voltage category		2 / III
Connection data solid/stranded/AWG		0.14 - 2.5 mm ² / 0.14 - 2.5 mm ² / 26 - 14
Dimensions	W / H / D	14 mm / 80 mm / 94 mm
EMC note		Class A product, see page 605

Ordering data

Description	Rated actuating voltage U_c	Type	Order No.	Pcs./Pkt.
PLC-INTERFACE, with screw connection				
①	24 V DC	PLC-HSC-24DC/230AC/10	2905214	1
PLC-INTERFACE, with Push-in connection				
①	24 V DC	PLC-HPT-24DC/230AC/10	2905215	1

Relay modules

Highly compact relay modules - PLC-INTERFACE

PLC-INTERFACE

Solid-state relays up to 100 kHz

A solid-state relay for the safe acquisition of short pulses.

- Status display
- Bridging options
- Limit frequency of up to 100 kHz
- Push-pull stage on output side
- Features a capacitor on the input side for interference suppression

Notes:
Type of insulating housing: Polyamide PBT, non-reinforced, color: green.
Marking systems and mounting material See Catalog 3



**Solid-state relay module,
DC output,
transmission frequency of 100 kHz**

ERC

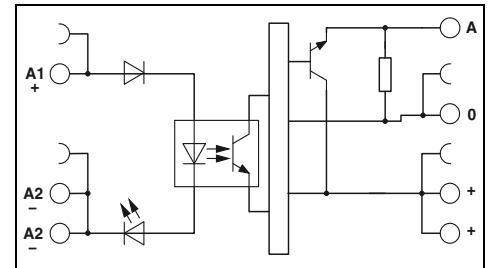

Technical data

Input data		①	②
Permissible range (with reference to U_N)		0.8 - 1.2	0.8 - 1.2
Switching level with reference to U_N		1 signal ("H") > 0.8	> 0.8
		0 signal ("L") < 0.4	< 0.4
Typical input current at U_N		[mA]	7 6
Typical switch-on time at U_N		[μs]	1.5 1.5
Typical switch-off time at U_N		[μs]	2 2
Transmission frequency f_{limit}		[kHz]	100 100
Input protection:		Yellow LED, reverse polarity protection, surge protection	
Output data			
Operating voltage range		4 V DC ... 30 V DC	
Limiting continuous current		50 mA	
Quiescent current		4.3 mA	
Residual voltage drop at "H"		< 0.5 V	
Output circuit		3-conductor, ground-referenced	
Output protection		Reverse polarity protection, surge protection	
General data			
Test voltage input/output		2.5 kV _{rms} (50 Hz, 1 min.)	
Ambient temperature (operation)		-20 °C ... 60 °C	
Standards/regulations		DIN EN 50178	
Degree of pollution/surge voltage category		2 / II	
Connection data solid/stranded/AWG		0.14 - 2.5 mm ² / 0.14 - 2.5 mm ² / 26 - 14	
Dimensions		W / H / D 6.2 mm / 80 mm / 86 mm	
EMC note		Class A product, see page 605	

Ordering data

Description	Input voltage U_N	Type	Order No.	Pcs./ Pkt.
Input solid-state relay with screw connection	① 5 V DC	PLC-OSC- 5DC/ 24DC/100KHZ	2902963	1
	② 24 V DC	PLC-OSC- 24DC/ 24DC/100KHZ	2902964	1
Input solid-state relay with Push-in connection	① 5 V DC	PLC-OPT- 5DC/ 24DC/100KHZ	2902969	1
	② 24 V DC	PLC-OPT- 24DC/24DC/100KHZ	2902970	1

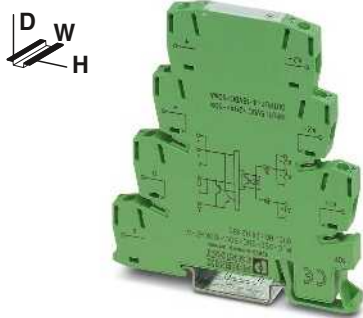

Solid-state relay module,
DC push-pull output,
transmission frequency of 100 kHz

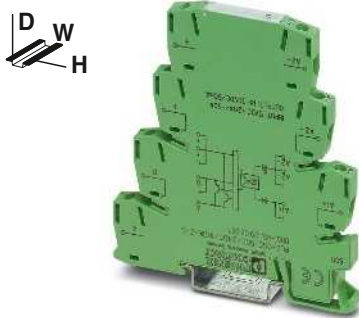

Solid-state relay module,
DC push-pull output,
transmission frequency of 100 kHz

ERC

ERC

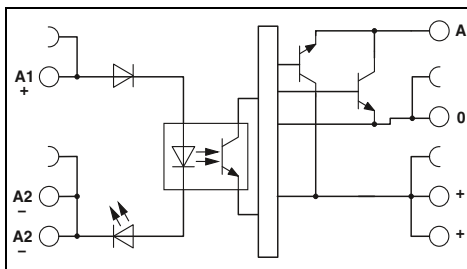
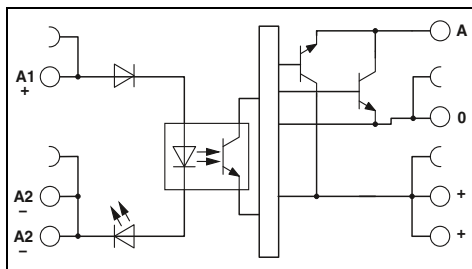

Technical data

Technical data

①	②
0.5 - 1.2	0.8 - 1.2
> 0.5	> 0.8
< 0.3	< 0.4
8	8
1	1
2	2
100	100

Yellow LED, reverse polarity protection, surge protection

①	②
0.5 - 1.2	0.8 - 1.2
> 0.5	> 0.8
< 0.3	< 0.4
8	8
1	1
2	2
100	100

Yellow LED, reverse polarity protection, surge protection

4 V DC ... 18 V DC
50 mA
8.5 mA
< 1.2 V

3-conductor push-pull, ground referenced
Reverse polarity protection, surge protection

14 V DC ... 30 V DC
50 mA
15 mA
< 2.2 V

3-conductor push-pull, ground referenced
Reverse polarity protection, surge protection

2.5 kV_{rms} (50 Hz, 1 min.)
-20 °C ... 60 °C
DIN EN 50178
2 / II
0.14 - 2.5 mm² / 0.14 - 2.5 mm² / 26 - 14
6.2 mm / 80 mm / 86 mm
Class A product, see page 605

2.5 kV_{rms} (50 Hz, 1 min.)
-20 °C ... 60 °C
DIN EN 50178
2 / II
0.14 - 2.5 mm² / 0.14 - 2.5 mm² / 26 - 14
6.2 mm / 80 mm / 86 mm
Class A product, see page 605

Ordering data

Ordering data

Type	Order No.	Pcs./ Pkt.
PLC-OSC- 5DC/ 5DC/100KHZ-G	2902965	1
PLC-OSC- 24DC/ 5DC/100KHZ-G	2902966	1
PLC-OPT- 5DC/ 5DC/100KHZ-G	2902971	1
PLC-OPT- 24DC/ 5DC/100KHZ-G	2902972	1

Type	Order No.	Pcs./ Pkt.
PLC-OSC- 5DC/ 24DC/100KHZ-G	2902967	1
PLC-OSC- 24DC/ 24DC/100KHZ-G	2902968	1
PLC-OPT- 5DC/24DC/100KHZ-G	2902973	1
PLC-OPT- 24DC/24DC/100KHZ-G	2902974	1

Relay modules

Highly compact relay modules - PLC-INTERFACE

PLC-INTERFACE for the TTL signal at input

The PLC-BS...TTL/1 basic terminal block is controlled with a TTL (5 V) input signal. It is equipped with either a mechanical relay or a solid-state relay. The basic terminal block equipped with a robust miniature relay offers the following advantages:

- Overall width of just 6.2 mm
- Bridging options
- Status display
- RTIII degree of protection
- Safe isolation in accordance with EN 50178 (VDE 0160)
- 4 kV_{rms} electrical isolation between coil and contact
- Screw and Push-in connection technology

Notes:
Type of housing: Polyester PBT, non-reinforced, color: green.
Marking systems and mounting material See Catalog 3



1-N/O basic terminal block for assembly with relay for TTL (5 V)

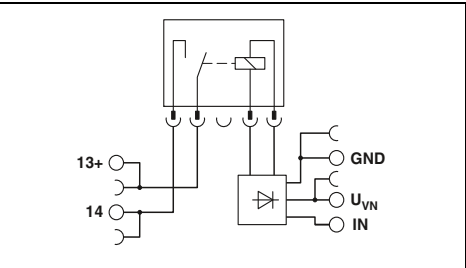

Technical data

Input data	REL-MR-4,5DC/21 AU	REL-MR-4,5DC/21
Rated control supply voltage U_{VN}	5 V DC	5 V DC
Rated control supply voltage range with reference to U_{VN}	0.9 ... 1.2	0.9 ... 1.2
Rated control supply current I_{VN}	41 mA	41 mA
Rated actuating voltage U_c (IN)	5 V DC (TTL)	5 V DC (TTL)
Rated actuating voltage range with reference to U_c	0.9 ... 1.2	0.9 ... 1.2
Rated actuating current I_c	2.5 mA	2.5 mA
Typical response time at U_c	4.5 ms	4.5 ms
Typical release time at U_c	3.5 ms	3.5 ms
Input circuit	Yellow LED, reverse polarity protection, surge protection	Yellow LED, reverse polarity protection, surge protection
Output data with:		
Contact type	Single contact, 1 N/O contact	Single contact, 1 N/O contact
Contact material	AgSnO, hard gold-plated	AgSnO
Max. switching voltage	30 V AC / 36 V DC	250 V AC/DC
Minimum switching voltage	100 mV (at 10 mA)	5 V (at 100 mA)
Limiting continuous current	50 mA	6 A
Maximum switch-on current	50 mA	on request
Minimum switching current	1 mA (at 24 V)	10 mA (at 12 V)
General data		
Rated insulation voltage	250 V	250 V
Rated surge voltage/insulation	6 kV	6 kV
Ambient temperature (operation)	-20 °C ... 60 °C	-20 °C ... 60 °C
Mechanical service life	2 x 10 ⁷ cycles	2 x 10 ⁷ cycles
Air clearances and creepage distances between the power circuits	IEC 60664, EN 50178	IEC 60664, EN 50178
Degree of pollution / Overvoltage category	2 / III	2 / III
Mounting position / Assembly	any / in rows with zero spacing	any / in rows with zero spacing
Connection data solid/stranded/AWG	0.14 - 2.5 mm ² / 0.14 - 2.5 mm ² / 26 - 14	0.14 - 2.5 mm ² / 0.14 - 2.5 mm ² / 26 - 14
Dimensions	6.2 mm / 80 mm / 94 mm	6.2 mm / 80 mm / 94 mm
EMC note	Class A product, see page 605	Class A product, see page 605

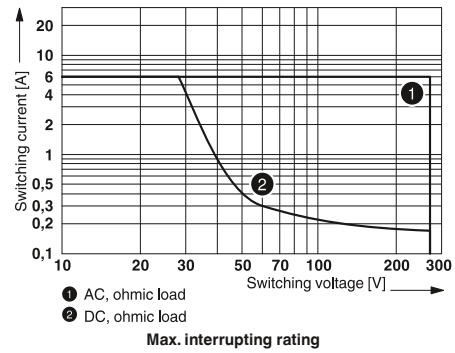

Description
PLC-INTERFACE with screw connection with Push-in connection
Plug-in miniature power relays, with multi-layer gold contacts

Ordering data

Type	Order No.	Pcs./ Pkt.
PLC-BSC-TTL/1	2982689	10
PLC-BPT-TTL/1	2900458	10

Accessories

REL-MR 4,5DC/21AU	2961370	10
REL-MR- 4,5DC/21	2961367	10

PLC-INTERFACE for the TTL signal at input

The PLC-BS...TTL/1 basic terminal block is controlled with a TTL (5 V) input signal. It is equipped with either a mechanical relay or a solid-state relay. The basic terminal block equipped with a solid-state relay offers the following advantages:

- Overall width of just 6.2 mm
- Bridging options
- Status display
- IP67-protected solid-state relay electronic unit
- Switching capacity of up to 24 V DC/3 A
- Alternative input or power solid-state relay
- Wear-free and bounce-free
- Integrated protective circuit
- 2.5 kV_{rms} electrical isolation between input and output
- Screw and Push-in connection technology

Notes:
Type of housing: Polyester PBT, non-reinforced, color: green.
Marking systems and mounting material See Catalog 3
For derating curves see page 399



Basic terminal block for assembly with solid-state relay for TTL (5 V)

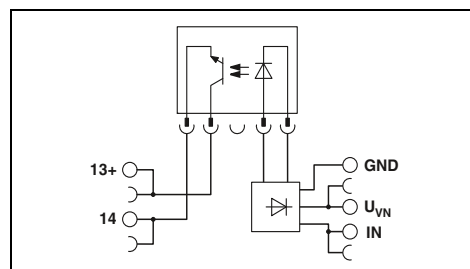

Technical data

Input data		5 V DC
Rated control supply voltage U_{VN}	Rated control supply voltage range with reference to U_{VN}	0.9 ... 1.2
Rated control supply current I_{VN}	Rated actuating voltage U_c (IN)	11.5 mA
Rated actuating voltage U_c (IN)	Switching level 1 signal ("H") (TTL signal)	5 V DC (TTL)
Switching level 1 signal ("H") (TTL signal)	Switching level 0 signal ("L") (TTL signal)	> 2 V DC
Switching level 0 signal ("L") (TTL signal)	Rated actuating current I_c	< 0.8 V DC
Rated actuating current I_c	Typical response time/switch-on time at U_c	2.5 mA
Typical response time/switch-on time at U_c	Typical switch-off time at U_c	35 μ s
Typical switch-off time at U_c	Input circuit	320 μ s
Input circuit		Yellow LED, reverse polarity protection, surge protection
Output data with:		
Max. switching voltage	OPT-5DC/48DC/100	OPT-5DC/24DC/2
Minimum switching voltage	48 V DC	33 V DC
Limiting continuous current	3 V DC	3 V DC
Output protection	100 mA	3 A
	Reverse polarity protection, Surge protection	Reverse polarity protection, Surge protection
	< 1 V	< 200 mV
Voltage drop at limiting continuous current		
General data		
Rated insulation voltage	250 V	
Rated surge voltage/insulation	6 kV/Basic isolation	
Ambient temperature (operation)	-20 °C ... 60 °C	
Air clearances and creepage distances between the power circuits	IEC 60664, EN 50178	
Degree of pollution / Overvoltage category	2 / III	
Connection data solid/stranded/AWG	0.14 - 2.5 mm ² / 0.14 - 2.5 mm ² / 26 - 14	
Dimensions	6.2 mm / 80 mm / 94 mm	
EMC note	Class A product, see page 605	

Ordering data

Description	Type	Order No.	Pcs./ Pkt.
PLC-INTERFACE			
with screw connection	PLC-BSC-TTL/1	2982689	10
with Push-in connection	PLC-BPT-TTL/1	2900458	10

Accessories

Plug-in solid-state relays			
Solid-state input relays	OPT-5DC/ 48DC/100	2967992	10
Solid-state power relays	OPT-5DC/ 24DC/ 2	2967989	10

Relay modules

Highly compact relay modules - PLC-INTERFACE

PLC-INTERFACE for the TTL signal at output

The PLC-OS...24DC/TTL with a built-in solid-state relay can be used for fast and wear-free switching of TTL (5 V) signals.

- The module offers the following advantages:
- Switching capacity TTL (5 V), fan out = 1
 - Overall width of just 6.2 mm
 - Bridging options
 - Status display
 - Integrated protective circuit
 - Screw and Push-in connection technology

Notes:
Type of housing: Polyester PBT, non-reinforced, color: green.
Marking systems and mounting material See Catalog 3



Input solid state relays with TTL (5 V) output

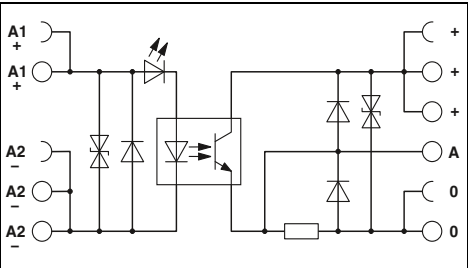

Technical data

Input data										
Rated actuating voltage U_C	24 V DC									
Rated actuating voltage range with reference to U_C	0.8 ... 1.2									
Switching level 1 signal ("H")	> 0.8									
Switching level 0 signal ("L")	< 0.4									
Rated actuating current I_C	3.4 mA									
Typical switch-on time at U_C	35 μ s									
Typical switch-off time at U_C	35 μ s									
Transmission frequency f_{limit}	1 kHz									
Input circuit DC	Yellow LED, reverse polarity protection, surge protection									
Output data with:										
Rated control supply voltage U_S	5 V DC									
Rated control supply voltage range with reference to U_S	0.9 ... 1.2									
Limiting continuous current	A TTL load (Fan out = 1)/50 mA for switching mode									
Output protection	Reverse polarity protection, surge protection									
Voltage drop at maximum limiting continuous current	< 80 mV									
General data										
Rated insulation voltage	250 V DC									
Rated surge voltage/insulation	4 kV / basic insulation									
Ambient temperature (operation)	-25 °C ... 60 °C									
Air clearances and creepage distances between the power circuits	IEC 60664 , EN 50178									
Degree of pollution/surge voltage category	2 / III									
Connection data solid/stranded/AWG	0.14 - 2.5 mm ² / 0.14 - 2.5 mm ² / 26 - 14									
Dimensions	6.2 mm / 80 mm / 86 mm									
EMC note	Class A product, see page 605									
Description										
PLC-INTERFACE										
with screw connection	PLC-OSC- 24DC/TTL									
with Push-in connection	PLC-OPT- 24DC/TTL									
	Ordering data									
	<table border="1"> <thead> <tr> <th>Type</th> <th>Order No.</th> <th>Pcs./Pkt.</th> </tr> </thead> <tbody> <tr> <td>PLC-OSC- 24DC/TTL</td> <td>2982728</td> <td>10</td> </tr> <tr> <td>PLC-OPT- 24DC/TTL</td> <td>2900363</td> <td>10</td> </tr> </tbody> </table>	Type	Order No.	Pcs./Pkt.	PLC-OSC- 24DC/TTL	2982728	10	PLC-OPT- 24DC/TTL	2900363	10
Type	Order No.	Pcs./Pkt.								
PLC-OSC- 24DC/TTL	2982728	10								
PLC-OPT- 24DC/TTL	2900363	10								

Derating curve for PLC-OSP...24DC/3RW

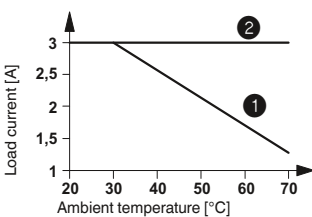

- ① Aligned without spacing
- ② Aligned with ≥ 20 mm spacing

Derating curve for PLC-OSP...110DC/3RW

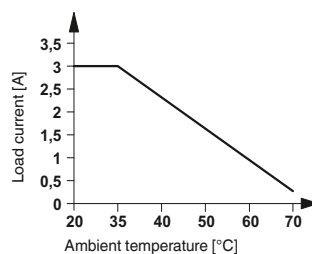

PLC-INTERFACE with solid-state relays for railway applications

The PLC-OSP...RW interface modules are suitable for use according to DIN EN 50155 (VDE 0115 Part 200) "Railway applications - Electronic equipment used on rolling stock".

- The advantages:
- Temperature range -25°C to +70°C
 - Input voltage range 0.7-1.25 x U_N
 - Shock resistance in acc. with DIN 50155 (requirements in acc. with EN 61373).
 - Spring cage and Push-in connection technology



Solid-state relay module, DC output max. 3 A



Solid-state relay module, DC output max. 110 V DC/3 A

Notes:
Type of housing: Polyester PBT, non-reinforced, color: green.
Marking systems and mounting material See Catalog 3
For derating curves see page 414

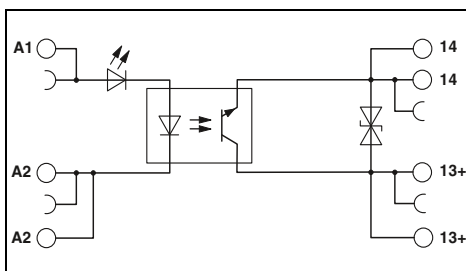

Technical data

Input data		
Permissible range (with reference to U _N)	①	⑥
	0.7 - 1.25	0.7 - 1.25
Switching level (with reference to U _N)	1 signal ("H") ≥ 0.6	≥ 0.6
	0 signal ("L") ≤ 0.3	≤ 0.3
Typical input current at U _N	[mA]	8.5
Typical switch-on time at U _N	[ms]	0.04
Typical switch-off time at U _N	[ms]	0.2
Transmission frequency f _{limit}	[Hz]	300
Input circuit DC		Yellow LED, reverse polarity protection

Output data	
Max. switching voltage	33 V DC
Minimum switching voltage	3 V DC
Limiting continuous current	3 A (see derating curve)
Output protection	Reverse polarity protection, surge protection
Voltage drop at maximum limiting continuous current	< 200 mV

General data	
Rated insulation voltage	250 V
Rated surge voltage	4 kV / basic insulation
Ambient temperature (operation)	-25 °C ... 70 °C
Standards/regulations	IEC 60664 , EN 50178
Degree of pollution/surge voltage category	2 / III

Connection data solid/stranded/AWG	0.14 - 2.5 mm ² / 0.14 - 2.5 mm ² / 26 - 14
Dimensions	W / H / D 6.2 mm / 80 mm / 86 mm
EMC note	Class A product, see page 605

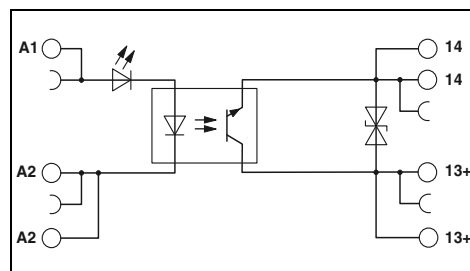

Technical data

Input data					
Permissible range (with reference to U _N)	①	②	③	④	⑤
	0.7 - 1.25	0.7 - 1.25	0.7 - 1.25	0.7 - 1.25	0.7 - 1.25
Switching level (with reference to U _N)	1 signal ("H") ≥ 0.6	≥ 0.6	≥ 0.6	≥ 0.6	≥ 0.6
	0 signal ("L") ≤ 0.3	≤ 0.3	≤ 0.3	≤ 0.3	≤ 0.3
Typical input current at U _N	[mA]	12	12	5.5	5.5
Typical switch-on time at U _N	[ms]	0.4	0.4	0.04	0.04
Typical switch-off time at U _N	[ms]	0.2	0.1	0.2	0.2
Transmission frequency f _{limit}	[Hz]	50	50	300	300
Input circuit DC		Yellow LED, reverse polarity protection, surge protection			

Output data	
Max. switching voltage	140 V DC
Minimum switching voltage	12 V DC
Limiting continuous current	3 A (see derating curve)
Output protection	Reverse polarity protection, surge protection
Voltage drop at maximum limiting continuous current	< 150 mV

General data	
Rated insulation voltage	160 V DC
Rated surge voltage	4 kV / basic insulation
Ambient temperature (operation)	-25 °C ... 70 °C
Standards/regulations	IEC 60664 , EN 50178
Degree of pollution/surge voltage category	2 / III

Connection data solid/stranded/AWG	0.14 - 2.5 mm ² / 0.14 - 2.5 mm ² / 26 - 14
Dimensions	W / H / D 6.2 mm / 80 mm / 86 mm
EMC note	Class A product, see page 605

Ordering data

Type	Order No.	Pcs./ Pkt.
PLC-OSP- 24DC/ 24DC/ 3RW	2980513	10
PLC-OSP-110DC/ 24DC/ 3RW	2980526	10
PLC-OPT- 24DC/ 24DC/3RW	2900379	10
PLC-OPT-110DC/ 24DC/3RW	2900380	10

Ordering data

Type	Order No.	Pcs./ Pkt.
PLC-OSP- 24DC/110DC/ 3RW	2982511	10
PLC-OSP- 36DC/110DC/ 3RW	2982524	10
PLC-OSP- 48DC/110DC/ 3RW	2982537	10
PLC-OSP- 72DC/110DC/ 3RW	2982540	10
PLC-OSP- 96DC/110DC/ 3RW	2982553	10
PLC-OSP-110DC/110DC/ 3RW	2982566	10
PLC-OPT- 24DC/110DC/3RW	2900391	10
PLC-OPT- 36DC/110DC/3RW	2900392	10
PLC-OPT- 48DC/110DC/3RW	2900393	10
PLC-OPT- 72DC/110DC/3RW	2900394	10
PLC-OPT- 96DC/110DC/3RW	2900395	10
PLC-OPT-110DC/110DC/3RW	2900396	10

Description	Input voltage U _N
PLC-INTERFACE, with spring-cage connection	
①	24 V DC
②	36 V DC
③	48 V DC
④	72 V DC
⑤	96 V DC
⑥	110 V DC
PLC-INTERFACE, with Push-in connection	
①	24 V DC
②	36 V DC
③	48 V DC
④	72 V DC
⑤	96 V DC
⑥	110 V DC

Relay modules

Highly compact relay modules - PLC-INTERFACE

PLC-INTERFACE for railway applications

Relay modules with extended input voltage and temperature range, specifically for use in railway applications

The advantages:

- Temperature range -25°C to +70°C
- Input voltage range 0.7 to 1.25 × U_N
- Vibration and shock resistance according to EN 50155
- Safe isolation according to DIN EN 50178 between coil and contact
- Push-in connection technology

Notes:
Type of insulating housing: Polyamide PBT, non-reinforced, color: green.
Marking systems and mounting material See Catalog 3
The PLC-ATP partition plate must be installed for voltages larger than 250 V (L1, L2, L3) between identical terminal blocks in adjacent modules. Potential bridging is then carried out with FBST 8-PLC... or FBST 500....
If the specified maximum values for multi-layer contact relays are exceeded, the gold plating is destroyed. The maximum values of the power contact relay are then valid. This can result in a shorter service life than with a pure power contact.



Basic terminal block for assembly with 1-PDT relay up to 6 A

RAI EAC DNV GL

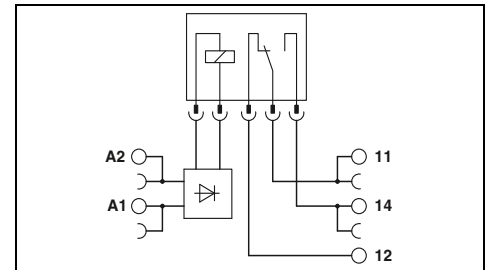

Permissible input voltage range for PLC-BSP-24DC/21RW (with REL-MR-18DC/21... relay)

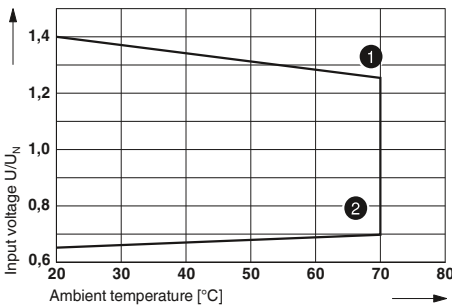

- 1 Maximum continuous voltage when limiting continuous current = 3 A
- 2 Minimum pick-up voltage for pre-excitation with U_N and limiting continuous current = 3 A

Electrical interrupting rating for PLC...21 with 1-PDT relay

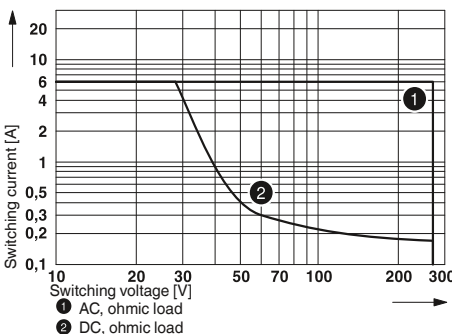

- 1 AC, ohmic load
- 2 DC, ohmic load

Input data	
Nominal input voltage U _N	
Permissible range (with reference to U _N)	
Typical input current at U _N	
Typical response time at U _N	
Typical release time at U _N	
Input circuit	
Output data with:	
Contact type	
Contact material	
Max. switching voltage	
Minimum switching voltage	
Limiting continuous current	
Maximum switch-on current	
Minimum switching current	
General data	
Test voltage input/output	
Ambient temperature (operation)	
Mechanical service life	
Standards/regulations	
Degree of pollution / Overvoltage category	
Connection data solid/stranded/AWG	
Dimensions	W / H / D
EMC note	

Technical data	
24 V DC	
See diagram	
12 mA	
5 ms	
8 ms	
Yellow LED, reverse polarity protection, freewheeling diode	
REL-MR-18DC/21	REL-MR-18DC/21AU
Single contact, 1-PDT	Single contact, 1-PDT
AgSnO	AgSnO, hard gold-plated
250 V AC/DC	30 V AC / 36 V DC
5 V (at 100 mA)	100 mV (at 10 mA)
3 A	50 mA
on request	50 mA
10 mA (at 12 V)	1 mA (at 24 V)
4 kV (50 Hz, 1 min.)	
-25 °C ... 70 °C	
2 x 10 ⁷ cycles	
IEC 60664, EN 50178	
3 / III	
0.14 - 2.5 mm ² / 0.14 - 2.5 mm ² / 26 - 14	
6.2 mm / 80 mm / 94 mm	
Class A product, see page 605	

Description	Voltage U _N
PLC-INTERFACE basic terminal block, for plug-in miniature relay	
with Push-in connection	24 V DC

Plug-in miniature relays
REL-MR- 18DC/21
REL-MR- 18DC/21AU

Ordering data		
Type	Order No.	Pcs./ Pkt.
PLC-BPT- 24DC/21RW	2900261	10

Accessories		
Type	Order No.	Pcs./ Pkt.
REL-MR- 18DC/21	2961383	10
REL-MR- 18DC/21AU	2961493	10

PLC-INTERFACE for railway applications

Relay module for input voltages with a nominal frequency of 16.7 Hz

The advantages:

- Input nominal frequency 16.7 Hz
- Vibration and shock resistance according to EN 50155
- Safe isolation according to DIN EN 50178 between coil and contact
- Push-in connection technology

Notes:
Type of insulating housing: Polyamide PBT, non-reinforced, color: green.
Marking systems and mounting material See Catalog 3
The PLC-ATP partition plate must be installed for voltages larger than 250 V (L1, L2, L3) between identical terminal blocks in adjacent modules. Potential bridging is then carried out with FBST 8-PLC... or FBST 500....
If the specified maximum values for multi-layer contact relays are exceeded, the gold plating is destroyed. The values in parentheses then apply for further operation. This can result in a shorter service life than with a pure power contact.



2-PDT relay module for 16.7 Hz input frequency, max. 2 x 6 A

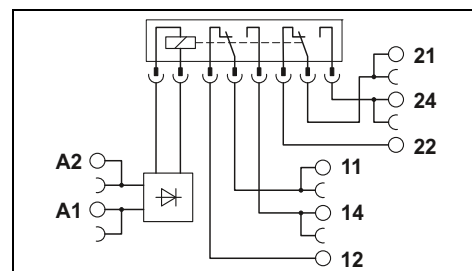

Technical data

Input data	
Nominal input voltage U_N	230 V AC
Input nominal frequency	16.67 Hz
Permissible range (with reference to U_N)	see diagram
Typical response time at U_N	20 ms
Typical release time at U_N	60 ms
Input circuit	Yellow LED, bridge rectifier
Output data	
Contact type	2 PDT
Contact material	AgNi, hard gold-plated
Max. switching voltage	30 V AC / 36 V DC (250 V AC/DC)
Minimum switching voltage	100 mV (5 V AC/DC)
Limiting continuous current	50 mA (6 A)
Maximum switch-on current	50 mA (8 A)
Minimum switching current	1 mA (10 mA)
General data	
Test voltage input/output	6 kV
Ambient temperature (operation)	-25 °C ... 55 °C
Mechanical service life	approx. 3×10^7 cycles
Standards/regulations	IEC 60664, EN 50178
Degree of pollution / Overvoltage category	2 / III
Connection data solid/stranded/AWG	0.14 - 2.5 mm ² / 0.14 - 2.5 mm ² / 26 - 14
Dimensions	14 mm / 80 mm / 94 mm
EMC note	Class A product, see page 605

Permissible input voltage range for PLC-RSP-230UC/21-21AU/RWF

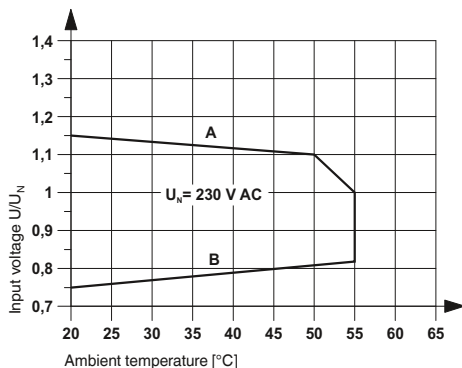

Curve A
Maximum continuous voltage when limiting continuous current = 6 A

Curve B
Minimum pick-up voltage for pre-excitation with U_N and limiting continuous current = 6 A

Description	Voltage U_N
PLC-INTERFACE with Push-in connection	230 V AC

Ordering data

Type	Order No.	Pcs./Pkt.
PLC-RPT-230UC/21-21AU/RWF	2900345	10

Relay modules

Highly compact relay modules - PLC-INTERFACE

PLC-INTERFACE for railway applications

Relay modules with extended input voltage and temperature range, specifically designed for railway applications

The advantages:

- Certified to EN 50155
- Optimum relay operation thanks to wide-range electronics
- Temperature range -40 to +70°C (short-term 85°C)
- Input voltage range 0.7 to 1.25 x U_N (short-term 1.4 x U_N)
- Vibration and shock resistance according to EN 50155
- Safe isolation according to DIN EN 50178 between coil and contact
- Push-in connection technology

Notes:
Type of insulating housing: Polyamide PBT, non-reinforced, color: green.
Marking systems and mounting material See Catalog 3
The PLC-ATP partition plate must be installed for voltages larger than 250 V (L1, L2, L3) between identical terminal blocks in adjacent modules. Potential bridging is then carried out with FBST 8-PLC... or FBST 500....
If the specified maximum values for multi-layer contact relays are exceeded, the gold plating is destroyed. The maximum values of the power contact relay are then valid. This can result in a shorter service life than with a pure power contact.
Electrical service life diagrams, see page 400



1-PDT relay module, 6 A, maximum

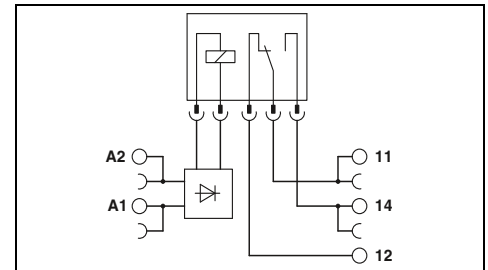

Input data	
Permissible range (with reference to U _N)	
Typical input current at U _N	[mA]
Typical response time at U _N	[ms]
Typical release time at U _N	[ms]
Input protection:	
Output data	
Contact type	
Contact material	
Max. switching voltage	
Minimum switching voltage	
Limiting continuous current	
Maximum switch-on current	
Minimum switching current	
General data	
Test voltage (winding / contact)	
Ambient temperature (operation)	
Mechanical service life	
Standards/regulations	
Connection data solid/stranded/AWG	
Dimensions	W / H / D
EMC note	

Technical data		
①	②	③
0.7 - 1.25	0.7 - 1.25	
9	3	2
4	4	4
4	4	4
Yellow LED, bridge rectifier, freewheeling diode		
1 PDT	1 PDT	
AgSnO	AgSnO, hard gold-plated	
250 V AC/DC	30 V AC / 36 V DC	
5 V (at 100 mA)	100 mV (at 10 mA)	
6 A	50 mA	
10 A (4 s)	50 mA	
10 mA (at 12 V)	1 mA (at 24 V)	
4 kV _{rms} (50 Hz, 1 min.)		
-40 °C ... 70 °C (Temperature class TX)		
Approx. 2x 10 ⁷ cycles		
EN 50155 (VDE 0115 part 200), EN 50178, EN 61373, EN 50121		
0.14 - 2.5 mm ² / 0.14 - 2.5 mm ² / 26 - 14		
6.2 mm / 80 mm / 94 mm		
Class A product, see page 605		

Description	Input voltage U _N
PLC-INTERFACE, with power contact	
with Push-in connection	① 24 V DC
	② 72 V DC
	③ 110 V DC
PLC-INTERFACE, with hard gold-plated contact	
with Push-in connection	① 24 V DC
	② 72 V DC
	③ 110 V DC

Ordering data		
Type	Order No.	Pcs./Pkt.
PLC-RPT- 24UC/21/RW	2900318	10
PLC-RPT- 72UC/21/RW	2900319	10
PLC-RPT-110UC/21/RW	2900320	10
PLC-RPT- 24UC/21AU/RW	2900321	10
PLC-RPT- 72UC/21AU/RW	2900322	10
PLC-RPT-110UC/21AU/RW	2900323	10

Highly compact relay modules - PLC-INTERFACE

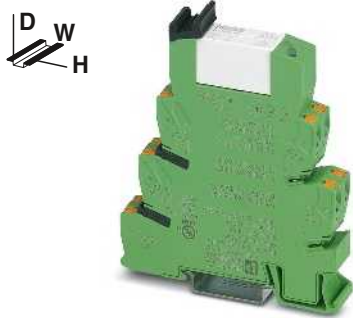

2-PDT relay module,
2 x 6 A, maximum

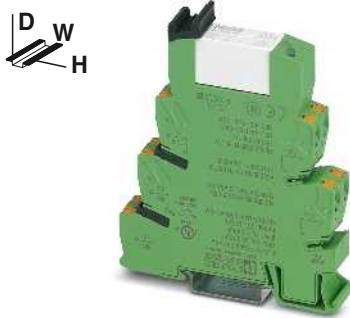

1-PDT relay module,
max. 10 A

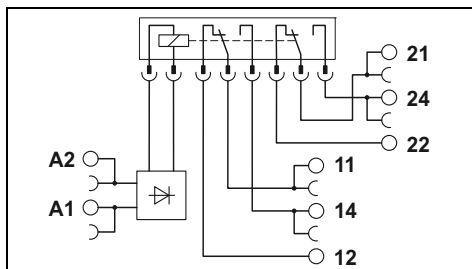

Technical data

①	②	③
0.7 - 1.25	0.7 - 1.25	0.7 - 1.25
20	6	4.5
5	5	5
11	11	11

Yellow LED, bridge rectifier, freewheeling diode

2 PDT	2 PDT
AgNi	AgNi, hard gold-plated
250 V AC/DC	30 V AC / 36 V DC
5 V (at 10 mA)	100 mV (at 10 mA)
6 A	50 mA
15 A (300 ms)	50 mA
10 mA (At 5 V)	1 mA (at 24 V)

5 kV_{rms} (50 Hz, 1 min.)
-40 °C ... 70 °C (Temperature class TX)
approx. 3x 10⁷ cycles
EN 50155 (VDE 0115 part 200), EN 50178, EN 61373, EN 50121

0.14 - 2.5 mm² / 0.14 - 2.5 mm² / 26 - 14
14 mm / 80 mm / 94 mm
Class A product, see page 605

Ordering data

Type	Order No.	Pcs./ Pkt.
PLC-RPT- 24UC/21-21/RW	2900346	10
PLC-RPT- 72UC/21-21/RW	2900347	10
PLC-RPT-110UC/21-21/RW	2900348	10
PLC-RPT- 24UC/21-21AU/RW	2900349	10
PLC-RPT- 72UC/21-21AU/RW	2900350	10
PLC-RPT-110UC/21-21AU/RW	2900351	10

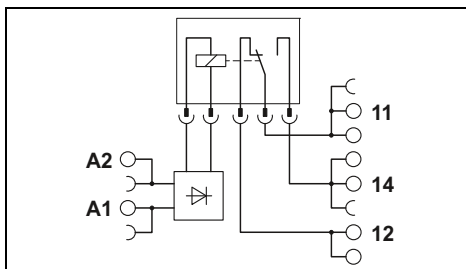

Technical data

①	②	③
0.7 - 1.25	0.7 - 1.25	0.7 - 1.25
20	6	4.5
5	5	5
11	11	11

Yellow LED, bridge rectifier, freewheeling diode

1 PDT
AgNi
250 V AC/DC
12 V (at 10 mA)
10 A (With inserted bridge 2967691)
30 A (300 ms)
10 mA (at 12 V)

5 kV_{rms} (50 Hz, 1 min.)
-40 °C ... 70 °C (Temperature class TX)
approx. 3x 10⁷ cycles
EN 50155 (VDE 0115 part 200), EN 50178, EN 61373, EN 50121

0.14 - 2.5 mm² / 0.14 - 2.5 mm² / 26 - 14
14 mm / 80 mm / 94 mm
Class A product, see page 605

Ordering data

Type	Order No.	Pcs./ Pkt.
PLC-RPT- 24UC/21HC/RW	2900324	10
PLC-RPT- 72UC/21HC/RW	2900325	10
PLC-RPT-110UC/21HC/RW	2900326	10

Derating curve for

PLC-RSP...21/RW
PLC-RSP...21AU/RW
PLC-RSP...21-21/RW
PLC-RSP...21-21AU/RW

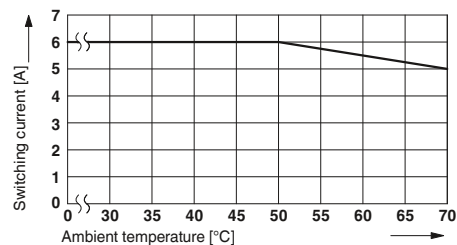

Interrupting rating for PLC-RSP...UC/21RW

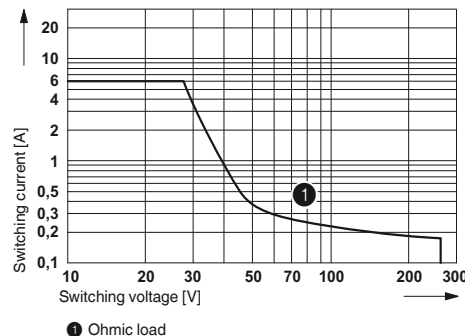

1 Ohmic load

Interrupting rating for PLC-RSP...UC/21-21/RW

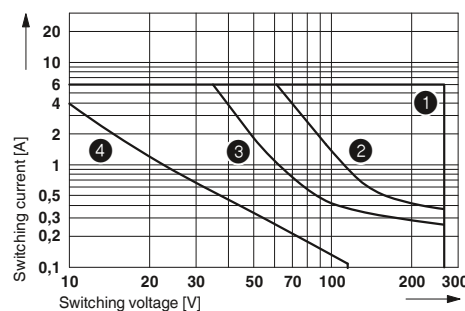

1 AC, ohmic load
2 DC, ohmic load, contacts in series
3 DC, ohmic load
4 DC, L/R = 40 ms

Interrupting rating for PLC-RSP...UC/21HC/RW

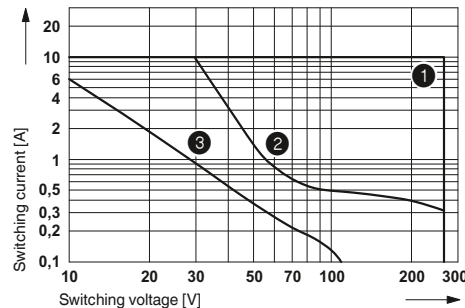

1 AC, ohmic load
2 DC, ohmic load
3 DC, L/R = 40 ms

Relay modules

Highly compact relay modules - PLC-INTERFACE

PLC electronic sensor terminal block for NAMUR proximity sensors

The electronic sensor terminal block, PLC-...-EIK 1-SVN from Phoenix converts the changeable resistance of a NAMUR sensor unit into a digital signal that can be read by all PLCs.

In addition, the electronics monitors the sensor side for a short circuit or open circuit and indicates these errors via an integrated LED.

Due to a corresponding resistance circuit, the PLC-...-EIK 1-SVN can be used to monitor all mechanical switches (N/C contact or N/O contact) for short-circuits and/or wire break.

In addition to a high packing density, this switching amplifier features the following:

- Regulated power supply for the NAMUR proximity switch
- 24 V/50 mA digital output for directly connecting programmable logic controllers
- Connection option for PLC-V8 adapter
- Screw and Push-in connection technology

Notes:
Type of insulating housing: Polyamide PBT, non-reinforced, color: green.
Marking systems and mounting material See Catalog 3
The PLC-ATP partition plate is to be used in the following cases: always at the start and end of a PLC terminal strip, for voltages greater than 250 V (L1, L2, L3) between the same terminal points of neighboring modules (potential bridging then takes place with FBST 8-PLC... or FBST 500...) and with safe isolation between neighboring modules.



For inductive proximity sensors acc. to NAMUR, with light indicators for sensor signal and fault

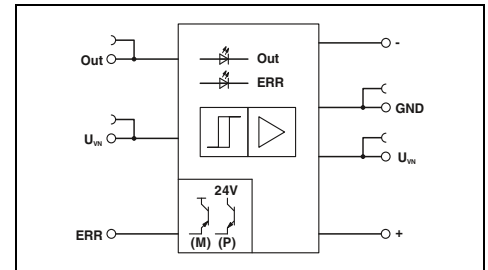

Technical data

Supply
Input supply nominal voltage U_{VN}
Typical input current at U_{VN}
Transmission frequency f_{limit}
Input circuit

24 V DC
approx. 14 mA
approx. 350 Hz
Green LED, reverse polarity protection, surge protection

Control circuit
No-load voltage
Switching points in accordance with EN 60947-5-6:

8.2 V DC $\pm 10\%$
 ≥ 2.1 mA (In conductive state)
 ≤ 1.2 mA (In blocking state)
6.3 mA ... 10 mA (in the event of a short-circuit)
0 mA ... 0.35 mA (In the event of a wire break)
Surge protection

Protective circuit
Alarm output
Operating voltage range (positive switching)
Limiting continuous current
Voltage drop at maximum limiting continuous current
Output protection
Signal output
Limiting continuous current
Voltage drop U_R at maximum limiting continuous current

$U_{VN} - U_{Res}$
50 mA
 ≤ 1.5 V (U_R)
Red LED, surge protection

Output protection
General data
Rated insulation voltage
Rated surge voltage / insulation
Ambient temperature (operation)
Standards/regulations
Degree of pollution / Overvoltage category

Surge protection
50 V DC
0.4 kV/Basic isolation
-25 °C ... 50 °C
IEC 60664 , EN 50178
2 / 1

Connection data solid/stranded/AWG	0.14 - 2.5 mm ² / 0.14 - 2.5 mm ² / 26 - 12
Dimensions	6.2 mm / 80 mm / 86 mm
EMC note	Class A product, see page 605

0.14 - 2.5 mm² / 0.14 - 2.5 mm² / 26 - 12
6.2 mm / 80 mm / 86 mm
Class A product, see page 605

Ordering data

Type	Order No.	Pcs./ Pkt.
PLC-SC-EIK 1-SVN 24P/P	2982663	10
PLC-PT-EIK 1-SVN 24P/P	2900397	10

Accessories

UKK 5-2R/NAMUR	2941662	50
----------------	---------	----

Application 1

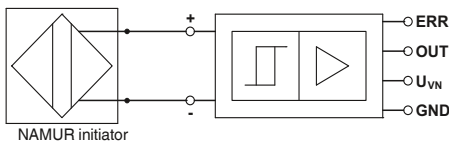

Application 2

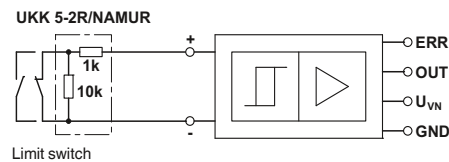

Initiator state	Switching level		LED	
	OUT	ERR	Green	Red
Conductive	L	L	OFF	OFF
Blocking	H	L	ON	OFF
Short circuit	L	H	OFF	ON
Open circuit	L	H	OFF	ON

Description
Switching amplifier electronic terminal block, positive switching
with screw connection
with Push-in connection

Double-level terminal block, with pre-assembled resistors
with screw connection

PLC series

Electronic reversing load relay for DC motors

The PLC-S...-ELR W 1/2-24DC electronic reversing load relays are used to switch mechanically commutated DC motors up to 24 V/2 A.

- Wear-free reversing
- Braking by controlling both inputs
- Short-circuit and surge and overload-proof output
- Integrated locking circuit and load wiring
- Screw or spring-cage connection technology

Notes:
Type of housing: Polyester PBT, non-reinforced, color: green.
Marking systems and mounting material See Catalog 3
The PLC-ATP partition plate is to be used in the following cases: always at the start and end of a PLC terminal strip, for voltages greater than 250 V (L1, L2, L3) between the same terminal points of neighboring modules (potential bridging then takes place with FBST 8-PLC... or FBST 500...) and with safe isolation between neighboring modules.
For the protection of input and output, inductive loads must be dampened with an effective protection circuit.
PWM = Pulse Width Modulation



DC reversing load relay with overload and short-circuit-proof output

Application example for PLC-S...ELR W 1/2-24DC

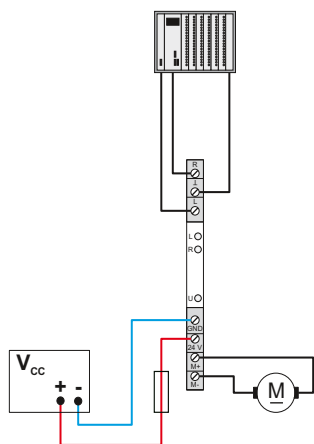

Status table

Input		Output	
Right	Left	M +	M -
0	0	High resistance	High resistance
1	0	+ 24 V	GND
0	1	GND	+ 24 V
1	1	GND	GND

Derating curve for PLC-S...ELR W 1/2-24DC

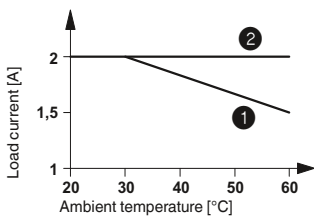

- ① Aligned without spacing
- ② Aligned with > 20 mm spacing

Input data	Control voltage U_{ST} right/left Control input current I_{ST} right/left Input protection:
PWM option	Maximum clock frequency of the PWM at the control inputs
	Pulse width repetition rate of the PWM
Output data	Supply voltage range U_V Quiescent current Output protection
Motor switching output	Continuous current I_A max. Current limitation at short-circuits
General data	Rated insulation voltage Rated surge voltage / insulation Ambient temperature (operation) Standards/regulations Degree of pollution / Overvoltage category
Mounting position	Mounting Connection data solid/stranded/AWG Dimensions
EMC note	

Description	Electronic reversing load relays , for driving DC motors, with light indicator and protection circuit
	with screw connection with spring-cage connection

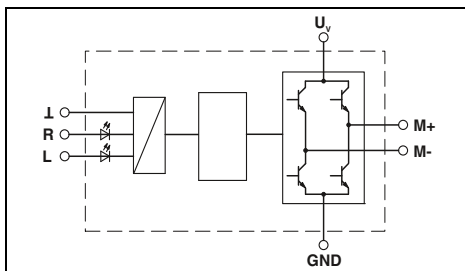

Technical data

24 V DC $\pm 20\%$ approx. 3 mA Yellow LED, reverse polarity protection, surge protection
1000 Hz
0% ... 100%
10 V DC ... 30 V DC 10 mA Green LED, reverse polarity protection, surge protection
2 A (see derating curve) 15 A (during braking)
50 V 0.5 kV / Basic insulation -25 °C ... 60 °C IEC 60664 , EN 50178 2 / II
Vertical (horizontal DIN rail) In rows with zero spacing 0.14 - 2.5 mm ² / 0.14 - 2.5 mm ² / 26 - 14 6.2 mm / 80 mm / 86 mm Class A product, see page 605

Ordering data

Type	Order No.	Pcs./ Pkt.
PLC-SC-ELR W1/ 2-24DC	2980539	1
PLC-SP-ELR W1/ 2-24DC	2980555	1

Relay modules

Highly compact relay modules - PLC-INTERFACE

PLC-INTERFACE

Pulse expansion module

A solid-state relay for acquiring and extending short pulses.

- Pulse detection can be set from > 0.1 ms or > 2 ms
- Status display
- Delay times of 10 to 2550, can be set via DIP switches
- Bridging options
- Can be retriggered
- Screw and Push-in connection technology



Solid-state relay module for the extension of input pulses, DC output max. 100 mA

ERC

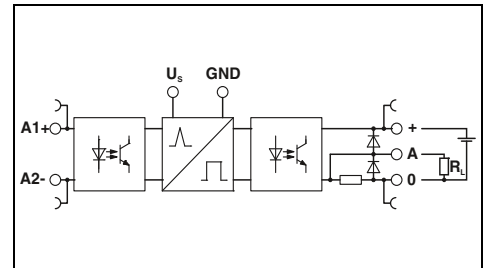

Technical data

Input data			
Rated control supply voltage U_s	24 V DC		
Rated control supply voltage range with reference to U_s	0.8 ... 1.2		
Rated control supply current I_s			
- Input low, output low	13 mA		
- Input high, output high	19 mA		
Rated actuating voltage U_c	24 V DC		
Rated actuating current I_c	3 mA		
Switching threshold "0" signal in reference to U_c	< 0.4		
Switching threshold "1" signal in reference to U_c	> 0.8		
Status indication	Yellow LED		
Operating voltage display	Green LED		
Input circuit	Reverse polarity protection, surge protection		
Output data			
Output voltage range U_E	3 V DC ... 48 V DC		
Limiting continuous current	100 mA		
Voltage drop at maximum limiting continuous current	< 1 V DC		
Output circuit	3-conductor, ground-referenced		
Output protection	Reverse polarity protection, surge protection, free running		
General data			
Rated insulation voltage	50 V DC		
Rated surge voltage	0.5 kV		
Ambient temperature (operation)	-25 °C ... 60 °C		
Standards/regulations	DIN EN 50178		
Connection data solid/stranded/AWG	0.14 - 2.5 mm ² / 0.14 - 2.5 mm ² / 26 - 14		
Dimensions	6.2 mm / 80 mm / 86 mm		
EMC note	Class A product, see page 605		
	W / H / D		
Ordering data			
Description	Type	Order No.	Pcs./ Pkt.
PLC-INTERFACE, with screw connection	PLC-OSC-LPE-24DC/48DC/100	2903171	1
PLC-INTERFACE, with Push-in connection	PLC-OPT-LPE-24DC/48DC/100	2903173	1

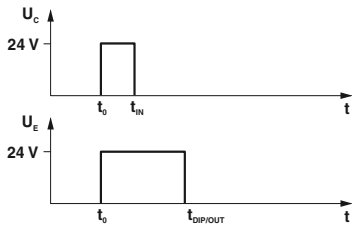

Input pulse $t_1 <$ set output pulse t_3
(no restart when triggered again)

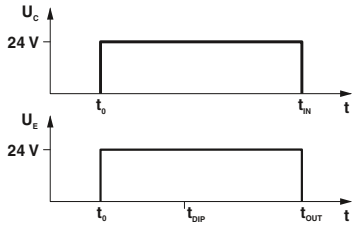

Input pulse $t_1 \geq$ set output pulse t_3 then:
input pulse $t_1 =$ output pulse t_2
(no restart when triggered again)

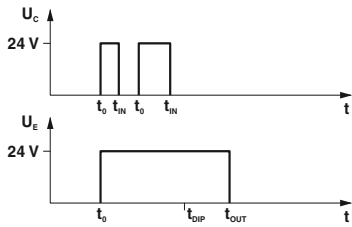

Input pulse $t_1 <$ set output pulse t_3
(restart when triggered again)

DIP							
S1	S2	S3	S4	S5	S6	S7	S8
10	-	-	-	-	-	-	-
-	20	-	-	-	-	-	-
-	-	40	-	-	-	-	-
-	-	-	80	-	-	-	-
-	-	-	-	160	-	-	-
-	-	-	-	-	320	-	-
-	-	-	-	-	-	640	-
-	-	-	-	-	-	-	1280

Relay modules

Highly compact relay modules - PLC-INTERFACE

PLC accessories

The **PLC-ESK** power terminal is used to supply the bridge potentials, the **PLC-ATP** partition plate is used for the visual separation and safe isolation of adjacent PLC modules. The **PLC-BP (A1-14)** passive feed-through bridge is used instead of a relay and connects the A1 and 14 terminal points.



Power terminal and partition plate



Feed-through bridge

Ordering data			Ordering data				
Description	Color	Type	Order No.	Pcs./ Pkt.	Type	Order No.	Pcs./ Pkt.
Power terminal , for supply of up to four potentials, same shape as PLC standard series, max. 32 A/250 V AC		PLC-ESK GY	2966508	5			
Partition plate , 2 mm thick, required at the start and end of a PLC terminal strip. It also serves in visual separation of groups, safe isolation of different voltages of neighboring PLC-INTERFACE devices according to DIN EN 50178/VDE0160, separation of neighboring bridges of different potentials, and separation of PLC-INTERFACE devices at voltages > 250 V	gray	PLC-ATP BK	2966841	25			
Screwdriver Blade: 0.6 x 3.5 x 100 mm, length: 181 mm	black	SZF 1-0,6X3,5	1204517	10			
Passive feed-through bridge , can be plugged in instead of relay or solid-state relay, bridges terminal points A1 and 14	black	PLC-BP A1-14	2980283	10			

PLC accessories

The color-coded and insulated **FBST** plug-in bridges can reduce wiring time by up to 70% for PLC-INTERFACE. The 500 mm long **FBST 500-PLC** “continuous bridges” are particularly effective. The **FBST 6** 2-pos. single plug-in bridges are ideal for bridging a smaller number of PLC modules.

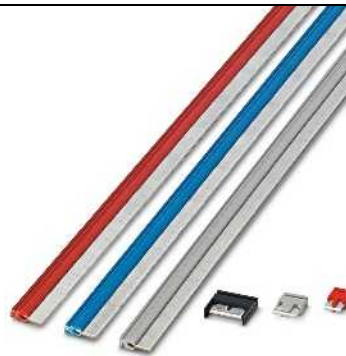

Plug-in bridge systems

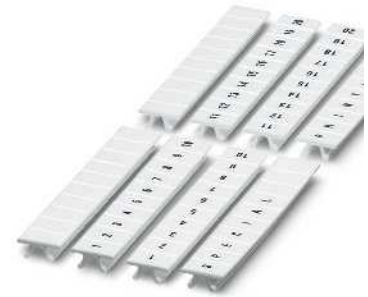

Marking material

Ordering data			Ordering data				
Description	Color	Type	Order No.	Pcs./ Pkt.	Type	Order No.	Pcs./ Pkt.
Cont. plug-in bridge , 500 mm long, insulated, can be cut to length, for potential distribution Nominal current: 32 A	red blue gray	FBST 500-PLC RD FBST 500-PLC BU FBST 500-PLC GY	2966786 2966692 2966838	20 20 20			
Plug-in bridge , 2-pos., 6 mm long, for potential distribution Nominal current: 6 A	red blue gray	FBST 6-PLC RD FBST 6-PLC BU FBST 6-PLC GY	2966236 2966812 2966825	50 50 50			
Plug-in bridge , 2-pos., 8 mm long, for potential distribution with a partition plate Nominal current: 6 A	gray	FBST 8-PLC GY	2967688	50			
Plug-in bridge , 2-pos., 14 mm long, insulated, for potential distribution Nominal current: 10 A	black	FBST 14-PLC BK	2967691	50			
Zack marker strip, printed horizontally , 10-section, with consecutive numbers, e.g., 1-10, 11-20, etc. up to 91-100		ZB 6,LGS:FORTL.ZAHLEN	1051016	10			

Adapter for PLC-INTERFACE

PLC-V8/... are the VARIOFACE adapters which connect the narrow PLC-INTERFACE modules to the VARIOFACE system cabling:

Notes:
Cross-ref. list for matching PLC-INTERFACE modules: page 548

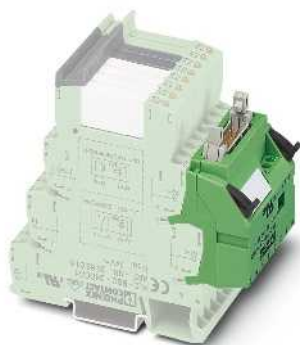

VARIOFACE adapter for 6.2 mm PLC-INTERFACE

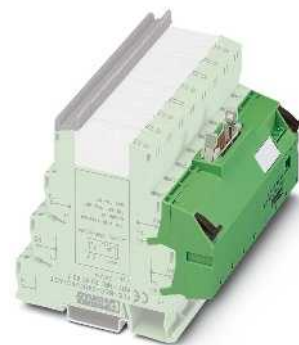

VARIOFACE adapter for 14 mm PLC-INTERFACE



Maximum permissible operating voltage
Maximum permissible current (per branch)
Maximum total current (voltage supply)

Ambient temperature (operation)
Standards/regulations
Connection method

Connection data solid/stranded/AWG
Dimensions

Supply
Controller level
H / D

30 V DC
1 A (per signal path)
3 A
-40 °C ... 70 °C
IEC 60664 , DIN EN 50178
Screw connection
IDC/FLK pin strip
0.2 ... 4 mm² / 0.2 ... 2.5 mm² / 24 - 12
100 mm / 94 mm

30 V DC
1 A (per signal path)
3 A
-40 °C ... 70 °C
IEC 60664 , DIN EN 50178
Screw connection
IDC/FLK pin strip
0.2 ... 4 mm² / 0.2 ... 2.5 mm² / 24 - 12
100 mm / 94 mm

Ordering data

Ordering data

Description	No. of pos.	Module width W
V8 adapter , for 8 PLC-INTERFACE devices (6.2 mm), with IDC/FLK pin strip, for PLC system cabling, positive switching		
Output	14	49.6 mm
Input	14	49.6 mm
V8 adapter , for 8 PLC-INTERFACE devices (6.2 mm), with IDC/FLK pin strip, for PLC system cabling, negative switching		
Output	14	49.6 mm
Input	14	49.6 mm
V8 output adapter , for 8 PLC-INTERFACE devices (6.2 mm), with D-SUB connection		
Pin strip	15	49.6 mm
Socket strip	15	49.6 mm
V8 input adapter , for 8 PLC-INTERFACE devices (6.2 mm), with D-SUB connection		
Pin strip	15	49.6 mm
Socket strip	15	49.6 mm
V8 adapter , for 8 PLC-INTERFACE devices (14 mm), with IDC/FLK pin strip, for PLC system cabling, positive switching		
	14	112.3 mm
V8 adapter , for 8 PLC-INTERFACE devices (14 mm), with IDC/FLK pin strip, for PLC system cabling, negative switching		
	14	112.3 mm

Type	Order No.	Pcs./ Pkt.
PLC-V8/FLK14/OUT	2295554	1
PLC-V8/FLK14/IN	2296553	1
PLC-V8/FLK14/OUT/M	2304102	1
PLC-V8/FLK14/IN/M	2304115	1
PLC-V8/D15S/OUT	2296058	1
PLC-V8/D15B/OUT	2296061	1
PLC-V8/D15S/IN	2296074	1
PLC-V8/D15B/IN	2296087	1

Type	Order No.	Pcs./ Pkt.
PLC-V8L/FLK14/OUT	2299660	1
PLC-V8L/FLK14/OUT/M	2304306	1

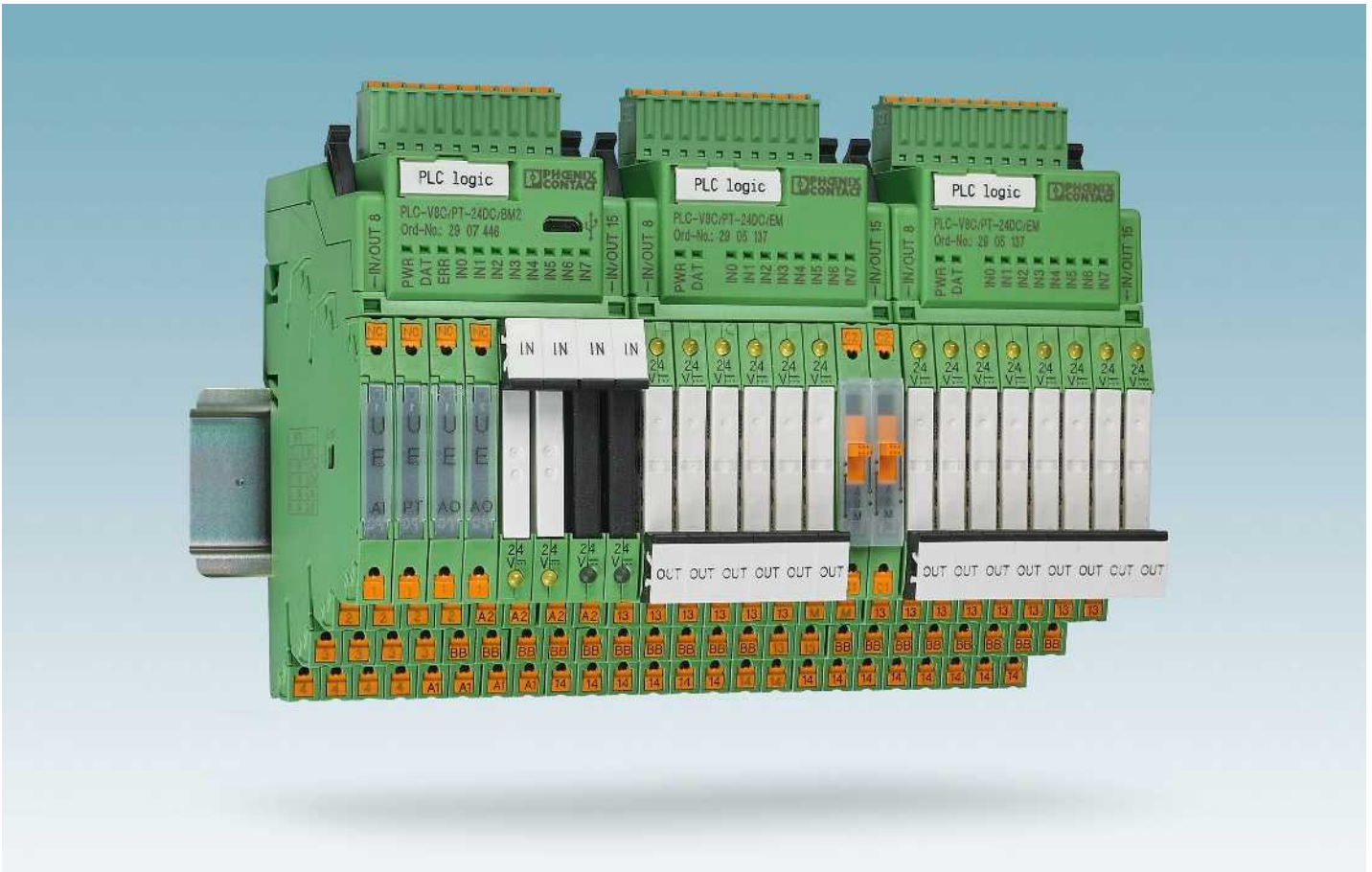

Extremely compact control

The PLC logic programmable logic relay system is the extremely compact way to carry out small automation tasks easily and flexibly. It consists of the PLC-V8C logic modules, the PLC-INTERFACE relay system, and the LOGIC+ software. The logic modules are simply plugged into a row of eight PLC-INTERFACE terminal blocks and combine the logic and interface level in one unit. Depending on the switching requirements, plug-in electromechanical and solid-state relays can be combined in order to flexibly switch and control the I/O signals.

PLC logic processes digital and analog input signals as well as logic functions and timer modules - and replaces conventional switching and control devices. Up to 16 I/O signals can be processed using the stand-alone logic modules - with an overall width of just 50 mm. If more I/O signals are required, a maximum of 48 I/O signals can be linked using the basic and extension modules.

Switching and controlling with plug-in relays

- PLC logic brings together the standard combination of logic module and separate plug-in relay and eliminates the wiring effort and additional switching elements.
- Convenient connections with screw or Push-in connection technology, which also accommodate return conductors, remove the need for separate potential terminal blocks
- Each channel can be freely configured as an input or output and with relay or analog modules

Intuitive programming

Programming is quick and easy with the intuitive LOGIC+ programming software. Ladder (LD) and function block diagrams (FBD) can be created by selecting the relevant functions and their connection using drag & drop. The graphical representation of PLC logic in the hardware editor supports intuitive operation. The programs created can be simulated offline on the PC and tested online during operation. Basic functions, such as AND, OR, NOT, etc. are complemented by special functions, such as counters, seven-day timers, timer modules, and mathematical functions, to name a few.



Logic module with plug-in relays

PLC logic combines a logic module and plug-in relay and eliminates the wiring effort and additional switching elements. Each relay channel can be flexibly equipped with an electromechanical or a solid-state relay. PLC logic processes 16 I/O signals with just one logic module and boasts an extremely compact overall width of just 50 mm.

Intuitive programming with LOGIC+

- Function block diagram or ladder diagram
- Numerous integrated function blocks
- Specific function blocks are available to download
- Hardware view in the program
- Can be downloaded free of charge

Standard programming cable

PLC logic is connected to a PC via a standard micro USB cable. The drivers for PLC logic can be downloaded at phoenixcontact.com.

i Your web code: #0139

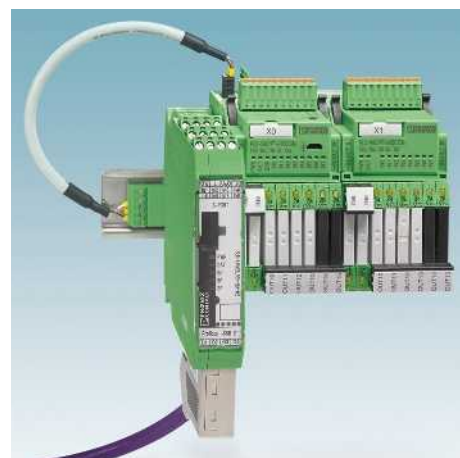
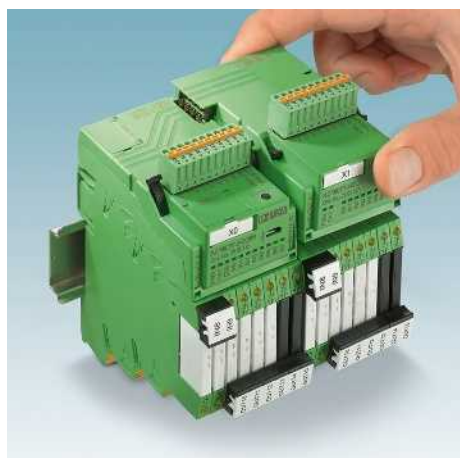

Easily connect extension modules

The basic module and the extension module are connected via integrated connectors - no tools required. A maximum of two extension modules can be connected to a basic module. This means that PLC logic can work with up to 48 I/Os.

Control and monitor via Bluetooth adapter

Together with the PLC logic app, the Bluetooth adapter is available for wireless access to process data between the logic module and the mobile terminal device, and can be used for operation and monitoring purposes.

The Bluetooth connection enables efficient monitoring of multiple logic modules, with just one visualization device.

Integration into common bus systems

PLC logic is integrated into various networks via optional adaptable fieldbus gateways. This enables bidirectional communication with a higher-level controller for remote control as well as diagnostics and visualization.

Gateways are available for transmitting data via PROFIBUS DP, RS-232, RS-485, Modbus/TCP, DeviceNet™, CANopen®, PROFINET, and EtherNet/IP™.

Relay modules

Programmable logic relay system - PLC logic

Logic modules

new

PLC-V8C are the plug-in logic modules which form the PLC logic relay system in conjunction with the narrow 6.2 mm PLC-INTERFACE terminal blocks. Eight freely selectable PLC-INTERFACE terminal blocks must be separately ordered for each logic module. You can find an overview of matching PLC-INTERFACE terminal blocks on page 434.

All logic modules feature these properties:

- 8 integrated digital inputs (of which two inputs are configurable as analog inputs), connection via connector with screw or Push-in connection technology
- A further 8 channels can be configured with matching PLC-INTERFACE terminal blocks as inputs or outputs
- Programming with LOGIC+ software

PLC-V8C.../SAM2

- Stand-alone logic module with 16 I/Os, not extendable
- Connection to PC via micro USB socket
- Integrated real-time clock (RTC)
- Accommodates external IFS-CONFSTICK memory module
- Relay and analog modules can be used

PLC-V8C.../BM2

- Basic logic module with 16 I/Os, can be extended with a maximum of two extension modules (PLC-V8C.../EM) to 48 I/Os
- Connection to PC via micro USB socket
- Integrated real-time clock (RTC)
- Accommodates external IFS-CONFSTICK memory module
- Optional connection to IFS gateways
- Relay and analog modules can be used

PLC-V8C.../EM

- Extension logic module with 16 I/Os, for extending the basic module
- Relay modules can be used



Stand-alone module

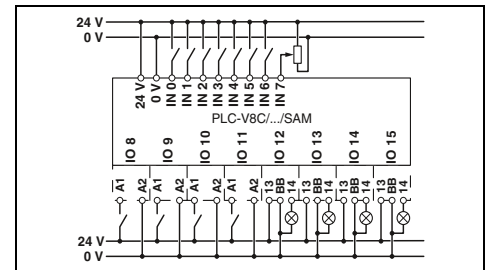

Technical data

Supply	
Supply voltage	24 V DC
Supply voltage range	19.2 V DC ... 26.4 V DC
Maximum input current at U_N	160 mA
Input data (digital)	
Number of inputs	8 (2 configurable as analog)
Input voltage	24 V DC
Description of the input	EN 61131-2, type 3
Input current 0-signal	< 1 mA
Input current 1-signal	typ. 2.5 mA
Input data (analog)	
Number of inputs	2 (IN6 and IN7 are configurable as analog)
Input voltage range	0 V ... 10 V
Input resistance	> 3.5 kΩ
Input data (PLC-INTERFACE)	
Number of inputs	≤ 8
Output data (for controlling PLC-INTERFACE)	
Number of outputs	≤ 8
Nominal voltage	24 V DC
Nominal current	9 mA
Real-time clock (basic module only)	
Buffer time (capacitor)	96 h (Capacitor)
Real-time clock accuracy	±2 s/d
General data	
Ambient temperature (operation)	-20 °C ... 50 °C
Ambient temperature (storage/transport)	-20 °C ... 70 °C
Permissible humidity (operation)	95 %
Air clearances and creepage distances between the power circuits	DIN EN 50178
Rated insulation voltage	50 V
Rated surge voltage	0.8 kV
Insulation	Basic insulation
Mounting type	Can be plugged onto 8 x PLC-INTERFACE
Degree of protection	IP20
Screw connection solid/stranded/AWG	0.14 - 1.5 mm ² / 0.14 - 1.5 mm ² / 28 - 16
Push-in connection solid/stranded/AWG	0.14 - 1.5 mm ² / 0.14 - 1.5 mm ² / 26 - 16

Ordering data

Description	Type	Order No.	Pcs./Pkt.
PLC-V8C plug-in logic modules with screw connection with Push-in connection	PLC-V8C/SC-24DC/SAM2	2907445	1
	PLC-V8C/PT-24DC/SAM2	2907443	1

new



Basic module
(can be extended)



Extension module

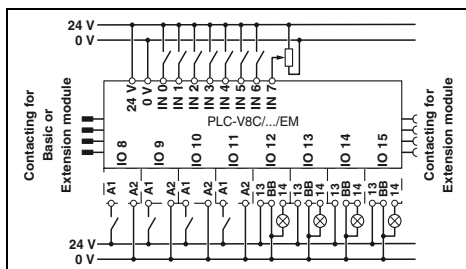
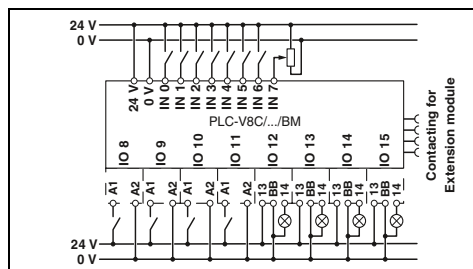

Technical data

Technical data

24 V DC
19.2 V DC ... 26.4 V DC
160 mA

24 V DC
19.2 V DC ... 26.4 V DC
65 mA

8 (2 configurable as analog)
24 V DC
EN 61131-2, type 3
< 1 mA
typ. 2.5 mA

8 (2 configurable as analog)
24 V DC
EN 61131-2, type 3
< 1 mA
typ. 2.5 mA

2 (IN6 and IN7 are configurable as analog)

2 (IN6 and IN7 are configurable as analog)

0 V ... 10 V
> 3.5 kΩ

0 V ... 10 V
> 3.5 kΩ

≤ 8

≤ 8

≤ 8
24 V DC
9 mA

≤ 8
24 V DC
9 mA

96 h (Capacitor)
±2 s/d

-
-

-20 °C ... 50 °C
-20 °C ... 70 °C
95 %
DIN EN 50178

-20 °C ... 45 °C
-20 °C ... 70 °C
95 %
DIN EN 50178

50 V
0.8 kV
Basic insulation
Can be plugged onto 8 x PLC-INTERFACE
IP20
0.14 - 1.5 mm² / 0.14 - 1.5 mm² / 28 - 16
0.14 - 1.5 mm² / 0.14 - 1.5 mm² / 26 - 16

50 V
0.8 kV
Basic insulation
Can be plugged onto 8 x PLC-INTERFACE
IP20
0.14 - 1.5 mm² / 0.14 - 1.5 mm² / 28 - 16
0.14 - 1.5 mm² / 0.14 - 1.5 mm² / 26 - 16

Ordering data

Ordering data

Type	Order No.	Pcs./ Pkt.
PLC-V8C/SC-24DC/BM2	2907447	1
PLC-V8C/PT-24DC/BM2	2907446	1

Type	Order No.	Pcs./ Pkt.
PLC-V8C/SC-24DC/EM	2903095	1
PLC-V8C/PT-24DC/EM	2905137	1

Relay modules

Programmable logic relay system - PLC logic

Analog modules

Together with the PLC logic logic modules, the analog modules enable standard analog signals to be processed.

The analog modules are connected to PLC logic stand-alone modules or basic modules.

- Screw and Push-in connection technology
- Status indicator for supply voltage and diagnostics
- Standard configuration: 4 to 20 mA or Pt 100

Analog input

- Available standard signals: 0 to 20 mA, 4 to 20 mA, 0 to 10 V or 2 to 10 V (configurable via DIP switch)

Temperature transducer

- 2-conductor Pt 100 or Pt 1000 (configurable via DIP switch)
- Temperature measuring range: -50 to 200°C

Analog output

- Available standard signals: 0 to 20 mA, 4 to 20 mA, 0 to 10 V or 2 to 10 V (configurable via DIP switch)

Notes:
The analog modules cannot be operated separately and must only be used in connection with the PLC logic logic modules.



new

Analog input

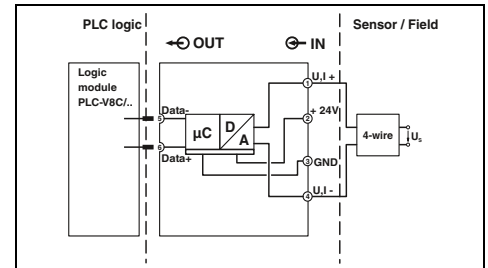

Supply	
Rated control supply voltage U_S	24 V DC
Rated control supply voltage range with reference to U_S	0.8 ... 1.1
Rated control supply current I_S	13 mA
Operating voltage display	Green LED
Input signal	
Input signal	Voltage input
	0 V ... 10 V
	2 V ... 10 V
	> 120 kΩ
Output data	
Output signal	-
Maximum output signal	-
Load R_B	-
Ripple	-
General data	
Ambient temperature (operation)	-20 °C ... 50 °C
Ambient temperature (storage/transport)	-20 °C ... 70 °C
Air clearances and creepage distances between the power circuits	DIN EN 50178
Rated insulation voltage	50 V
Rated surge voltage	0.5 kV
Insulation	Basic insulation
Mounting type	In rows with zero spacing
Degree of protection	IP20
Screw connection solid/stranded/AWG	0.14 - 2.5 mm ² / 0.14 - 2.5 mm ² / 26 - 14
Push-in connection solid/stranded/AWG	0.14 - 2.5 mm ² / 0.14 - 2.5 mm ² / 26 - 14

Technical data

Technical data	
24 V DC	
0.8 ... 1.1	
13 mA	
Green LED	
Voltage input	
0 V ... 10 V	
2 V ... 10 V	
> 120 kΩ	
Current input	
0 mA ... 20 mA	
4 mA ... 20 mA	
~ 40 Ω	
-	
-	
-	
-	
General data	
-20 °C ... 50 °C	
-20 °C ... 70 °C	
DIN EN 50178	
50 V	
0.5 kV	
Basic insulation	
In rows with zero spacing	
IP20	
0.14 - 2.5 mm ² / 0.14 - 2.5 mm ² / 26 - 14	
0.14 - 2.5 mm ² / 0.14 - 2.5 mm ² / 26 - 14	

Ordering data	
Description	
Analog input	
with screw connection	
with Push-in connection	
Temperature transducer	
with screw connection	
with Push-in connection	
Analog output	
with screw connection	
with Push-in connection	

Ordering data

Type	Order No.	Pcs./ Pkt.
PLC-ASC-UI-IN	2906916	1
PLC-APT-UI-IN	2906917	1

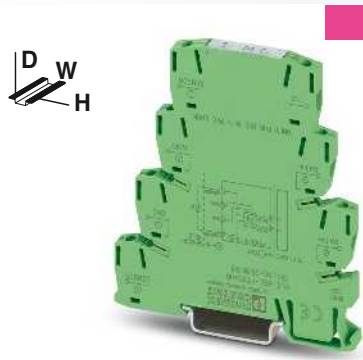

new

Temperature transducer

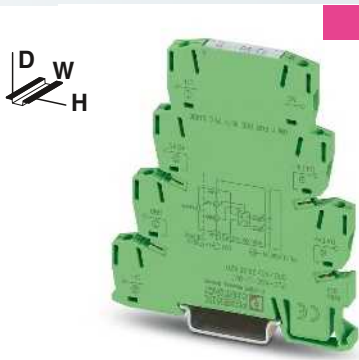

new

Analog output

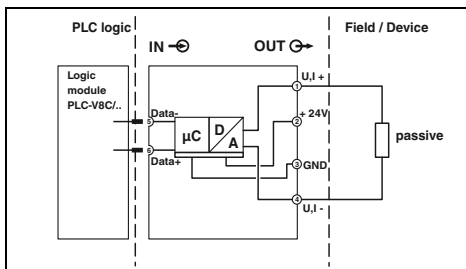
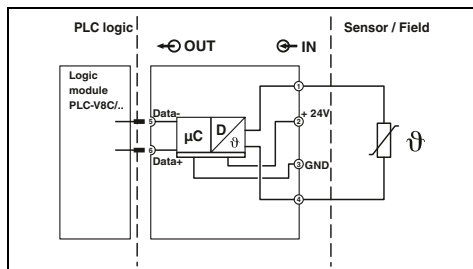

Technical data

Technical data

24 V DC
0.8 ... 1.1
14 mA
Green LED
Temperature range
-50 °C ... 200 °C
-
-
-
-
-
-
-20 °C ... 50 °C
-20 °C ... 70 °C
DIN EN 50178
50 V
0.5 kV
Basic insulation
In rows with zero spacing
IP20
0.14 - 2.5 mm ² / 0.14 - 2.5 mm ² / 26 - 14
0.14 - 2.5 mm ² / 0.14 - 2.5 mm ² / 26 - 14

24 V DC	
0.8 ... 1.1	
14 mA (U _{Out} = 10 V)	
Green LED	
-	
-	
Voltage output	Current output
0 V ... 10 V	0 mA ... 20 mA
2 V ... 10 V	4 mA ... 20 mA
12.3 V	24.6 mA
10 kΩ	500 Ω (20 mA)
< 20 mV _{pp}	-
-	
-20 °C ... 50 °C	
-20 °C ... 70 °C	
DIN EN 50178	
50 V	
0.5 kV	
Basic insulation	
In rows with zero spacing	
IP20	
0.14 - 2.5 mm ² / 0.14 - 2.5 mm ² / 26 - 14	
0.14 - 2.5 mm ² / 0.14 - 2.5 mm ² / 26 - 14	

Ordering data

Ordering data

Type	Order No.	Pcs./ Pkt.
PLC-ASC-PT100-IN	2906918	1
PLC-APT-PT100-IN	2906919	1

Type	Order No.	Pcs./ Pkt.
PLC-ASC-UI-OUT	2906920	1
PLC-APT-UI-OUT	2906921	1

Relay modules

Programmable logic relay system - PLC logic

Accessories

Programming cable and memory module

- The programming cable (MICRO USB B to USB A) is used to connect PLC logic to a PC, length: 2 m
- PLC logic programs are saved by the memory module or can be easily copied to other devices



Cable for programming



Memory module

		Technical data			Technical data		
General data							
EMC note					Class A product, see page 605		
		Ordering data			Ordering data		
Description	Color	Type	Order No.	Pcs./Pkt.	Type	Order No.	Pcs./Pkt.
Programming cable		CAB-USB A/MICRO USB B/2,0M	2701626	1			
Multi-functional memory module for the Interface system					IFS-CONFSTICK	2986122	1
- Flat design							

Accessories

PLC logic starter kit

new

The PLC logic starter kit with 8 inputs and 8 outputs contains all the components needed to get started quickly and easily with PLC logic with Push-in connection technology.

- PLC-V8C-PT/24DC/SAM2 plug-in logic module
- PLC-RPT-24DC/1/ACT eight relay output terminal blocks
- Micro USB programming cable

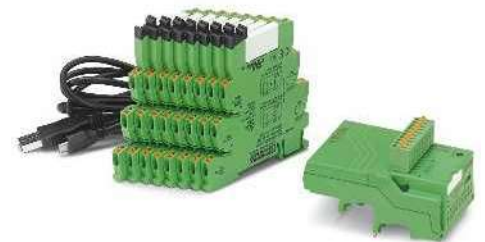

Starter kit with stand-alone module

		Ordering data		
Description	Color	Type	Order No.	Pcs./Pkt.
PLC logic starter kit 3, consisting of: plug-in stand-alone logic module, eight relay output terminal blocks with Push-in connection (250 V AC/DC, max. 6 A), and micro USB programming cable		PLC-LOGIC-STARTERKIT3	2909916	1

Accessories

IFS gateways and Bluetooth adapter

- The gateways are connected to the PLC-V8C.../BM PLC logic basic module via the DIN rail connector and the connecting cable
 - The Bluetooth adapter is connected to the logic module via the memory connection
- Current values are monitored and controlled via the PLC logic app.

INTERFACE system bus master terminal (IB IL IFS-MA-PAC, 2692720) for connecting PLC logic to an Inline controller, see Catalog 6, Automation



IFS gateways



Bluetooth adapter



General data
EMC note

Technical data
Class A product, see page 605

Technical data

Description	Color
IFS gateway for PROFIBUS DP	green
RS-232	green
RS-485	green
Modbus/TCP	green
DeviceNet™	green
CANopen®	green
PROFINET	green
EtherNet/IP™	green
Programming adapter for configuring modules with S-PORT interface Cable length: 3 m	
DIN rail connector	green
Connecting cable for connecting PLC logic with the ME 22,5 TBUS DIN rail connector, cable length: 0.3 m	
Bluetooth programming adapter , with USB and S-PORT interface	

Ordering data		
Type	Order No.	Pcs./Pkt.
EM-PB-GATEWAY-IFS	2297620	1
EM-RS232-GATEWAY-IFS	2901526	1
EM-RS485-GATEWAY-IFS	2901527	1
EM-MODBUS-GATEWAY-IFS	2901528	1
EM-DNET-GATEWAY-IFS	2901529	1
EM-CAN-GATEWAY-IFS	2901504	1
EM-PNET-GATEWAY-IFS	2904472	1
EM-ETH-GATEWAY-IFS	2901988	1
IFS-USB-DATACABLE	2320500	1
ME 22,5 TBUS 1,5/ 5-ST-3,81 GN	2707437	50
PLC-V8C/CAB/TBUS/0,3M	2905263	1

Ordering data		
Type	Order No.	Pcs./Pkt.
IFS-BT-PROG-ADAPTER	2905872	1

Relay modules

Programmable logic relay system - PLC logic

Selection table for PLC-INTERFACE

Relay output	Push-in connection		Screw connection	
	Type	Order No.	Type	Order No.
1 changeover contact, output data 6 A, 250 V AC/DC	PLC-RPT-24DC/21	2900299	PLC-RSC-24DC/21	2966171
1 changeover contact, output data 50 mA, 36 V DC, gold contact	PLC-RPT-24DC/21AU	2900306	PLC-RSC-24DC/21AU	2966265
1 N/O contact, output data 6 A, 250 V AC/DC, actuator type	PLC-RPT-24DC/1/ACT	2900312	PLC-RSC-24DC/1/ACT	2966210
1 N/O contact with switch, output data 6 A, 250 V AC/DC	PLC-RPT-24UC/1/S/H	2900328	PLC-RSC-24UC/1/S/H	2982236
Solid-state relay output				
Output data 100 mA, 3 V DC - 48 V DC	PLC-OPT-24DC/48DC/100	2900352	PLC-OSC-24DC/48DC/100	2966728
Output data 3 A, 3 V DC - 33 V DC	PLC-OPT-24DC/24DC/2	2900364	PLC-OSC-24DC/24DC/2	2966634
Output data 750 mA, 24 V AC - 253 V AC	PLC-OPT-24DC/230AC/1	2900369	PLC-OSC-24DC/230AC/1	2967840
Output data 3 A, 3 V DC - 33 V DC, actuator type	PLC-OPT-24DC/24DC/2/ACT	2900376	PLC-OSC-24DC/24DC/2/ACT	2966676
Output data 750 mA, 24 V AC - 253 V AC, actuator type			PLC-OSC-24DC/230AC/1/ACT	2967947
Output data 1 A, 12 V DC - 300 V DC	PLC-OPT-24DC/300DC/1	2900383	PLC-OSC-24DC/300DC/1	2980678
Output data 10 A, 3 V DC - 33 V DC	PLC-OPT-24DC/24 DC/10/R	2900398	PLC-OSC-24DC/24DC/10/R	2982702
Output data 500 mA, 3 V DC - 48 V DC, electronic changeover contact	PLC-OPT-24DC/48DC/500/W	2900378	PLC-OSC-24DC/48DC/500/W	2980636
Output data, TTL, 50 mA, 5 V DC	PLC-OPT-24DC/TTL	2900363	PLC-OSC-24DC/TTL	2982728
Analog output				
Output signal 0 V ... 10 V, 2 V ... 10 V, 0 mA ... 20 mA, 2 mA ... 20 mA	PLC-APT-UI-OUT	2906921	PLC-ASC-UI-OUT	2906920
Relay input				
Input voltage 24 V DC	PLC-RPT-24DC/1AU/SEN	2900313	PLC-RSC-24DC/1AU/SEN	2966317
Input voltage 120 V AC/DC	PLC-RPT-120UC/1AU/SEN	2900314	PLC-RSC-120UC/1AU/SEN	2966320
Input voltage 230 V AC/DC	PLC-RPT-230UC/1AU/SEN	2900315	PLC-RSC-230UC/1AU/SEN	2966333
Input voltage 5 V DC (basic terminal block without relay)			PLC-BSC-5DC/1/SEN	2980267
Relay for 5 V DC basic terminal block			REL-MR-4,5DC/21AU	2961370
Solid-state relay input				
Input voltage 24 V DC	PLC-OPT-24DC/V8C/SEN	2908172	PLC-OSC-24DC/V8C/SEN	2908173
Input voltage 120 V AC/DC	PLC-OPT-120UC/V8C/SEN	2908174	PLC-OSC-120UC/V8C/SEN	2908175
Input voltage 230 V AC/DC	PLC-OPT-230UC/V8C/SEN	2908176	PLC-OSC-230UC/V8C/SEN	2908177
Analog input				
Input signal 0 V ... 10 V, 2 V ... 10 V, 0 mA ... 20 mA, 2 mA ... 20 mA	PLC-APT-UI-IN	2906917	PLC-ASC-UI-IN	2906916
Input signal: Pt 100 or Pt 1000 sensor	PLC-APT-PT100-IN	2906919	PLC-ASC-PT100-IN	2906918
Dummy or reserve				
Basic terminal blocks output	PLC-BPT-24DC/21	2900445	PLC-BSC-24DC/21	2966016
Basic terminal blocks input	PLC-BPT-24DC/1/SEN	2900262	PLC-BSC-24DC/1/SEN	2966061

LOGIC+ programming software



Integrated web server

PLC logic basic settings are easily configured via the integrated web server. The LOGIC+ software does not need to be installed in order to do so.

- Time and date
- Password and access control
- Firmware update
- Status indicators for inputs and outputs
- General device information

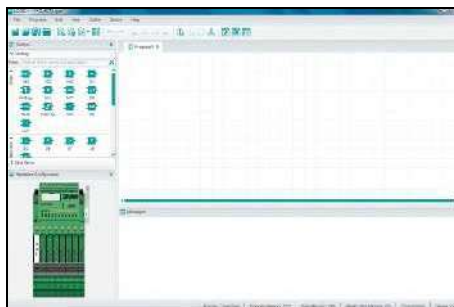

Logic+ user interface

- Clear separation in program editor, toolbox, hardware view, and signaling window
- All elements can be easily placed using drag & drop
- Information and errors are highlighted in color in the program editor



Hardware configurator

- Each channel can be configured as an input or output and with relay or analog modules
- Clear assignment of the inputs and outputs thanks to the graphical representation of the hardware connections

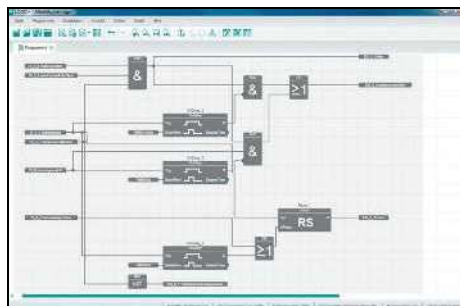

Function blocks

- Basic functions: AND, OR, NOT, XOR
- Mathematical functions: add, divide, multiply, subtract, generate absolute value
- Positive and negative edge detection
- RS and SR flip-flops
- Switch-on and switch-off delay, pulse encoder, pulse stretching, weekly clock timer
- Up and down counter
- Analog and digital comparators
- Special functions, for example, roller shutter control or pulse width modulation are available to download

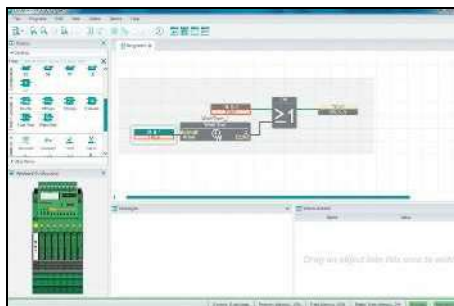

Simulation and online values

- Offline simulation:
 - Simulation of the created program directly in LOGIC+
 - Virtualization of the values in the program editor, hardware view, and in the observation window
- Online values:
 - Representation of the program running on the hardware in LOGIC+ with online values
 - Overwriting values from LOGIC+



PLC logic app

- Once the app is installed on your smartphone or tablet, it can be used to make parameter adjustments to the logic modules. The visualization view is created via the editor of the web server integrated in the logic modules. The app can be used for operation and monitoring, as it can access all program variables.
 - Inputs and outputs (digital, analog)
 - Flags
 - Numerical values
 - Time values

Relay modules

Relay modules in terminal block design - DEK series

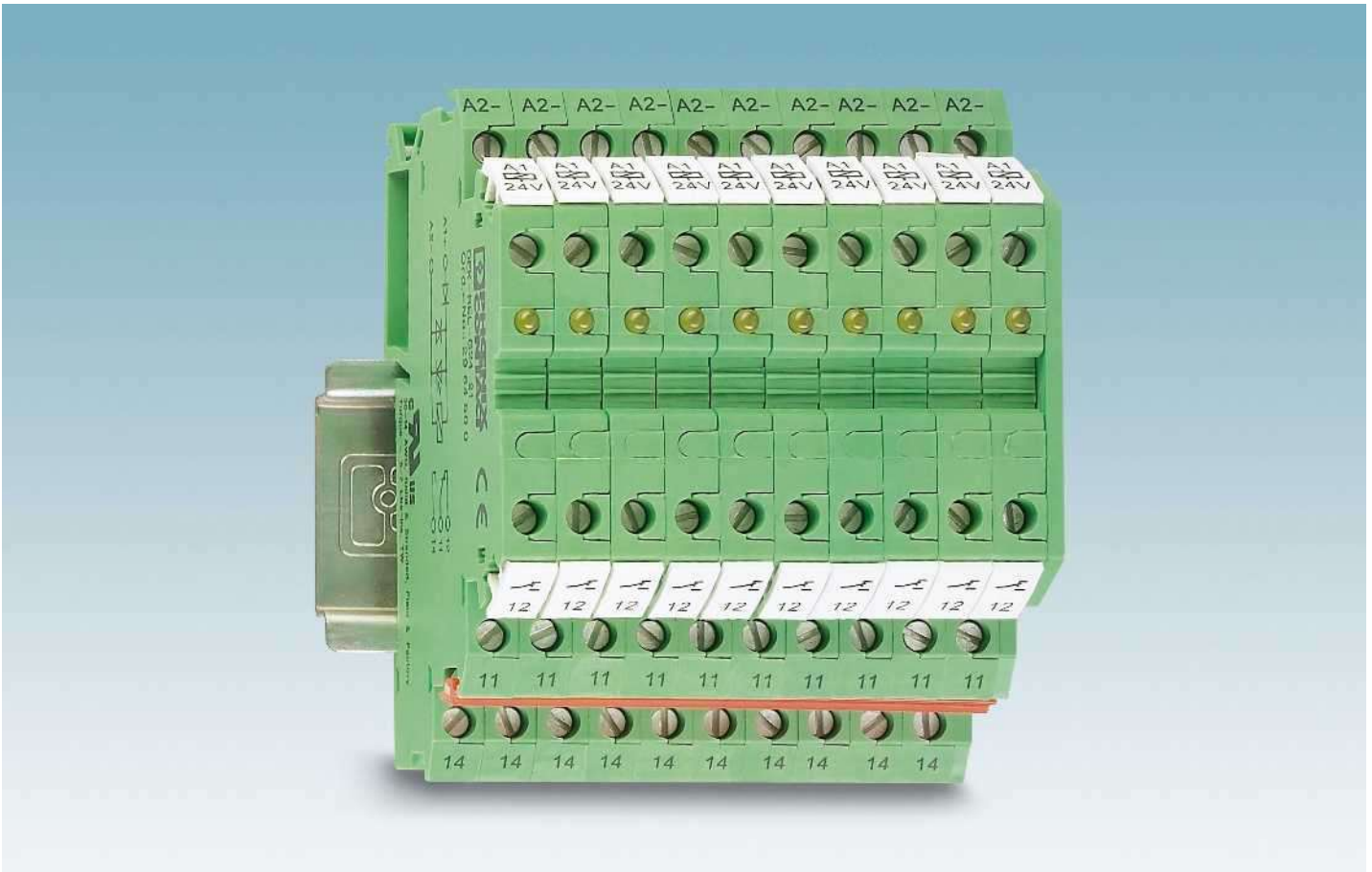

The Phoenix Contact DEK interface terminal blocks provide complete interface functions in terminal block housing that is just 6.2 mm wide. In conjunction with standard terminal block accessories, these high-capacity interfaces have not only the design but also the high level of user convenience of terminal blocks.

The main common feature of all Phoenix Contact interface terminal blocks is their width of just 6.2 mm. This saves 60% space in the control cabinet in comparison to conventional 15 mm wide coupling relays from modular systems.

The DEK range offers the best solution for all industrial voltages both for signal input and output.

High switching capacities are a matter of course for the DEK-REL... relay terminal block and the DEK-OV... solid-state relay terminal block.

The wear-free DEK-OV... power solid-state relay terminal block is used for applications that require a greater switching frequency in which electromechanical relays reach the end of their service life in a short time.

Integrated LEDs clearly indicate the switching status of the electronic terminal blocks and provide an excellent overview of the coupling level and the system.

EB-DIK color-coded insertion bridges for the supply and ground signals make it possible to design the circuit simply and effectively.

Integrated protective circuits such as freewheeling diodes, polarity reversal protection diodes, and surge protection elements protect the coupling modules and ensure optimum availability of the system.

DEK-REL-... relay terminal block

The Phoenix relay terminal block with PDT contact offers the following advantages:

- Width of only 6.2 mm
- High switching capacity of 250 V AC / 6 A
- Less storage, since PDT, N/O or N/C contacts can be wired
- Minimal wiring effort due to the use of EB-DIK insertion bridges
- IP67 protected relay housing
- Cadmium-free relay contacts
- 4 kV electrical isolation of input and output
- Safe isolation in acc. with DIN EN 50178 (VDE 0160)
- Light indicator for signaling the switching state

Notes:		
Type of housing:	Polyamide PA, non-reinforced, color: green.	
Marking systems and mounting material	See Catalog 3	
For the protection of relay coils and contacts, inductive loads must be dampened with an efficient protection circuit.		
For additional EB...DIK... insertion bridges, refer to page 443		

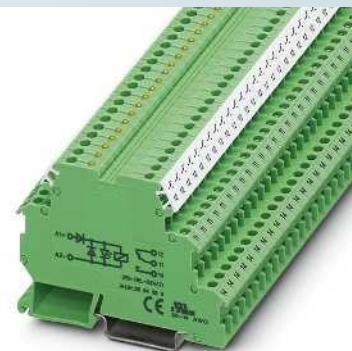

For medium to large power
1 PDT (21)

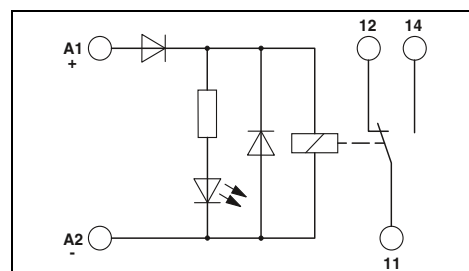

Technical data

Input data	①	
Permissible range (with reference to U_N)	0.8 - 1.1	
Typical input current at U_N	[mA]	9
Response/release time at U_N	[ms]	8 / 5
Input protection:	Yellow LED, reverse polarity protection, freewheeling diode	
Output data		
Contact type	1 PDT	
Contact material	AgSnO	
Max. switching voltage	250 V AC/DC	
Minimum switching voltage	12 V AC/DC	
Limiting continuous current	6 A	
Maximum switch-on current	6 A	
Minimum switching current	10 mA	
Maximum interrupting rating, ohmic load		
	24 V DC	140 W
	48 V DC	20 W
	60 V DC	18 W
	110 V DC	23 W
	220 V DC	40 W
	250 V AC	1500 VA
General data		
Test voltage (winding / contact)	4 kV AC (50 Hz, 1 min.)	
Ambient temperature (operation)	-20 °C ... 50 °C	
Mechanical service life	Approx. 10^7 cycles	
Standards/regulations	IEC 60664 , EN 50178	
Connection data solid/stranded/AWG	0.2 - 2.5 mm ² / 0.2 - 2.5 mm ² / 24 - 14	
Dimensions	W / H / D	6.2 mm / 80 mm / 56 mm
EMC note	Class A product, see page 605	

Ordering data

Description	Input voltage U_N	Type	Order No.	Pcs./ Pkt.
Relay terminal block with power relay	① 24 V DC	DEK-REL-G24/21	2964500	10

Accessories

Accessories	Order No.	Pcs./ Pkt.
D-DEK 1,5 GN	2716949	10
EB 80- DIK BU	26 A 2715940	1
EB 80- DIK RD	26 A 2715953	1
EB 80- DIK WH	26 A 2715788	1

Relay modules

Relay modules in terminal block design - DEK series

DEK-REL-24/1/SEN input interface and DEK-REL-24/1/AKT output interface

In addition to the familiar advantages of the DEK-REL... electronic terminal blocks, such as:

- 2-layer contact with hard gold-plating for universal applications from 1 mA to 5 A continuous current
- 2 kV_{rms} electrical isolation of input and output
- Integrated input circuit
With this terminal block, "ALL" connections for a sensor or actuator are provided in a width of just 6.2 mm.

This means that 16 outputs take up a total overall width of just 105.4 mm (including the power terminal).

Advantages:

- Lower costs as the N terminal block is no longer required
- Wiring is reduced to a minimum
- Space savings of up to 73%

Notes:	
Type of housing:	Polyamide PA, non-reinforced, color: green.
Marking systems and mounting material	See Catalog 3
For the protection of relay coils and contacts, inductive loads must be dampened with an efficient protection circuit.	
For additional EB...DIK... insertion bridges, refer to page 443	

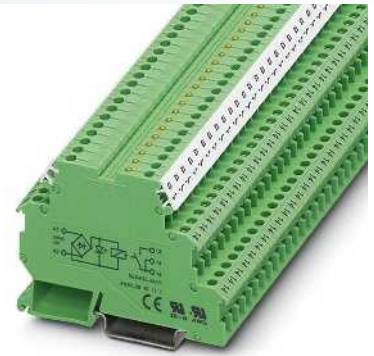

for small to medium loads
1 N/O contact (1)

ERC

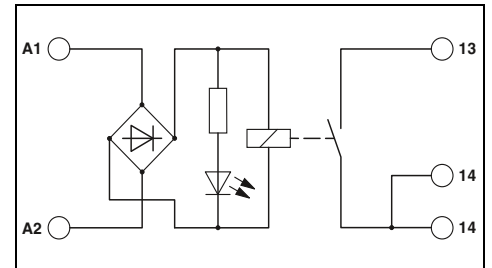

Technical data

Input data		①	②
Permissible range (with reference to U _N)		0.9 - 1.1	0.8 - 1.1
Typical input current at U _N	[mA]	23	6.5
Response/release time at U _N	[ms]	8 / 15	5 / 15
Input protection:		Yellow LED, bridge rectifier	
Output data			
Contact type		1 N/O contact (double contact)	
Contact material		AgNi, hard gold-plated	
Max. switching voltage		250 V AC / 125 V DC	
Minimum switching voltage		0.1 V	
Limiting continuous current		3 A (5 A up to 35°C at 24 V DC)	
Maximum switch-on current		5 A	
Minimum switching current		1 mA	
Maximum interrupting rating, ohmic load		24 V DC	72 W
		48 V DC	60 W
		60 V DC	50 W
		110 V DC	50 W
		250 V AC	750 VA
General data			
Test voltage (winding / contact)		2 kV AC (50 Hz, 1 min.)	
Ambient temperature (operation)		-20 °C ... 50 °C	
Mechanical service life		Approx. 2x 10 ⁷ cycles	
Standards/regulations		IEC 60664 , EN 50178	
Connection data solid/stranded/AWG		0.2 - 2.5 mm ² / 0.2 - 2.5 mm ² / 24 - 14	
Dimensions	W / H / D	6.2 mm / 80 mm / 56 mm	
EMC note		Class A product, see page 605	

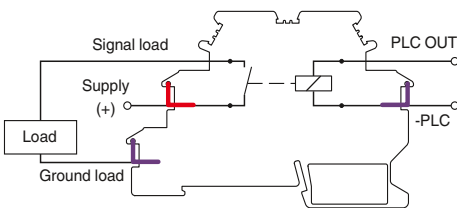

Pin configuration, DEK-REL...AKT

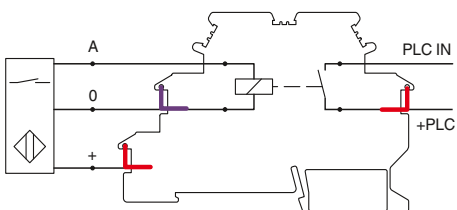

Pin configuration DEK-REL...SEN

Description	Input voltage U _N
Relay terminal block with miniature relay	
	① 5 V AC/DC
	② 24 V AC/DC

Terminal block, with three through contacts, for mounting on NS 35...

For busbar supply
Cover

Insertion bridge, for middle and lower levels	No. of pos.	Color
	80	blue
	80	red
	80	white

Ordering data

Type	Order No.	Pcs./ Pkt.
DEK-REL- 5/I/1	2941183	10
DEK-REL- 24/I/1	2940171	10

Accessories

D-DEK 1,5 GN		2716949	10
EB 80- DIK BU	26 A	2715940	1
EB 80- DIK RD	26 A	2715953	1
EB 80- DIK WH	26 A	2715788	1

Relay modules in terminal block design - DEK series

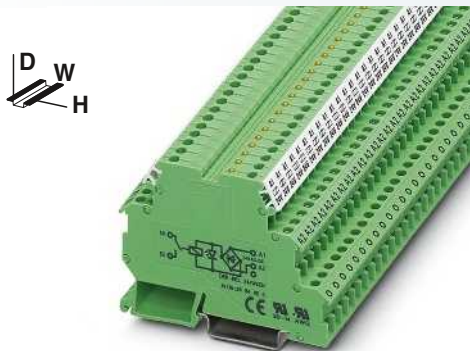

for small to medium loads
1 N/O contact (1)

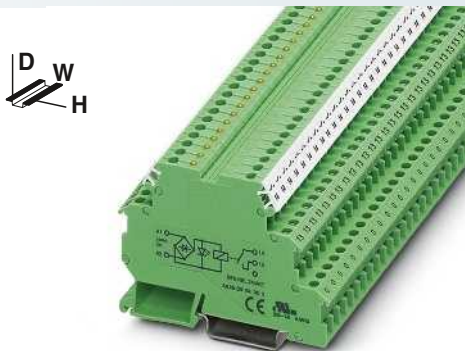

for small to medium loads
1 N/O contact (1)

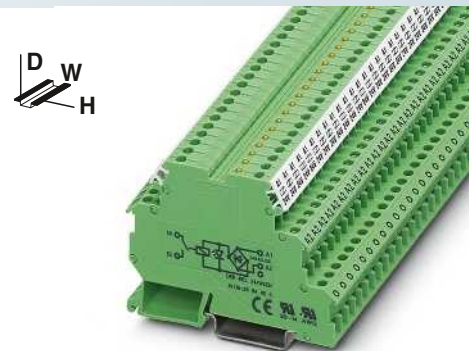

for small to medium loads
1 N/O contact (1)

ERC

ERC

ERC

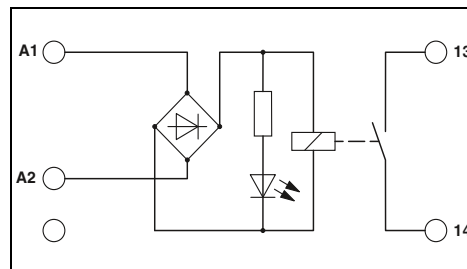
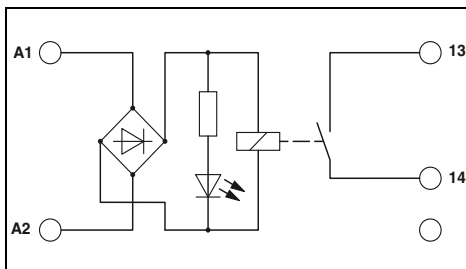
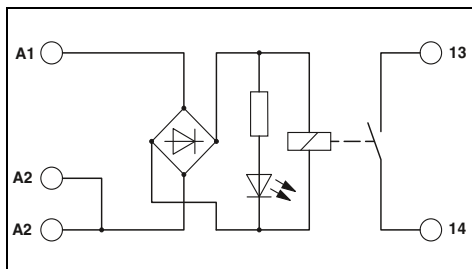

Technical data

Technical data

Technical data

① 0.9 - 1.1
23 6.5
8 / 15 5 / 15
Yellow LED, bridge rectifier

② 0.8 - 6.5
5 / 15
Yellow LED, bridge rectifier

② 0.8 - 6.5
5 / 15
Yellow LED, bridge rectifier

1 N/O contact (double contact)
AgNi, hard gold-plated
250 V AC / 125 V DC
0.1 V
3 A (5 A up to 35°C at 24 V DC)
5 A
1 mA

1 N/O contact
AgNi, hard gold-plated
250 V AC / 125 V DC
0.1 V
3 A (5 A up to 35°C at 24 V DC)
5 A
1 mA

1 N/O contact
AgNi, hard gold-plated
250 V AC / 125 V DC
0.1 V
3 A (5 A up to 35°C at 24 V DC)
5 A
1 mA

72 W
60 W
50 W
50 W
750 VA

72 W
60 W
50 W
50 W
750 VA

72 W
60 W
50 W
50 W
750 VA

2 kV AC (50 Hz, 1 min.)
-20 °C ... 50 °C
Approx. 2x 10⁷ cycles
IEC 60664 , EN 50178
0.2 - 2.5 mm² / 0.2 - 2.5 mm² / 24 - 14
6.2 mm / 80 mm / 56 mm
Class A product, see page 605

2 kV AC (50 Hz, 1 min.)
-20 °C ... 50 °C
Approx. 2x 10⁷ cycles
IEC 60664 , EN 50178
0.2 - 2.5 mm² / 0.2 - 2.5 mm² / 24 - 14
6.2 mm / 80 mm / 56 mm
Class A product, see page 605

2 kV AC (50 Hz, 1 min.)
-20 °C ... 50 °C
Approx. 2x 10⁷ cycles
IEC 60664 , EN 50178
0.2 - 2.5 mm² / 0.2 - 2.5 mm² / 24 - 14
6.2 mm / 80 mm / 56 mm
Class A product, see page 605

Ordering data

Ordering data

Ordering data

Type	Order No.	Pcs./ Pkt.
DEK-REL- 5/O/1	2941170	10
DEK-REL- 24/O/1	2941154	10

Type	Order No.	Pcs./ Pkt.
DEK-REL- 24/1/AKT	2964063	10

Type	Order No.	Pcs./ Pkt.
DEK-REL- 24/1/SEN	2964050	10

Accessories

Accessories

Accessories

D-DEK 1,5 GN	2716949	10
EB 80- DIK BU	26 A 2715940	1
EB 80- DIK RD	26 A 2715953	1
EB 80- DIK WH	26 A 2715788	1

DIKD 1,5	2715979	50
D-DEK 1,5 GN	2716949	10
EB 80- DIK BU	26 A 2715940	1
EB 80- DIK RD	26 A 2715953	1
EB 80- DIK WH	26 A 2715788	1

DIKD 1,5	2715979	50
D-DEK 1,5 GN	2716949	10
EB 80- DIK BU	26 A 2715940	1
EB 80- DIK RD	26 A 2715953	1
EB 80- DIK WH	26 A 2715788	1

Relay modules

Relay modules in terminal block design - DEK series

DEK-OE... and DEK-OV... solid-state relay terminal blocks

Phoenix Contact DEK-OE and DEK-OV interface terminal blocks are only 6.2 mm wide but still provide a complete input or output interface with:

- Electrical isolation between input and output at up to 2.5 kV_{rms}
- Integrated input circuit
- Status display
- EB-DIK insertion bridges
- Marking and mounting with terminal block convenience
- Wear-free switching up to 24 V DC/10 A and 240 V AC/800 mA
- Integrated output protection circuit
- Zero voltage switch at AC output
- Actuator version available

Notes:
Type of housing: Polyamide PA, non-reinforced, color: green.
Marking systems and mounting material See Catalog 3
For the protection of input and output, inductive loads must be dampened with an effective protection circuit.
For additional EB...DIK... insertion bridges, refer to page 443

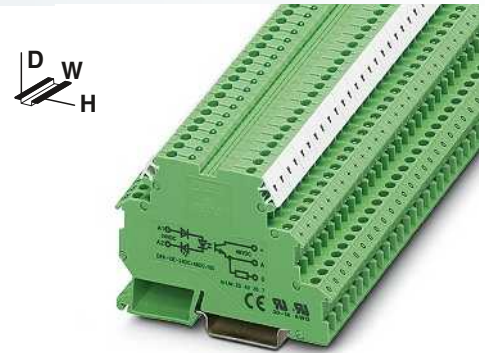

with DC voltage output
max. = 100 mA

ERC

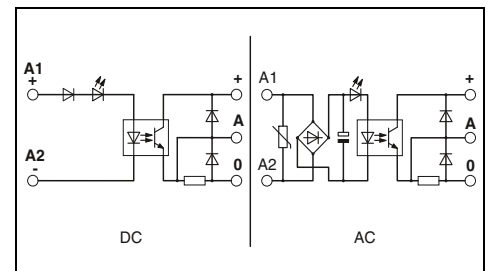

Derating curve for DEK-OV...24DC/3 and DEK-OV-24DC/24DC/3/AKT

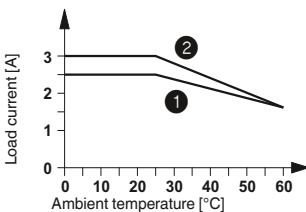

- 1 Horizontal mounting
- 2 Vertical mounting

Derating curve for DEK-OV-24DC/24DC/10

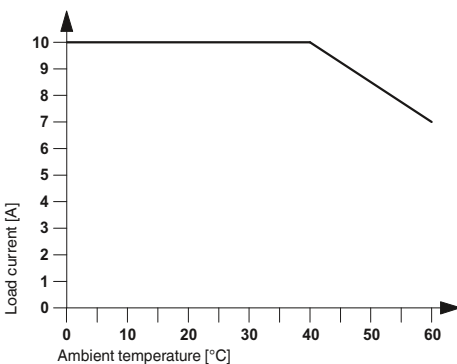

Derating curve for DEK-OV...240AC/800

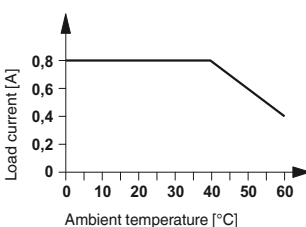

Input data	
Permissible range (with reference to U _N)	
Switching level with reference to U _N	1 signal ("H") ≥ 0.8 0 signal ("L") ≤ 0.4
Typical input current at U _N	[mA]
Transmission frequency f _{limit}	[Hz]
Input circuit AC	
Input circuit DC	
Output data	
Operating voltage range	3 V DC ... 48 V DC
Periodic peak reverse voltage	-
Limiting continuous current	100 mA
Minimum load current	-
Surge current	-
Leakage current in off state	-
Max. load value	-
Output protection	Reverse polarity protection, freewheeling diode
Voltage drop at maximum limiting continuous current	≤ 0.9 V
General data	
Test voltage input/output	2.5 kV (50 Hz, 1 min.)
Ambient temperature (operation)	-20 °C ... 60 °C
Standards/regulations	IEC 60664, EN 50178
Degree of pollution/surge voltage category	2 / III
Connection data solid/stranded/AWG	0.2 - 2.5 mm ² / 0.2 - 2.5 mm ² / 24 - 14
Dimensions	6.2 mm / 80 mm / 56 mm
EMC note	Class A product, see page 605

Technical data

①	②	③	④	⑤	⑥
0.9 - 1.1	0.8 - 1.2	0.8 - 1.2	0.8 - 1.2	0.9 - 1.1	0.9 - 1.1
≥ 0.8	≥ 0.8	≥ 0.8	≥ 0.8	≥ 0.8	≥ 0.9
≤ 0.4	≤ 0.4	≤ 0.4	≤ 0.4	≤ 0.4	≤ 0.4
6.5	11	7	4	3.2	2.5
300	300	300	300	3	3

Yellow LED, reverse polarity protection, surge protection
Yellow LED, reverse polarity protection

Description	Input voltage U _N
Solid-state input relays	
①	5 V DC
②	12 V DC
③	24 V DC
④	60 V DC
⑤	120 V AC
⑥	230 V AC
Solid-state power relays	
①	5 V DC
②	12 V DC
③	24 V DC
Actuator principle	⑦ 24 V DC

Ordering data

Type	Order No.	Pcs./Pkt.
DEK-OE- 5DC/ 48DC/100	2940223	10
DEK-OE- 12DC/ 48DC/100	2964487	10
DEK-OE- 24DC/ 48DC/100	2940207	10
DEK-OE- 60DC/ 48DC/100	2941536	10
DEK-OE-120AC/ 48DC/100	2941659	10
DEK-OE-230AC/ 48DC/100	2940210	10

Insertion bridge, for middle and lower levels	No. of pos.	Color
	80	blue
	80	red
	80	white

Accessories

Accessories	Order No.	Pcs./Pkt.
EB 80- DIK BU	26 A 2715940	1
EB 80- DIK RD	26 A 2715953	1
EB 80- DIK WH	26 A 2715788	1

Relay modules in terminal block design - DEK series



with DC voltage output
max. = 3 A

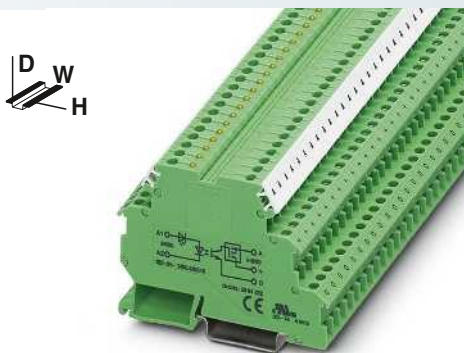

with DC voltage output
max. = 10 A



with AC voltage output
max. = 800 mA

ERC

ERC

ERC

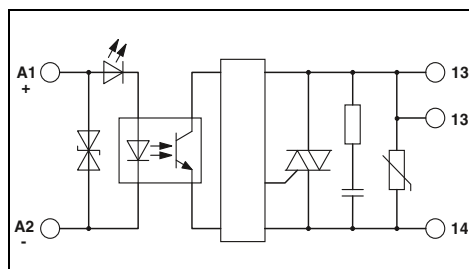
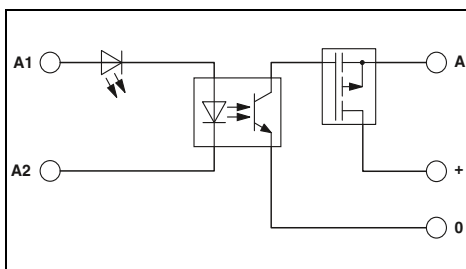
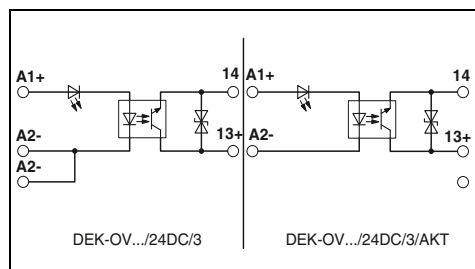

Technical data

Technical data

Technical data

①	②	③	⑦
0.8 - 1.2	0.8 - 1.2	0.8 - 1.2	0.8 - 1.2
≥ 0.8	≥ 0.8	≥ 0.8	≥ 0.8
≤ 0.4	≤ 0.4	≤ 0.4	≤ 0.4
11	8.5	7	7
300	300	300	300

①	②	③
0.8 - 1.2	0.8 - 1.2	0.8 - 1.2
≥ 0.8	≥ 0.8	≥ 0.8
≤ 0.4	≤ 0.4	≤ 0.4
5.1	4.7	3.5
100	100	100

①	②	③
0.8 - 1.2	0.8 - 1.2	0.8 - 1.2
≥ 0.8	≥ 0.8	≥ 0.8
≤ 0.4	≤ 0.4	≤ 0.4
10.2	10.5	10.7
10	10	10

Yellow LED, reverse polarity protection

Yellow LED, reverse polarity protection, surge protection

Yellow LED, reverse polarity protection, surge protection

3 V DC ... 30 V DC

5 V DC ... 30 V DC

10 V AC ... 253 V AC (50/60 Hz)

3 A (see derating curve)

10 A (see derating curve)

0.8 A (see derating curve)

Reverse polarity protection, surge protection
≤ 0.2 V

Reverse polarity protection, surge protection
< 50 mV

RCV circuit
≤ 1 V

2.5 kV (50 Hz, 1 min.)
-20 °C ... 60 °C
IEC 60664 , EN 50178
2 / III
0.2 - 2.5 mm² / 0.2 - 2.5 mm² / 24 - 14
6.2 mm / 80 mm / 56 mm
Class A product, see page 605

2.5 kV (50 Hz, 1 min.)
-20 °C ... 60 °C
IEC 60664 , EN 50178
2 / III
0.2 - 2.5 mm² / 0.2 - 2.5 mm² / 24 - 14
6.2 mm / 80 mm / 56 mm
Class A product, see page 605

2.5 kV (50 Hz, 1 min.)
-20 °C ... 60 °C
IEC 60664 , EN 50178
2 / III
0.2 - 4 mm² / 0.2 - 2.5 mm² / 24 - 12
6.2 mm / 80 mm / 56 mm

Ordering data

Ordering data

Ordering data

Type	Order No.	Pcs./ Pkt.
DEK-OV- 5DC/ 24DC/ 3	2941361	10
DEK-OV- 12DC/ 24DC/ 3	2941387	10
DEK-OV- 24DC/ 24DC/ 3	2941374	10
DEK-OV- 24DC/ 24DC/ 3/AKT	2964296	10

Type	Order No.	Pcs./ Pkt.
DEK-OV- 5DC/ 24DC/ 10	2961752	10
DEK-OV- 12DC/ 24DC/ 10	2961749	10
DEK-OV- 24DC/ 24DC/ 10	2964322	10

Type	Order No.	Pcs./ Pkt.
DEK-OV- 5DC/240AC/800	2964623	10
DEK-OV- 12DC/240AC/800	2964636	10
DEK-OV- 24DC/240AC/800	2964649	10

Accessories

Accessories

Accessories

Type	Order No.	Pcs./ Pkt.
EB 80- DIK BU	26 A 2715940	1
EB 80- DIK RD	26 A 2715953	1
EB 80- DIK WH	26 A 2715788	1

Type	Order No.	Pcs./ Pkt.
EB 80- DIK BU	26 A 2715940	1
EB 80- DIK RD	26 A 2715953	1
EB 80- DIK WH	26 A 2715788	1

Type	Order No.	Pcs./ Pkt.
EB 80- DIK BU	26 A 2715940	1
EB 80- DIK RD	26 A 2715953	1
EB 80- DIK WH	26 A 2715788	1



DEK-REL-24/1/S switch/relay terminal block

The “Manual”, “0”, and “Automatic” functions are performed in a relay terminal block that is just 6.2 mm wide.

Interference-free relay and solid-state relay interfaces

Coupled interference voltages on the coil lines or leakage currents can cause malfunctions in conventional modules. These special interface modules, equipped with high switching thresholds and/or effective filters, ensure good functioning.

ST-REL... and EMG 17-REL... relay interfaces for switching lamp loads

Lamp loads and capacitive loads produce extremely high inrush currents which weld conventional relay contacts. To prevent this, Phoenix Contact uses an arc-resistant contact optimized for these applications, which keeps these peaks under control.

ST-OV 3-24DC/400/3 plug-in solid-state power relays

The output of this component, dimensioned with a peak reverse voltage of 800 V, allows, for example, 230 V motors to be driven in simple reversible mode.

Power circuit breaker solid-state relay, with signal logic

These modules combine the features of a short-circuit-proof power solid-state relay and those of a thermomagnetic protection element.

DEK-OE-...100KHZ 100 kHz input solid-state relay

Input solid-state relay for reliable transmission of high-frequency signals, such as those that occur with incremental encoders, for example.

Electronic sensor terminal block for NAMUR proximity sensors

For converting the changeable resistance of a NAMUR sensor into a digital signal that can be read by a PLC.

DEK-TR/INV inverter module

Module for converting NPN outputs to PNP outputs and PNP to NPN.

Relay module with manual switch

Relay module with manual switch and integrated power relay for manual, zero, and automatic functions

The advantages:

- Maximum switching current of 5 A
- Only 6.2 mm wide
- Increased contact stability thanks to double contact
- Safe isolation according to DIN EN 50178 between coil and contact

Notes:
Type of housing: Polyamide PA, non-reinforced, color: green.
Marking systems and mounting material See Catalog 3
For the protection of input and output, inductive loads must be damped with an effective protection circuit.

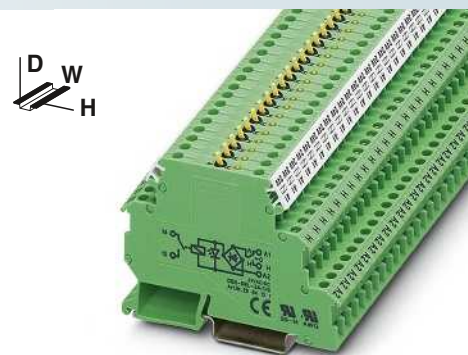

Relay module with manual switch and integrated relay

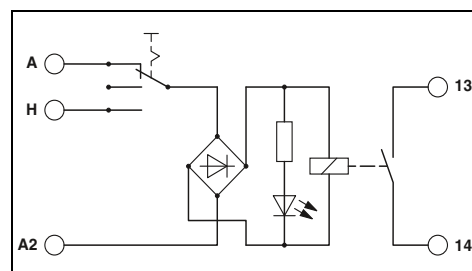

Technical data

Input data	①
Permissible range (with reference to U_N)	0.8 - 1.1
Typical input current at U_N [mA]	6.5
Response/release time at U_N [ms]	5 / 15
Input protection:	Yellow LED, bridge rectifier
Output data	
Contact type	1 N/O contact
Contact material	AgNi, hard gold-plated
Max. switching voltage	250 V AC / 125 V DC
Minimum switching voltage	0.1 V
Limiting continuous current	3 A (5 A up to 35°C at 24 V DC)
Maximum switch-on current	5 A
Minimum switching current	1 mA
Maximum interrupting rating, ohmic load	
	24 V DC 72 W
	48 V DC 60 W
	60 V DC 50 W
	110 V DC 50 W
	250 V AC 750 VA
General data	
Test voltage (winding / contact)	2 kV AC (50 Hz, 1 min.)
Ambient temperature (operation)	-20 °C ... 50 °C
Mechanical service life	Approx. 2x 10 ⁷ cycles
Standards/regulations	IEC 60664 , EN 50178
Connection data solid/stranded/AWG	0.2 - 2.5 mm ² / 0.2 - 2.5 mm ² / 24 - 14
Dimensions	W / H / D 6.2 mm / 80 mm / 61 mm
EMC note	Class A product, see page 605

Ordering data

Description	Input voltage U_N	Type	Order No.	Pcs./Pkt.
Relay module with power relay	① 24 V AC/DC	DEK-REL- 24/1/S	2964131	10

Accessories

Cover	No. of pos.	Color	D-DEK 1,5 GN	2716949	10
Insertion bridge	2	red	EB 2- DIK RD	2716693	10
	3	red	EB 3- DIK RD	2716745	10
	4	red	EB 4- DIK RD	2716758	10
	5	red	EB 5- DIK RD	2716761	10
	10	red	EB 10- DIK RD	2716774	10
	2	blue	EB 2- DIK BU	2716648	10
	3	blue	EB 3- DIK BU	2716651	10
	4	blue	EB 4- DIK BU	2716664	10
	5	blue	EB 5- DIK BU	2716677	10
	10	blue	EB 10- DIK BU	2716680	10
	80	blue	EB 80- DIK BU	2715940	1
	80	red	EB 80- DIK RD	2715953	1

Relay modules

Special relays and solid-state relays

Relay modules with interference current filter

Relay and solid-state relay modules with integrated filter to protect against interference voltages or currents due, for example, to long control lines

The advantages:

- Resistant to interference currents
- High relay release voltage

Typical applications:

- Applications with long control lines
- Use of AC output boards, resulting in residual AC currents



1-PDT plug-in relay



1-PDT soldered-in relay

Notes:
Load current diagrams, see page 401

ERC

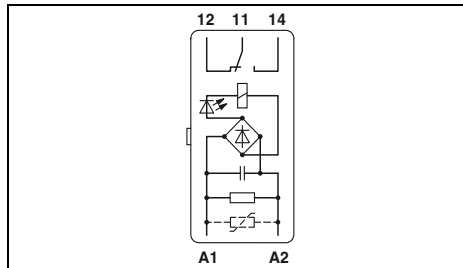

Technical data

Input data			
Permissible range (with reference to U_N)	①	②	③
Typical input current at U_N	0.9 - 1.1	0.85 - 1.1	0.9 - 1.1
Response/release time at U_N	26	19	18
Input protection:	8 / 10	8 / 11	10 / 8

Technical data			
①	②	③	
0.9 - 1.1	0.85 - 1.1	0.9 - 1.1	
26	19	18	
8 / 10	8 / 11	10 / 8	
Yellow LED, bridge rectifier, surge protection			

ERC

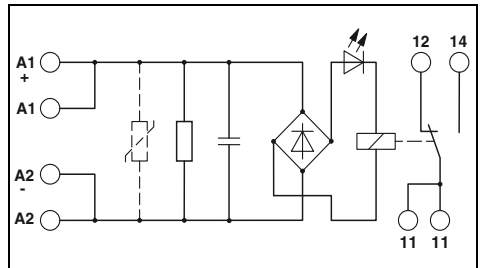

Technical data

Input data		
Permissible range (with reference to U_N)	③	
Typical input current at U_N	0.9 - 1.1	
Response/release time at U_N	18	
Input protection:	10 / 8	

Technical data		
③		
0.9 - 1.1		
18		
10 / 8		
Yellow LED, bridge rectifier, surge protection		

Output data	
Contact type	
Contact material	
Max. switching voltage	
Limiting continuous current	
Maximum switch-on current	
Maximum interrupting rating, ohmic load	
	24 V DC 140 W
	48 V DC 60 W
	60 V DC 45 W
	110 V DC 35 W
	220 V DC 55 W
	250 V AC 1500 VA

Technical data	
Single contact, 1-PDT	Double contact, 1-PDT
AgNi	Au
250 V AC/DC	30 V AC / 36 V DC
6 A	0.5 A
8 A	0.2 A
	5 W
	-
	-
	-
	-
	-
	-

Technical data	
Single contact, 1-PDT	Double contact, 1-PDT
AgNi	AgPd60, hard gold-plated
250 V AC/DC	30 V AC / 36 V DC
6 A	0.5 A
8 A	0.2 A
	5 W
	-
	-
	-
	-
	-
	-
	-

General data	
Test voltage (winding / contact)	2.5 kV AC (50 Hz, 1 min.)
Ambient temperature (operation)	-20 °C ... 50 °C
Mechanical service life	Approx. 2x 10 ⁷ cycles
Standards/regulations	IEC 60664, EN 50178
Connection data solid/stranded/AWG	- / - / -
Dimensions	20.8 mm / 42.5 mm / 112 mm
EMC note	

General data	
Test voltage (winding / contact)	2.5 kV AC (50 Hz, 1 min.)
Ambient temperature (operation)	-20 °C ... 40 °C
Mechanical service life	Approx. 2x 10 ⁷ cycles
Standards/regulations	IEC 60664, EN 50178
Connection data solid/stranded/AWG	0.2 - 4 mm ² / 0.2 - 2.5 mm ² / 24 - 12
Dimensions	22.5 mm / 75 mm / 62.5 mm
EMC note	Class A product, see page 605

General data	
Test voltage (winding / contact)	2.5 kV AC (50 Hz, 1 min.)
Ambient temperature (operation)	-20 °C ... 40 °C
Mechanical service life	Approx. 2x 10 ⁷ cycles
Standards/regulations	IEC 60664, EN 50178
Connection data solid/stranded/AWG	0.2 - 4 mm ² / 0.2 - 2.5 mm ² / 24 - 12
Dimensions	22.5 mm / 75 mm / 62.5 mm
EMC note	Class A product, see page 605

Ordering data	
Description	Input voltage U_N
Relay module with power contact relay	
	① 24 V AC
	② 120 V AC
	③ 230 V AC
Relay module with multi-layer contact relay	
	① 24 V AC
	② 120 V AC
	③ 230 V AC

Ordering data		
Type	Order No.	Pcs./ Pkt.
ST-REL3-KG 24/21/SO46	2826091	10
ST-REL3-KG120/21/SO46	2833026	10
ST-REL3-KG230/21/SO46	2832027	10
ST-REL3-KG 24/21/AU/SO46	2826981	10
ST-REL3-KG120/21/AU/SO46	2829797	10
ST-REL3-KG230/21/AU/SO46	2826266	10

Ordering data		
Type	Order No.	Pcs./ Pkt.
EMG 22-REL/KSR-230/21/ SO46	2940760	10
EMG 22-REL/KSR-230/21/AU/SO46	2940061	10

Accessories	
Basic terminal block, complete with end cover	
Equipment marker	

Accessories		
URELG 3	2820136	10

Accessories		
EMG-GKS 12	2947035	50

Notes:	
Type of housing:	ST-REL: polyamide PA, non-reinforced, color: bottom part gray, hood green
	EMG: polyamide PA-F, fiber-reinforced, color: green
	DEK: polyamide PA, non-reinforced, color: green
Marking systems and mounting material See Catalog 3	
For derating curve, refer to page 399	

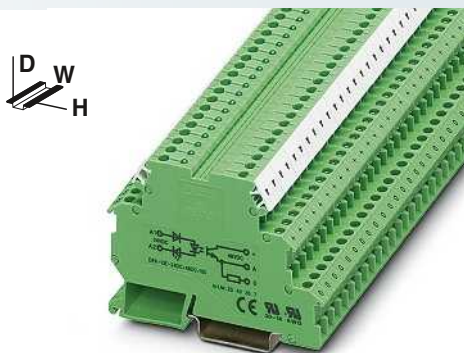

Solid-state input relay
100 mA, maximum



Solid-state power relay
Max. 2 A

ERC

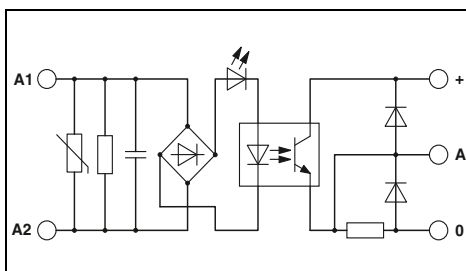

Technical data

Input data	②
Permissible range (with reference to U_N)	0.9 - 1.1
Switching level	1 signal ("H") [V DC] \geq 207 0 signal ("L") [V DC] \leq 92
Typical input current at U_N	[mA] 2.5
Typical switch-on time at U_N	[ms] 4.4
Typical switch-off time at U_N	[ms] 14
Transmission frequency f_{limit}	[Hz] 5
Input circuit AC	Yellow LED, surge protection, RC element

Input circuit DC	
Output data	
Max. switching voltage	48 V DC
Minimum switching voltage	3 V DC
Limiting continuous current	100 mA
Maximum switch-on current	-
Output circuit	3-conductor, ground-referenced
Output protection	Reverse polarity protection, free running
Voltage drop at maximum limiting continuous current	≤ 0.9 V

General data	
Test voltage input/output	2.5 kV AC
Ambient temperature (operation)	0 °C ... 50 °C
Standards/regulations	IEC 60664 , EN 50178
Degree of pollution/surge voltage category	2 / III

Mounting position/mounting	any / In rows with zero spacing
----------------------------	---------------------------------

Connection data solid/stranded/AWG	0.2 - 2.5 mm ² / 0.2 - 2.5 mm ² / 24 - 12
Dimensions	W / H / D 6.2 mm / 80 mm / 56 mm

EMC note

Description	Input voltage U_N
Solid-state power relays	
	① 24 V DC
	② 230 V AC

Equipment marker

ERC

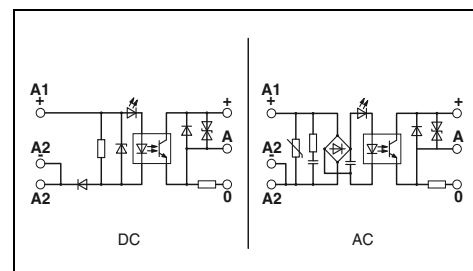

Technical data

①	0.8 - 1.2
	16.8
	16
	8
	0.02
	0.2
	300

Reverse polarity protection

48 V DC
12 V DC
2 A (see derating curve)
5 A ($t = 1$ s)
3-conductor, ground-referenced
Reverse polarity protection, surge protection
1.1 V

3.5 kV AC
-10 °C ... 55 °C
IEC 60664 , EN 50178
2 / III

- / Mounted in rows with zero spacing: Horizontal/not in rows: Any

0.2 - 4 mm ² / 0.2 - 2.5 mm ² / 24 - 12
17.5 mm / 75 mm / 102 mm
Class A product, see page 605

EMC note

Description	Input voltage U_N
Solid-state power relays	
	① 24 V DC
	② 230 V AC

Equipment marker

Ordering data		
Type	Order No.	Pcs./ Pkt.
DEK-OE-230AC/ 48DC/100/SO 46	2964678	10

Accessories		

Ordering data		
Type	Order No.	Pcs./ Pkt.
EMG 17-OV- 24DC/ 48DC/2	2942810	10

Accessories		
EMG-GKS 12	2947035	50

Relay modules

Special relays and solid-state relays

Relay modules for high inrush currents

The Phoenix Contact relay modules of type SO 38 have been designed for switching electrical equipment with high inrush currents.

Areas of application include:

- Inductive loads (motors, power contactors etc.)
- Inductive/capacitive loads (fluorescent lamps, etc.)
- Ohmic loads (glow lamps, heaters)

The module is based on a relay with a special arc-resistant tungsten lead contact. This takes over the high inrush and interrupting current capacitively. The inductive main contact made of AgCdO takes over the continuous current up to 10 A reliably. With the EMG 17-REL...2E/SO38, this switching capacity is reached using a power relay with a set of silver tin oxide (AgSnO) contacts.

The module is available in two versions:

- Modular EMG housing that can be mounted on a DIN rail, with an overall width of 17.5 mm
- Convenient ST-REL plug-in housing from the Phoenix ST series for mounting on URELG or UDK-RELG basic terminal blocks

Other features include:

- Snap-on mounting on the common EN DIN rails
- Easy maintenance
- Clear marking of the terminal blocks using Phoenix Contact marking material

Notes:
Type of housing: Polycarbonate PC-F, fiber-reinforced, color: green or black.
Marking systems and mounting material See Catalog 3

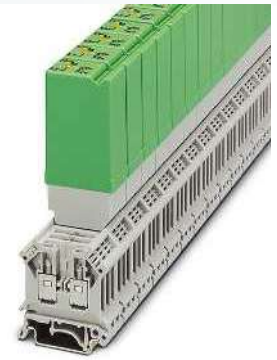

medium to large powers
1 N/O contact (1)

ERC

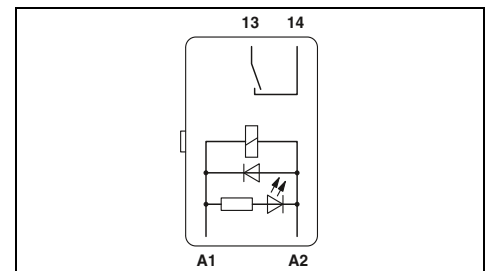

Technical data

Input data	①
Permissible range (with reference to U_N)	0.85 - 1.1
Typical input current at U_N	28 [mA]
Response/release time at U_N	13 / 15 [ms]
Input protection:	Yellow LED, freewheeling diode
Output data	
Contact type	1 N/O contact with lead contact
Contact material	AgCdO
Max. switching voltage	250 V AC
Limiting continuous current	10 A
Maximum switch-on current	80 A (20 ms)
Maximum interrupting rating, ohmic load	
	24 V DC -
	48 V DC -
	60 V DC -
	110 V DC -
	220 V DC -
	250 V AC 2500 VA
General data	
Test voltage (winding / contact)	2.5 kV AC (50 Hz, 1 min.)
Ambient temperature (operation)	-20 °C ... 50 °C
Mechanical service life	Approx. 10 ⁷ cycles
Standards/regulations	IEC 60664 , EN 50178
Mounting position/mounting	- / Horizontal with zero spacing, vertical with spacing
Connection data solid/stranded/AWG	-
Dimensions	W / H / D 20.8 mm / 42.5 mm / 112 mm
EMC note	

Ordering data

Description	Input voltage U_N	Type	Order No.	Pcs./ Pkt.
Relay module with power contact relay + wolfram lead contact				
	① 24 V DC	ST-REL3-KG 24/ 1/SO38	2829564	10
Relay module with power contact relay, with two inputs for manual, automatic	① 24 V DC			

Accessories

Basic terminal block, complete with end cover	URELG 3	2820136	10
Equipment marker			



medium to large powers
1 N/O contact (1)

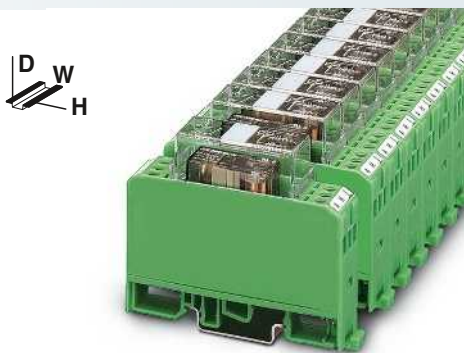

medium to large powers
1 N/O contact (1)

ERIC

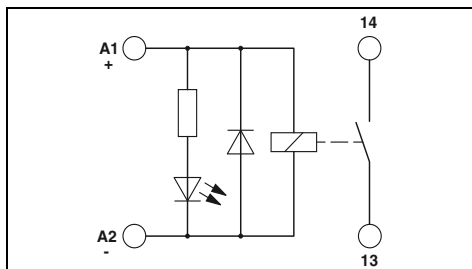

Technical data

①
0.85 -
1.1
28
13 /
15
Yellow LED, freewheeling diode

1 N/O contact with lead contact
AgCdO
250 V AC
10 A
80 A (20 ms)

-
-
-
-
-
2500 VA

4 kV AC (50 Hz, 1 min.)
-20 °C ... 50 °C
Approx. 10⁷ cycles
IEC 60664 , EN 50178
any

0.2 - 4 mm² / 0.2 - 2.5 mm² / 24 - 12
17.5 mm / 75 mm / 62.5 mm
Class A product, see page 605

Ordering data

Type	Order No.	Pcs./ Pkt.
EMG 17-REL/KSR-G 24/SO38 BK	2949994	10

Accessories

EMG-GKS 12	2947035	50
------------	---------	----

ERIC

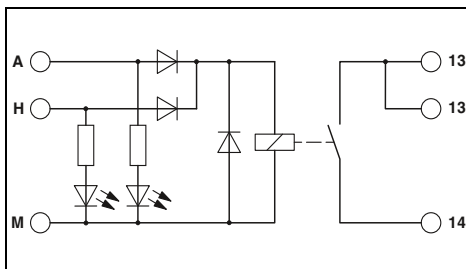

Technical data

①
0.9 -
1.1
23
9 / 10
Automatic: Yellow LED, Manual: Red LED, freewheeling diode, reverse polarity protection

Single contact, 1 N/O contact
AgSnO
250 V AC/DC
10 A
120 A (20 ms)

240 W
120 W
85 W
70 W
90 W
2500 VA

4 kV AC (50 Hz, 1 min.)
-20 °C ... 50 °C
3 x 10⁷ cycles
IEC 60664 , EN 50178
any

0.2 - 4 mm² / 0.2 - 2.5 mm² / 24 - 12
17.5 mm / 75 mm / 62.5 mm
Class A product, see page 605

Ordering data

Type	Order No.	Pcs./ Pkt.
EMG 17-REL/KSR-G 24/2E/SO38	2941646	10

Accessories

EMG-GKS 12	2947035	50
------------	---------	----

Relay modules

Special relays and solid-state relays

Plug-in solid-state power relays ST-OV 3

The plug-in version of the module provides all the advantages of the ST series, such as:

- Switching of up to 400 V AC/3 A
- Control of 230 V motors in straightforward reversing mode (e.g., synchronous motor in single-phase operation, see illustration)
- Plug-in design

Notes:	
Type of insulating housing: polyamide PA, non-reinforced, color: bottom part gray, hood green	
Ground (minus) potential from the input and output of the optocoupler should not be connected.	
AC loads must be protected with a varistor or an RC element.	



with AC voltage output
max. = 3 A

ERC

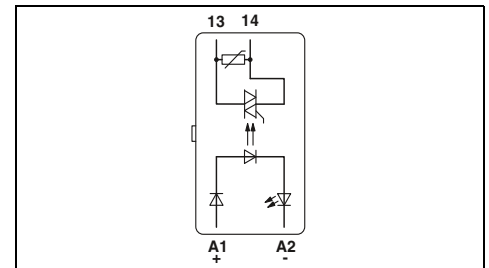

Technical data

Input data		①
Switching level with reference to U_N	1 signal ("H")	≥ 0.8
	0 signal ("L")	≤ 0.4
Typical input current at U_N		[mA] 7
Transmission frequency f_{limit}		[Hz] 10
Input protection:		Yellow LED, reverse polarity protection, RC element
Output data		
Operating voltage		400 V AC
Operating voltage range		24 V AC ... 420 V AC
Periodic peak reverse voltage		800 V
Limiting continuous current		3 A (see derating curve)
Minimum load current		50 mA
Surge current		125 A ($t = 10$ ms)
Residual voltage drop at "H"		≤ 1.2 V
Leakage current in off state		approx. 12 mA
Output protection		Surge protection, RC element
General data		
Test voltage input/output		2.5 kV AC
Ambient temperature (operation)		0 °C ... 60 °C
Standards/regulations		IEC 60664, EN 50178
Degree of pollution/surge voltage category		2 / III
Mounting position/mounting		Horizontal DIN rail / -
Dimensions	W / H / D	20.8 mm / 42.5 mm / 112 mm

Ordering data

Description	Input voltage U_N	Type	Order No.	Pcs./Pkt.
Solid-state power relays	① 24 V DC	ST-OV3- 24DC/400AC/3	2905417	10

Accessories

Basic terminal block, complete with end cover	URELG 3	2820136	10
---	---------	---------	----

Derating curve for ST-OV 3-24DC/400AC/3

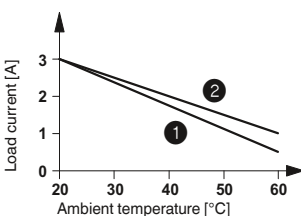

- ① Aligned without spacing
- ② Aligned with ≥ 20 mm spacing

Power circuit breaker solid-state relay with signal logic ST-OV 4-24DC/24DC/...-PRO

The ST-OV 4-...PRO provides protection and monitoring functions that are otherwise only known from thermomagnetic protection elements.

The PROtect modules have the following features:

- Fast short-circuit shutdown and simultaneous current limitation
- Time-dependent overload shutdown for reliable protection against continuous overloads
- Brief inrush peaks are ignored
- After an overload or short circuit has been triggered, a defined reset of the control voltage must be carried out
- Reliable recognition and indication of an open circuit on the load side
- Feedback in the event of an error

Notes:	
Type of housing:	Polyamide PA, non-reinforced, color: bottom part gray, hood green
Marking systems and mounting material	See Catalog 3
For load current diagram, see page 401	
Derating curve, time/current characteristic curves, and state diagram, see page 401	

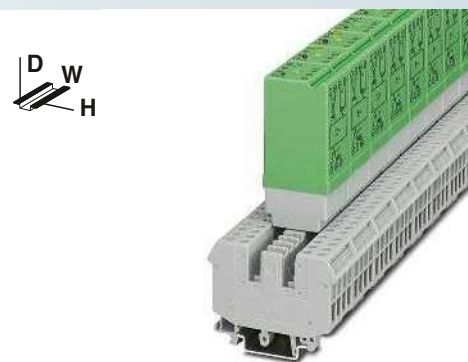

with short-circuit-proof DC voltage output max. = 1 A or 4 A

ERIC

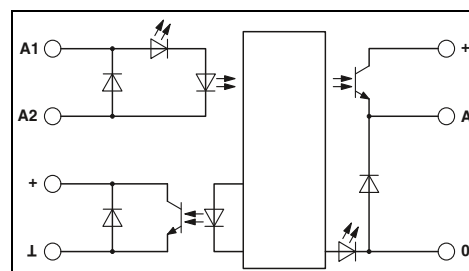

Technical data

Input data	ST-OV4- 24DC/ 24DC/1-PRO	ST-OV4- 24DC/ 24DC/4-PRO
Operating voltage	24 V DC	24 V DC
Switching level	8.5 V DC	5 V DC
Typical input current at U_N	6.5 mA	6.5 mA
Transmission frequency f_{limit}	100 Hz	100 Hz
Reset duration after short circuit/overload cut-off	1 ms	1 ms
Input circuit	Yellow LED, polarity protection diode	
Output data signaling contact / CONTROL		
Operating voltage range	5 V DC ... 36 V DC	
Limiting continuous current	50 mA	
Residual voltage drop at "H"	≤ 1.5 V	
Output protection	Polarity protection diode	
Output circuit	3-conductor, ground-referenced	
Output data load contact		
Operating voltage range	18 V DC ... 36 V DC	
Limiting continuous current	1 A (see derating curve)	4 A (see derating curve)
Minimum load current	1 mA	
Residual voltage drop at "H"	300 mV	200 mV
Open circuit alarm with load current	< 100 μ A	
Overload disconnection (~ 1.4 x continuous current)	≤ 100 ms (See the time-current characteristic curve)	
Short-circuit disconnection	< 200 μ s (See the time-current characteristic curve)	
Current limitation at short-circuits	approx. 25 A	approx. 70 A
Switching time t_{in} / t_{out}	300 μ s / 700 μ s	
Output protection	Red LED, Damping diode	
Output circuit	3-conductor, ground-referenced	
General data		
Test voltage input/output	2.5 kV AC	
Test voltage output/output	2.5 kV AC	
Rated surge voltage	Basic insulation	
Ambient temperature (operation)	0 °C ... 60 °C	
Standards/regulations	IEC 60664 / EN 50178	
Screw connection solid/stranded/AWG	0.2 - 4 mm ² / 0.2 - 4 mm ² / 24 - 12	
Dimensions	W / H / D 27 mm / 63.5 mm / 114 mm	

Ordering data

Description	Output current	Type	Order No.	Pcs./ Pkt.
Power circuit breaker solid-state relay, with signal logic	1 A	ST-OV4- 24DC/ 24DC/1-PRO	2905572	10
	4 A	ST-OV4- 24DC/ 24DC/4-PRO	2905585	10

Accessories

Basic terminal block, complete with end cover	UDK-RELG 4	2777056	10
--	------------	---------	----

Relay modules

Special relays and solid-state relays

100 kHz input solid-state relay DEK-OE

A solid-state relay for the reliable detection of short pulses

- Limit frequency of up to 100 kHz
- Push-pull stage on output side
- Includes signal inputs on PLC counter boards
- Features a capacitor on the input side for interference suppression

Notes:
Type of housing: Polyamide PA, non-reinforced, color: green.
Marking systems and mounting material See Catalog 3

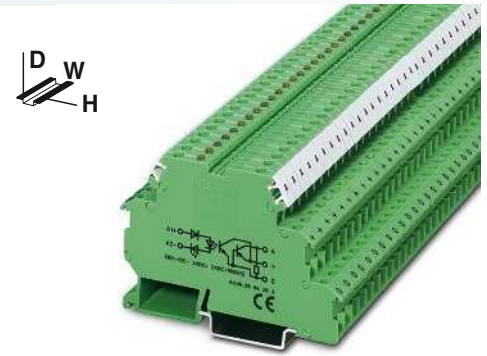

With DC voltage output
Transmission frequency 100 kHz

ERC

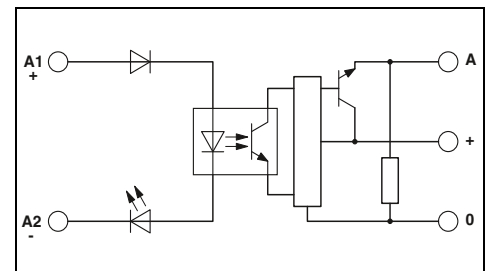

Technical data

Input data		①	②
Permissible range (with reference to U_N)		0.8 - 1.2	0.8 - 1.2
Switching level with reference to U_N	1 signal ("H")	≥ 0.8	≥ 0.8
	0 signal ("L")	≤ 0.4	≤ 0.4
Typical input current at U_N	[mA]	7	6
Typical switch-on time at U_N	[μ s]	1.5	1.5
Typical switch-off time at U_N	[μ s]	2	2
Transmission frequency f_{limit}	[kHz]	100	100
Input protection:		Yellow LED, reverse polarity protection, surge protection	
Output data			
Operating voltage range		4 V DC ... 30 V DC	
Limiting continuous current		50 mA	
Quiescent current		4.3 mA	
Residual voltage drop at "H"		≤ 0.5 V DC	
Output circuit		3-conductor, ground-referenced	
Output protection		Surge protection	
General data			
Test voltage input/output		2.5 kV AC	
Ambient temperature (operation)		-20 °C ... 60 °C	
Standards/regulations		IEC 60664 , EN 50178	
Degree of pollution/surge voltage category		2 / II	
Connection data solid/stranded/AWG		0.2 - 4 mm ² / 0.2 - 2.5 mm ² / 24 - 12	
Dimensions	W / H / D	6.2 mm / 80 mm / 56 mm	
EMC note		Class A product, see page 605	

Ordering data

Description	Input voltage U_N	Type	Order No.	Pcs./ Pkt.
Solid-state input relays	① 5 V DC	DEK-OE- 5DC/ 24DC/100KHZ	2964270	10
	② 24 V DC	DEK-OE- 24DC/ 24DC/100KHZ	2964283	10



With DC voltage output push-pull
Transmission frequency 100 kHz



With DC voltage output push-pull
Transmission frequency 100 kHz

ERC

ERC

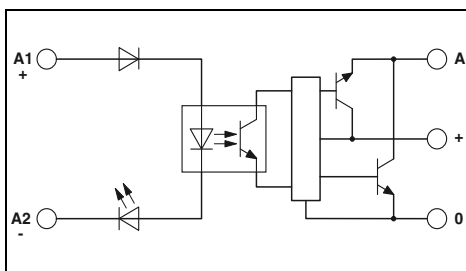
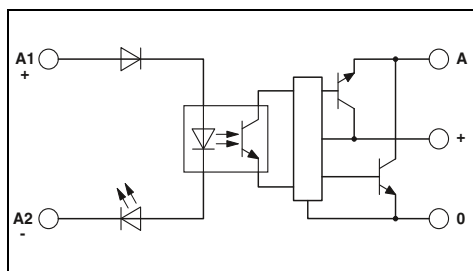

Technical data

Technical data

①	②
0.5 - 1.2	0.8 - 1.2
≥ 0.5	≥ 0.8
≤ 0.3	≤ 0.4
8	8
1	1
2	2
100	100

Yellow LED, reverse polarity protection, surge protection

①	②
0.5 - 1.2	0.8 - 1.2
≥ 0.5	≥ 0.8
≤ 0.3	≤ 0.4
8	8
1	1
2	2
100	100

Yellow LED, reverse polarity protection, surge protection

4 V DC ... 18 V DC
50 mA
8.5 mA
≤ 1.2 V DC
3-conductor push-pull, ground referenced
Surge protection

14 V DC ... 30 V DC
50 mA
15 mA
≤ 2.2 V DC
3-conductor push-pull, ground referenced
Surge protection

2.5 kV AC
-20 °C ... 60 °C
IEC 60664 , EN 50178
2 / II

2.5 kV AC
-20 °C ... 60 °C
IEC 60664 , EN 50178
2 / II

0.2 - 4 mm² / 0.2 - 2.5 mm² / 24 - 12
6.2 mm / 80 mm / 56 mm
Class A product, see page 605

0.2 - 4 mm² / 0.2 - 2.5 mm² / 24 - 12
6.2 mm / 80 mm / 56 mm
Class A product, see page 605

Ordering data

Ordering data

Type	Order No.	Pcs./ Pkt.
DEK-OE- 5DC/ 5DC/100KHZ-G	2964542	10
DEK-OE- 24DC/ 5DC/100KHZ-G	2964364	10

Type	Order No.	Pcs./ Pkt.
DEK-OE- 5DC/ 24DC/100KHZ-G	2964555	10
DEK-OE- 24DC/ 24DC/100KHZ-G	2964348	10

Relay modules

Special relays and solid-state relays

Electronic sensor terminal block for NAMUR proximity sensors

The EIK 1-SVN 24-P electronic sensor terminal block from Phoenix converts the changeable resistance of a NAMUR sensor unit into a digital signal that can be read by all PLCs.

- Monitoring of initiator side for short circuits or strand breaks
- Suitable resistance circuit to enable monitoring of mechanical switches (see application 2)
- LED error display
- Status display (high signal) via green LED
- 24 V/50 mA digital output
- Bridging and marking with standard terminal accessories.

Notes:
Type of housing: Polyamide PA, non-reinforced, color: green.
Marking systems and mounting material See Catalog 3

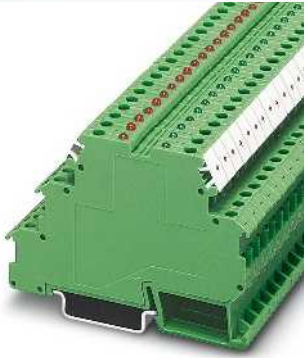

For inductive proximity sensors acc. to NAMUR

ERC

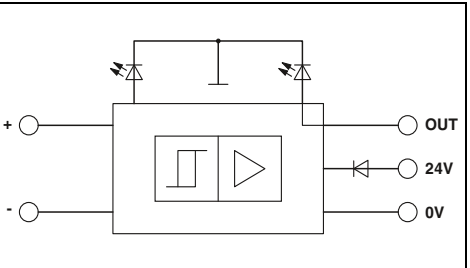

Derating curve for EIK 1-SVN 24 P

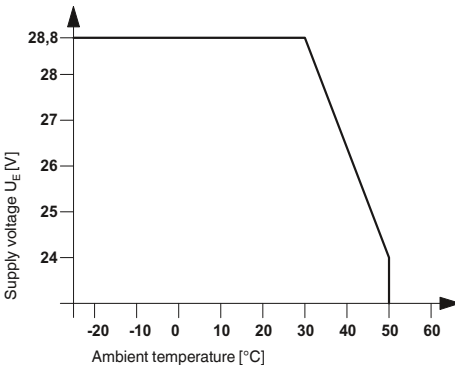

Supply	Input supply nominal voltage U_{VN}
Ripple	Current consumption I_{Imax} Input circuit
Control circuit	Non-load voltage Switching points in accordance with EN 60947-5-6:
Switching hysteresis	Internal resistance
Output protection	Output protection
Signal output	Maximum output current I_{Amax} Residual voltage U_R with I_{Omax} Output voltage U_O
Output protection	Output protection
General data	Ambient temperature (operation) Transmission frequency (INPUT/OUTPUT) Input pulse length Input pause length Standards/regulations Degree of pollution / Overvoltage category
Screw connection solid/stranded/AWG	0.2 - 4 mm ² / 0.2 - 2.5 mm ² / 24 - 12
Dimensions	6.2 mm / 80 mm / 56 mm
EMC note	Class A product, see page 605

Technical data	
Input supply nominal voltage U_{VN}	18.5 V DC ... 28.8 V DC (U_{VN} , see derating curve)
Current consumption I_{Imax}	in acc. with DIN 19240 70 mA (at 50 mA output current) Green LED, Polarity protection diode
Non-load voltage	8.2 V DC \pm 10 % \geq 2.1 mA (In conductive state) \leq 1.2 mA (In blocking state) 6.3 mA ... 10 mA (in the event of a short-circuit) 0 mA ... 0.35 mA (In the event of a wire break) approx. 0.2 mA approx. 1 k Ω visual short-circuit and wire break control with LED (red), 12 V Zener diode
Maximum output current I_{Amax}	50 mA
Residual voltage U_R with I_{Omax}	\leq 1.5 V (U_R) \leq 100 mV (In conductive state) $U_{VN} - U_R$ in blocking state
Output protection	36 V Zener diode as freewheeling diode
Ambient temperature (operation)	-25 °C ... 50 °C
Transmission frequency (INPUT/OUTPUT)	1 kHz
Input pulse length	\geq 0.5 ms
Input pause length	\geq 0.5 ms
Standards/regulations	IEC 60664, EN 61000-6-2, EN 61000-6-4
Degree of pollution / Overvoltage category	2 / III

Application 1

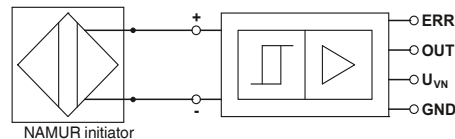

Application 2

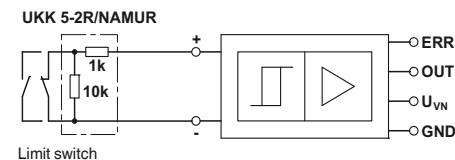

Description
Switching amplifier electronic terminal block , for inductive proximity sensors as per NAMUR, with light indicators for sensor signal and faults
Terminal block , with three through contacts, for mounting on NS 35...
Double-level terminal block , with pre-assembled resistors
Insertion bridge

Ordering data		
Type	Order No.	Pcs./ Pkt.
EIK1-SVN-24P	2940799	10

Accessories		
Type	Order No.	Pcs./ Pkt.
DIKD 1,5	2715979	50
UKK 5-2R/NAMUR	2941662	50
EB...-DIK...		
Ordering data at DEK-REL...		

DEK-TR/INV inverter module

Notes:
Type of housing: Polyamide PA, non-reinforced, color: green.
Marking systems and mounting material See Catalog 3

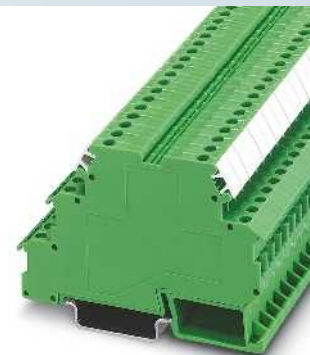

The DEK-TR/INV inverter module inverts the signals of ground-switching NPN transistor outputs into positive switching PNP outputs, as well as signals from PNP into NPN signals. See application example.

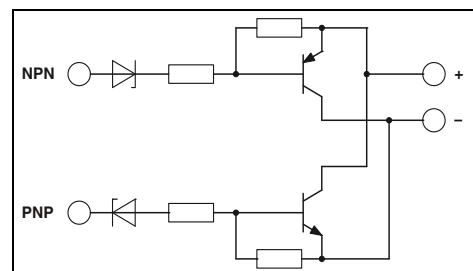

Technical data

Supply voltage	20 V DC ... 30 V DC (U_V)
Continuous current	200 mA
Residual voltage drop	< 1 V
Leakage current	< 1 mA
Maximum transmission frequency	15 kHz
NPN input/PNP output	
Switch-on threshold	< 5 V (at $U_V = 24$ V; < ($U_V - 19$ V))
Switch-off threshold	> 15 V (at $U_V = 24$ V; > ($U_V - 9$ V))
Minimum limit values	-2 V
Maximum limit values	26 V (at $U_V = 24$ V; $U_V + 2$ V)
Control circuit	
Switch-on threshold	> 19 V
Switch-off threshold	< 9 V
Minimum limit values	-2 V
Maximum limit values	26 V (at $U_V = 24$ V; $U_V + 2$ V)
General data	
Ambient temperature (operation)	-20 °C ... 50 °C
Standards/regulations	IEC 60664
	Basic insulation
	2 / II
Degree of pollution / Overvoltage category	
Screw connection solid/stranded/AWG	0.2 - 4 mm ² / 0.2 - 2.5 mm ² / 24 - 12
Dimensions	6.2 mm / 80 mm / 56 mm

Ordering data

Description	Type	Order No.	Pcs./ Pkt.
Inverter module	DEK-TR/INV	2964319	10

Connection examples:

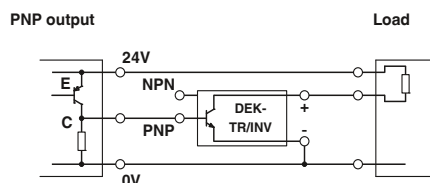
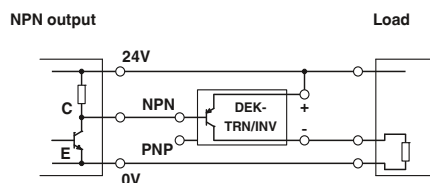

Relay modules

Special relays and solid-state relays

Hybrid relay modules

With its integrated transistor level, the hybrid relay module is able to amplify weak input signals. This serves as the basis for reliable relay operation.

The advantages:

- Low control current (terminal B), type-dependent as of 0.5 mA
- Type-dependent positive or negative control current
- Integrated input and interference suppression circuit
- Safe isolation according to DIN EN 50178 between coil and contact

Notes:
Type of housing: Polycarbonate PC-F, fiber-reinforced, color: green.
Marking systems and mounting material See Catalog 3
For the protection of relay coils and contacts, inductive loads must be dampened with an efficient protection circuit.

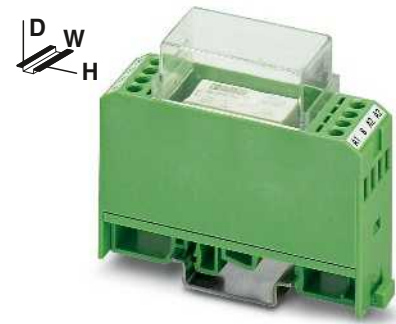

Positive switching hybrid relay

ERC

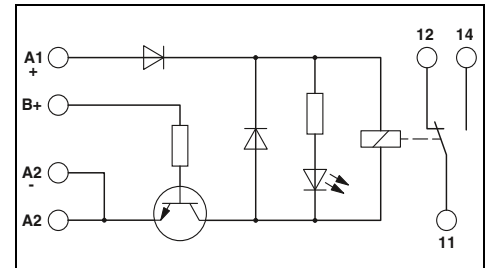

Technical data

Input data	①	②	③
Relay supply voltage $U_N \pm 10\%$	[V DC] 24	24	24
Minimum control voltage	[V DC] 2.7	5	15
Maximum control voltage	[V DC] 5.25	13.2	35
Minimum control current	[mA] 2.6	0.5	0.5
Maximum control current	[mA] 7.7	1	1
Typical input current at U_N	[mA] 21	21	21
Response/release time at U_N	[ms] 9 / 10	9 / 10	9 / 10
Input protection:	Yellow LED, reverse polarity protection, freewheeling diode		
Output data			
Contact type	Single contact, 1-PDT		
Contact material	AgNi		
Max. switching voltage	250 V AC/DC		
Limiting continuous current	5 A		
Maximum switch-on current	8 A		
Maximum interrupting rating, ohmic load	24 V DC	120 W	
	48 V DC	60 W	
	60 V DC	50 W	
	110 V DC	50 W	
	220 V DC	80 W	
	250 V AC	1250 VA	
General data			
Test voltage (winding / contact)	4 kV AC (50 Hz, 1 min.)		
Ambient temperature (operation)	-20 °C ... 50 °C		
Mechanical service life	Approx. 5×10^7 cycles		
Standards/regulations	IEC 60664, EN 50178		
Degree of pollution/surge voltage category	2 / III		
Connection data solid/stranded/AWG	0.2 - 4 mm ² / 0.2 - 2.5 mm ² / 24 - 12		
Dimensions	W / H / D	22.5 mm / 75 mm / 62.5 mm	
EMC note	Class A product, see page 605		
Ordering data			
Type	Order No.	Pcs./ Pkt.	
EMG 22-REL/KSR-G 24/TRN 5	2949787	10	
EMG 22-REL/KSR-G 24/TRN12	2952363	10	
EMG 22-REL/KSR-G 24/TRN35	2952350	10	
Accessories			
EMG-GKS 12	2947035	50	

Description	Nominal control voltage
Relay module with miniature power contact relay with integrated NPN transistor control, for low control currents	① 5 V DC
	② 12 V DC
	③ 24 V DC
Relay module with miniature power contact relay with integrated PNP transistor control, for low control currents	① 5 V DC
	② 12 V DC
	③ 24 V DC

Equipment marker

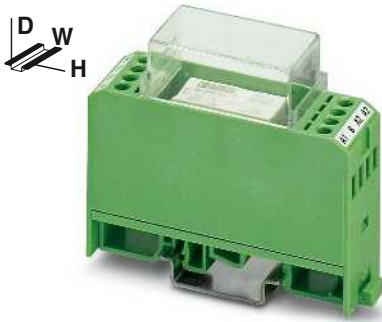

Negative switching hybrid relay

ERC

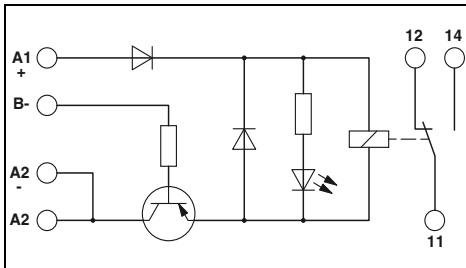

Technical data

①	②	③
24	24	24
-2.4	-6.9	-17.5
-5.25	-13.2	-38.5
1.2	0.6	0.6
1.7	1	1.4
21	21	21
9 / 10	9 / 10	9 / 10

Yellow LED, reverse polarity protection, freewheeling diode

Single contact, 1-PDT

AgNi
250 V AC/DC
5 A
8 A

120 W
60 W
50 W
50 W
80 W
1250 VA

4 kV AC (50 Hz, 1 min.)
-20 °C ... 50 °C
Approx. 5x 10⁷ cycles
IEC 60664 , EN 50178
2 / III

0.2 - 4 mm² / 0.2 - 2.5 mm² / 24 - 12
22.5 mm / 75 mm / 62.5 mm
Class A product, see page 605

Ordering data

Type	Order No.	Pcs./ Pkt.
EMG 22-REL/KSR-G 24/TRP 5	2949790	10
EMG 22-REL/KSR-G 24/TRP12	2952156	10
EMG 22-REL/KSR-G 24/TRP35	2952169	10

Accessories

EMG-GKS 12	2947035	50
------------	---------	----

Relay modules

Relays with force-guided contacts

Fully assembled RIF-1 coupling relay module with force-guided contacts

Fully assembled RIF-1 coupling relay module with force-guided contacts, consisting of:

- Relay base with Push-in connection
- 2-PDT relay with force-guided contacts according to EN 50205
- Relay retaining bracket
- Interference suppression module

The advantages:

- Switching current of up to 2x 6 A
- Single-channel control
- Force-guided contacts according to EN 50205
- Professional bridging of adjacent modules saves wiring time
- Integrated status LED and freewheeling diode

Notes:
Further voltage variants on request



new

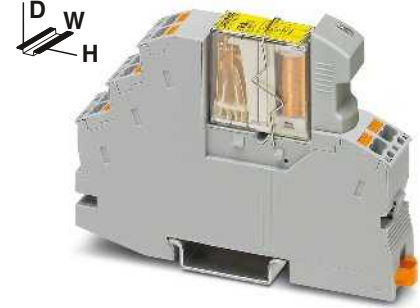

2-PDT relay module with force-guided contacts, max. 2 x 6 A

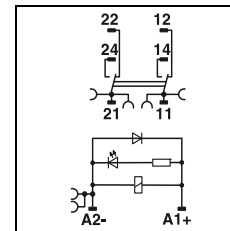

Input data	
Permissible range (with reference to U_N)	
Typical input current at U_N	[mA] 30
Typical response time at U_N	[ms] 10
Typical release time at U_N	[ms] 10
Input circuit DC	Yellow LED, damping diode
Output data	
Contact type	2 PDT, force-guided
Contact material	AgNi
Max. switching voltage	250 V AC/DC
Minimum switching voltage	15 V AC/DC
Limiting continuous current	6 A
Maximum switch-on current	6 A
Minimum switching current	10 mA
General data	
Ambient temperature (operation)	-20 °C ... 50 °C
Nominal operating mode	100% operating factor
Mechanical service life	Approx. 10 ⁷ cycles
Standards/regulations	DIN EN 50178/VDE 0160, EN 50205
Degree of pollution/surge voltage category	2 / III
Mounting position/mounting	any / in rows with zero spacing
Connection data solid/stranded/AWG	0.14 ... 1.5 mm ² / 0.14 ... 1.5 mm ² / 26 - 16
Dimensions	16 mm / 93 mm / 70 mm
EMC note	Class A product, see page 605

Technical data

①	see diagram
①	30
①	10
①	10
①	Yellow LED, damping diode
①	2 PDT, force-guided
①	AgNi
①	250 V AC/DC
①	15 V AC/DC
①	6 A
①	6 A
①	10 mA
①	-20 °C ... 50 °C
①	100% operating factor
①	Approx. 10 ⁷ cycles
①	DIN EN 50178/VDE 0160, EN 50205
①	2 / III
①	any / in rows with zero spacing
①	0.14 ... 1.5 mm ² / 0.14 ... 1.5 mm ² / 26 - 16
①	16 mm / 93 mm / 70 mm
①	Class A product, see page 605

Description	Input voltage U_N
Coupling relay module with power contact relay and force-guided contacts, Push-in connection	① 24 V DC
Force-guided coupling relay with power contacts	① 24 V DC

Ordering data

Type	Order No.	Pcs./Pkt.
RIF-1-RPT-LDP-24DC/2X21/FG	2908215	10

new

RIF-1-RPT-LDP-24DC/2X21/FG



2-PDT relay with force-guided contacts, max. 2 x 6 A



Operating voltage range

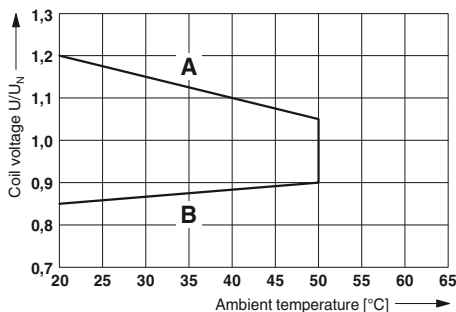

Contact derating

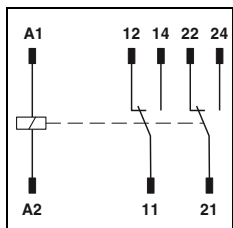
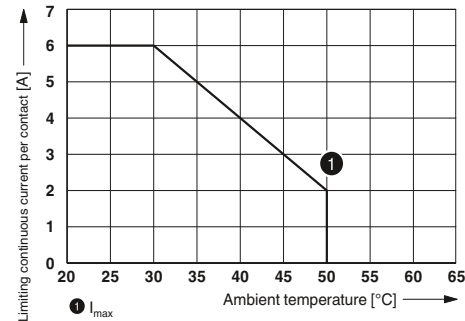

Technical data

① see diagram
29
10
4

2 PDT
AgNi
250 V AC/DC
15 V
6 A
6 A
10 mA

-25 °C ... 70 °C
100% operating factor
Approx. 10⁷ cycles
DIN EN 50178, IEC 60664-1
2 / III

- ... - / - ... - / -
12.6 mm / 29 mm / 25.5 mm

Ordering data

Type	Order No.	Pcs./ Pkt.
REL-SR- 24DC/2X21/FG	2908777	20

REL-SR- 24DC/2X21/FG

Operating voltage range

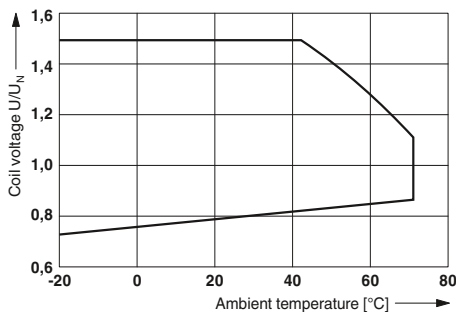

Interrupting rating

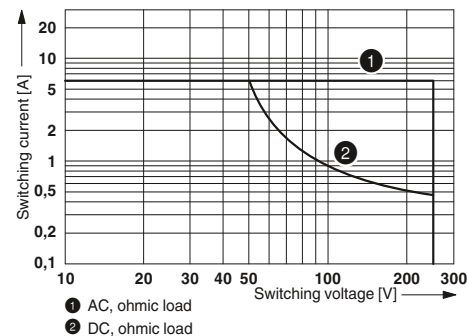

Relay modules

Relay modules for potentially explosive areas (Zone 2)

PLC-INTERFACE for hazardous areas

Relay modules with ATEX, IECEx, and Class 1, Division 2 approval for potentially explosive applications as well as solid-state relays with Class 1, Division 2 approval.

The advantages:

- Slim design
- Functional plug-in bridges
- Integrated input and interference suppression circuit
- RTIII-sealed relays
- Safe isolation according to DIN EN 50178 between coil and contact

Notes:
Type of insulating housing: Polyamide PBT, non-reinforced, color: green.
Marking systems and mounting material See Catalog 3
The PLC-ATP partition plate must be installed for voltages larger than 250 V (L1, L2, L3) between identical terminal blocks in adjacent modules. Potential bridging is then carried out with FBST 8-PLC... or FBST 500....
¹⁾ Ambient temperature (operation): -40°C ... 55°C (ATEX / IECEx)



1-PDT relay module,
6 A, maximum



2-PDT relay module,
2 x 6 A, maximum

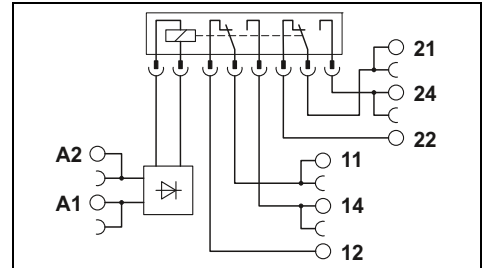
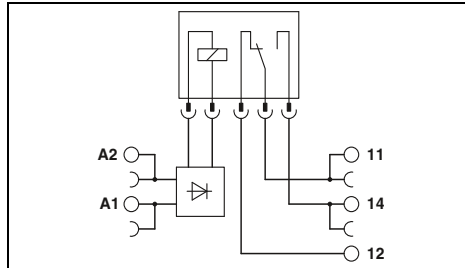

Technical data

Input data	①	②	③	④	
Permissible range (with reference to U _N)	See diagram				
Switching level (with reference to U _N)	1 signal ("H") 0 signal ("L")				
Typical input current at U _N	[mA]	15.3	9	3.5	3.2
Typical response time/switch-on time at U _N	[ms]	5	5	6	7
Typical release time/switch-off time at U _N	[ms]	8	8	15	15
Transmission frequency f _{limit}	[Hz]				
Input circuit DC	Yellow LED, reverse polarity protection, freewheeling diode				
Input circuit AC/DC	Yellow LED, bridge rectifier				
Output data					
Contact material	AgSnO				
Max. switching voltage	250 V AC/DC				
Minimum switching voltage	5 V (at 100 mA)				
Limiting continuous current	6 A				
Maximum switch-on current	10 A (4 s)				
Minimum switching current	10 mA (at 12 V)				
Output protection	-				
Voltage drop at maximum limiting continuous current	-				
General data					
Test voltage input/output	4 kV AC (50 Hz, 1 min.)				
Ambient temperature (operation)	-20 °C ... 60 °C (UL), -40 °C ... 60 °C (ATEX / IECEx)				
Mechanical service life	2 x 10 ⁷ cycles				
Standards/regulations	IEC 60664, EN 50178, EN 60079-0, -7, -15				
Degree of pollution/surge voltage category	3 / III				
Connection data solid/stranded/AWG	0.14 - 2.5 mm ² / 0.14 - 2.5 mm ² / 26 - 14				
Dimensions	W / H / D				
EMC note	6.2 mm / 80 mm / 94 mm				
Conformance/Approvals					
Conformance	CE-compliant				
ATEX	Ex II 3G Ex ec nC IIC T4 Gc (IBExU16ATEXB015 X)				
IECEX	Ex ec nC IIC T4 Gc (IECEX IBE 16.0029X)				
UL, USA	Class I, Zone 2, AEx nA nC IIC T6				
UL, USA/Canada	Class I, Div. 2, Groups A, B, C, D				
UL, Canada	Class I, Zone 2, Ex nA nC IIC Gc T6 X				

Input data	①	②	③	④	
Permissible range (with reference to U _N)	See diagram				
Switching level (with reference to U _N)	1 signal ("H") 0 signal ("L")				
Typical input current at U _N	[mA]	33	18	4.5	4.5
Typical response time/switch-on time at U _N	[ms]	8	8	7	7
Typical release time/switch-off time at U _N	[ms]	10	10	10	10
Transmission frequency f _{limit}	[Hz]				
Input circuit DC	Yellow LED, reverse polarity protection, freewheeling diode				
Input circuit AC/DC	Yellow LED, bridge rectifier				
Output data					
Contact material	AgNi				
Max. switching voltage	250 V AC/DC				
Minimum switching voltage	5 V AC/DC (at 10 mA)				
Limiting continuous current	6 A				
Maximum switch-on current	15 A (300 ms)				
Minimum switching current	10 mA (At 5 V)				
Output protection	-				
Voltage drop at maximum limiting continuous current	-				
General data					
Test voltage input/output	4 kV AC (50 Hz, 1 min.)				
Ambient temperature (operation)	-20 °C ... 60 °C (UL), -40 °C ... 60 °C (ATEX / IECEx)				
Mechanical service life	3 x 10 ⁷ cycles				
Standards/regulations	IEC 60664, EN 50178, EN 60079-0, -7, -15				
Degree of pollution/surge voltage category	2 / III				
Connection data solid/stranded/AWG	0.14 - 2.5 mm ² / 0.14 - 2.5 mm ² / 26 - 14				
Dimensions	W / H / D				
EMC note	14 mm / 80 mm / 94 mm				
Conformance/Approvals					
Conformance	CE-compliant				
ATEX	Ex II 3G Ex ec nC IIC T4 Gc (IBExU16ATEXB015 X)				
IECEX	Ex ec nC IIC T4 Gc (IECEX IBE 16.0029X)				
UL, USA	Class I, Zone 2, AEx nA nC IIC T6				
UL, USA/Canada	Class I, Div. 2, Groups A, B, C, D				
UL, Canada	Class I, Zone 2, Ex nA nC IIC Gc T6 X				

Ordering data

Description	Input voltage U _N
PLC-INTERFACE, with screw connection	
①	12 V DC
②	24 V DC
③	120 V AC / 110 V DC
④	230 V AC / 220 V DC
PLC-INTERFACE, with Push-in connection	
①	12 V DC
③	24 V DC
④	120 V AC / 110 V DC
⑤	230 V AC / 220 V DC

Type	Order No.	Pcs./Pkt.
PLC-RSC-12DC/21/EX	2909522	10
PLC-RSC-24DC/21/EX	2909524	10
PLC-RSC-120UC/21/EX	2909525	10
PLC-RSC-230UC/21/EX ¹⁾	2909526	10
PLC-RPT-12DC/21/EX	2909527	10
PLC-RPT-24DC/21/EX	2909528	10
PLC-RPT-120UC/21/EX	2909529	10
PLC-RPT-230UC/21/EX ¹⁾	2909530	10

Ordering data

Type	Order No.	Pcs./Pkt.
PLC-RSC-12DC/21-21/EX	2909517	10
PLC-RSC-24DC/21-21/EX	2909509	10
PLC-RSC-120UC/21-21/EX	2909511	10
PLC-RSC-230UC/21-21/EX ¹⁾	2909512	10
PLC-RPT-12DC/21-21/EX	2909513	10
PLC-RPT-24DC/21-21/EX	2909514	10
PLC-RPT-120UC/21-21/EX	2909515	10
PLC-RPT-230UC/21-21/EX ¹⁾	2909516	10

Relay modules for potentially explosive areas (Zone 2)

new



1-PDT relay module, max. 10 A



Solid-state relay module, DC output max. 3 A



Solid-state relay module, DC output max. 100 mA

Ex:

Ex:

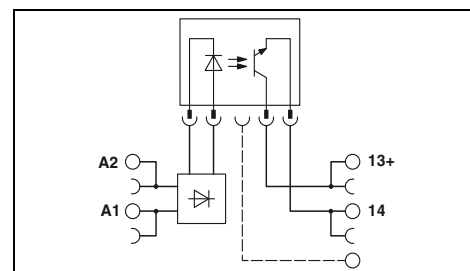
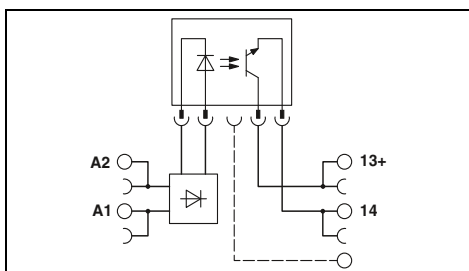
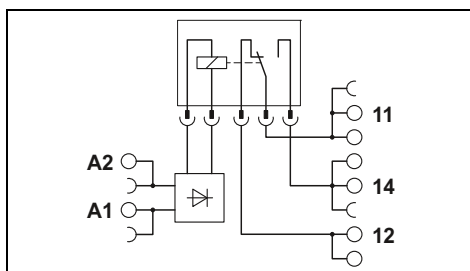

Technical data

Technical data

Technical data

① ② ③ ④
See diagram

②	③
0.8 - 1.2	0.9 - 1.1
≥ 0.8	≥ 0.8
≤ 0.4	≤ 0.3
8.5	3.5
0.02	3.5
0.3	7
300	10

②	③
0.8 - 1.2	0.9 - 1.1
≥ 0.8	≥ 0.9
≤ 0.4	≤ 0.3
8.5	3.5
0.02	3
0.3	4
300	10

Yellow LED, reverse polarity protection, freewheeling diode
Yellow LED, bridge rectifier

Yellow LED, reverse polarity protection, freewheeling diode
Yellow LED, bridge rectifier

Yellow LED, reverse polarity protection, freewheeling diode
Yellow LED, bridge rectifier

AgNi
250 V AC/DC
12 V AC/DC
10 A
30 A (300 ms)
100 mA
-

-
33 V DC
3 V DC
3 A
15 A (10 ms)
-

-
48 V DC
3 V DC
100 mA
-

4 kV AC (50 Hz, 1 min.)
-20 °C ... 60 °C (UL), -40 °C ... 60 °C (ATEX / IECEx)
3 x 10⁷ cycles
IEC 60664, EN 50178, EN 60079-0, -7, -15
2 / III
0.14 - 2.5 mm² / 0.14 - 2.5 mm² / 26 - 14
14 mm / 80 mm / 94 mm

2.5 kV (50 Hz, 1 min.)
-20 °C ... 60 °C
-

2.5 kV (50 Hz, 1 min.)
-20 °C ... 60 °C
-

CE-compliant
Ex II 3G Ex ec nC IIC T4 Gc (IBExU16ATEXB015 X)
Ex ec nC IIC T4 Gc (IECEx IBE 16.0029 X)
Class I, Zone 2, AEx nA nC IIC T6
Class I, Div. 2, Groups A, B, C, D
Class I, Zone 2, Ex nA nC IIC Gc T6 X

CE-compliant
-

CE-compliant
-

Ordering data

Ordering data

Ordering data

Type	Order No.	Pcs./Pkt.
PLC-RSC-12DC/21HC/EX	2909518	10
PLC-RSC-24DC/21HC/EX	2909519	10
PLC-RSC-120UC/21HC/EX	2909520	10
PLC-RSC-230UC/21HC/EX ¹⁾	2909521	10
PLC-RPT-12DC/21HC/EX	2909531	10
PLC-RPT-24DC/21HC/EX	2909532	10
PLC-RPT-120UC/21HC/EX	2909533	10
PLC-RPT-230UC/21HC/EX ¹⁾	2909534	10

Type	Order No.	Pcs./Pkt.
PLC-OSC- 24DC/ 24DC/ 2/C1D2	5603260	10
PLC-OSC-120UC/ 24DC/ 2/C1D2	5603262	10

Type	Order No.	Pcs./Pkt.
PLC-OSC- 24DC/ 48DC/100/C1D2	5603261	10
PLC-OSC-120UC/ 48DC/100/C1D2	5603263	10



System cabling for controllers

Wiring I/O modules with individual wires is an extremely time-consuming process. Wiring errors and tedious troubleshooting cannot be ruled out.

VARIOFACE system components reduce assembly costs by using plug-in components to carry out wiring quickly, clearly, and without errors.

In the case of **controller-specific system cabling**, front adapters, system cables, and modules are specially matched to each other. Individual solutions exist for the following controllers:

- **ABB**
- **Allen Bradley**
- **Emerson**
- **Honeywell**
- **GE Fanuc**
- **Phoenix Contact**
- **Mitsubishi Electric**
- **OMRON**
- **Schneider Electric**
- **Siemens**
- **Yokogawa**

If automation components with high-pos. connectors such as D-SUB are in the control cabinet, **universal modules** and cables are suitable for signal connection. The 1:1 connection is characteristic for these universal all-purpose modules. The modules allow orderly connection of field signals to screw, spring-cage or Push-in technology.

Universal cables connect the control and signal level quickly and without errors.

A wide variety of **potential distributors** are available for splitting the control and operating voltage. The different potential levels and the connection terminal blocks support flexible use.

Individual application requirements can be implemented with customer-specific products (see page 468).

Product range overview

Introduction	462
Product overview	464
<hr/>	
Customer-specific products	468
<hr/>	
Controller-specific system cabling	
For ABB S800 I/O	470
For Allen Bradley, ControlLogix, SLC 500, and PlantScape	472
For Emerson DeltaV	480
For GE Fanuc RX3i and Series 90-30	484
For Honeywell C300 Series CI/O and PlantScape	486
For Mitsubishi A1S and Q, Melsec L, Honeywell ML 200	488
For Omron CJ1, CS1, and C200H	490
For Phoenix Contact Axioline and Inline	491
For Schneider Electric Modicon	493
For Siemens SIMATIC® S7-300	496
For Siemens SIMATIC® S7-1500	510
For Siemens SIMATIC® S7-400	514
For Yokogawa CENTUM VP, ProSafe-RS	516
Termination Carriers for Yokogawa CENTUM VP and ProSafe-RS	524
Passive modules	526
Active modules	536
V8 adapters for PLC-INTERFACE	544
System and splitting cables	551
VIP I/O-Marshalling universal platform	552
<hr/>	
Retrofit and modernization components	558
<hr/>	
Universal modules	
With IDC/FLK connectors	566
With D-SUB connectors	570
With high-density D-SUB connectors	576
With RJ45 connectors	577
With ELCO connectors	578
<hr/>	
Universal cables	
With IDC/FLK connectors	582
With D-SUB connectors	592
<hr/>	
Potential distributors	598

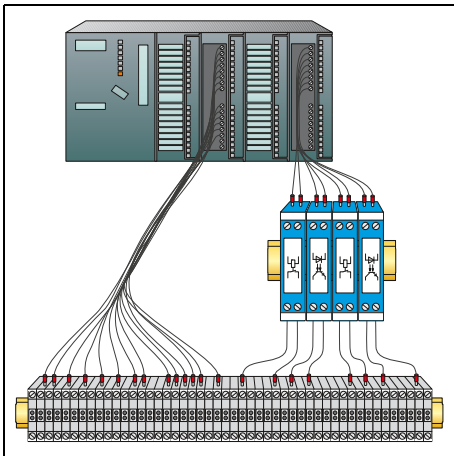

Wiring with single wires

- Time-consuming
- Confusing wiring
- Risk of mixing wires
- Time-consuming troubleshooting

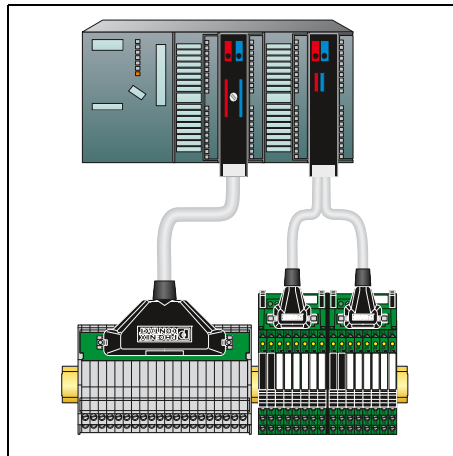

Wiring with the controller-specific system cabling:

- Fast, fault-free wiring
- Plug and Play solution
- Orderly structure
- Considerable time savings



The matching components are selected with the help of the “system cabling for controllers” online configurator:

- Front adapter
- System cables
- Module

For the online configurator, use the web code:

i Your web code: **#0007**

Simply enter “#0007” into the search field on our website.



Front adapter

- Tailored to controller-specific I/O modules
- Plug-in components
- Connection via system cables

8 and 32-channel modules

- Passive modules
- Relay modules
- Controller-specific layout
- Screw or Push-in connection technology

PLC-V8 adapter

- Connection of 8 channels via the "PLC series"
- Feasible functions: relay, solid-state relay or feed-through
- Individual function selection per channel
- Screw or Push-in connection technology

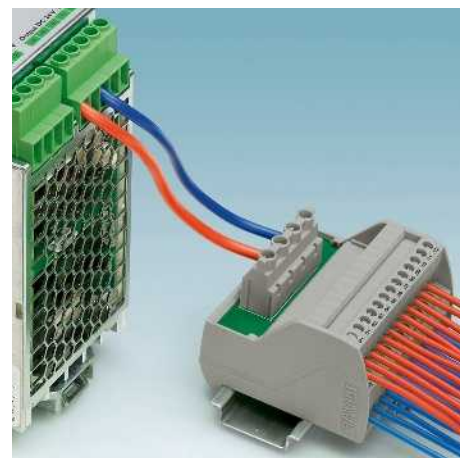
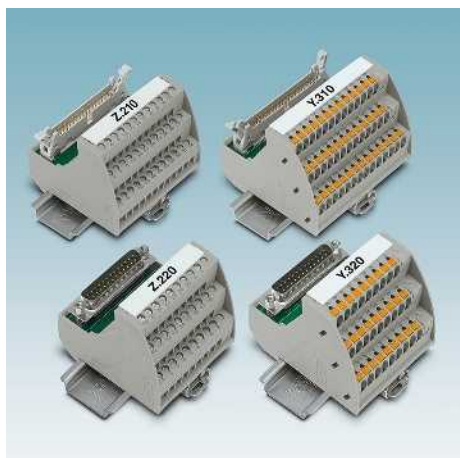

Universal modules

- Connector: IDC/FLK, D-SUB, ELCO or DIN
- 1:1 connection
- Screw or Push-in connection technology
- Optional status indicator

Universal cables

- With IDC/FLK connector
- With D-SUB connector
- Optionally with open end











Potential distributors

- Up to 30 A/250 V
- Two, three or six potential levels
- Screw or Push-in connection technology

System cabling for controllers

Product overview

Controller-specific system cabling

System component		Controller									
		ABB	Allen Bradley		Emerson	GE Fanuc		Honeywell		Mitsubishi	
		S800 I/O	Control Logix	SLC 500	DeltaV	RX3i	90-30	C300 Series CI/O ML 200	PlantScape	MELSEC A, A1S, Q, L	
Version		Page	Page	Page	Page	Page	Page	Page	Page	Page	
Front adapter		not required	472	476	not required	484	485	486	472	not required	
System cable	 Standard	592	550	550	588	550	550	592	550		
	 Controller-specific	471		478	480			489		488	
Termination boards	 Passive Standard	526	526	526	526	526	526	487	526	526	
	 Passive Controller-specific	470	474	477	481						
 Active Standard	536	536	536	536	536	536	536	536	536		
 V8 adapter	544	544	544	544	544	544	544	544	544		
	 Relay/optocoupler	368	368	368	368	368	368	368	368	368	
 MINI Analog Pro system adapter											
	 MINI Analog Pro										



	OMRON CJ1	Phoenix Contact	Schneider		Siemens				Yokogawa	
	CS1, CQM1, C200H	Axioline Inline	TSX Quantum™	M340	S7 1500	S7 300	S7 400	Implementation S5 to S7	CENTUM VP	ProSafe RS
	Page	Page	Page	Page	Page	Page	Page	Page	Page	Page
	not required	492	493	494	510	500	514	560	not required	not required
		550	550	550	550	550	550			
	490			495		505			516	516
	526	526	526	526	526	526	526			
			474		510	508	508		520	522
	536	536	536	536	536	536	536			
	544	544	544	544	544	544	544		544	
	368	368	368	368	368	368	368		368	
						97			97	
						68			68	

System cabling for controllers

Product overview

Controller-specific system cabling

VIP I/O-Marshalling universal platform

System component		Version	Page
Base module			552
Plug-in module		Feed-through	554
		Analog	555
		Digital	555
		Relay	556
Cables			596

Universal modules and cables

	Passive modules (connection technology)			
	IDC/FLK strip	D-SUB strip	ELCO strip	Potential distributors
Device series				
	Page	Page	Page	Page
VIP Line	566	570 576		598
Standard Line			580	
Slim Line		574		
Feed-through modules		575		
Cables	582	592		

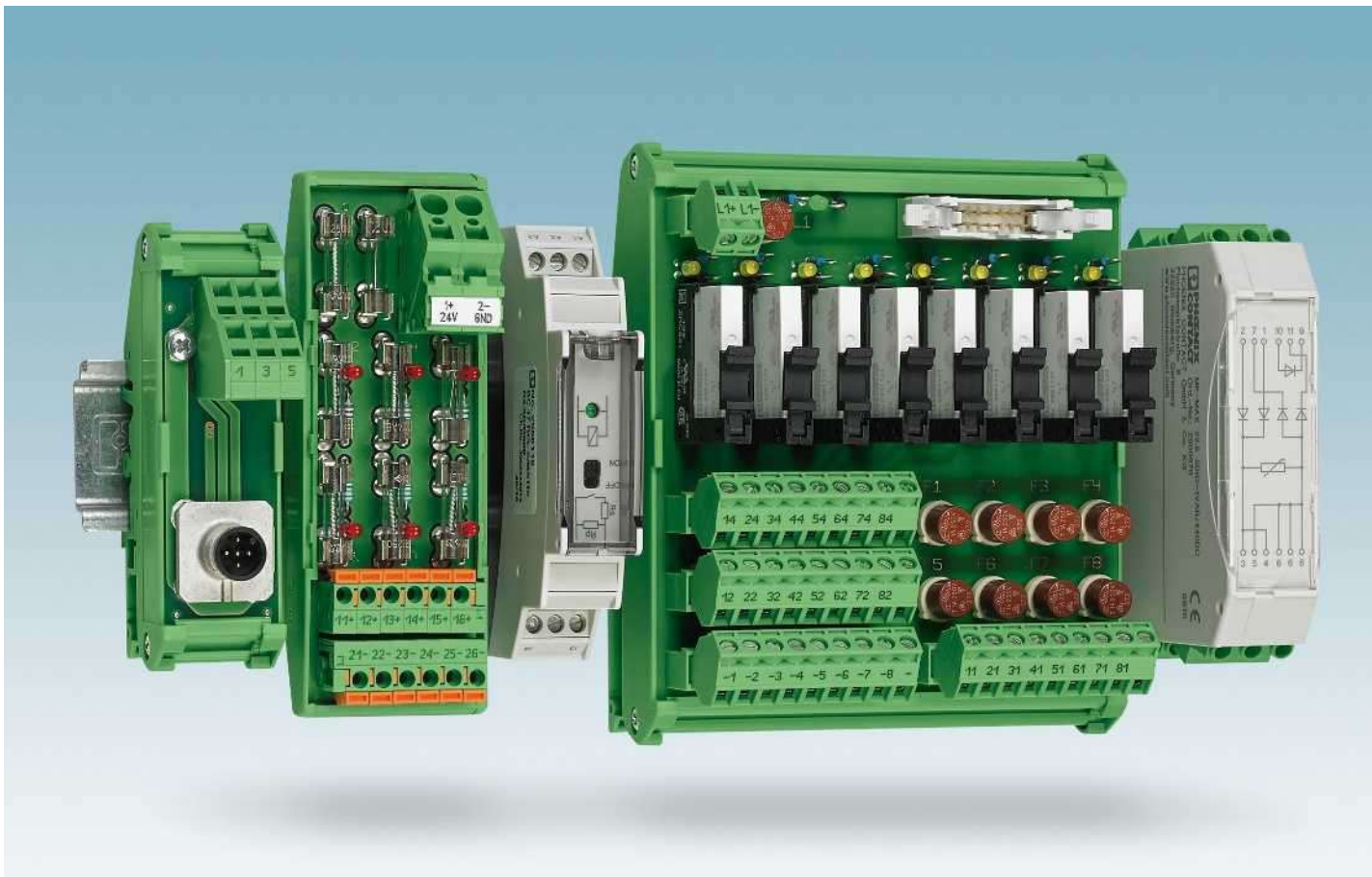

From the enquiry to the product

We develop your product from the idea to series production.

Concept phase

- Realization test according to your specifications
- Personal consultation
- Tendering including draft drawing

Realization phase

- Development according to product creation process
- Circuit diagram and PCB layout
- Component selection
- Creation of functional samples
- Creation of prototypes
- Tests in every phase of development
- EC conformance
- Preparation and implementation of approval procedures
- Environmental tests according to standards
- Documentation

Series phase

- Production according to IPC-A-610 Class 2
- 100% end test with automated test systems
- Lifecycle management

Directives and standards

- Low-voltage directive
- EMC directive
- IEC 60664-1
Insulation coordination for electrical equipment within low-voltage systems
- EN 50178
Electronic equipment for use in power installations
- EN 61000-6
Electromagnetic compatibility
- IPC A-600
Acceptance criteria for PCBs
- IPC-A-610
Acceptance criteria for electronic modules

Components used

We use connection technology and housings from the comprehensive Phoenix Contact portfolio.

Here you find all common market technologies:

- Screw and spring-cage connection
- Push-in spring connection
- Knife disconnection
- Modular component housing
- Building installation housings
- Profile module carriers

Furthermore, we use components, connectors, cables as well as PCBs from qualified and certified suppliers.

Product range

We create versions from catalog production for you or new products according to your specifications from the following portfolio:

- Function modules such as diode gates
- Relay and optocoupler modules
- 1:1 installation modules (connector on terminal block)
- Potential distributors
- System cables with high-pos. connectors
- System adapters for controllers and control systems
- Transfer modules for use between controller and field level
- Output modules with electrical isolation
- Module carrier for system cabling of signal conditioners or safe coupling relays

Your direct line to us

Do you have a specific question? Talk to us about it.



Simplification of installation

- Objectives
 - Reduce assembly costs
 - Minimize installation time
 - Optimize space in the control cabinet
- Implementation
 - Analysis of the application
 - Draft of concept
- Result
 - Tailor-made solution from system components (standard and customer-specific)
 - Fault-free wiring

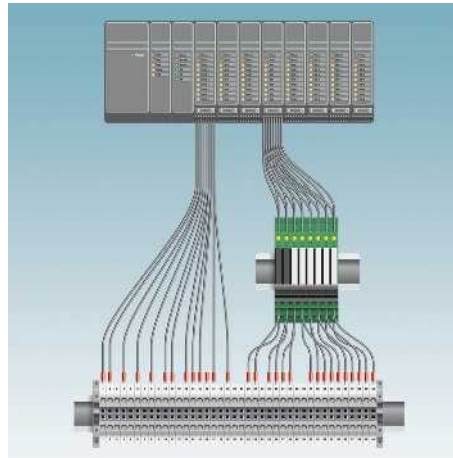

Retrofitting systems

- Task
 - Extension
 - Retrofitting
- Objectives
 - System availability
 - Fulfillment of statutory specifications
- Solution
 - Use adaptation solutions and high-pos. system cables
- Result
 - Minimum downtimes



Pre-assembled system cables

- With high-position connectors
 - D-SUB strips
 - IDC/FLK pin strips (2.54 mm)
- Pre-assembled at one or both ends
- Cables
 - Shielded, unshielded, halogen-free
 - 0.14 mm²/26 AWG and 0.25 mm²/24 AWG
- Quality
 - Continuity and dielectric test
- Other versions available on request.



Installation modules

- 1:1 marshalling terminal to high-pos. connector (D-SUB, HE10, ELCO...)
- Passive transfer modules with system connection
- Potential distributors
- Fuse modules
- Diode modules
- Other modules on request



Relay and optocoupler modules

- With electromechanical relays
- With solid-state relays
- Multi-channel
- With system connection
- N/O contact or PDT contact
- LED status display
- Freewheeling diode
- Reverse polarity protection
- Redundant power supply



Termination Carrier module carrier

- The compact Termination Carrier connects
 - Signal conditioners
 - Signal conditioners for Ex i circuits
 - Signal conditioners for SIL applications
 - Safe coupling relays
- easily with the automation system via system cables.
- The advantages are clear:
 - Quick startup
 - Fault minimization

Controller-specific system cabling

ABB S800 I/O

Termination boards with knife disconnection

The ABB S800 I/O system can be used to install the process wiring via D-SUB connectors. The ABB TU 812 Compact MTU is available for this purpose.

The FLKM-D25SUB/B/KDS3-MT/... modules are connected to the I/O modules via assembled D-SUB cables (see page 592).

In addition to screw connection with knife disconnection for every channel and ABB S800-specific marking, the modules have the following features:

- Eight negative terminals with knife disconnection (TU810)
- Eight positive terminals with knife disconnection (TU810/P)
- For each channel, there is a positive and negative terminal with knife disconnection (TU830)

Passive termination boards can also be used for signal transmission (e.g., VIP-3/SC/D25SUB/F, 2315188), see page 571.

Web code for the online configurator

i Your web code: #0007

Connectable I/O modules

Card type	FLKM-D25SUB...				
	...TU810	...TU810/P	...TU830		
Digital input	DI 814	DI 810	DI 810		
		DI 811	DI 811		
		DI 814	DI 814		
		DI 818	DI 818		
		DI 830	DI 830		
		DI 831	DI 831		
		DI 840	DI 840		
		DI 885	DI 885		
		Digital output	DO 814	DO 810	DO 810
				DO 814	DO 814
DO 818	DO 818				
DO 840	DO 840				
Analog input	AI 845	AI 810	AI 810		
		AI 815	AI 815		
		AI 820	AI 820		
		AI 830	AI 830		
		AI 835	AI 835		
		AI 845	AI 845		
Analog output	AO 845	AO 810	AO 810		
		AO 815	AO 815		
		AO 820	AO 820		
		AO 845	AO 845		
Miscellaneous	DP 820	DP 820	DP 820		



Explanation:

- IDC/FLK strip
- Connection to I/O card
- Screw terminal blocks for separate supply

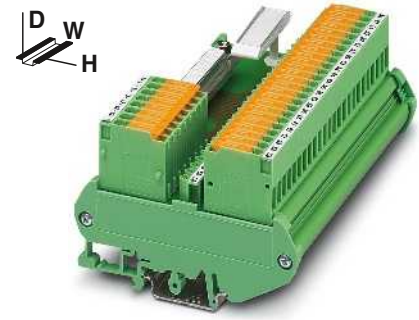

Termination board with knife disconnect terminal blocks

Technical data

Maximum permissible operating voltage	< 50 V AC / 60 V DC
Maximum permissible current (per branch)	2 A
Maximum total current (voltage supply)	4 A (8 A L1-/L2-)
Ambient temperature (operation)	-20 °C ... 50 °C
Mounting position	any
Standards/regulations	DIN EN 50178 , IEC 60664
Connection method	Screw connection with disconnect knife
Field level	D-SUB socket strip
Controller level	0.2 ... 4 mm ² / 0.2 ... 2.5 mm ² / 24 - 12
Connection data solid/stranded/AWG	90 mm / 61 mm
Dimensions	H / D

Ordering data

Type	Order No.	Pcs./Pkt.
FLKM-D25 SUB/B/KDS3-MT/TU810	2304513	1
FLKM-D25 SUB/B/KDS3-MT/TU810/P	2304539	1
FLKM-D25 SUB/B/KDS3-MT/TU830	2304526	1

Description	No. of pos.	Module width W
VARIOFACE module , with knife disconnect terminal blocks in ABB-specific marking:		
- with 8 negative terminal blocks	25	126.5 mm
- with 8 positive terminal blocks	25	126.5 mm
- each with 16 positive and negative terminal blocks	25	247.5 mm

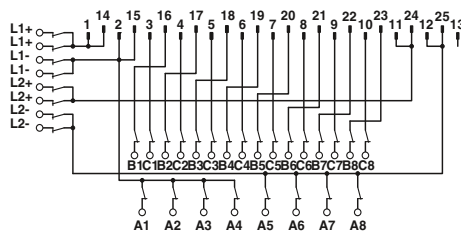

FLKM-D25 SUB/B/KDS3-MT/TU810 connection scheme

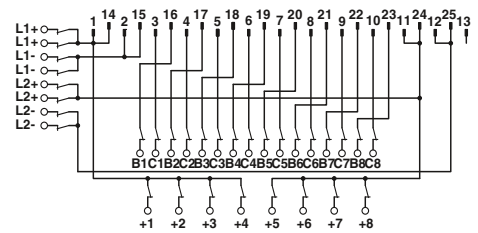

FLKM-D25 SUB/B/KDS3-MT/TU810/P connection scheme

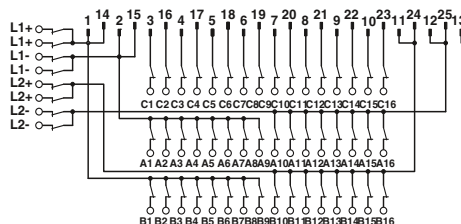

FLKM-D25 SUB/B/KDS3-MT/TU830 connection scheme

ABB S800 I/O System cable

The ABB S800 I/O system can be used to install the process wiring via D-SUB connectors. The ABB TU 812 Compact MTU is available for this purpose.

The CABLE-D25SUB/B/2X14/.../TU812 system cables convert digital signals from a D-SUB socket strip to two IDC/FLK socket strips. Therefore, all 8-channel termination boards of the system cabling are connected to S800 I/O modules. Two termination boards are used per module.



System cable



Technical data

Maximum permissible operating voltage	25 V AC / 60 V DC
Maximum permissible operating voltage UL / CSA	125 V / -
Maximum permissible current carrying capacity per path	1 A
Ambient temperature (operation)	-20 °C ... 50 °C
Assembly	Insulation displacement, IEC 60352-4/DIN EN 60352-4
Conductor cross section	AWG 26 / 0.14 mm ²
Conductor structure: stranded wires / material	7 / Cu tin-plated
Outside diameter	6.3 mm
	25-pos.

Ordering data

Description	No. of pos.	Cable length	Type	Order No.	Pcs./ Pkt.
VARIOFACE system cable , for S800 I/O, with a 25-pos. D-SUB socket strip and two 14-pos. IDC/FLK socket strips, in standard lengths	25	1 m	CABLE-D25SUB/B/2X14/100/TU812	2304649	1
	25	2 m	CABLE-D25SUB/B/2X14/200/TU812	2304652	1
	25	3 m	CABLE-D25SUB/B/2X14/300/TU812	2304665	1
	25	5 m	CABLE-D25SUB/B/2X14/500/TU812	2304678	1
VARIOFACE system cable , for S800 I/O, with a 25-pos. D-SUB socket strip and two 14-pos. IDC/FLK socket strips, in variable lengths	25		CABLE-D25SUB/B/2X14/TU812/...	2304681	1

Color code and pin assignment CABLE-D25SUB/B/2X14...TU812

D-SUB connector 25-pos.	FLK 14 1st connector	FLK 14 2nd connector	Wire color
1	9		Gray
2	10		White
3	1		Black
4	3		Red
5	5		Yellow
6	7		Blue
7		1	Black
8		3	Red
9		5	Yellow
10		7	Blue
11		9	Orange
12		10	White
13	NC	NC	-
14	11		White-black
15	12		White-brown
16	2		Brown
17	4		Orange
18	6		Green
19	8		Violet
20		2	Brown
21		4	Orange
22		6	Green
23		8	Violet
24		11	White-black
25		12	White-brown

Ordering example for system cable:

- Cable for ABB S800, 12.75 m long

Quantity	Order No.	Length [m] ¹⁾
1	2304681	12.75

¹⁾ min. 0.20 m

System cabling for controllers

Controller-specific system cabling

Allen Bradley ControlLogix, Honeywell PlantScape Front adapter

I/O modules with 32 channels or of this type

The front adapters are pushed into the tall 1756-TBE covers (not supplied as standard, original accessories must be ordered directly from manufacturer) of the controller. A 50-pos. system cable can connect a maximum of 32 channels to the field level.

Tailor-made VARIOFACE termination boards round off this system concept.

Web code for the online configurator

i Your web code: **#0007**

Notes:
Front adapters can also be used without cover.
Controller-specific modules from page 474
Standard modules from page 526
For system cables, see page 550



**32-channel front adapter
with 50-pos. FLK strip**



Technical data

Maximum permissible operating voltage
Maximum permissible operating voltage UL / CSA

< 50 V AC / 60 V DC
125 V / -

Maximum permissible current

1 A (per path)
8 A (per connection, supply via separate power supply)

Ambient temperature (operation)
Ambient temperature (storage/transport)
Connection data solid/stranded/AWG
Standards/regulations

-20 °C ... 50 °C
-20 °C ... 70 °C
0.14 ... 1.5 mm² / 0.14 ... 1.5 mm² / 28 - 16
DIN EN 50178 / IEC 60664

Ordering data

Description	No. of pos.
VARIOFACE front adapters, for ControlLogix:	
- A maximum of 1 x 32 channels can be connected	50
- IB 32 input board	50

Type	Order No.	Pcs./ Pkt.
FLKM 50-PA-AB/1756/EXTC	2302735	1
FLKM 50-PA-AB/1756/IN/EXTC	2302748	1

Front adapters for I/O modules of the Allen Bradley ControlLogix and Honeywell PlantScape automation devices

Card type	FLKM 50-PA-AB/1756/EXTC
Digital input	1756-IA 16 I* or TC-TDK 161* 1756-IB 16 D* or TC-TDX 161* 1756-IB 16 I* or TC-TDJ 161* 1756-IH 16 I*
Digital output	1756-OB 32 or TC-ODD 321
Analog input	1756-IF 8* 1756-IF 16 I* or TC-IAH 161* 1756-IF 8H* or TC-HAI 081*
Counter	1756-HSC*
Servo	1756-M02 AE*
Card type	FLKM 50-PA-AB/1756/IN/EXTC
Digital input	1756-IB 32 or TC-IDD 321

* Only in conjunction with
VIP-2/SC/FLK50/AB-1756, Order No.: 2322317
VIP-2/PT/FLK50/AB-1756, Order No.: 2904286
There must be no voltage supply at the front adapter. Risk of short circuit!

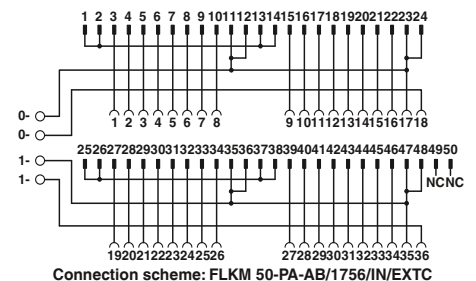
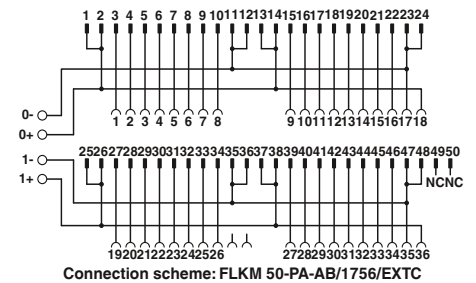

Explanation:

- IDC/FLK strip
- Connection to I/O card
- Screw terminal blocks for separate supply

Allen Bradley ControlLogix, Honeywell PlantScope Front adapter

I/O modules with 16 channels or of this type

The front adapters are pushed into the tall 1756-TBE covers (not supplied as standard, original accessories must be ordered directly from manufacturer) of the controller. Two 14-pos. system cables are used to connect up to 2 x 8 channels to the field level.

Tailor-made VARIOFACE termination boards round off this system concept.

Web code for the online configurator

 Your web code: **#0007**

Notes:
Front adapters can also be used without cover.
Controller-specific modules from page 474
Standard modules from page 526
For system cables, see page 550
1) No UL approval



16-channel front adapter
with two 14-pos. FLK strips



Technical data

Maximum permissible operating voltage
Maximum permissible operating voltage UL / CSA

< 50 V AC / 60 V DC
125 V / -

Maximum permissible current

1 A (per path)
8 A (per connection, supply via separate power supply)

Ambient temperature (operation)
Ambient temperature (storage/transport)
Connection data solid/stranded/AWG
Standards/regulations

-20 °C ... 50 °C
-20 °C ... 70 °C
0.14 ... 1.5 mm² / 0.14 ... 1.5 mm² / 28 - 16
DIN EN 50178 / IEC 60664

Ordering data

Description	No. of pos.
VARIOFACE front adapters, for ControlLogix:	
- Up to 2 x 8 channels can be connected	14
- IA 16, IB 16, IC 16, IN 16 input card	14
- IF6 I input card (only suitable for measuring current; no power terminals on adapter)	14

Type	Order No.	Pcs./Pkt.
FLKM 14-PA-AB/1756/EXTC	2302861	1
FLKM 14-PA-AB/1756/IN/EXTC	2302874	1
FLKM 14-PA-AB/1756/IF6/EXTC ¹⁾	2901037	1

Front adapters for I/O modules of the Allen Bradley ControlLogix and Honeywell PlantScope automation devices

Card type	FLKM 14-PA-AB/1756/EXTC
Digital input	1756-IA 8 D** or TC-IDX 081**
Digital output	1756-OB 16 E
Analog input	1756-IF 6 CIS** 1756-IF 6 I** or TC-IAH 061** 1756-IR 6 I** or TC-IXR 061** 1756-IT 6 I** or TC-IXL 061**
Analog output	1756-OF 4 I** 1756-OF 6 CI** or TC-OAH 061** 1756-OF 6 VI** or TC-OAV 061** 1756-OF 8** or TC-OAV 081** 1756-OF 8 H**
Switch	1756-PLS**

Card type	FLKM 14-PA-AB/1756/IN/EXTC
Digital input	1756-IN 16** 1756-IA 16 or TC-IDA 161** 1756-IB 16 1756-IC 16**

Card type	FLKM 14-PA-AB/1756/IF6/EXTC
Analog input	IF6I**

** Only in conjunction with
VIP-2/SC/2FLK14/AB-1756, Order No.: [2322333](#)
VIP-2/PT/2FLK14/AB-1756, Order No.: [2904288](#)
There must be no voltage supply at the front adapter. Risk of short circuit!

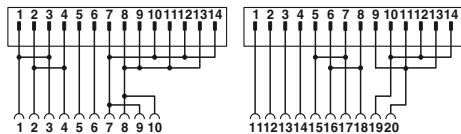

Connection scheme: FLKM 14-PA-AB/1756/IF6/EXTC

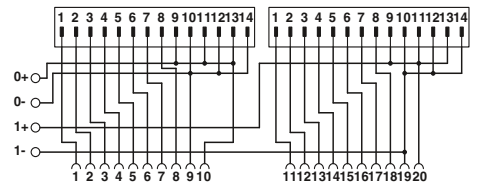

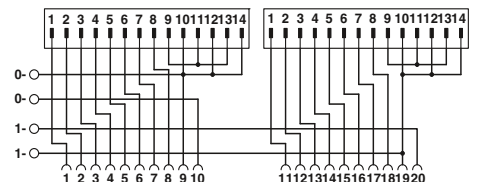

Connection scheme: FLKM 14-PA-AB/1756/EXTC



Connection scheme: FLKM 14-PA-AB/1756/IN/EXTC

Explanation:

-  IDC/FLK strip
-  Connection to I/O card
-  Screw terminal blocks for separate supply

System cabling for controllers

Controller-specific system cabling

VIP termination boards for Modicon TSX Quantum™ and Allen Bradley ControlLogix

These VIP - VARIOFACE Professional modules are used in combination with 50-pos. system cables and the relevant front adapters.

Features:

- Specific marking
- Specifically for Modicon TSX Quantum™ or ControlLogix

Notes:
For marking systems (e.g., "ZB 22:UNBEDRUCKT"; Order No. 0811862) and mounting material, see Catalog 3.

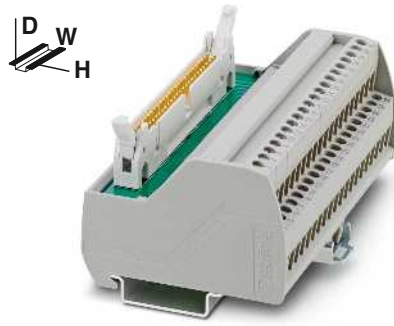

Passive termination boards for input/output, with specific marking and screw connection

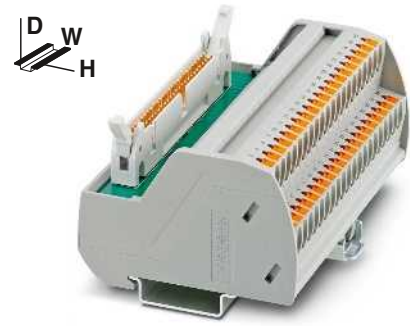

Passive termination boards for input/output, with specific marking and Push-in connection



Technical data

Maximum permissible operating voltage
Maximum permissible operating voltage UL / CSA

60 V AC/DC
125 V / -

Maximum permissible current (per branch)
Ambient temperature (operation)
Mounting position

1 A
-20 °C ... 50 °C
any
IEC 60664 , DIN EN 50178

Standards/regulations
Connection method

Field level
Controller level

Connection data solid/stranded/AWG
Dimensions

IDC/FLK pin strip
0.2 ... 4 mm² / 0.2 ... 2.5 mm² / 24 - 12
65.5 mm / 56 mm

Ordering data

Description	No. of pos.	Module width W
VARIOFACE termination board , with Modicon® TSX Quantum™-specific marking from 1 to 40		
- with screw connection	50	106.1 mm
- with Push-in connection	50	107.9 mm
VARIOFACE termination board , with ControlLogix-specific marking from 1 to 36		
- with screw connection	50	95.9 mm
- with Push-in connection	50	97.7 mm

Type	Order No.	Pcs./ Pkt.
VIP-2/SC/FLK50/MODI-TSX/Q	2322304	1
VIP-2/SC/FLK50/AB-1756	2322317	1

Technical data

60 V AC/DC
125 V / 125 V

1 A
-20 °C ... 50 °C
any

IEC 60664 , DIN EN 50178

Push-in connection
IDC/FLK pin strip
0.14 ... 2.5 mm² / 0.14 ... 2.5 mm² / 26 - 14
72.1 mm / 56 mm

Ordering data

Type	Order No.	Pcs./ Pkt.
VIP-2/PT/FLK50/MODI-TSX/Q	2904285	1
VIP-2/PT/FLK50/AB-1756	2904286	1

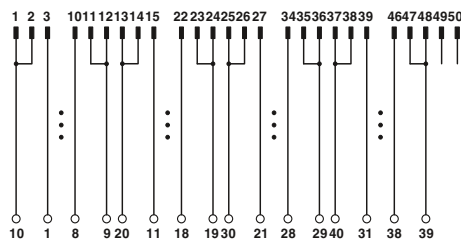

Connection scheme VIP-2/.../FLK50/MODI-TSX/Q

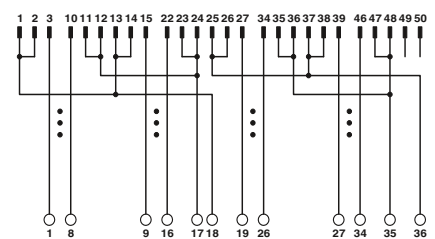

Connection scheme VIP-2/.../FLK50/AB-1756

VIP termination boards for Allen Bradley ControlLogix

These VIP - VARIOFACE Professional modules are used in combination with two 14-pos. system cables and the relevant front adapters for Allen Bradley.

Features:

- Numerical marking (1-20)
- Specifically for ControlLogix

Notes:

For marking systems (e.g., "ZB 22:UNBEDRUCKT"; Order No. 0811862) and mounting material, see Catalog 3.

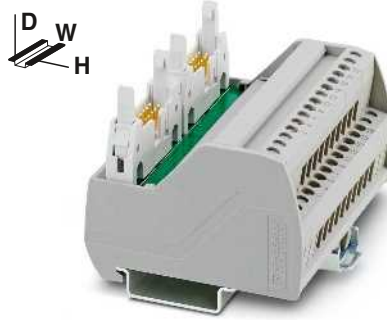

Passive termination boards for Allen Bradley ControlLogix with screw connection

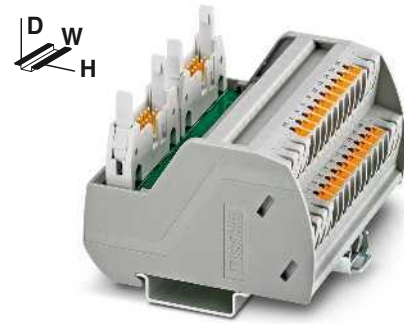

Passive termination boards for Allen Bradley ControlLogix with Push-in connection



Technical data

Maximum permissible operating voltage	60 V AC/DC
Maximum permissible operating voltage UL / CSA	125 V / -
Maximum permissible current (per branch)	1 A
Ambient temperature (operation)	-20 °C ... 50 °C
Mounting position	any
Standards/regulations	IEC 60664 , DIN EN 50178
Connection method	Field level Screw connection
Connection data solid/stranded/AWG	Controller level IDC/FLK pin strip
Dimensions	0.2 ... 4 mm ² / 0.2 ... 2.5 mm ² / 24 - 12 65.5 mm / 56 mm

Technical data

Maximum permissible operating voltage	60 V AC/DC
Maximum permissible operating voltage UL / CSA	125 V / 125 V
Maximum permissible current (per branch)	1 A
Ambient temperature (operation)	-20 °C ... 50 °C
Mounting position	any
Standards/regulations	IEC 60664 , DIN EN 50178
Connection method	Field level Push-in connection
Connection data solid/stranded/AWG	Controller level IDC/FLK pin strip
Dimensions	0.14 ... 2.5 mm ² / 0.14 ... 2.5 mm ² / 26 - 14 72.1 mm / 56 mm

Ordering data

Description	No. of pos.	Module width W
VARIOFACE termination board, with ControlLogix-specific marking from 1 to 20		
- with screw connection	14	80.6 mm
- with Push-in connection	14	82.5 mm

Type	Order No.	Pcs./ Pkt.
VIP-2/SC/2FLK14/AB-1756	2322333	1

Ordering data

Type	Order No.	Pcs./ Pkt.
VIP-2/PT/2FLK14/AB-1756	2904288	1

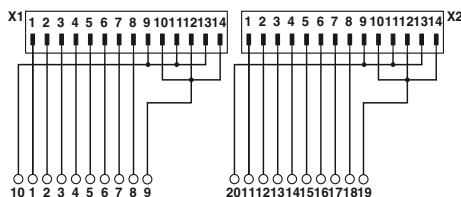

Connection scheme VIP-2.../2FLK14/AB-1756

System cabling for controllers

Controller-specific system cabling

Allen Bradley SLC 500 Front adapter

The front adapters mean that pre-assembled system cables can be directly connected to I/O modules.

- The FLKM 14-PA-SLC500... adapters connect max. 2 x 8 channels via two 14-pos. system cables. Tailor-made VARIOFACE termination boards with a variety of functions and connection options round off this system concept.
- With the FLKM50-PA-SLC500 OUT/2A front adapters, the FLKM 50/16/SLC500 termination board, and 50-position system cables, the VARIOFACE system cabling can also be coupled to the OA16 and OW16 power output cards.

Web code for the online configurator

i Your web code: **#0007**

Notes:
Standard modules from page 526
For system cables, see page 550



Front adapter for SLC 500 1746, 2 x 8 channels can be connected



Technical data

	FLKM 14-PA...	FLKM 50-PA...
Maximum permissible operating voltage	< 50 V AC / 60 V DC	< 50 V AC / 60 V DC
Maximum permissible operating voltage UL / CSA	125 V / -	125 V / -
Maximum permissible current	1 A (per path)	2 A (per path)
Maximum permissible total current	2 A (per Byte, for supply via connector)	7 A (per Byte, for supply via connector)
Ambient temperature (operation)	-20 °C ... 50 °C	-20 °C ... 50 °C
Ambient temperature (storage/transport)	-20 °C ... 70 °C	-20 °C ... 70 °C
Mounting position	any	any
Standards/regulations	IEC 60664 / DIN EN 50178	IEC 60664 / DIN EN 50178

Ordering data

Description	No. of pos.	Type	Order No.	Pcs./Pkt.
VARIOFACE front adapter , 2 x 8 channels can be connected for Allen Bradley SLC 500 for:				
- 1746 OB16, OV16, OG16 and IG16	14	FLKM 14-PA-SLC500/OUT	2293459	1
- 1746 IA16, IB16, ITB16 and IN16	14	FLKM 14-PA-SLC500/IN	2293462	1
- 1746 IV16 and IVT16	14	FLKM 14-PA-SLC500/IN/M	2293475	1
VARIOFACE front adapter , 1 x 16 channels can be connected for Allen Bradley SLC 500 1746 OA16 and OW16				
	50	FLKM 50-PA-SLC500/OUT/2A	2293446	1

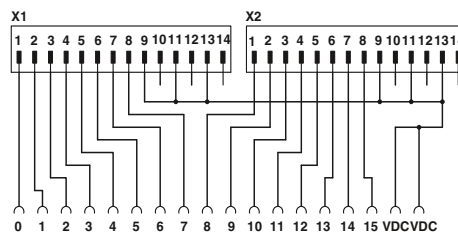

Connection scheme FLKM 14-PA-SLC500/IN/M

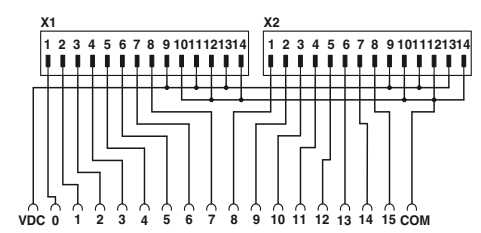

Connection scheme FLKM 14-PA-SLC500/OUT

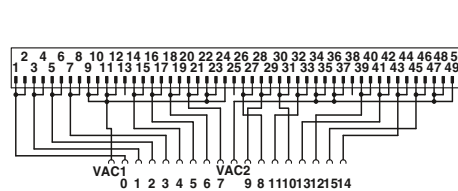

Connection scheme FLKM 50-PA-SLC500/OUT/2A

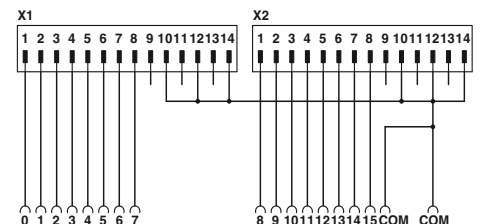

Connection scheme FLKM 14-PA-SLC500/IN

Explanation:

- IDC/FLK strip
- Connection to I/O card
- Screw terminal blocks for separate supply

VIP termination board for Allen Bradley SLC 500, 2 A output cards

The VIP-2/.../FLK50/16/SLC500 VARIOFACE Professional (VIP) module has been designed specifically for OA16 and OW16 output modules. Together with the FLKM 50-PA-SLC500/OUT/2A front adapter, currents up to 2 A per channel are transferred with the system cabling.

Notes:
For marking systems (e.g., "ZB 22:UNBEDRUCKT"; Order No. 0811862) and mounting material, see Catalog 3.

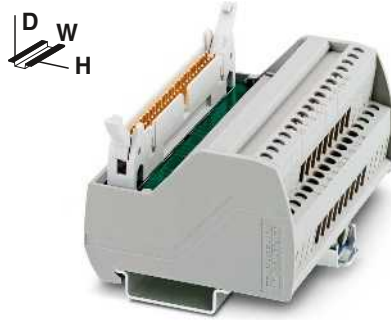

VARIOFACE termination board for 16 channels with screw connection

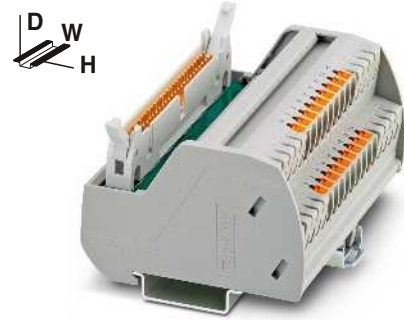

VARIOFACE termination board for 16 channels with Push-in connection



Technical data

Maximum permissible operating voltage	50 V AC / 60 V DC
Maximum permissible operating voltage UL / CSA	125 V / -
Maximum permissible current (per branch)	1 A
Maximum total current (voltage supply)	2 A (per channel)
Ambient temperature (operation)	-20 °C ... 50 °C
Mounting position	any
Standards/regulations	IEC 60664 , DIN EN 50178
Connection method	Field level Screw connection Controller level IDC/FLK pin strip
Connection data solid/stranded/AWG	0.2 ... 4 mm ² / 0.2 ... 2.5 mm ² / 24 - 12
Dimensions	H / D 65.5 mm / 56 mm

Technical data

Maximum permissible operating voltage	50 V AC / 60 V DC
Maximum permissible operating voltage UL / CSA	125 V / 125 V
Maximum permissible current (per branch)	1 A
Maximum total current (voltage supply)	2 A (per channel)
Ambient temperature (operation)	-20 °C ... 50 °C
Mounting position	any
Standards/regulations	EN 50178
Connection method	Field level Push-in connection Controller level IDC/FLK pin strip
Connection data solid/stranded/AWG	0.14 ... 2.5 mm ² / 0.14 ... 2.5 mm ² / 26 - 14
Dimensions	H / D 72.1 mm / 56 mm

Ordering data

Description	No. of pos.	Module width W
VARIOFACE termination board , for transfer of max. 16 channels, only in connection with FLKM 50-PA-SLC500 OUT/2A		
- with screw connection	50	90.8 mm
- with Push-in connection	50	92.7 mm

Type	Order No.	Pcs./ Pkt.
VIP-2/SC/FLK50/16/SLC500	2322320	1

Ordering data

Type	Order No.	Pcs./ Pkt.
VIP-2/PT/FLK50/16/SLC500	2904287	1

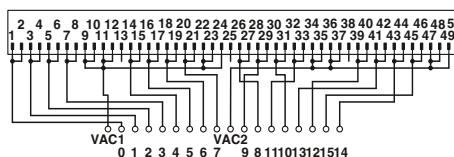

Connection scheme VIP-2/.../FLK50/16/SLC500

System cabling for controllers

Controller-specific system cabling

Allen Bradley SLC 500 System cable for 32 channels

The 32-channel I/O cards of the SLC 500 are connected using 40-pos. connectors (already integrated into the I/O modules). Passive termination boards (-3/SC/FLK40, etc.) are connected to the I/O cards using the **FLK 40/EZ-DR/.../SLC** system cables.

32 channels are split into 4x8 channels using the **FLK 40/4X14/EZ-DR/...** system cables.

The following 8-channel system cabling modules can be coupled:

- OB32 and IB32
passive and active modules plus V8 adapter
- OV32 and IV32
passive modules without status indicator

Web code for the online configurator

i Your web code: **#0007**

Notes:
Standard modules from page 526



**System cable for
32-channel I/O cards of the SLC 500
(OB32, OV32, IB32, IV32)**



Technical data

Maximum permissible operating voltage	< 50 V AC / 60 V DC
Maximum permissible operating voltage UL / CSA	125 V / -
Maximum permissible current carrying capacity per path	1 A
Ambient temperature (operation)	-20 °C ... 50 °C
Assembly	Insulation displacement, IEC 60352-4/DIN EN 60352-4
Conductor cross section	AWG 26 / 0.14 mm ²
Conductor structure: stranded wires / material	7 / Cu tin-plated
Outside diameter	10 mm

40-pos.

Ordering data

Description	No. of pos.	Cable length	Type	Order No.	Pcs./ Pkt.
Assembled round cable , with two 40-pos. IDC/FLK socket strips in fixed lengths (50 cm increments) for connection to 32-channel I/O cards of the SLC 500					
	40	0.5 m	FLK 40/EZ-DR/ 50/SLC	2294610	1
	40	1 m	FLK 40/EZ-DR/ 100/SLC	2294623	1
	40	1.5 m	FLK 40/EZ-DR/ 150/SLC	2294636	1
	40	2 m	FLK 40/EZ-DR/ 200/SLC	2294649	1
	40	3 m	FLK 40/EZ-DR/ 300/SLC	2294652	1
Assembled round cable , for connection to Allen Bradley SLC500, OB32, and IB32, with a 40-pos. IDC/FLK socket strip and four 14-pos. IDC/FLK socket strips, for splitting max. 32 channels into 4 x 8 channels.					
for OB32	40	0.5 m			
	40	1 m			
	40	2 m			
	40	3 m			
for IB32	40	0.5 m			
	40	1 m			
	40	2 m			
	40	3 m			



**System cable for
splitting max. 32 channels into 4 x 8 channels
(OB32, IB32)**



Technical data

< 50 V AC / 60 V DC
125 V / -

1 A

-20 °C ... 50 °C
Insulation displacement, IEC 60352-4/DIN EN 60352-4

AWG 26 / 0.14 mm²
7 / Cu tin-plated

7.8 mm

Ordering data

Type	Order No.	Pcs./ Pkt.
FLK 40/4X14/EZ-DR/ 50/OB32	2296786	1
FLK 40/4X14/EZ-DR/ 100/OB32	2298483	1
FLK 40/4X14/EZ-DR/ 200/OB32	2298522	1
FLK 40/4X14/EZ-DR/ 300/OB32	2298535	1
FLK 40/4X14/EZ-DR/ 50/IB32	2296812	1
FLK 40/4X14/EZ-DR/ 100/IB32	2296825	1
FLK 40/4X14/EZ-DR/ 200/IB32	2296838	1
FLK 40/4X14/EZ-DR/ 300/IB32	2296841	1

Controller-specific system cabling

Emerson DeltaV System cable

The DeltaV system can be used to install the process wiring via “mass termination blocks” (MTBs) using IDC/FLK connectors. In addition to the 10, 16, and 20-pos. system cables of system cabling (see page 550), the following system-specific cables are available:

- **FLK 16/14/DV-OUT/...**, for digital assemblies with 16-pos. MTB for connection with PLC-INTERFACE
- **FLK 16/14/DV-IN/...**, for digital modules with 16-pos. MTB for connection to PLC-INTERFACE
- **FLK 20/2FLK14/EZ-DR/...**, for digital assemblies with 40-pos. MTB for connection with PLC-INTERFACE
- **FLK 16/24/DV-AI/EZ-DR/...**, for analog assemblies with 24-pos. MTB
- **FLK 50/2FLK20/EZ-DR/.../DV** system cables are specifically designed for 32-channel I/O modules with 40-pin MTB for the purpose of connecting I/O modules with 32-channel VARIOFACE termination boards



System cable for DeltaV



Technical data

Maximum permissible operating voltage	< 50 V AC / 60 V DC
Maximum permissible operating voltage UL / CSA	125 V / -
Maximum permissible current carrying capacity per path	1 A
Maximum conductor resistance	0.16 Ω/m
Ambient temperature (operation)	-20 °C ... 50 °C
Conductor cross section	AWG 26 / 0.14 mm ²
Outside diameter	
	16-pos. 6.8 mm
	20-pos. 7.6 mm
	24-pos. 6.5 mm
	20-pos. 10.3 mm

Ordering data

Description	No. of pos.	Cable length	Type	Order No.	Pcs./ Pkt.
System cable, for 16-pos. “mass termination blocks” with a 16-pos. and a 14-pos. IDC/FLK socket strip for connection with PLC-INTERFACE					
	16	0.3 m	FLK 16/14/DV-OUT/ 30	2304348	1
	16	0.5 m	FLK 16/14/DV-OUT/ 50	2304351	1
	16	1 m	FLK 16/14/DV-OUT/100	2300575	1
	16	2 m	FLK 16/14/DV-OUT/200	2300588	1
	16	3 m	FLK 16/14/DV-OUT/300	2304364	1
Variable cable length	16		FLK 16-14-DV-OUT/...	2304377	1
System cable, for 16-pos. “mass termination blocks” with a 16-pos. and a 14-pos. IDC/FLK socket strip for connection with PLC-INTERFACE					
	16	0.5 m	FLK 16/14/DV-IN/ 50	2304393	1
	16	1 m	FLK 16/14/DV-IN/100	2300559	1
	16	2 m	FLK 16/14/DV-IN/200	2300562	1
	16	3 m	FLK 16/14/DV-IN/300	2304403	1
	16	4 m	FLK 16/14/DV-IN/400	2305185	1
Variable cable length	16		FLK 16-14-DV-IN/...	2304416	1
System cable, for 40-pos. (2 x 20) “mass termination blocks” with a 20-pos. and two 14-pos. IDC/FLK socket strips for connection with PLC-INTERFACE (two cables should be used per 32-channel I/O card)					
	20	1 m	FLK 20/2FLK14/EZ-DR/100/KONFEK	2298470	1
	20	2 m	FLK 20/2FLK14/EZ-DR/200/KONFEK	2298438	1
	20	3 m	FLK 20/2FLK14/EZ-DR/300/KONFEK	2300818	1
Variable cable length	20		FLK 20/2FLK14/EZ-DR/...	2304487	1
System cable, for 24-pos. “mass termination blocks” with a 24-pos. and a 16-pos. IDC/FLK socket strip for connection with UM-DELTA/... modules					
	24	0.3 m	FLK 16/24/DV-AI/EZ-DR/ 30	2304319	1
	24	0.5 m	FLK 16/24/DV-AI/EZ-DR/ 50	2304296	1
	24	1 m	FLK 16/24/DV-AI/EZ-DR/100	2301134	1
	24	2 m	FLK 16/24/DV-AI/EZ-DR/200	2301545	1
	24	3 m	FLK 16/24/DV-AI/EZ-DR/300	2304322	1
Variable cable length	24		FLK 16-24-DV-AI-EZ-DR/...	2304335	1
System cable, for 40-pos. “mass termination blocks” with two 20-pos. and one 50-pos. IDC/FLK socket strip for connection with 32-channel termination boards					
	20	0.5 m	FLK 50/2FLK20/EZ-DR/ 50/DV	2304872	1
	20	1 m	FLK 50/2FLK20/EZ-DR/ 100/DV	2304898	1
	20	2 m	FLK 50/2FLK20/EZ-DR/ 200/DV	2304908	1
	20	3 m	FLK 50/2FLK20/EZ-DR/ 300/DV	2304911	1
	20	6 m	FLK 50/2FLK20/EZ-DR/ 600/DV	2304937	1
	20	8 m	FLK 50/2FLK20/EZ-DR/ 800/DV	2304940	1
	20	10 m	FLK 50/2FLK20/EZ-DR/1000/DV	2304953	1
Variable cable length	20		FLK 50-2FLK20-EZ-DR-DV/...	2304966	1



Emerson DeltaV Termination board for eight channels

These system-specific termination boards for DeltaV modules are used in combination with the relevant system cables. They are connected to 8-channel modules via "mass termination blocks" with IDC/FLK connection.

FLKM 16/DV

- Universal module
- 1:1 connection

FLKM 16/AI/DV

- 1:1 connection
- Separate equipotential terminals per channel

FLKM 16/AO/SI/DV

- 1:1 connection
- 5 x 20, 50 mA T, IEC 60127-2/3 fuse per channel

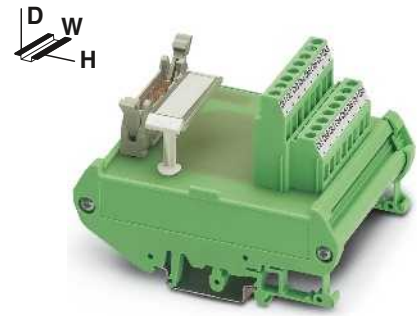

Termination board for 8 channels

Maximum permissible operating voltage
Maximum permissible current (per branch)

Ambient temperature (operation)
Mounting position
Standards/regulations
Connection method

Connection data solid/stranded/AWG
Dimensions

Field level
Controller level

Technical data

FLKM 16/.../DV	FLKM 16/.../SI/.../DV
< 50 V AC / 60 V DC	< 50 V AC / 60 V DC
1 A (per signal path)	50 mA (In delivered state, with one 50 mA fuse, max. 1 A permitted)

-20 °C ... 50 °C	-20 °C ... 50 °C
any	any
DIN EN 50178 , IEC 60664	
Screw connection	Screw connection
IDC/FLK pin strip	IDC/FLK pin strip
0.2 ... 4 mm ² / 0.2 ... 2.5 mm ² / 24 - 12	
90 mm / 68 mm	

Ordering data

Description	No. of pos.	Module width W	Type	Order No.	Pcs./ Pkt.
Termination board, with 1:1 connection			FLKM 16/DV	2304432	1
Termination board, with 1:1 connection and separate potential terminal blocks per channel	16	45 mm	FLKM 16/AI/DV	2304429	1
Termination board, with fuses per channel	16	57 mm	FLKM 16/AO/SI/DV	2304445	1
	16	90 mm			

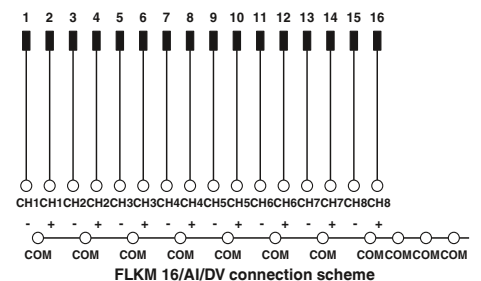
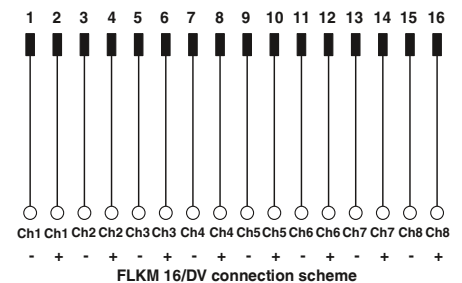
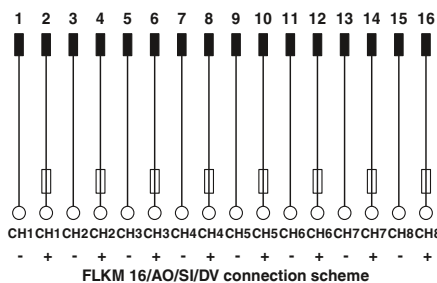

System cabling for controllers

Controller-specific system cabling

Emerson DeltaV

Termination board for 32 channels

These system-specific termination boards for DeltaV modules are used in combination with FLK 50/2FLK20/EZ-DR/.../DV system cables. They are connected to 32-channel modules via 40-pos. "mass termination blocks" with IDC/FLK connection.

FLKM 50/32M/DV

- Can be used for 32-channel input and output cards
- Two-conductor connection with a separate negative terminal per channel

FLKM 50/32M/IN/LA/DV

- Can be used for 32-channel input modules
- LED status display per channel
- Two-conductor connection with a separate negative terminal per channel (Dry Contact)

Maximum permissible operating voltage	Field level
Maximum permissible current (per branch)	Controller level
Ambient temperature (operation)	
Mounting position	
Standards/regulations	
Connection method	
Connection data solid/stranded/AWG	
Dimensions	H / D

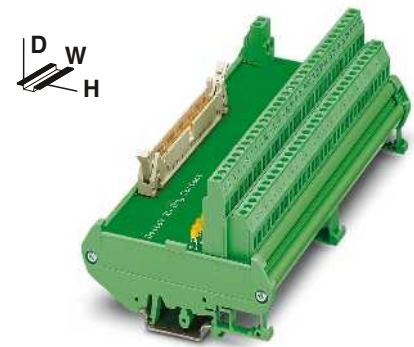

Termination board with 2-conductor connection technology for DeltaV

Technical data

FLKM 50/32M/DV	FLKM 50/32M/IN/LA/DV
< 50 V AC / 60 V DC	30 V DC
1 A	1 A
-20 °C ... 50 °C	-20 °C ... 50 °C
any	any
DIN EN 50178 , IEC 60664	
Screw connection	Screw connection
IDC/FLK pin strip	IDC/FLK pin strip
0.2 ... 4 mm ² / 0.2 ... 2.5 mm ² / 24 - 12	
90 mm / 68 mm	

Ordering data

Description	No. of pos.	Module width W
VARIOFACE termination boards, for 32-channel I/O modules:		
- Input/Output	50	169 mm
- Input with LED per signal	50	169 mm

Type	Order No.	Pcs./ Pkt.
FLKM 50/32M/DV	2304869	1
FLKM 50/32M/IN/LA/DV	2304856	1

Emerson DeltaV

VIP termination board with fuses for 8 channels

System-specific termination board for use in combination with the respective system cables. The termination board is connected to 8-channel modules through 16-position "mass termination blocks" with flat ribbon cable connection.

Features:

- Fuse per channel
- Separate equipotential terminals per channel
- Knife disconnection for each channel
- Push-in connection

Maximum permissible operating voltage	Field level
Maximum permissible operating voltage UL / CSA	Controller level
Maximum permissible current (per branch)	
Ambient temperature (operation)	
Mounting position	
Standards/regulations	
Connection method	
Connection data solid/stranded/AWG	
Dimensions	H / D

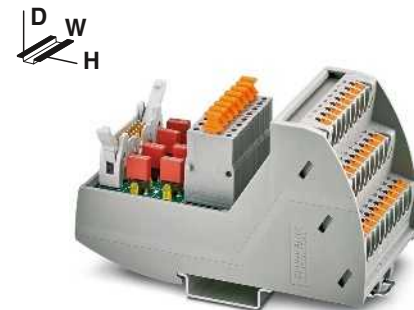

Termination board with fuses for 16-pos. mass termination block

Technical data

24 V DC	
24 V / 24 V	
63 mA (in as supplied state, with one 63 mA fuse)	
-20 °C ... 60 °C	
any	
DIN EN 50178	
Push-in connection	
IDC/FLK pin strip	
0.14 ... 2.5 mm ² / 0.14 ... 2.5 mm ² / 26 - 14	
109.8 mm / 63 mm	

Ordering data

Description	No. of pos.	Module width W
Termination board for 16-pos. mass termination block		
	16	57.1 mm

Type	Order No.	Pcs./ Pkt.
VIP-PT/FLK16/DS/FU/LED/AN/DV	2903599	1

Emerson DeltaV Termination boards with fuses for 8 channels

These system-specific termination boards for DeltaV modules are used in combination with the relevant system cables. They are connected to 8-channel modules via 16-pos. or 24-pos. "mass termination blocks" with IDC/FLK connection.

UM-DELTA V/D/SI

- Fuse per channel
- Separate equipotential terminals per channel

UM-DELTA V/D/SI

- Fuse per channel
- Separate equipotential terminals per channel
- Knife disconnection for each channel

UM-DELTA V/D/SI/BFI/TP

- Fuse and LED status indicator per channel
- Separate equipotential terminals per channel

UM-DELTA V/D/SI

- Fuse and LED status indicator per channel
- Separate equipotential terminals per channel
- Knife disconnection for each channel

Maximum permissible operating voltage
Maximum permissible operating voltage UL / CSA

Maximum permissible current (per branch)

Ambient temperature (operation)

Mounting position
Standards/regulations

Connection method

Connection data solid/stranded/AWG

Dimensions

Field level
Controller level

24 V DC

24 V / -

50 mA (in as-supplied state, with one 50 mA fuse, max. 1 A permitted)

-20 °C ... 50 °C

any

IEC 60664 , DIN EN 50178

Screw connection

IDC/FLK pin strip

0.2 ... 4 mm² / 0.2 ... 2.5 mm² / 24 - 12

126 mm / 71 mm

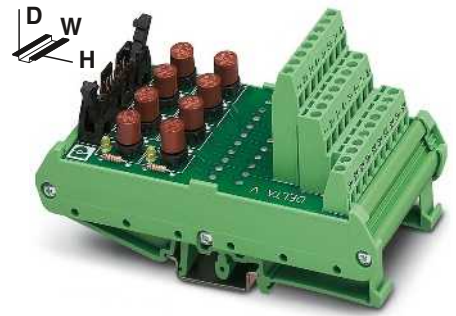

Termination board with fuses for 16-pos. and 24-pos. mass termination blocks

Technical data

Ordering data

Description	No. of pos.	Module width W
Termination boards for 16-pos. and 24-pos. mass termination blocks with:		
- Fuses	16	61 mm
- Fuses and knife disconnect terminal blocks	16	61 mm
- Fuses and fuse failure display	16	61 mm
- Fuses, fuse failure display, and knife disconnect terminal blocks	16	61 mm

Type	Order No.	Pcs./ Pkt.
UM-DELTA V/D/SI	5603255	1
UM-DELTA V/D/SI/BFI/TP	5603257	1
UM-DELTA V/A/SI	5603256	1
UM-DELTA V/A/SI/BFI/TP	5603258	1

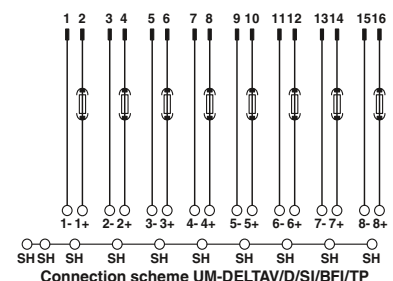
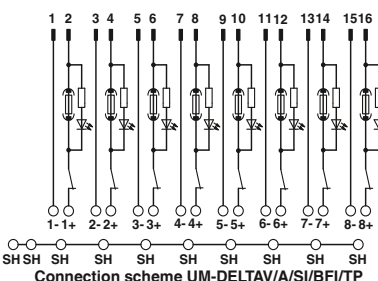
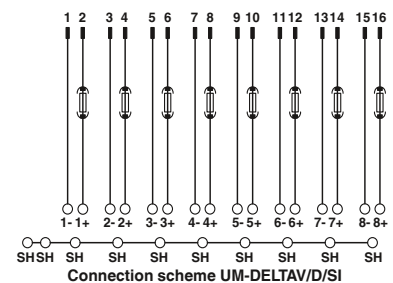
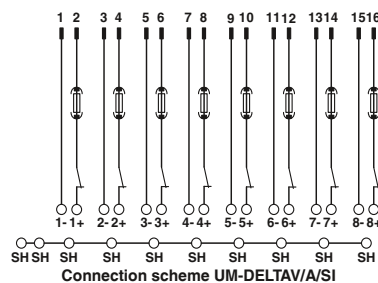

Explanation:

- IDC/FLK strip
- Connection to I/O card
- Screw terminal blocks for separate supply

Controller-specific system cabling

GE Fanuc RX3i Front adapters

The front adapters mean that pre-assembled system cables can be directly connected to I/O modules.

- Transfer of max. 32 channels over one 50-position system cable
- Can be plugged onto I/O modules
- Connection via suitable VARIOFACE termination boards

Web code for the online configurator

i Your web code: **#0007**

Notes:
Standard modules from page 526
For system cables, see page 550



Front adapter for GE Fanuc RX3i

ERC

Technical data

Maximum permissible operating voltage
Maximum permissible current

< 50 V AC / 60 V DC
1 A (per path)
8 A (per connection, supply via separate power supply)

Ambient temperature (operation)
Ambient temperature (storage/transport)
Mounting position
Standards/regulations

-20 °C ... 50 °C
-20 °C ... 70 °C
any
DIN EN 50178 / IEC 60664

Ordering data

Description	No. of pos.
VARIOFACE front adapter , for PACSystems RX3i,	
For digital output and analog modules	50
For digital input modules	50

Type	Order No.	Pcs./Pkt.
FLKM 50-PA-GE/TKFC/RXI	2321473	1
FLKM 50-PA-GE/TKFC/RXI/IN	2321486	1

Front adapters for I/O modules of the RX3i series

Card type	FLKM 50-PA-GE/TKFC/RXI
Digital output	IC 694 MDL 754

Card type	FLKM 50-PA-GE/TKFC/RXI/IN
Digital input	IC 694 MDL 660

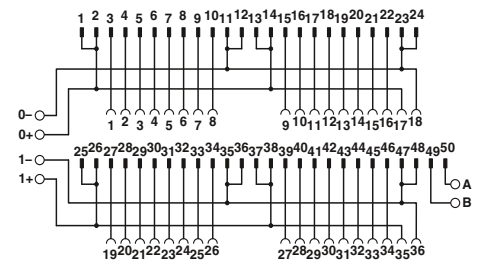

Connection scheme for FLKM 50-PA-GE/TKFC/RXI

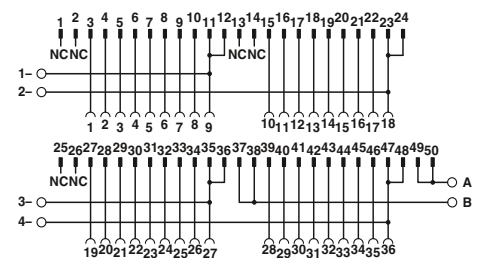

Connection scheme for FLKM 50-PA-GE/TKFC/RXI/IN

Explanation:
 IDC/FLK strip
 Connection to I/O card
 Screw terminal blocks for separate supply

GE Fanuc, Series 90-30

Front adapters

The front adapters mean that pre-assembled system cables can be directly connected to I/O modules.

Up to 2 x 8 channels are connected via two 14-pos. system cables.

Tailor-made VARIOFACE termination boards with a variety of functions and connection options round off this system concept.

Web code for the online configurator

i Your web code: **#0007**

Notes:

Standard modules from page 526

For system cables, see page 550



Front adapter for GE Fanuc Series 90-30



Technical data

Maximum permissible operating voltage
Maximum permissible current

< 50 V AC / 60 V DC
1 A (per path)
4 A (per connection, supply via separate power supply)

Maximum permissible total current

3 A (per Byte, for supply via connector)

Ambient temperature (operation)
Ambient temperature (storage/transport)
Mounting position
Standards/regulations

-20 °C ... 50 °C
-20 °C ... 70 °C
any
IEC 60664 / DIN EN 50178

Ordering data

Description	No. of pos.
VARIOFACE front adapter , for Series 90-30, max. 2 x 8 channels can be connected, digital output	14
VARIOFACE front adapter , for Series 90-30, max. 2 x 8 channels can be connected, digital input	14

Type	Order No.	Pcs./Pkt.
FLKM 14-PA/GE/DO	2290009	2
FLKM 14-PA/GE/DI	2290038	5

Front adapters for I/O modules of the Series 90-30

Card type	FLKM 14-PA/GE/DO
Digital output	IC 693 MDL 732 IC 693 MDL 733* IC 693 MDL 740 IC 693 MDL 741* IC 693 MDL 742
Analog	IC 693 ALG 220* IC 693 ALG 221* IC 693 ALG 222* IC 693 ALG 223* IC 693 ALG 390* IC 693 ALG 391* IC 693 ALG 392* IC 693 ALG 442*

Card type	FLKM 14-PA/GE/DI
Digital input	IC 693 MDL 241 IC 693 MDL 634 IC 693 MDL 645 IC 693 MDL 646

* Only in conjunction with VIP-2/SC/2FLK14(1-20)/S7, Order No.: 2315230 and UM 45-2FLK14/ZFKDS/S7, Order No.: 2965156. All wire bridges (DR) on the adapter must be disconnected. There must be no voltage supply at the front adapter (flowing via the slip-on connections).

Explanation:
 IDC/FLK strip
 Connection to I/O card
 Screw terminal blocks for separate supply

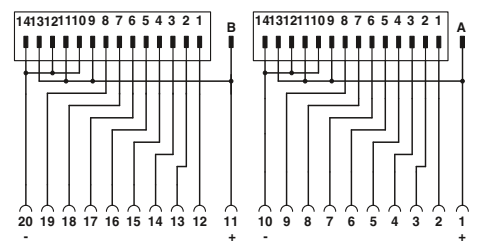

Connection scheme FLKM 14-PA/GE/DO

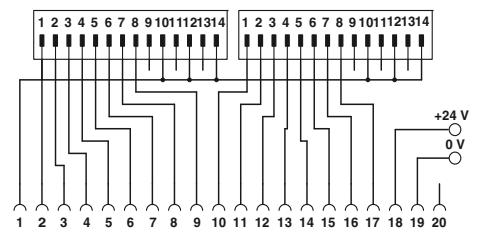

Connection scheme FLKM 14-PA/GE/DI

System cabling for controllers

Controller-specific system cabling

Honeywell C300, Series C I/O Front adapters

The front adapters mean that pre-assembled system cables can be directly connected to I/O modules.

FLKM-PA-D37/HW/DIO/C300

- Front adapter with D-SUB connector
- Connection of a maximum of 16 digital channels
- Specifically for digital I/O cards

FLKM-PA-D37/HW/AN/C300

- Front adapter with D-SUB connector
- Connection of analog modules

FLKM-PA-2D15/HW/.../C300

- Front adapter with two 15-pos. D-SUB connectors
- Connection of a maximum of 2 x 8 digital inputs/outputs per adapter
- Specifically for connecting PLC-V8/D15.../OUT or PLC-V8/D15.../IN

Web code for the online configurator

i Your web code: #0007

Notes:
Matching system cable fitted with D-SUB socket strip at both ends, see page 593
1) No UL approval



Honeywell C300 front adapter



Technical data

Maximum permissible operating voltage	60 V DC
Maximum permissible operating voltage UL / CSA	125 V / -
Maximum permissible current	1 A (per path)
Ambient temperature (operation)	-20 °C ... 50 °C
Ambient temperature (storage/transport)	-20 °C ... 70 °C
Mounting position	any
Standards/regulations	IEC 60664 / DIN EN 50178

Ordering data

Description	No. of pos.
VARIOFACE front adapter for C I/O series, with one D-SUB pin strip	
- For digital I/O modules	37
- For analog I/O modules	37
VARIOFACE front adapter for C I/O series, with two D-SUB pin strips	
- For digital output modules	15
- For digital input modules	15

Type	Order No.	Pcs./Pkt.
FLKM-PA-D37/HW/DIO/C300	2901423	1
FLKM-PA-D37/HW/AN/C300	2900622	1
FLKM-PA-2D15/HW/DO/C300 ¹⁾	2900924	1
FLKM-PA-2D15/HW/DI/C300 ¹⁾	2901879	1

Front adapters for I/O modules of the C300 and C I/O series

Card type	FLKM-PA-D37/HW/DIO/C300
Digital input	TDIL 11* TDIL 01*
Digital output	TDOB 11* TDOB 01*

Card type	FLKM-PA-D37/HW/AN/C300
Analog input	TAIX 01** TAIX 11**
Analog output	TAOX 01** TAOX 11**

Card type	FLKM-PA-2D15/HW/DO/C300
Digital output	TDOB 01* TDOB 11*

Card type	FLKM-PA-2D15/HW/DI/C300
Digital input	TDIL 01* TDIL 11*

* Two front adapters are required for each module.

** For three-conductor operation (channels 13 - 16) of input modules: only in conjunction with VIP-3/SC/D37SUB/M/HW/C300, Order No.: 2900675.

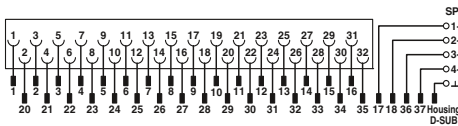

Connection scheme: FLKM-PA-D37/HW/AN/C300

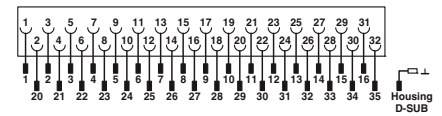

Connection scheme: FLKM-PA-D37/HW/DIO/C300

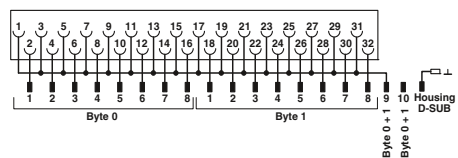

FLKM-PA-2D15/HW/DI/C300 connection scheme

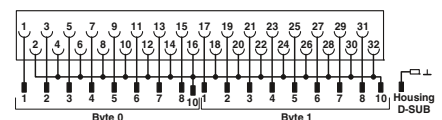

Connection scheme: FLKM-PA-2D15/HW/DO/C300

Explanation:

- Connectors
- Connection to I/O card
- Screw terminal blocks for separate supply

Honeywell C300, Series C I/O termination boards

These VIP - VARIOFACE Professional modules are used in combination with 37-pos. D-SUB cables and the relevant front adapters. The three module versions are available with screw or Push-in connection technology.

VIP-2/.../D37SUB/M

- In conjunction with FLKM-PA-D37/HW/C300 or FLKM-PA-D37/HW/AN/C300 front adapter
- Universal module
- Field connection via double-level terminal blocks

VIP-2/.../D37SUB/M/SO

- In conjunction with FLKM-PA-D37/HW/C300 front adapter
- System-specific marking
- Field connection via double-level terminal blocks

VIP-3/.../D37SUB/M/HW/C300

- In conjunction with FLKM-PA-D37/HW/AN/C300 front adapter
- System-specific marking
- For TAIX01, TAIX11 analog input modules
- Field connection via three-level terminal blocks

Web code for the online configurator

i Your web code: **#0007**

Notes:

For marking systems (e.g., "ZB 22:UNBEDRUCKT"; Order No. [0811862](#)) and mounting material, see Catalog 3.

¹⁾ No UL approval

Maximum permissible operating voltage	
25 V AC / 60 V DC	
Maximum permissible operating voltage UL / CSA	
125 V / 105 V	
Maximum permissible current (per branch)	
2 A	
Ambient temperature (operation)	
-20 °C ... 50 °C	
Mounting position	
any	
Standards/regulations	
DIN EN 50178	
Connection method	Controller level
D-SUB pin strip	D-SUB pin strip
Screw connection solid/stranded/AWG	0.2 ... 4 mm ² / 0.2 ... 2.5 mm ² / 24 - 12
Push-in connection solid/stranded/AWG	0.14 ... 4 mm ² / 0.14 ... 2.5 mm ² / 26 - 14
Dimensions	H / D
72.1 mm / 46.6 mm	75.8 mm / 63 mm

Description	No. of pos.	Module width W
VARIOFACE termination board , with D-SUB pin strip and universal marking,		
- with screw connection	37	101 mm
- with Push-in connection	37	102.8 mm
VARIOFACE termination board , with D-SUB pin strip and system-specific marking,		
- with screw connection	37	101 mm
- with Push-in connection	37	102.8 mm
VARIOFACE termination board , with D-SUB pin strip for analog input modules,		
- with screw connection	37	88 mm
- with Push-in connection	37	87.6 mm

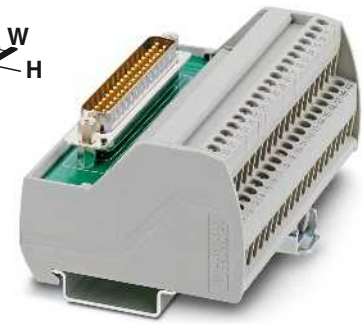

37-pos. with screw or Push-in connection



Technical data

VIP-2/...	VIP-3/...C300
25 V AC / 60 V DC	25 V AC / 60 V DC
125 V / 105 V	125 V / 105 V
2 A	2 A
-20 °C ... 50 °C	-20 °C ... 50 °C
any	any
DIN EN 50178	
D-SUB pin strip	D-SUB pin strip
0.2 ... 4 mm ² / 0.2 ... 2.5 mm ² / 24 - 12	
0.14 ... 4 mm ² / 0.14 ... 2.5 mm ² / 26 - 14	
72.1 mm / 46.6 mm	75.8 mm / 63 mm

Ordering data

Type	Order No.	Pcs./ Pkt.
VIP-2/SC/D37SUB/M	2900676	1
VIP-2/PT/D37SUB/M	2904277	1
VIP-2/SC/D37SUB/M/SO ¹⁾	2900786	1
VIP-2/PT/D37SUB/M/SO ¹⁾	2904278	1
VIP-3/SC/D37SUB/M/HW/C300	2900675	1
VIP-3/PT/D37SUB/M/HW/C300	2904276	1

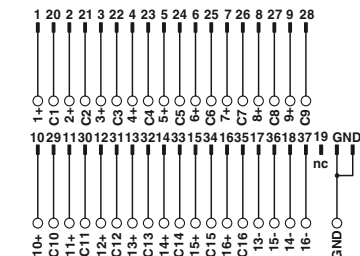

Connection scheme VIP-3/SC/D37SUB/M/HW/C300

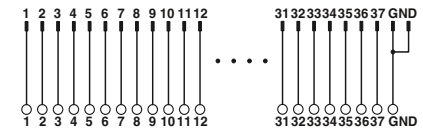

Connection scheme VIP-2/SC/D37SUB/M

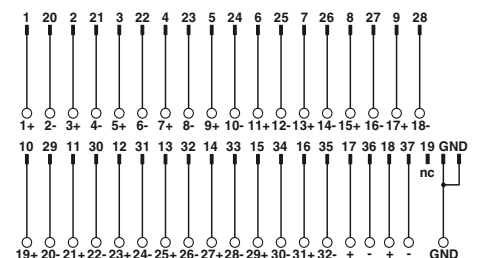

Connection scheme VIP-2/SC/D37SUB/M/SO

System cabling for controllers

Controller-specific system cabling

Mitsubishi Electric MELSEC A, A1S and Q System cables

For 32/64-channel I/O cards with 37-pos. D-SUB connectors. System cables are available for connecting 1 x 32 channels or 4 x 8 channels.

Web code for the online configurator

i Your web code: #0007



**System cable,
D-SUB socket strip to IDC/FLK socket strip,
number of positions: 37 to 50**



Technical data

Maximum permissible operating voltage	< 50 V AC / 60 V DC
Maximum permissible operating voltage UL / CSA	125 V / -
Maximum permissible current carrying capacity per path	1 A
Maximum conductor resistance	0.16 Ω/m
Ambient temperature (operation)	-20 °C ... 50 °C
Conductor cross section	AWG 26 / 0.14 mm ²
Conductor structure: stranded wires / material	7 / Cu tin-plated
Outside diameter	10.5 mm

37-pos.

Ordering data

Description	No. of pos.	Cable length	Type	Order No.	Pcs./ Pkt.
Round cable for output module MELSEC Q Y81 P, MELSEC A1S Y81, and MELSEC A AY82EP, in standard lengths	37	0.5 m	FLK 50/EZ-DR/D37SUB/ 50/Y81P-O	2302599	1
	37	1 m	FLK 50/EZ-DR/D37SUB/100/Y81P-O	2302609	1
	37	2 m	FLK 50/EZ-DR/D37SUB/200/Y81P-O	2302612	1
	37	3 m	FLK 50/EZ-DR/D37SUB/300/Y81P-O	2302638	1
	37		FLK 50-EZ-DR-D37SUB-Y81P-O/...	2302625	1
Round cable for input module MELSEC Q X81, MELSEC A1S X81, and MELSEC A AX82, in standard lengths	37	0.5 m	FLK 50/EZ-DR/D37SUB/ 50/X81-I	2302641	1
	37	1 m	FLK 50/EZ-DR/D37SUB/100/X81-I	2302654	1
	37	2 m	FLK 50/EZ-DR/D37SUB/200/X81-I	2302667	1
	37	3 m	FLK 50/EZ-DR/D37SUB/300/X81-I	2302670	1
	37		FLK 50-EZ-DR-D37SUB-X81-I/...	2302683	1



**Splitting cable,
D-SUB socket strip to IDC/FLK socket strip,
number of positions: 37 to 4 x 14**



Technical data

Maximum permissible operating voltage	< 50 V AC / 60 V DC
Maximum permissible operating voltage UL / CSA	125 V / -
Maximum permissible current carrying capacity per path	1 A
Maximum conductor resistance	0.16 Ω/m
Ambient temperature (operation)	-20 °C ... 50 °C
Conductor cross section	AWG 26 / 0.14 mm ²
Conductor structure: stranded wires / material	7 / Cu tin-plated
Outside diameter	6.3 mm

Ordering data

Description	No. of pos.	Cable length	Type	Order No.	Pcs./ Pkt.
Round cable, as above, but in variable lengths	37		CABLE-D37-M2,5/4X14/ 50/Y81P-O	2302476	1
	37		CABLE-D37-M2,5/4X14/100/Y81P-O	2302489	1
	37		CABLE-D37-M2,5/4X14/200/Y81P-O	2302492	1
	37		CABLE-D37-M2,5/4X14/300/Y81P-O	2302502	1
	37		CABLE-D37-M2,5-4X14-Y81P-O/...	2302696	1
Round cable, as above, but in variable lengths	37		CABLE-D37-M2,5/4X14/ 50/X81-I	2302515	1
	37		CABLE-D37-M2,5/4X14/100/X81-I	2302528	1
	37		CABLE-D37-M2,5/4X14/200/X81-I	2302531	1
	37		CABLE-D37-M2,5/4X14/300/X81-I	2302544	1
	37		CABLE-D37-M2,5-4X14-X81-I/...	2302706	1

Ordering example for system cable:

– Cable for MELSEC Q Y81P, 12.75 m long

Quantity	Order No.	Length [m] ¹⁾
1	2302625	12.75

¹⁾ min. 0.20 m

Ordering example for splitting cable:

– Cable for MELSEC Q Y81P, 11.00 m long

Quantity	Order No.	Length [m] ¹⁾
1	2302696	11.00

¹⁾ min. 0.20 m

Mitsubishi Electric MELSEC L/Q and Honeywell ML 200 System cables

These system cables are plugged onto the I/O cards that are connected using Fujitsu connectors.

CABLE-FCN40/1X50/...

– Signal transmission of 32 channels

CABLE-FCN40/4X14/...

– Splitting up 32 channels into
4 x 8 channels

Web code for the online configurator

 Your web code: #0007



Fujitsu FCN connector to
IDC/FLK socket strip,
number of positions: 40 to 50



Fujitsu FCN connector to
IDC/FLK socket strip,
number of positions: 40 to 4 x 14



Maximum permissible operating voltage
Maximum permissible operating voltage UL / CSA

Maximum permissible current carrying capacity per path

Maximum conductor resistance

Ambient temperature (operation)

Conductor cross section

Conductor structure: stranded wires / material

< 50 V AC / 60 V DC
125 V / -

1 A

0.16 Ω/m

-20 °C ... 50 °C

AWG 26 / 0.14 mm²

7 / Cu tin-plated



< 50 V AC / 60 V DC
125 V / -

1 A

0.16 Ω/m

-20 °C ... 50 °C

AWG 26 / 0.14 mm²

7 / Cu tin-plated

Technical data

Technical data

Ordering data

Ordering data

Description	No. of pos.	Cable length	Type	Order No.	Pcs./ Pkt.	Type	Order No.	Pcs./ Pkt.
Round cable in variable lengths for Mitsubishi MELSEC L LX41C4, LX42C4 (common positive connection to B01, B02) LY41NT1P, LY42NT1P, LY41PT1P, LY42PT1P Mitsubishi MELSEC Q QX41, QX41-S1, QX42, QX42-S1 QX71 and QX72 (common positive connection to B01, B02) QY41P, QY42P, QY71, QH42P Honeywell ML 200 2MLQ-TR4A, 2MLQ-TR8A, 2MLQ-TR4B, 2MLQ-TR8B	40	0.5 m	CABLE-FCN40/1X50/ 0,5M/IM/MEL	2903468	1			
	40	1 m	CABLE-FCN40/1X50/ 1,0M/IM/MEL	2903469	1			
	40	2 m	CABLE-FCN40/1X50/ 2,0M/IM/MEL	2903470	1			
	40	3 m	CABLE-FCN40/1X50/ 3,0M/IM/MEL	2903471	1			
	40	4 m	CABLE-FCN40/1X50/ 4,0M/IM/MEL	2903472	1			
	40	6 m	CABLE-FCN40/1X50/ 6,0M/IM/MEL	2903473	1			
	40	8 m	CABLE-FCN40/1X50/ 8,0M/IM/MEL	2903474	1			
	40	10 m	CABLE-FCN40/1X50/10,0M/IM/MEL	2903475	1			
Round cable in variable lengths for Mitsubishi MELSEC L LX41C4 and LX42C4 (common negative connection to B01, B02) Mitsubishi MELSEC Q QX71 and QX72 (common negative connection to B01, B02) QX82, QX82-S1 Honeywell ML 200 2MLI-D24A, 2MLI-D28B, 2MLF-SOEA (common negative connection to B01, B02)	40	0.5 m	CABLE-FCN40/1X50/ 0,5M/IP/MEL	2903476	1			
	40	1 m	CABLE-FCN40/1X50/ 1,0M/IP/MEL	2903477	1			
	40	2 m	CABLE-FCN40/1X50/ 2,0M/IP/MEL	2903478	1			
	40	3 m	CABLE-FCN40/1X50/ 3,0M/IP/MEL	2903479	1			
	40	4 m	CABLE-FCN40/1X50/ 4,0M/IP/MEL	2903480	1			
	40	6 m	CABLE-FCN40/1X50/ 6,0M/IP/MEL	2903481	1			
	40	8 m	CABLE-FCN40/1X50/ 8,0M/IP/MEL	2903482	1			
	40	10 m	CABLE-FCN40/1X50/10,0M/IP/MEL	2903483	1			
Round cable in variable lengths for Mitsubishi MELSEC L LX41C4 and LX42C4 (common positive connection to B01, B02) LY41NT1P, LY42NT1P, LY41PT1P, LY42PT1P Mitsubishi MELSEC Q QX41, QX41-S1, QX42, QX42-S1 QY41P (24 V), QY42P (24 V), QH42P (24 V) Honeywell ML 200 2MLQ-TR4A, 2MLQ-TR8A, 2MLQ-TR4B, 2MLQ-TR8B	40	0.5 m	CABLE-FCN40/4X14/ 0,5M/IM/MEL	2903502	1			
	40	1 m	CABLE-FCN40/4X14/ 1,0M/IM/MEL	2903503	1			
	40	2 m	CABLE-FCN40/4X14/ 2,0M/IM/MEL	2903504	1			
	40	3 m	CABLE-FCN40/4X14/ 3,0M/IM/MEL	2903505	1			
	40	4 m	CABLE-FCN40/4X14/ 4,0M/IM/MEL	2903506	1			
	40	6 m	CABLE-FCN40/4X14/ 6,0M/IM/MEL	2903507	1			
	40	8 m	CABLE-FCN40/4X14/ 8,0M/IM/MEL	2903508	1			
	40	10 m	CABLE-FCN40/4X14/10,0M/IM/MEL	2903509	1			

System cabling for controllers

Controller-specific system cabling

OMRON CJ1, CS1, CQM1 and C200H System cables

These system cables are plugged onto the I/O cards that are connected using Fujitsu connectors.

FLK 50/EZ-DR/...

– Signal transmission of 32 channels

CABLE-FCN40...

– Splitting up 32 channels into
4 x 8 channels

CABLE-FCN24...

– Splitting up 16 channels into
2 x 8 channels



Fujitsu FCN connector to IDC/FLK socket strip, number of positions: 40 to 50



Technical data

Maximum permissible operating voltage	< 50 V AC / 60 V DC
Maximum permissible operating voltage UL / CSA	125 V / -
Maximum permissible current carrying capacity per path	1 A
Maximum conductor resistance	0.16 Ω/m
Ambient temperature (operation)	-20 °C ... 50 °C
Conductor cross section	AWG 26 / 0.14 mm ²
Conductor structure: stranded wires / material	7 / Cu tin-plated

Ordering data

Description	No. of pos.	Cable length
Round cable in variable lengths for CJ1: OD231, OD261 CS1, C200H: OD218, OD219 CQM1: OD213	40 40	1 m 2 m
Round cable , as above, but in variable lengths	40	
Round cable in variable lengths for CJ1: ID231, ID261 CS1 and C200H: ID111, ID216, ID217, CQM1: ID213; ID214; ID112	40 40	1 m 2 m
Round cable , as above, but in variable lengths	40	
Round cable in variable lengths for CS1, C200H: OD215, MD115 (only output), MD215 (only output)	24 24	1 m 2 m
Round cable , as above, but in variable lengths	24	
Round cable in variable lengths for CS1, C200H: ID215, MD115 (only input), MD215 (only input)	24 24	1 m 2 m
Round cable , as above, but in variable lengths	24	



Fujitsu FCN connector to IDC/FLK socket strip, number of positions: 40 to 4 x 14 or 24 to 2 x 14



Technical data

Maximum permissible operating voltage	< 50 V AC / 60 V DC
Maximum permissible operating voltage UL / CSA	125 V / -
Maximum permissible current carrying capacity per path	1 A
Maximum conductor resistance	0.16 Ω/m
Ambient temperature (operation)	-20 °C ... 50 °C
Conductor cross section	AWG 26 / 0.14 mm ²
Conductor structure: stranded wires / material	7 / Cu tin-plated

Ordering data

Type	Order No.	Pcs./ Pkt.
FLK 50/EZ-DR/FCN40/100/OMR-OUT	2304144	1
FLK 50/EZ-DR/FCN40/200/OMR-OUT	2304157	1
FLK 50-EZ-DR-FCN40-OMR-OUT/...	2302829	1
FLK 50/EZ-DR/FCN40/100/OMR-IN	2304160	1
FLK 50/EZ-DR/FCN40/200/OMR-IN	2304173	1
FLK 50-EZ-DR-FCN40-OMR-IN/...	2302803	1
CABLE-FCN40/4X14/100/OMR-OUT	2304186	1
CABLE-FCN40/4X14/200/OMR-OUT	2304199	1
CABLE-FCN40-4X14-OMR-OUT/...	2302832	1
CABLE-FCN40/4X14/100/OMR-IN	2304209	1
CABLE-FCN40/4X14/200/OMR-IN	2304212	1
CABLE-FCN40-4X14-OMR-IN/...	2302816	1
CABLE-FCN24/2X14/100/OMR-OUT	2304225	1
CABLE-FCN24/2X14/200/OMR-OUT	2304238	1
CABLE-FCN24-2X14-OMR-OUT/...	2302858	1
CABLE-FCN24/2X14/100/OMR-IN	2304241	1
CABLE-FCN24/2X14/200/OMR-IN	2304254	1
CABLE-FCN24-2X14-OMR-IN/...	2302845	1

Ordering example for system cable:

– Cable for OMRON CJ1, ID231, 12.75 m long

Quantity	Order No.	Length [m] ¹⁾
1	2302803	12.75

¹⁾ min. 0.20 m

Phoenix Contact Axioline real-time I/O System cables

These cables have been specifically developed for connecting VARIOFACE termination boards to the Axioline real-time I/O system. The Push-in technology on the I/O system ensures rapid connection.

The cables have the following features:

- 1:1 connection
- 14-pos. connector, encapsulated
- 8 pre-assembled open ends, for connection to the Axioline real-time I/O system
- Transmission of groups of 8 channels
- Tailor-made VARIOFACE termination boards round off this system concept.

Notes:
 The following modules cannot be coupled due to the larger outer contour of the encapsulated connectors:
 UM 45-FLK14/ 8IM/ZFKDS/PLC, [2965211](#)
 UM 45- 8RM/MR-G24/1/PLC, [2962900](#)



System cable for 8 channels



Technical data

Maximum permissible operating voltage	< 50 V AC / 60 V DC
Maximum permissible operating voltage UL / CSA	125 V / -
Maximum permissible current carrying capacity per path	1 A
Maximum conductor resistance	0.16 Ω/m
Ambient temperature (operation)	-20 °C ... 50 °C
Assembly	Insulation displacement, IEC 60352-4/DIN EN 60352-4
Conductor cross section	AWG 26 / 0.14 mm ²
Conductor structure: stranded wires / material	7 / Cu tin-plated
Outside diameter	6.4 mm

Ordering data

Description	No. of pos.	Cable length	Type	Order No.	Pcs./ Pkt.
Round cable with an open end (8 individual wires)					
	8	0.5 m	VIP-CAB-FLK14/AXIO/0,14/0,5M	2901604	1
	8	1 m	VIP-CAB-FLK14/AXIO/0,14/1,0M	2901605	1
	8	1.5 m	VIP-CAB-FLK14/AXIO/0,14/1,5M	2901606	1
	8	2 m	VIP-CAB-FLK14/AXIO/0,14/2,0M	2901607	1
	8	2.5 m	VIP-CAB-FLK14/AXIO/0,14/2,5M	2901608	1
	8	3 m	VIP-CAB-FLK14/AXIO/0,14/3,0M	2901609	1
	8	4 m	VIP-CAB-FLK14/AXIO/0,14/4,0M	2901610	1
	8	6 m	VIP-CAB-FLK14/AXIO/0,14/6,0M	2901611	1



System cabling for controllers

Controller-specific system cabling

Phoenix Contact Inline Front adapters

The front adapters are used to connect pre-assembled system cables directly to Inline. Front adapters are simply plugged into the relevant Inline modules. Three connection options are available:

- Transfer of 8 channels via a 14-pos. system cable
 - Transmission of 2 x 8 channels over two 14-position system cables
 - Transmission of 4 x 8 channels over four 14-position system cables
- Tailor-made VARIOFACE termination boards round off this system concept.

Web code for the online configurator

i Your web code: **#0007**

Notes:
Standard modules from page 526
For system cables, see page 550



Front adapters for Inline



Maximum permissible operating voltage
Maximum permissible current
Ambient temperature (operation)
Ambient temperature (storage/transport)
Mounting position
Standards/regulations

60 V DC
1 A (per path)
-20 °C ... 50 °C
-20 °C ... 70 °C
any
IEC 60664 / DIN EN 50178

Description	No. of pos.
VARIOFACE front adapter, for 8-channel Inline modules	
Input: IB IL 24 D I8/HD-PAC Output: IB IL 24 DO 8/HD-PAC	14
VARIOFACE front adapter, for 16-channel Inline modules	
Input: IB IL 24 DI 16-PAC Output: IB IL 24 DO 16-PAC	14
VARIOFACE front adapter, for 32-channel Inline modules	
Input: IB IL 24 DI 32/HD-PAC and IB IL 24 DI 32/HD-NPN-PAC Output: IB IL 24 DO 32/HD-PAC	14

Technical data

Ordering data

Type	Order No.	Pcs./Pkt.
FLKM 14-PA-INLINE/DIO8	2900889	1
FLKM 14-PA-INLINE/IN16	2302751	1
FLKM 14-PA-INLINE/OUT16	2302764	1
FLKM 14-PA-INLINE/32	2302777	1

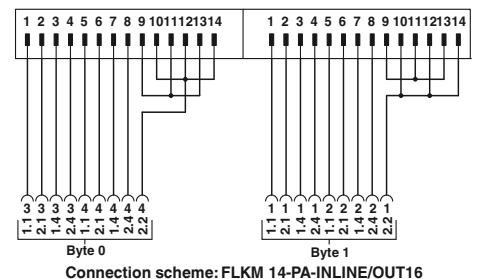
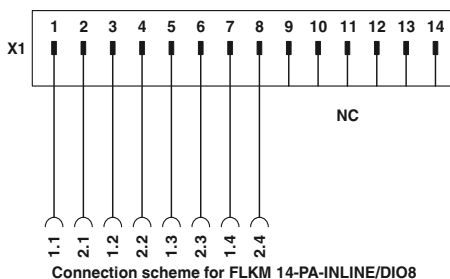
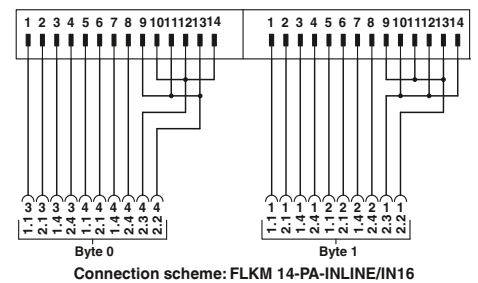
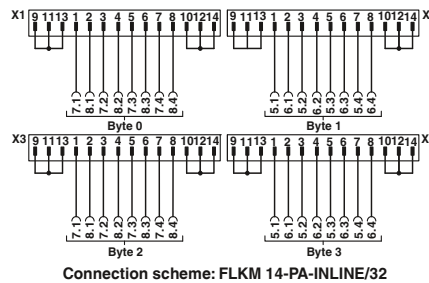

Explanation:
 IDC/FLK strip
 Connection to I/O card
 Screw terminal blocks for separate supply

Schneider Electric Modicon TSX Quantum™ Front adapters

The front adapters mean that pre-assembled system cables can be directly connected to I/O modules. Two connection options are available:

- Transfer of max. 32 channels over one 50-position system cable
- Transmission of 4 x 8 channels over four 14-position system cables

Tailor-made VARIOFACE termination boards with a variety of functions and connection options round off this system concept.

Web code for the online configurator

 Your web code: #0007

Notes:
Controller-specific modules from page 474
Standard modules from page 526
For system cables, see page 550



Front adapter for Modicon® TSX Quantum™



Technical data

Maximum permissible operating voltage
Maximum permissible operating voltage UL / CSA

Maximum permissible current

Ambient temperature (operation)
Ambient temperature (storage/transport)
Mounting position
Standards/regulations

< 50 V AC / 60 V DC
125 V / -

1 A (per path)
4 A (per connection, supply via separate power supply)

-20 °C ... 50 °C
-20 °C ... 70 °C
any
IEC 60664 / DIN EN 50178

Ordering data

Description	No. of pos.
VARIOFACE front adapter , for Modicon® TSX Quantum™, 1 x 32 channels can be connected	50
VARIOFACE front adapter , for Modicon® TSX Quantum™, 4 x 8 channels can be connected	14

Type	Order No.	Pcs./ Pkt.
FLKM 50-PA-MODI-TSX/Q	2294306	1
FLKM 50/ 4-FLK14/PA-MODI-TSX/Q	2294416	1

Front adapters for I/O modules of the Modicon TSX Quantum™ automation devices

Card type	FLKM 50-PA-MODI-TSX/Q
Digital input	DDI 353 DDI 841* DDI 853 DAI 340* DAI 353** DAI 440* DAI 453**
Digital output	DDO 353
Digital input/output	DDM 390*
Analog input	ACI 030* ACI 040* ATI 030* ARI 030* AVI 030*
Analog output	ACO 020* ACO 130* AVO 020*
Analog input/output	AMM 090*
Counter	ECH 105* EHC 202*

* Only in conjunction with VIP-2/SC/FLK50/MODI-TSX/Q, Order No. 2322304.

** Only in conjunction with passive termination boards without LED.

Card type	FLKM 50/4-FLK14/PA-MODI-TSX/Q
Digital input	DDI 353 DDI 853 DAI 353** DAI 453**
Digital output	DDO 353

** Only in conjunction with passive termination boards without LED.

Explanation:

- IDC/FLK strip
- Connection to I/O card
- Screw terminal blocks for separate supply

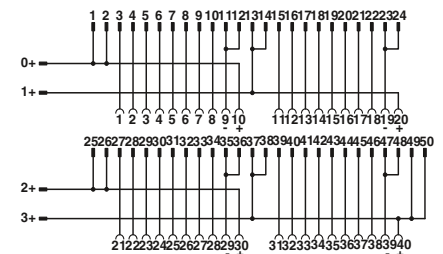

Connection scheme FLKM 50-PA-MODI-TSX/Q

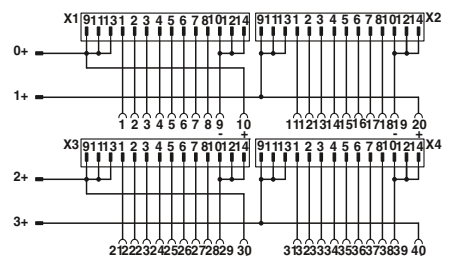

Connection scheme FLKM 50/ 4-FLK14/PA-MODI-TSX/Q

System cabling for controllers

Controller-specific system cabling

Schneider Electric Modicon M340 Front adapter

Pre-assembled system cables are connected directly to the 16-channel I/O modules using the front adapter. The adapters connect 2 x 8 channels of the controller via two 14-pos. system cables. Tailor-made VARIOFACE termination boards with a variety of functions and connection options are available for connection to field level. They round off this system concept.

Web code for the online configurator

i Your web code: #0007

Notes:
Standard modules from page 526
For system cables, see page 550



Schneider Electric Modicon M340 front adapter



Technical data

Maximum permissible operating voltage	< 50 V AC / 60 V DC
Maximum permissible operating voltage UL / CSA	50 V / 50 V
Maximum permissible current	1 A (per path)
Maximum permissible total current	3 A (per system cable when supplying from the module side) 10 A (When supplying via the front adapter)
Ambient temperature (operation)	-20 °C ... 60 °C
Ambient temperature (storage/transport)	-20 °C ... 60 °C
Mounting position	any
Standards/regulations	IEC 60664 / DIN EN 50178

Ordering data

Description	No. of pos.	Type	Order No.	Pcs./Pkt.
VARIOFACE front adapter , for Modicon® M340 with two FLK pin strips	14	FLKM 14-PA-MODI/M340	2903208	1

Front adapters for I/O modules of the Modicon C340 series

Card type	FLKM 14-PA-MODI/M340
Digital input	BMX DDI1602 BMX DDI1603 BMX DAI1602 BMX DAI1603
Digital output	BMX DDO1602 BMX DDO1612

Assignment table

Contacts, front adapter/controller	Connector (Byte 0)	Connector (Byte 1)
1	1	
2	2	
3	3	
4	4	
5	5	
6	6	
7	7	
8	8	
9		1
10		2
11		3
12		4
13		5
14		6
15		7
16		8
17	10, 12, 14 (-)	10, 12, 14 (-)
18	9, 11, 13 (+)	9, 11, 13 (+)
19	10, 12, 14 (-)	10, 12, 14 (-)
20	9, 11, 13 (+)	9, 11, 13 (+)

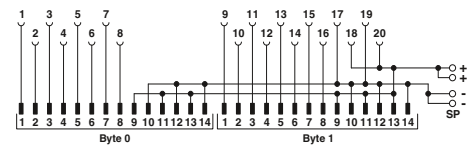

Connection scheme FLKM 14-PA-MODI/M340

Schneider Electric Modicon M340 System cable

These system cables are plugged onto the I/O cards that are connected using Fujitsu connectors.

CABLE-FCN40/1X50/...

– Signal transmission of 32 channels

CABLE-FCN40/4X14/...

– Splitting up 32 channels into 4 x 8 channels

Web code for the online configurator

i Your web code: **#0007**



Fujitsu FCN connector to IDC/FLK socket strip, number of positions: 40 to 50



Fujitsu FCN connector to IDC/FLK socket strip, number of positions: 40 to 4 x 14



Technical data

Maximum permissible operating voltage	< 50 V AC / 60 V DC
Maximum permissible operating voltage UL / CSA	125 V / -
Maximum permissible current carrying capacity per path	1 A
Maximum conductor resistance	0.16 Ω/m
Ambient temperature (operation)	-20 °C ... 50 °C
Conductor cross section	AWG 26 / 0.14 mm ²
Conductor structure: stranded wires / material	7 / Cu tin-plated



Technical data

Maximum permissible operating voltage	< 50 V AC / 60 V DC
Maximum permissible operating voltage UL / CSA	125 V / -
Maximum permissible current carrying capacity per path	1 A
Maximum conductor resistance	0.16 Ω/m
Ambient temperature (operation)	-20 °C ... 50 °C
Conductor cross section	AWG 26 / 0.14 mm ²
Conductor structure: stranded wires / material	7 / Cu tin-plated

Ordering data

Description	No. of pos.	Cable length	Type	Order No.	Pcs./ Pkt.
Round cable in variable lengths for BMX DDI 3202K, BMX DDI 6402K, BMX DD0 3202K, BMX DD0 6402K, BMX DDM 3202K					
	40	0.5 m	CABLE-FCN40/1X50/ 0,5M/M340	2321635	1
	40	1 m	CABLE-FCN40/1X50/ 1,0M/M340	2321648	1
	40	2 m	CABLE-FCN40/1X50/ 2,0M/M340	2321651	1
	40	3 m	CABLE-FCN40/1X50/ 3,0M/M340	2321664	1
	40	4 m	CABLE-FCN40/1X50/ 4,0M/M340	2321677	1
	40	6 m	CABLE-FCN40/1X50/ 6,0M/M340	2321680	1
	40	8 m	CABLE-FCN40/1X50/ 8,0M/M340	2321693	1
	40	10 m	CABLE-FCN40/1X50/10,0M/M340	2321703	1
	40	15 m	CABLE-FCN40/1X50/15,0M/M340	2903748	1

Ordering data

Type	Order No.	Pcs./ Pkt.
CABLE-FCN40/4X14/ 0,5M/M340	2321716	1
CABLE-FCN40/4X14/ 1,0M/M340	2321729	1
CABLE-FCN40/4X14/ 2,0M/M340	2321732	1
CABLE-FCN40/4X14/ 3,0M/M340	2321745	1
CABLE-FCN40/4X14/ 4,0M/M340	2321758	1
CABLE-FCN40/4X14/ 6,0M/M340	2321761	1
CABLE-FCN40/4X14/ 8,0M/M340	2321774	1
CABLE-FCN40/4X14/10,0M/M340	2321787	1
CABLE-FCN40/4X14/15,0M/M340	2903749	1

System cabling for controllers

Controller-specific system cabling

VIP – power cabling

Universal front adapters for Siemens SIMATIC® S7-300

Two versions are available:

- Connection of 40-pos. modules via four cables, each with a 10-pos. COMBI connector
- Connection of 20-pos. modules via two cables, each with a 10-pos. COMBI connector

The front adapters have the following features:

- Can be screwed on/snapped in with the I/O module
- Suitable for all common S7-300 modules, up to max. 250 V AC/DC, 6 A
- Universal 1:1 connection
- Numerically marked connectors

Combination example:

A front adapter with attached 10-pos. COMBI connectors is combined with the following terminal blocks for field connection:

Overall width of 52 mm per connector:

– 3045017 UT 2,5/1P

– 3210033 PT 2,5/1P

– 3040012 ST 2,5/1P

– 3040766 ST 2,5-TWIN-MT/1P

Reduced overall width of 35 mm per

connector:

– 3208582 PT 1,5/S/1P

– 3212439 PTTB 1,5/S/2P

You can find further versions, accessories, and combination options in Catalog 1 “Terminal blocks” in the “Plug-in COMBI connection solutions” section or online at phoenixcontact.net/products.

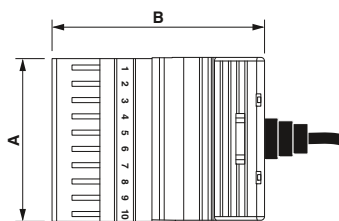

	A	B
...4X10COMBI...	52	70
...2X10COMBI...		
...4X10 PT...	35	62
...2X10 PT...		



Front adapter with punched-on connectors for 40 plug-in terminal blocks

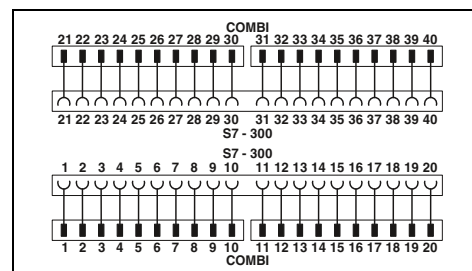

Technical data

Maximum permissible operating voltage
Maximum permissible operating voltage UL / CSA

Maximum permissible current

Maximum permissible total current

Maximum conductor resistance
Conductor cross section
Conductor structure: stranded wires / material
Outside diameter
Ambient temperature range
Standards/regulations
Connection method

Controller level
Field level

≤ 250 V AC/DC
250 V / 250 V

6 A (per single wire at 40°C)
4 A (per single wire at 60°C)
20 A (per cable at 40°C)
16 A (per cable at 60°C)

39 Ω/km
AWG 21 / 0.5 mm²
16 / Cu uninsulated
9 mm
-20 °C ... 60 °C
DIN EN 50178 , IEC 60664

Plug connection
COMBICON connectors

Ordering data

Description	Cable length
VIP - power cabling front adapter , for universal connection of the SIMATIC® S7-300, with an overall width of 52 mm per connector	
	0.5 m
	1 m
	1.5 m
	2 m
	2.5 m
	3 m
	4 m
	5 m
	6 m
	8 m
	10 m
VIP - power cabling front adapter , for universal connection of the SIMATIC® S7-300, with reduced overall width of 35 mm per connector	
	0.5 m
	1 m
	1.5 m
	2 m
	2.5 m
	3 m
	4 m
	5 m
	6 m
	8 m
	10 m

Type	Order No.	Pcs./ Pkt.
VIP-PA-PWR/4X10COMBI/ 0,5M/S7	2904702	1
VIP-PA-PWR/4X10COMBI/ 1,0M/S7	2904703	1
VIP-PA-PWR/4X10COMBI/ 1,5M/S7	2904704	1
VIP-PA-PWR/4X10COMBI/ 2,0M/S7	2904705	1
VIP-PA-PWR/4X10COMBI/ 2,5M/S7	2904706	1
VIP-PA-PWR/4X10COMBI/ 3,0M/S7	2904707	1
VIP-PA-PWR/4X10COMBI/ 4,0M/S7	2904708	1
VIP-PA-PWR/4X10COMBI/ 5,0M/S7	2904709	1
VIP-PA-PWR/4X10COMBI/ 6,0M/S7	2904710	1
VIP-PA-PWR/4X10COMBI/ 8,0M/S7	2904711	1
VIP-PA-PWR/4X10COMBI/10,0M/S7	2904712	1
VIP-PA-PWR/4X10 PT/ 0,5M/S7	2905516	1
VIP-PA-PWR/4X10 PT/ 1,0M/S7	2905517	1
VIP-PA-PWR/4X10 PT/ 1,5M/S7	2905518	1
VIP-PA-PWR/4X10 PT/ 2,0M/S7	2905519	1
VIP-PA-PWR/4X10 PT/ 2,5M/S7	2905520	1
VIP-PA-PWR/4X10 PT/ 3,0M/S7	2905521	1
VIP-PA-PWR/4X10 PT/ 4,0M/S7	2905522	1
VIP-PA-PWR/4X10 PT/ 5,0M/S7	2905523	1
VIP-PA-PWR/4X10 PT/ 6,0M/S7	2905524	1
VIP-PA-PWR/4X10 PT/ 8,0M/S7	2905525	1
VIP-PA-PWR/4X10 PT/10,0M/S7	2905526	1



Front adapter with punched-on connectors for 20 plug-in terminal blocks

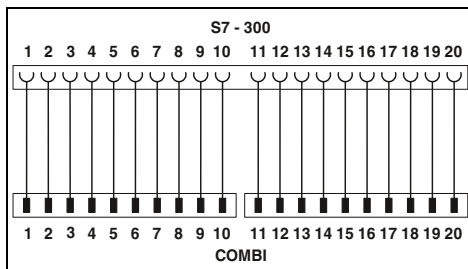

Technical data

≤ 250 V AC/DC
250 V / 250 V

6 A (per single wire at 40 °C)
4 A (per single wire at 60 °C)

20 A (per cable at 40 °C)
16 A (per cable at 60 °C)

39 Ω/km

AWG 21 / 0.5 mm²

16 / Cu uninsulated

9 mm

-20 °C ... 60 °C

DIN EN 50178 , IEC 60664

Plug connection

COMBICON connectors

Ordering data

Type	Order No.	Pcs./ Pkt.
VIP-PA-PWR/2X10COMBI/ 0,5M/S7	2904713	1
VIP-PA-PWR/2X10COMBI/ 1,0M/S7	2904714	1
VIP-PA-PWR/2X10COMBI/ 1,5M/S7	2904715	1
VIP-PA-PWR/2X10COMBI/ 2,0M/S7	2904716	1
VIP-PA-PWR/2X10COMBI/ 2,5M/S7	2904717	1
VIP-PA-PWR/2X10COMBI/ 3,0M/S7	2904718	1
VIP-PA-PWR/2X10COMBI/ 4,0M/S7	2904719	1
VIP-PA-PWR/2X10COMBI/ 5,0M/S7	2904720	1
VIP-PA-PWR/2X10COMBI/ 6,0M/S7	2904721	1
VIP-PA-PWR/2X10COMBI/ 8,0M/S7	2904722	1
VIP-PA-PWR/2X10COMBI/10,0M/S7	2904723	1
VIP-PA-PWR/2X10 PT/ 0,5M/S7	2905528	1
VIP-PA-PWR/2X10 PT/ 1,0M/S7	2905529	1
VIP-PA-PWR/2X10 PT/ 1,5M/S7	2905531	1
VIP-PA-PWR/2X10 PT/ 2,0M/S7	2905532	1
VIP-PA-PWR/2X10 PT/ 2,5M/S7	2905533	1
VIP-PA-PWR/2X10 PT/ 3,0M/S7	2905534	1
VIP-PA-PWR/2X10 PT/ 4,0M/S7	2905535	1
VIP-PA-PWR/2X10 PT/ 5,0M/S7	2905536	1
VIP-PA-PWR/2X10 PT/ 6,0M/S7	2905537	1
VIP-PA-PWR/2X10 PT/ 8,0M/S7	2905538	1
VIP-PA-PWR/2X10 PT/10,0M/S7	2905539	1

System cabling for controllers

Controller-specific system cabling

VIP – power cabling

Universal front adapters for Siemens SIMATIC® S7-300

Four versions are available:

- Connection of 40-pos. modules via 40 individual wires in rope structure (not assembled), PVC insulation
- Connection of 20-pos. modules via 20 individual wires in rope structure (not assembled), PVC insulation
- Connection of 40-pos. modules via 40 individual wires in rope structure (not assembled), insulation made from halogen-free material
- Connection of 20-pos. modules via 20 individual wires in rope structure (not assembled), insulation made from halogen-free material

The front adapters have the following features:

- Can be screwed on/snapped in with the I/O module
- Suitable for all common S7-300 modules, up to max. 250 V AC/DC, 6 A
- Universal 1:1 connection
- Numerically marked wires

Additional accessories, such as connection terminal blocks, can be found in Catalog 1 “Terminal blocks” or at phoenixcontact.net/products.



Front adapter with 40 open cable ends, PVC insulation

ERC

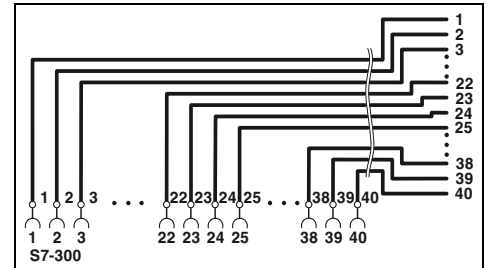

Technical data

Maximum permissible operating voltage	≤ 250 V AC/DC
Maximum permissible current	6 A (per single wire at 40°C) 4 A (per single wire at 60°C) 750 mA (per single wire at 75 °C)
Maximum permissible total current	20 A (per cable at 40 °C) 16 A (per cable at 60°C)
Maximum conductor resistance	39 Ω/km
Conductor cross section	AWG 21 / 0.5 mm ²
Conductor structure: stranded wires / material	16 / Cu uninsulated
Outside diameter	13 mm
Ambient temperature range	-20 °C ... 60 °C
Standards/regulations	DIN EN 50178 , IEC 60664
Connection method	Plug connection open cable end

Ordering data

Description	Cable length	Type	Order No.	Pcs./Pkt.
Front adapter with 40 open cable ends for connecting 40-pos. modules	1 m	VIP-PA-PWR/40XOE/ 1,0M/S7	2904731	1
	2 m	VIP-PA-PWR/40XOE/ 2,0M/S7	2904732	1
	3 m	VIP-PA-PWR/40XOE/ 3,0M/S7	2904733	1
	4 m	VIP-PA-PWR/40XOE/ 4,0M/S7	2904734	1
	6 m	VIP-PA-PWR/40XOE/ 6,0M/S7	2904735	1
	8 m	VIP-PA-PWR/40XOE/ 8,0M/S7	2904736	1
	10 m	VIP-PA-PWR/40XOE/10,0M/S7	2904737	1
Front adapter with 20 open cable ends for connecting 20-pos. modules	1 m			
	2 m			
	3 m			
	4 m			
	6 m			
	8 m			
	10 m			



Front adapter with 20 open cable ends,
PVC insulation



Front adapter with 40 open cable ends,
halogen-free



Front adapter with 20 open cable ends,
halogen-free

ERC



Technical data

≤ 250 V AC/DC
6 A (per single wire at 40°C)
4 A (per single wire at 60°C)
750 mA (per single wire at 75 °C)
20 A (per cable at 40 °C)
16 A (per cable at 60°C)
39 Ω/km
AWG 21 / 0.5 mm²
16 / Cu uninsulated
9 mm
-20 °C ... 60 °C
DIN EN 50178 , IEC 60664
Plug connection
open cable end

ERC

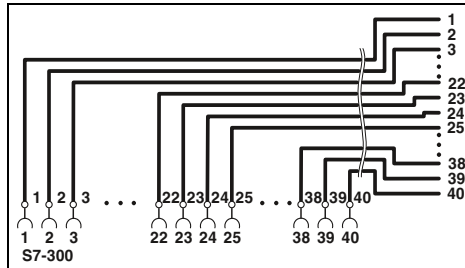

Technical data

≤ 250 V AC/DC
6 A (per single wire at 40°C)
4 A (per single wire at 60°C)
750 mA (per single wire at 75 °C)
20 A (per cable at 40 °C)
16 A (per cable at 60°C)
39 Ω/km
AWG 21 / 0.5 mm²
16 / Cu uninsulated
13 mm
-20 °C ... 60 °C
DIN EN 50178 , IEC 60664
Plug connection
open cable end

ERC

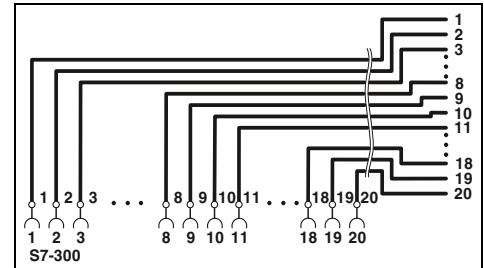

Technical data

≤ 250 V AC/DC
6 A (per single wire at 40°C)
4 A (per single wire at 60°C)
750 mA (per single wire at 75 °C)
20 A (per cable at 40 °C)
16 A (per cable at 60°C)
39 Ω/km
AWG 21 / 0.5 mm²
16 / Cu uninsulated
9 mm
-20 °C ... 60 °C
DIN EN 50178 , IEC 60664
Plug connection
open cable end

Ordering data

Type	Order No.	Pcs./ Pkt.
VIP-PA-PWR/20XOE/ 1,0M/S7	2904724	1
VIP-PA-PWR/20XOE/ 2,0M/S7	2904725	1
VIP-PA-PWR/20XOE/ 3,0M/S7	2904726	1
VIP-PA-PWR/20XOE/ 4,0M/S7	2904727	1
VIP-PA-PWR/20XOE/ 6,0M/S7	2904728	1
VIP-PA-PWR/20XOE/ 8,0M/S7	2904729	1
VIP-PA-PWR/20XOE/10,0M/S7	2904730	1

Ordering data

Type	Order No.	Pcs./ Pkt.
VIP-PA-PWR/40XOE/HF/ 1,0M/S7	2908909	1
VIP-PA-PWR/40XOE/HF/ 2,0M/S7	2908908	1
VIP-PA-PWR/40XOE/HF/ 3,0M/S7	2908907	1
VIP-PA-PWR/40XOE/HF/ 4,0M/S7	2908905	1
VIP-PA-PWR/40XOE/HF/ 6,0M/S7	2908904	1
VIP-PA-PWR/40XOE/HF/ 8,0M/S7	2908903	1
VIP-PA-PWR/40XOE/HF/10,0M/S7	2908902	1

Ordering data

Type	Order No.	Pcs./ Pkt.
VIP-PA-PWR/20XOE/HF/ 1,0M/S7	2908916	1
VIP-PA-PWR/20XOE/HF/ 2,0M/S7	2908915	1
VIP-PA-PWR/20XOE/HF/ 3,0M/S7	2908914	1
VIP-PA-PWR/20XOE/HF/ 4,0M/S7	2908913	1
VIP-PA-PWR/20XOE/HF/ 6,0M/S7	2908912	1
VIP-PA-PWR/20XOE/HF/ 8,0M/S7	2908911	1
VIP-PA-PWR/20XOE/HF/10,0M/S7	2908910	1

System cabling for controllers

Controller-specific system cabling

VIP – VARIOFACE Professional Front adapter for Siemens SIMATIC® S7-300

Three connection options are available:

- Transfer of max. 32 channels via two 50-pos. system cables (32-channel cards or this design)
- Transfer of 4 x 8 channels via two 14-pos. system cables (32-channel cards or this design)
- Transfer of 2 x 8 channels via two 14-pos. system cables (16-channel cards or this design)

The front adapters have the following features:

- Can be screwed with I/O module
- Voltage supply via terminal blocks with spring-cage double connection
- Encapsulated IDC/FLK socket strips for module side
Special lengths are configured using separate order numbers.

Ordering example:

A front adapter with a connected 50-pos. system cable (32-channel cards), 12.75 m in length:

1 pcs. 2900885/12,75

Web code for the online configurator

i Your web code: #0007

Notes:
The following modules cannot be coupled due to the larger outer contour of the molded connectors: UM 45-FLK14/ 8IM/ZFKDS/PLC, 2965211 UM 45-FLK50/32IM/ZFKDS/PLC, 2965224 UM 45- 8RM/MR-G24/1/PLC, 2962900 UM 45-16RM/MR-G24/1/PLC, 2962913
Controller-specific modules from page 508
Standard modules from page 526

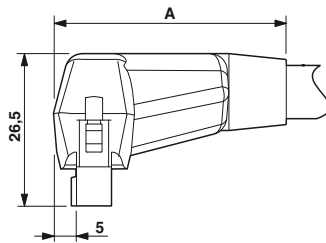

	A
...FLK14...	37
...FLK50...	42



Front adapter with system cable
1 x 32 channels can be connected

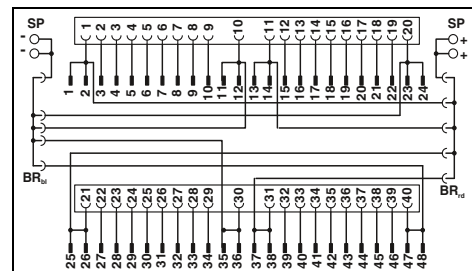

Technical data

Maximum permissible operating voltage
Maximum permissible operating voltage UL / CSA

< 50 V AC / 60 V DC
50 V / -

Maximum permissible current

1 A (per path)
8 A (Separate power supply)

Maximum conductor resistance
Conductor cross section
Conductor structure: stranded wires / material
Outside diameter

0.16 Ω/m
AWG 26 / 0.14 mm²
7 / Cu tin-plated
10.3 mm

Ambient temperature range
Standards/regulations
Connection method

-20 °C ... 50 °C
IEC 60664 , DIN EN 50178

Connection data solid/stranded/AWG

Control side
Field level

Plug connection
IDC/FLK socket strip
0.2 ... 2.5 mm² / 0.2 ... 2.5 mm² / 24 - 14

Ordering data

Description	Cable length	Type	Order No.	Pcs./ Pkt.
VIP VARIOFACE front adapter, with connected system cables for SIMATIC® S7-300				
	0.5 m	VIP-PA-FLK50/ 0,5M/S7	2322443	1
	1 m	VIP-PA-FLK50/ 1,0M/S7	2322456	1
	1.5 m	VIP-PA-FLK50/ 1,5M/S7	2322469	1
	2 m	VIP-PA-FLK50/ 2,0M/S7	2321800	1
	2.5 m	VIP-PA-FLK50/ 2,5M/S7	2322472	1
	3 m	VIP-PA-FLK50/ 3,0M/S7	2322485	1
	4 m	VIP-PA-FLK50/ 4,0M/S7	2322498	1
	5 m	VIP-PA-FLK50/ 5,0M/S7	2322508	1
	6 m	VIP-PA-FLK50/ 6,0M/S7	2322511	1
	7 m	VIP-PA-FLK50/ 7,0M/S7	2322524	1
	8 m	VIP-PA-FLK50/ 8,0M/S7	2322537	1
	10 m	VIP-PA-FLK50/10,0M/S7	2322540	1
VIP VARIOFACE front adapter, as above, in variable lengths				
		VIP-PA-FLK50-S7/...	2900885	1



Front adapter with system cable
4 x 8 channels can be connected



Front adapter with system cable
2 x 8 channels can be connected

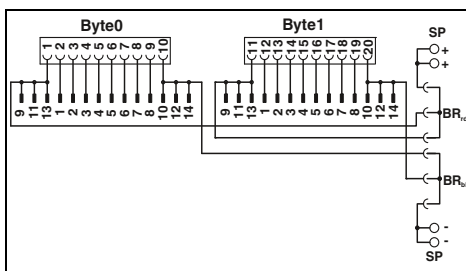
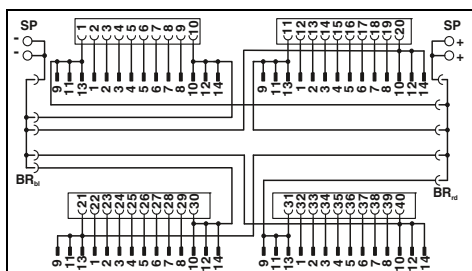

Technical data

< 50 V AC / 60 V DC
50 V / -

1 A (per path)
8 A (Separate power supply)
0.16 Ω/m
AWG 26 / 0.14 mm²
7 / Cu tin-plated
6.4 mm
-20 °C ... 50 °C
IEC 60664 , DIN EN 50178
Plug connection
IDC/FLK socket strip
0.2 ... 2.5 mm² / 0.2 ... 2.5 mm² / 24 - 14

Ordering data

Type	Order No.	Pcs./ Pkt.
VIP-PA-FLK50/4X14/ 0,5M/S7	2322553	1
VIP-PA-FLK50/4X14/ 1,0M/S7	2322566	1
VIP-PA-FLK50/4X14/ 1,5M/S7	2322579	1
VIP-PA-FLK50/4X14/ 2,0M/S7	2321910	1
VIP-PA-FLK50/4X14/ 2,5M/S7	2322582	1
VIP-PA-FLK50/4X14/ 3,0M/S7	2322595	1
VIP-PA-FLK50/4X14/ 4,0M/S7	2322605	1
VIP-PA-FLK50/4X14/ 5,0M/S7	2322618	1
VIP-PA-FLK50/4X14/ 6,0M/S7	2322621	1
VIP-PA-FLK50/4X14/ 7,0M/S7	2322634	1
VIP-PA-FLK50/4X14/ 8,0M/S7	2322647	1
VIP-PA-FLK50/4X14/10,0M/S7	2322650	1
VIP-PA-FLK50-4X14-S7/...	2900886	1

Technical data

< 50 V AC / 60 V DC
50 V / -

1 A (per path)
8 A (Separate power supply)
0.16 Ω/m
AWG 26 / 0.14 mm²
7 / Cu tin-plated
6.4 mm
-20 °C ... 50 °C
IEC 60664 , DIN EN 50178
Plug connection
IDC/FLK socket strip
0.2 ... 2.5 mm² / 0.2 ... 2.5 mm² / 24 - 14

Ordering data

Type	Order No.	Pcs./ Pkt.
VIP-PA-FLK14/ 0,5M/S7	2322663	1
VIP-PA-FLK14/ 1,0M/S7	2322676	1
VIP-PA-FLK14/ 1,5M/S7	2322689	1
VIP-PA-FLK14/ 2,0M/S7	2321790	1
VIP-PA-FLK14/ 2,5M/S7	2322692	1
VIP-PA-FLK14/ 3,0M/S7	2322702	1
VIP-PA-FLK14/ 4,0M/S7	2322715	1
VIP-PA-FLK14/ 5,0M/S7	2322728	1
VIP-PA-FLK14/ 6,0M/S7	2322731	1
VIP-PA-FLK14/ 7,0M/S7	2322744	1
VIP-PA-FLK14/ 8,0M/S7	2322757	1
VIP-PA-FLK14/10,0M/S7	2322760	1
VIP-PA-FLK14-S7/...	2900887	1

Front adapters for 32-channel cards of the SIMATIC® S7-300

Card type	VIP-PA-FLK50/...M/S7
Digital input	6ES7 321-1BL00-0AA0
Digital output	6ES7 322-1BL00-0AA0
Digital input/output	6ES7 323-1BL00-0AA0
Analog input	6ES7 331-7PF01-0AB0* 6ES7 331-7PF11-0AB0* 6ES7 331-7NF00-0AB0* 6ES7 331-7NF10-0AB0* 6ES7 331-1KF01-0AB0*
Analog output	6ES7 332-5HF00-0AB0*
CPU	312C, 313C, 314C, 313C-2PIP 313C-2DP, 314C-2DP
Other modules	6ES7 350-2AH01-0AE0* 6ES7 357-4AH01-0AE0*

Card type	VIP-PA-FLK50/4X14/...M/S7
Digital input	6ES7 321-1BL00-0AA0
Digital output	6ES7 322-1BL00-0AA0
Digital input/output	6ES7 323-1BL00-0AA0
CPU	313C, 314C, 313C-2PIP 313C-2DP, 314C-2DP

* Only in conjunction with
VIP-2/SC/FLK50 (1-40)/S7, Order No.: 2315243,
VIP-2/PT/FLK50 (1-40)/S7, Order No.: 2903804,
FLKM 50/KDS3-MT/PPA/S7-300, Order No.: 2304490.
All bridges (BR) on the adapter must be removed.

Front adapters for 16-channel cards of the SIMATIC® S7-300

Card type	VIP-PA-FLK14/...M/S7
Digital input	6ES7 321-1BH02-0AA0 6ES7 321-1BH10-0AA0 6ES7 321-1BH50-0AA0* 6ES7 321-7BH01-0AB0*
Digital output	6ES7 322-1BH01-0AA0 6ES7 322-1BH10-0AA0 6ES7 322-8BF00-0AB0*
Digital input/output	6ES7 323-1BH01-0AA0
Analog input	6ES7 331-7KF02-0AB0* 6ES7 331-7HF01-0AB0* 6ES7 331-7KB02-0AB0* 6ES7 331-7TF01-0AB0*
Analog output	6ES7 332-5HD01-0AB0* 6ES7 332-5HB01-0AB0* 6ES7 332-7ND02-0AB0*
Analog input/output	6ES7 334-0CE01-0AA0* 6ES7 334-0KE00-0AB0* 6ES7 335-7HG01-0AB0*
Other modules	6ES7 338-4BC01-0AB0* 6ES7 350-1AH03-0AE0* 6ES7 351-1AH01-0AE0* 6ES7 352-1AH02-0AE0* 6ES7 353-1AH01-0AE0* 6ES7 354-1AH01-0AE0* 6ES7 355-0VH10-0AE0* 6ES7 355-1VH10-0AE0*

* Only in conjunction with
VIP-2/SC/2FLK14 (1-20)/S7, Order No.: 2315230
VIP-2/PT/2FLK14 (1-20)/S7, Order No.: 2903802
FLKM-2FLK14/KDS 3-MT/PPA/S7, Order No.: 2295062
All bridges (BR) on the adapter must be disconnected.

Note:
The front adapters are non-isolated on delivery.
Electrical isolation can be achieved by removing the bridges (in groups of 8).

Explanation:
 IDC/FLK strip
 Connection to I/O card

SP: Separate power terminals
BR₊: Blue plug-in bridge
BR₋: Red plug-in bridge

System cabling for controllers

Controller-specific system cabling

Siemens SIMATIC® S7-300 Front adapter

I/O modules with 32 channels or with this design

- Two connection options are available:
 - Transfer of max. 32 channels over one 50-position system cable
 - Transmission of 4 x 8 channels over four 14-position system cables

Tailor-made VARIOFACE termination boards with a variety of functions and connection options round off this system concept.

Web code for the online configurator

i Your web code: **#0007**

Notes:
Controller-specific modules from page 508
Standard modules from page 526
For system cables, see page 550



Front adapter for SIMATIC® S7-300, I/O cards with max. 32 channels



Technical data

Maximum permissible operating voltage	< 50 V AC / 60 V DC
Maximum permissible operating voltage UL / CSA	125 V / -
Maximum permissible current	1 A (per path) 8 A (per connection, supply via separate power supply (2.8 x 0.8 mm))
Maximum permissible total current	2 A (per Byte, for supply via connector) 8 A (during supply via a separate bridged power supply)
Ambient temperature (operation)	-20 °C ... 50 °C
Ambient temperature (storage/transport)	-20 °C ... 70 °C
Standards/regulations	IEC 60664 / DIN EN 50178
Connection method	IDC/FLK pin strip

Front adapters for 32-channel cards of the SIMATIC® S7-300

Card type	FLKM 50-PA-S300
Digital input	6ES7 321-1BL00-0AA0
Digital output	6ES7 322-1BL00-0AA0
Digital input/output	6ES7 323-1BL00-0AA0
Analog input	6ES7 331-7PF01-0AB0* 6ES7 331-7PF11-0AB0* 6ES7 331-7NF00-0AB0* 6ES7 331-7NF10-0AB0* 6ES7 331-1KF01-0AB0*
Analog output	6ES7 332-5HF00-0AB0*
CPU	312C, 313C, 314C, 313C-2PiP 313C-2DP, 314C-2DP
Other modules	6ES7 350-2AH01-0AE0* 6ES7 357-4AH01-0AE0*

Card type	FLKM 50/4-FLK14/PA-S300
Digital input	6ES7 321-1BL00-0AA0
Digital output	6ES7 322-1BL00-0AA0
Digital input/output	6ES7 323-1BL00-0AA0
CPU	313C, 314C, 313C-2PiP 313C-2DP, 314C-2DP

* Only in conjunction with
VIP-2/SC/FLK50(1-40)/S7, Order No.: [2315243](#),
VIP-2/PT/FLK50(1-40)/S7, Order No.: [2903804](#),
FLKM 50/KDS3-MT/PPA/S7-300, Order No.: [2304490](#).
All wire bridges (DR) on the adapter must be disconnected.
There must be no voltage supply at the front adapter (flowing via the slip-on connections).

Note:
The front adapters are non-isolated on delivery.
Electrical isolation is achieved by removing the wire bridges (in groups of 8).

Explanation:
 IDC/FLK strip
 Connection to I/O card
 Screw terminal blocks for separate supply

Description	No. of pos.
VARIOFACE front adapters, for SIMATIC® S7-300	
- 1 x 32 channels can be connected	50
- 4 x 8 channels can be connected	14

Ordering data

Type	Order No.	Pcs./ Pkt.
FLKM 50-PA-S300	2294445	1
FLKM 50/4-FLK14/PA-S300	2296281	1

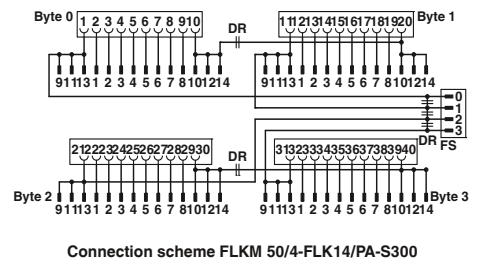
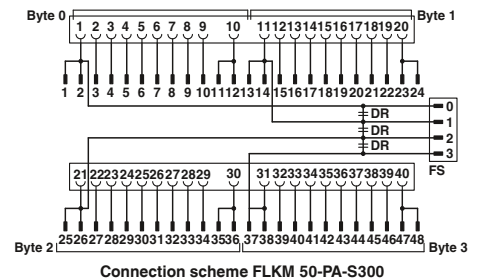

Siemens SIMATIC® S7-300

Front adapter

I/O modules with 16 channels or with this design

– Up to 2 x 8 channels are connected via two 14-position system cables.

Tailor-made VARIOFACE termination boards with a variety of functions and connection options round off this system concept.

Web code for the online configurator

 Your web code: **#0007**



Front adapter for SIMATIC® S7-300, I/O cards with max. 16 channels



Technical data

Maximum permissible operating voltage	< 50 V AC / 60 V DC
Maximum permissible operating voltage UL / CSA	125 V / -
Maximum permissible current	1 A (per path) 8 A (per connection, supply via separate power supply (2.8 x 0.8 mm))
Maximum permissible total current	2 A (per Byte, for supply via connector) 8 A (during supply via a separate bridged power supply)
Ambient temperature (operation)	-20 °C ... 50 °C
Ambient temperature (storage/transport)	-20 °C ... 70 °C
Standards/regulations	IEC 60664 / DIN EN 50178
Connection method	IDC/FLK pin strip

Front adapters for 16-channel cards of the SIMATIC® S7-300

Card type	FLKM 14-PA-S300
Digital input	6ES7 321-1BH02-0AA0 6ES7 321-1BH10-0AA0 6ES7 321-1BH50-0AA0* 6ES7 321-7BH01-0AB0*
Digital output	6ES7 322-1BH01-0AA0 6ES7 322-1BH10-0AA0 6ES7 322-8BF00-0AB0*
Digital input/output	6ES7 323-1BH01-0AA0
Analog input	6ES7 331-7KF02-0AB0* 6ES7 331-7HF01-0AB0* 6ES7 331-7KB02-0AB0* 6ES7 331-7TF01-0AB0*
Analog output	6ES7 332-5HD01-0AB0* 6ES7 332-5HB01-0AB0* 6ES7 332-7ND02-0AB0*
Analog input/output	6ES7 334-0CE01-0AA0* 6ES7 334-0KE00-0AB0* 6ES7 335-7HG01-0AB0*
Other modules	6ES7 338-4BC01-0AB0* 6ES7 350-1AH03-0AE0* 6ES7 351-1AH01-0AE0* 6ES7 352-1AH02-0AE0* 6ES7 353-1AH01-0AE0* 6ES7 354-1AH01-0AE0* 6ES7 355-0VH10-0AE0* 6ES7 355-1VH10-0AE0*



Description	No. of pos.
VARIOFACE front adapter, for SIMATIC® S7-300	
- 2 x 8 channels can be connected	14

Ordering data

Type	Order No.	Pcs./Pkt.
FLKM 14-PA-S300	2299770	1

* Only in conjunction with
VIP-2/SC/2FLK14 (1-20)/S7, Order No.: [2315230](#)
VIP-2/PT/2FLK14 (1-20)/S7, Order No.: [2903802](#)
FLKM-2FLK14/KDS 3-MT/PPA/S7, Order No.: [2295062](#)
All wire bridges (DR) on the adapter must be disconnected.
There must be no voltage supply at the front adapter (flowing via the slip-on connections).

Note:
The front adapters are non-isolated on delivery.
Electrical isolation is achieved by removing the wire bridges (in groups of 8).

Explanation:
 IDC/FLK strip
 Connection to I/O card
 Screw terminal blocks for separate supply

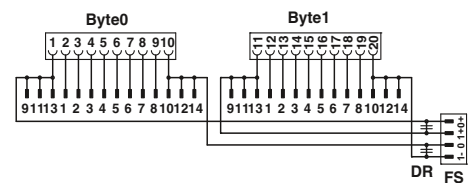

Connection scheme FLKM 14-PA-S300

Controller-specific system cabling

Siemens SIMATIC® S7-300 Front adapter for failsafe modules

The front adapters are coupled using 50-pos. system cables. They convert the signals for passive modules.

Notes:
Controller-specific modules from page 508
For system cables, see page 550



Front adapter for SIMATIC® S7-300
for failsafe I/O cards

Technical data

Maximum permissible operating voltage	< 50 V AC / 60 V DC
Maximum permissible current	1 A (per path)
Maximum permissible total current	2 A
Ambient temperature (operation)	-20 °C ... 50 °C
Ambient temperature (storage/transport)	-20 °C ... 70 °C
Standards/regulations	IEC 60664 / DIN EN 50178
Connection method	IDC/FLK pin strip

Ordering data

Description	No. of pos.	Type	Order No.	Pcs./Pkt.
VARIOFACE front adapter for failsafe I/O cards				
6ES7 326-1BK02-0AB0 6ES7 326-1RF00-0AB0 6ES7 336-1HE00-0AB0	50	FLKM 50-PA-S300/SO167	2307662	1
VARIOFACE front adapter for failsafe I/O cards				
6ES7 326-2BF01-0AB0	50	FLKM 50-PA/DO326/S7-300	2321952	1

Front adapters for I/O modules of the SIMATIC® S7-300

Card type	FLKM 50-PA-S300/SO167
Digital input	6ES7 326-1BK02-0AB0* 6ES7 326-1RF00-0AB0**
Analog input	6ES7 336-1HE00-0AB0*

Card type	FLKM 50-PA/DO326/S7-300
Digital output	6ES7 326-2BF01-0AB0** 6ES7 326-2BF10-0AB0**

* Only in conjunction with
VIP-2/SC/FLK50 (1-40)/S7, Order No.: [2315243](#),
VIP-2/PT/FLK50 (1-40)/S7, Order No.: [2903804](#),
FLKM 50/KDS3-MT/PPA/S7-300, Order No.: [2304490](#).

** Only in conjunction with
FLKM 50/DO326/S7-300, Order No.: [2321965](#).

1) Not suitable for signals from the Ex area.

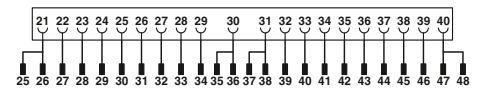
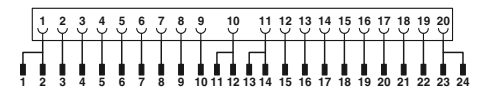

Connection scheme FLKM 50-PA-S300/SO167

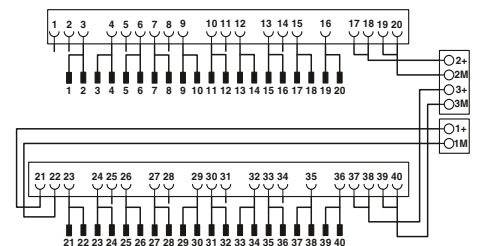

Connection scheme FLKM 50-PA/DO326/S7-300

Explanation:
 IDC/FLK strip
 Connection to I/O card
 Screw terminal blocks for separate supply

Siemens SIMATIC® S7-300
System cables for 64-channel I/O cards

These system cables are plugged onto the 64-channel (2x32) I/O cards that are directly connected using connectors.

CABLE-FCN40/1X50/...

- Signal transmission of 1x32 channels
- System cable: 40-pos. connector to 50-pos. IDC/FLK socket strip

CABLE-FCN40/4X14/...

- Signal transmission of 4x8 channels
- Splitting cable: 40-pos. connector to four 14-pos. IDC/FLK socket strips



System cable



Splitting cable



Technical data

Maximum permissible operating voltage	< 50 V AC / 60 V DC
Maximum permissible operating voltage UL / CSA	125 V / -
Maximum permissible current carrying capacity per path	1 A
Maximum conductor resistance	0.16 Ω/m
Ambient temperature (operation)	-20 °C ... 50 °C
Conductor cross section	AWG 26 / 0.14 mm ²
Conductor structure: stranded wires / material	7 / Cu tin-plated



Technical data

Maximum permissible operating voltage	< 50 V AC / 60 V DC
Maximum permissible operating voltage UL / CSA	125 V / -
Maximum permissible current carrying capacity per path	1 A
Maximum conductor resistance	0.16 Ω/m
Ambient temperature (operation)	-20 °C ... 50 °C
Conductor cross section	AWG 26 / 0.14 mm ²
Conductor structure: stranded wires / material	7 / Cu tin-plated

Ordering data

Description	No. of pos.	Cable length
Round cable, for output module 6ES7 322-1BP00-0AA0 and 6ES7 322-1BP50-0AA0 (two cables per module)		
	40	0.5 m
	40	1 m
	40	2 m
	40	3 m
	40	4 m
	40	6 m
	40	8 m
	40	10 m
Round cable, for input module 6ES7 321-1BP00-0AA0 (two cables per module). Plus-reading operation (sinking mode) of the module		
	40	0.5 m
	40	1 m
	40	2 m
	40	3 m
	40	4 m
	40	6 m
	40	8 m
	40	10 m

Type	Order No.	Pcs./ Pkt.
CABLE-FCN40/1X50/ 0,5M/S7-OUT	2321017	1
CABLE-FCN40/1X50/ 1,0M/S7-OUT	2321020	1
CABLE-FCN40/1X50/ 2,0M/S7-OUT	2321033	1
CABLE-FCN40/1X50/ 3,0M/S7-OUT	2321046	1
CABLE-FCN40/1X50/ 4,0M/S7-OUT	2321059	1
CABLE-FCN40/1X50/ 6,0M/S7-OUT	2321062	1
CABLE-FCN40/1X50/ 8,0M/S7-OUT	2321075	1
CABLE-FCN40/1X50/10,0M/S7-OUT	2321088	1
CABLE-FCN40/1X50/ 0,5M/S7-IN	2321091	1
CABLE-FCN40/1X50/ 1,0M/S7-IN	2321101	1
CABLE-FCN40/1X50/ 2,0M/S7-IN	2321114	1
CABLE-FCN40/1X50/ 3,0M/S7-IN	2321127	1
CABLE-FCN40/1X50/ 4,0M/S7-IN	2321130	1
CABLE-FCN40/1X50/ 6,0M/S7-IN	2321143	1
CABLE-FCN40/1X50/ 8,0M/S7-IN	2321156	1
CABLE-FCN40/1X50/10,0M/S7-IN	2321169	1

Ordering data

Type	Order No.	Pcs./ Pkt.
CABLE-FCN40/4X14/ 0,5M/S7-OUT	2321172	1
CABLE-FCN40/4X14/ 1,0M/S7-OUT	2321185	1
CABLE-FCN40/4X14/ 2,0M/S7-OUT	2321198	1
CABLE-FCN40/4X14/ 3,0M/S7-OUT	2321208	1
CABLE-FCN40/4X14/ 4,0M/S7-OUT	2321211	1
CABLE-FCN40/4X14/ 6,0M/S7-OUT	2321224	1
CABLE-FCN40/4X14/ 8,0M/S7-OUT	2321237	1
CABLE-FCN40/4X14/10,0M/S7-OUT	2321240	1
CABLE-FCN40/4X14/ 0,5M/S7-IN	2321253	1
CABLE-FCN40/4X14/ 1,0M/S7-IN	2321266	1
CABLE-FCN40/4X14/ 2,0M/S7-IN	2321279	1
CABLE-FCN40/4X14/ 3,0M/S7-IN	2321282	1
CABLE-FCN40/4X14/ 4,0M/S7-IN	2321295	1
CABLE-FCN40/4X14/ 6,0M/S7-IN	2321305	1
CABLE-FCN40/4X14/ 8,0M/S7-IN	2321318	1
CABLE-FCN40/4X14/10,0M/S7-IN	2321321	1

System cabling for controllers

Controller-specific system cabling

Siemens SIMATIC® S7-300 Front adapter for MINI Analog Pro

This front adapter is only for connecting the MINI MCR-2-V8-FLK16 adapter and corresponding MINI Analog Pro isolators. With the aid of these components, converted standard analog signals are transmitted.

Notes:
For corresponding isolators, see from page 68
For system cables (FLK16/EZ-DR/...), see page 588



Front adapter for SIMATIC® S7-300,
20-pos. analog I/O cards



Technical data

FLKM 16-PA-S300/MINI-MCR
< 50 V AC / 60 V DC
30 V / -
Maximum permissible operating voltage
Maximum permissible operating voltage UL / CSA
Maximum permissible current
50 mA (per path)
500 mA (per connection, supply via separate power supply)
Ambient temperature (operation)
Ambient temperature (storage/transport)
Standards/regulations
-20 °C ... 60 °C
-20 °C ... 70 °C
IEC 60664 / DIN EN 50178

Ordering data

Type	Order No.	Pcs./Pkt.
FLKM 16-PA-S300/MINI-MCR	2314749	1

Accessories

FLK 16/EZ-DR/ 300/KONFEK	2299330	1
MINI MCR-2-V8-FLK 16	2901993	1

Maximum permissible operating voltage
Maximum permissible operating voltage UL / CSA

Maximum permissible current

Ambient temperature (operation)
Ambient temperature (storage/transport)
Standards/regulations

Description	No. of pos.
VARIOFACE front adapter , for SIMATIC® S7-300, only in connection with MCR-2-V8-FLK16	16

Assembled round cable, with two 16-pos. IDC/FLK socket strips

System cabling adapter for MINI Analog Pro modules

Front adapters for analog cards of the SIMATIC® S7-300

Card type	FLKM 16-PA-S300/MINI-MCR
Analog input	6ES7 331-7KF02-0AB0 6ES7 331-7KB02-0AB0 6ES7 331-7KB81-0AB0 6ES7 331-7TF00-0AB0
Analog output	6ES7 332-8TF01-0AB0

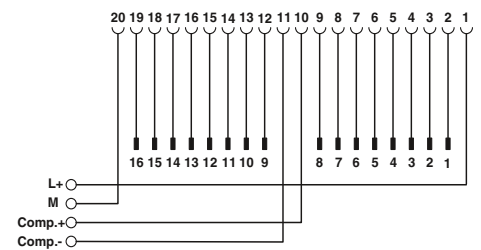

FLKM 16-PA-S300/MINI-MCR connection scheme

Explanation:

- IDC/FLK strip
- Connection to I/O card
- Screw terminal blocks for separate supply

Siemens SIMATIC® S7-300
Front adapter for
MINI Analog Pro system cabling

The **FLKM 16-PA-331-1KF//MINI-MCR** front adapter is used to implement system cabling in conjunction with the MINI Analog system adapter and a 16-pos. system cable.

Instead of the conventional front connector, screw terminal blocks are used to snap this component on to the analog module.

The DIP switches can be used to connect “M-” connections to each other and to the central ground of the system.

The front adapter supports **only current signals**.

The front adapter is suitable for the following analog input card:
 – 6ES7 331-1KF02-0AB0

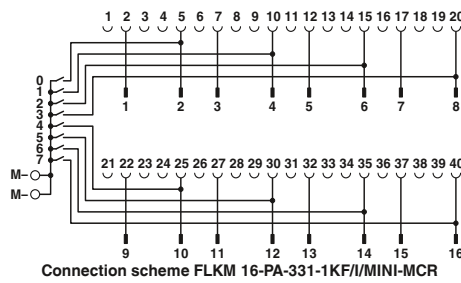

Connection scheme FLKM 16-PA-331-1KF//MINI-MCR

Maximum permissible operating voltage
 Maximum permissible operating voltage UL / CSA

Maximum permissible current
 Ambient temperature (operation)
 Ambient temperature (storage/transport)
 Standards/regulations

< 50 V AC / 60 V DC
 30 V / -
 50 mA (per path)
 -20 °C ... 60 °C
 -20 °C ... 70 °C
 IEC 60664 / DIN EN 50178



Front adapter for SIMATIC® S7-300,
 6ES7 331-1KF02-0AB0 analog I/O card

Technical data

Notes:
For corresponding isolators, see from page 68
For system cables (FLK16/EZ-DR/...), see page 588

Description	No. of pos.
VARIOFACE front adapter , for SIMATIC® S7-300, only in connection with MCR-2-V8-FLK16	16

Ordering data

Type	Order No.	Pcs./Pkt.
FLKM 16-PA- 331-1KF//MINI-MCR	2318237	1

Siemens SIMATIC® S7-300
Front adapter for
MINI Analog Pro system cabling

The **FLKM 16-PA-332-5HF//MINI-MCR** front adapter is used to implement system cabling in conjunction with the MINI Analog system adapter and a 16-pos. system cable.

Instead of the conventional front connector, screw terminal blocks are used to snap this component on to the analog module.

The front adapter supports **only current signals**.

The front adapter is suitable for the following analog output cards:
 – 6ES7 332-5HF00-0AB0

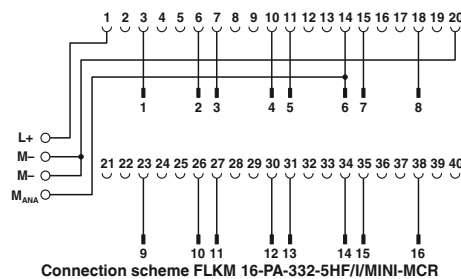

Connection scheme FLKM 16-PA-332-5HF//MINI-MCR

Maximum permissible operating voltage
 Maximum permissible operating voltage UL / CSA

Maximum permissible current
 Ambient temperature (operation)
 Ambient temperature (storage/transport)
 Standards/regulations

< 50 V AC / 60 V DC
 30 V / -
 50 mA (per path)
 500 mA (per connection, supply via separate power supply)
 -20 °C ... 60 °C
 -20 °C ... 70 °C
 IEC 60664 / DIN EN 50178



Front adapter for SIMATIC® S7-300,
 6ES7 332-5HF00-0AB0 analog I/O card

Technical data

Notes:
For corresponding isolators, see from page 68
For system cables (FLK16/EZ-DR/...), see page 588

Description	No. of pos.
VARIOFACE front adapter , for SIMATIC® S7-300, only in connection with MCR-2-V8-FLK16	16

Ordering data

Type	Order No.	Pcs./Pkt.
FLKM 16-PA- 332-5HF//MINI-MCR	2318240	1

System cabling for controllers

Controller-specific system cabling

VIP termination boards for Siemens SIMATIC® S7

These VIP - VARIOFACE Professional modules are used in combination with 50-pos. system cables and the relevant front adapters for S7.

Features:

- Numerical marking
- Specifically for S7-300 or S7-400

Notes:
For marking systems (e.g., "ZB 22:UNBEDRUCKT"; Order No. 0811862) and mounting material, see Catalog 3.
1) No CSA approval

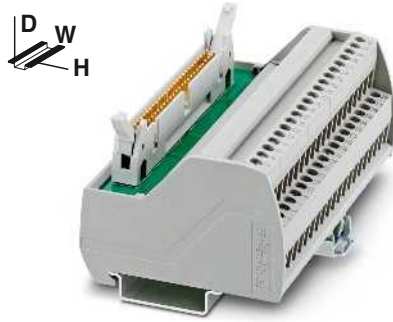

Passive termination boards for input/output, with SIMATIC®-specific marking and screw connection

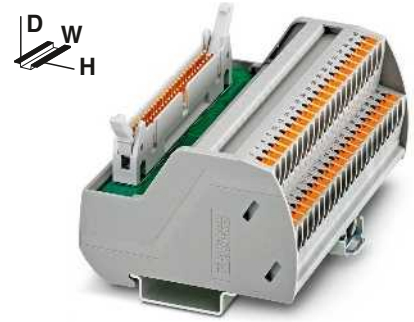

Passive termination boards for input/output, with SIMATIC®-specific marking and Push-in connection



Technical data

Maximum permissible operating voltage	60 V AC/DC
Maximum permissible operating voltage UL / CSA	125 V / 125 V
Maximum permissible current (per branch)	1 A
Ambient temperature (operation)	-20 °C ... 50 °C
Mounting position	any
Standards/regulations	IEC 60664 , DIN EN 50178
Connection method	Screw connection
	Field level
	Controller level
Connection data solid/stranded/AWG	IDC/FLK pin strip
Dimensions	0.2 ... 4 mm ² / 0.2 ... 2.5 mm ² / 24 - 12
	65.5 mm / 56 mm

Technical data

Maximum permissible operating voltage	60 V AC/DC
Maximum permissible operating voltage UL / CSA	125 V / 125 V
Maximum permissible current (per branch)	1 A
Ambient temperature (operation)	-20 °C ... 50 °C
Mounting position	any
Standards/regulations	IEC 60664 , DIN EN 50178
Connection method	Push-in connection
Connection data solid/stranded/AWG	IDC/FLK pin strip
Dimensions	0.14 ... 2.5 mm ² / 0.14 ... 2.5 mm ² / 26 - 14
	72.1 mm / 56 mm

Ordering data

Description	No. of pos.	Module width W
VARIOFACE termination board, with SIMATIC® S7-300-specific marking from 1 to 40		
- with screw connection	50	106.1 mm
- with Push-in connection	50	107.9 mm
VARIOFACE termination board, with SIMATIC® S7-400-specific marking from 3 to 48		
- with screw connection	50	106.1 mm
- with Push-in connection	50	107.9 mm

Type	Order No.	Pcs./ Pkt.
VIP-2/SC/FLK50 (1-40) /S7	2315243	1
VIP-2/SC/FLK50/S7/A-S400 ¹⁾	2322359	1

Ordering data

Type	Order No.	Pcs./ Pkt.
VIP-2/PT/FLK50 (1-40) /S7	2903804	1
VIP-2/PT/FLK50/S7/A-S400	2904289	1

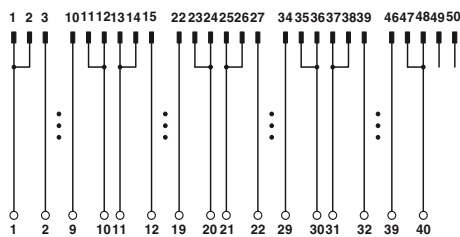

Connection scheme VIP-2/.../FLK50 (1-40) /S7

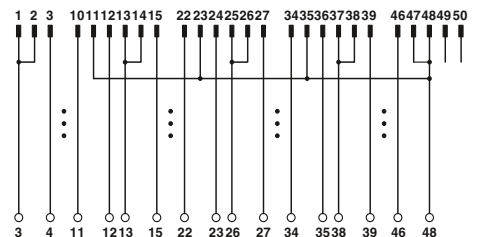

Connection scheme VIP-2/.../FLK50/S7/A-S400

VIP termination boards for Siemens SIMATIC® S7-300

These VIP - VARIOFACE Professional modules are used in combination with two 14-pos. system cables and the relevant front adapters for S7-300.

Features:

- Numerical marking (1-20)
- Specifically for S7-300

Notes:
For marking systems (e.g., "ZB 22:UNBEDRUCKT"; Order No. 0811862) and mounting material, see Catalog 3.

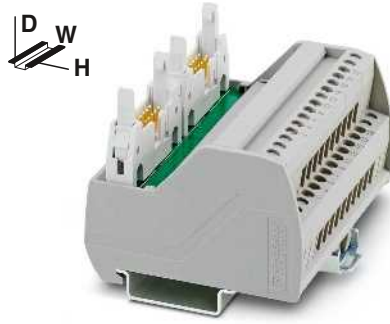

Passive termination boards for SIMATIC® S7-300 with screw connection

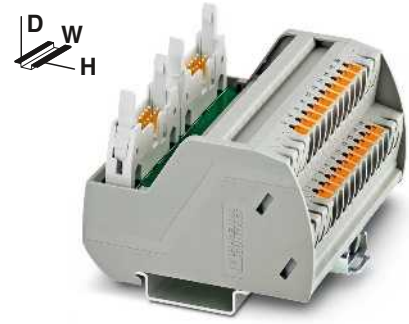

Passive termination boards for SIMATIC® S7-300 with Push-in connection



Technical data

Maximum permissible operating voltage	60 V AC/DC
Maximum permissible operating voltage UL / CSA	125 V / 125 V
Maximum permissible current (per branch)	1 A
Ambient temperature (operation)	-20 °C ... 50 °C
Mounting position	any
Standards/regulations	IEC 60664 , DIN EN 50178
Connection method	Screw connection
	Field level
	Controller level
Connection data solid/stranded/AWG	IDC/FLK pin strip
Dimensions	0.2 ... 4 mm ² / 0.2 ... 2.5 mm ² / 24 - 12 65.5 mm / 56 mm

Technical data

Maximum permissible operating voltage	60 V AC/DC
Maximum permissible operating voltage UL / CSA	125 V / 125 V
Maximum permissible current (per branch)	1 A
Ambient temperature (operation)	-20 °C ... 50 °C
Mounting position	any
Standards/regulations	IEC 60664 , DIN EN 50178
Connection method	Push-in connection
Connection data solid/stranded/AWG	IDC/FLK pin strip
Dimensions	0.14 ... 2.5 mm ² / 0.14 ... 2.5 mm ² / 26 - 14 72.1 mm / 56 mm

Ordering data

Description	No. of pos.	Module width W
VARIOFACE termination board, with SIMATIC® S7-300-specific marking from 1 to 20		
- with screw connection	14	80.6 mm
- with Push-in connection	14	82.5 mm

Type	Order No.	Pcs./ Pkt.
VIP-2/SC/2FLK14 (1-20) /S7	2315230	1

Ordering data

Type	Order No.	Pcs./ Pkt.
VIP-2/PT/2FLK14 (1-20) /S7	2903802	1

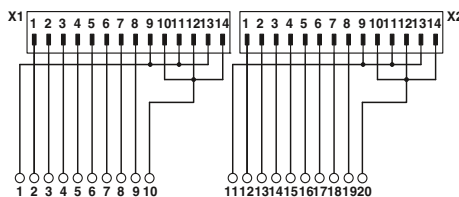

Connection diagram: VIP-2/.../2FLK14 (1-20) /S7

System cabling for controllers

Controller-specific system cabling

Siemens SIMATIC® S7-1500 Front adapter

Digital I/O modules with 32 channels

- Two connection options are available:
 - Transfer of max. 32 channels over one 50-position system cable
 - Transmission of 4 x 8 channels via a 14-position system cable

Digital I/O modules with 16 channels

- Transmission of 2 x 8 channels over two 14-position system cables
- Tailor-made VARIOFACE termination boards with a variety of functions and connection options round off this system concept.

Web code for the online configurator

i Your web code: **#0007**

Notes:
Standard modules from page 526
For system cables, see page 550

new



Front adapter for SIMATIC® S7-1500 digital I/O cards

ERC

Technical data

Maximum permissible operating voltage	< 50 V DC
Maximum permissible current	1 A (per path)
Maximum permissible total current	2 A (per byte when supplying from the module side) 12 A (When supplying via the front adapter)
Ambient temperature (operation)	-25 °C ... 60 °C
Ambient temperature (storage/transport)	-40 °C ... 70 °C
Standards/regulations	IEC 61131-2
Connection method	IDC/FLK pin strip

Ordering data

Type	Order No.	Pcs./Pkt.
FLKM 50-PA/SC/DIO/S7-1500	2907383	1
FLKM 50-PA/PT/DIO/S7-1500	2907384	1
FLKM 4X14-PA/SC/DIO/S7-1500	2907381	1
FLKM 4X14-PA/PT/DIO/S7-1500	2907382	1

Front adapters for 32-channel digital cards of the SIMATIC® S7-1500

Card type	FLKM 50-PA/.../DIO/S7-1500 FLKM 4X14-PA/.../DIO/S7-1500
Digital input	6ES7 521-1BL00-0AB0
Digital output	6ES7 522-1BL00-0AB0 6ES7 522-1BL01-0AB0

Description	No. of pos.
VARIOFACE front adapter , for SIMATIC® S7-1500 digital 35 mm modules, 1 x 32 channels can be connected	50
- with screw connection	50
- with Push-in connection	50
VARIOFACE front adapter , for SIMATIC® S7-1500 digital 35 mm modules, 4 x 8 or 2 x 8 channels can be connected	14
- with screw connection	14
- with Push-in connection	14

Front adapters for 16-channel digital cards of the SIMATIC® S7-1500

Card type	FLKM 4X14-PA/.../DIO/S7-1500
Digital input	6ES7 521-1BH00-0AB0 6ES7 521-1BH50-0AAA
Digital output	6ES7 522-1BH00-0AB0 6ES7 522-1BH01-0AB0

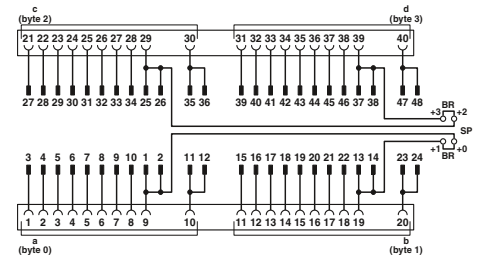

Connection scheme for FLKM 50-PA/.../DIO/S7-1500

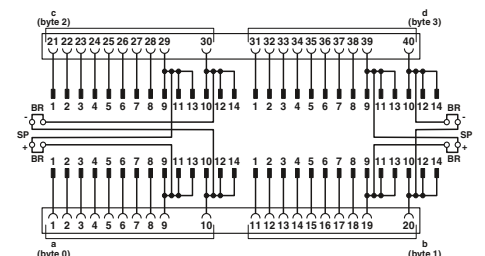

Connection scheme for FLKM 4X14-PA/.../DIO/S7-1500

Note:
The front adapters are non-isolated on delivery.
Electrical isolation is achieved by removing the wire bridges (in groups of 8).

Explanation:

 IDC/FLK strip
 Connection to I/O card
 Screw terminal blocks for separate supply

new

Siemens SIMATIC® S7-1500

Front adapter

Analog I/O modules with 8 channels

- Two connection options are available:
 - Transmission of a maximum of 8 channels via a 50-pos. system cable
 - Transmission of 4 x 2 channels via a 14-pos. system cable

Analog I/O modules with 4 channels

- Transmission of 2 x 2 channels via two 14-pos. system cables

Web code for the online configurator

i Your web code: **#0007**

Notes:

- Controller-specific modules from page 512
- For system cables, see page 550



Front adapter for SIMATIC® S7-1500 analog I/O cards

ERC

Technical data

Maximum permissible operating voltage	< 50 V DC
Maximum permissible current	1 A (per path)
Ambient temperature (operation)	-25 °C ... 60 °C
Ambient temperature (storage/transport)	-40 °C ... 70 °C
Standards/regulations	IEC 61131-2
Connection method	IDC/FLK pin strip

Ordering data

Description	No. of pos.	Type	Order No.	Pcs./Pkt.
VARIOFACE front adapter , for SIMATIC® S7-1500 analog 35 mm modules				
- 8 channels can be connected	50	FLKM 50-PA/AN/S7-1500	2907386	1
- 4 x 2 or 2 x 2 channels can be connected	14	FLKM 4X14-PA/AN/S7-1500	2907385	1

Front adapters for 8-channel analog cards of the SIMATIC® S7-1500 (only one 50-pos. cable is connected)

Card type	FLKM 50-PA/AN/S7-1500
Analog input	6ES7 531-7KF00-0AB0* 6ES7 531-7NF00-0AB0* 6ES7 531-7NF10-0AB0* 6ES7 531-7PF00-0AB0*
Analog output	6ES7 532-5HF00-0AB0*

Front adapters for 8-channel analog cards of the SIMATIC® S7-1500 (four 14-pos. cables are connected)

Card type	FLKM 4X14-PA/AN/S7-1500
Analog input	6ES7 531-7KF00-0AB0** 6ES7 531-7NF00-0AB0** 6ES7 531-7NF10-0AB0** 6ES7 531-7PF00-0AB0**
Analog output	6ES7 532-5HF00-0AB0**

Front adapters for 4-channel analog cards of the SIMATIC® S7-1500 (only two 14-pos. cables are connected)

Card type	FLKM 4X14-PA/AN/S7-1500
Analog output	6ES7 532-5HD00-0AB0*** 6ES7 532-5ND00-0AB0***

* Only in conjunction with
VIP-3/PT/FLK50/AN/S7-1500, Order No.: [2908496](#)
VIP-3/SC/FLK50/AN/S7-1500, Order No.: [2908495](#)
VIP-3/PT/FLK50/AN/2P/S7-1500, Order No.: [2908499](#)
VIP-3/SC/FLK50/AN/2P/S7-1500, Order No.: [2908497](#)
FLKM 50/KDS3-MT/PPA/S7-1500, Order No.: [2909893](#)

** Only in conjunction with
VIP-3/PT/2FLK14/AN/2P/S7-1500A, Order No.: [2908465](#)
VIP-3/SC/2FLK14/AN/2P/S7-1500A, Order No.: [2908464](#)
VIP-3/PT/2FLK14/AN/2P/S7-1500B, Order No.: [2908846](#)
VIP-3/SC/2FLK14/AN/2P/S7-1500B, Order No.: [2908845](#)
FLKM-2FLK14/KDS3-MT/AN/S7-1500, Order No.: [2909894](#)

*** Only in conjunction with
VIP-3/PT/2FLK14/AN/2P/S7-1500A, Order No.: [2908465](#)
VIP-3/SC/2FLK14/AN/2P/S7-1500A, Order No.: [2908464](#)
FLKM-2FLK14/KDS3-MT/AN/S7-1500, Order No.: [2909894](#)

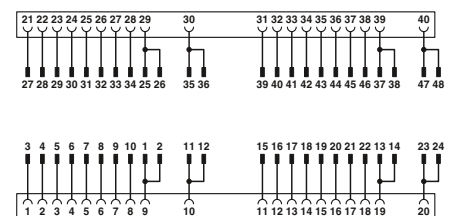

Connection diagram FLKM 50-PA/AN/S7-1500

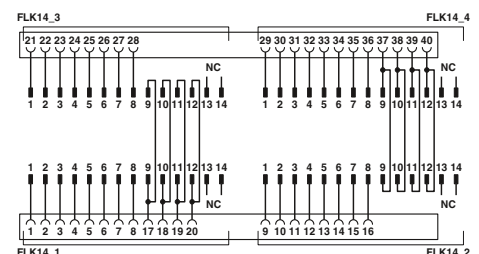

Connection diagram FLKM 4X14-PA/AN/S7-1500

System cabling for controllers

Controller-specific system cabling

VIP termination boards for analog I/O cards of Siemens SIMATIC® S7-1500

VARIOFACE termination board for Siemens S7-1500 systems with S7-1500-specific marking.

- One 50-pos. IDC/FLK pin strip
- Separate potentials L+ and M
- Printed channel marking

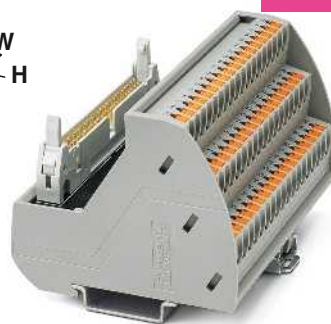

50-position IDC/FLK pin strip

new

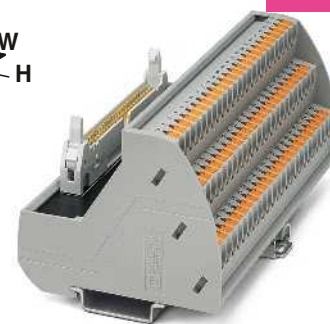

50-position IDC/FLK pin strip with potentials P1 and P2

new



Technical data

Maximum permissible operating voltage
60 V AC/DC
Maximum permissible operating voltage UL / CSA

Maximum permissible current (per branch)
7 A

Ambient temperature (operation)
Mounting position

Standards/regulations

Connection method

Field level
Controller level

Screw connection solid/stranded/AWG

Push-in connection solid/stranded/AWG

Dimensions

H / D

VIP-3/PT/FLK50/AN/S7-1500		VIP-3/SC/FLK50/AN/S7-1500	
Maximum permissible operating voltage	60 V AC/DC	Maximum permissible operating voltage	60 V AC/DC
Maximum permissible operating voltage UL / CSA	60 V / 60 V	Maximum permissible operating voltage UL / CSA	60 V / 60 V
Maximum permissible current (per branch)	1 A	Maximum permissible current (per branch)	1 A
Maximum total current (voltage supply)	7 A	Maximum total current (voltage supply)	7 A
Ambient temperature (operation)	-20 °C ... 60 °C	Ambient temperature (operation)	-20 °C ... 60 °C
Mounting position	any	Mounting position	any
Standards/regulations	IEC 60664, DIN EN 50178	Standards/regulations	IEC 60664, DIN EN 50178
Connection method	Push-in connection	Connection method	Screw connection
	IDC/FLK pin strip		IDC/FLK pin strip
Screw connection solid/stranded/AWG	0.2 ... 4 mm ² / 0.2 ... 2.5 mm ² / 24 - 12	Push-in connection solid/stranded/AWG	0.2 ... 4 mm ² / 0.2 ... 2.5 mm ² / 24 - 12
Push-in connection solid/stranded/AWG	0.14 ... 2.5 mm ² / 0.14 ... 2.5 mm ² / 26 - 14	Push-in connection solid/stranded/AWG	0.14 ... 2.5 mm ² / 0.14 ... 2.5 mm ² / 26 - 14
Dimensions	75.8 mm / 63 mm	Dimensions	68.8 mm / 60.7 mm

Technical data

Maximum permissible operating voltage
60 V AC/DC
Maximum permissible operating voltage UL / CSA

Maximum permissible current (per branch)
7 A

Ambient temperature (operation)
Mounting position

Standards/regulations

Connection method

Field level
Controller level

Screw connection solid/stranded/AWG

Push-in connection solid/stranded/AWG

Dimensions

H / D

VIP-3/PT/FLK50/AN/2P/S7-1500		VIP-3/SC/FLK50/AN/2P/S7-1500	
Maximum permissible operating voltage	60 V AC/DC	Maximum permissible operating voltage	60 V AC/DC
Maximum permissible operating voltage UL / CSA	60 V / 60 V	Maximum permissible operating voltage UL / CSA	60 V / 60 V
Maximum permissible current (per branch)	1 A	Maximum permissible current (per branch)	1 A
Maximum total current (voltage supply)	7 A	Maximum total current (voltage supply)	7 A
Ambient temperature (operation)	-20 °C ... 60 °C	Ambient temperature (operation)	-20 °C ... 60 °C
Mounting position	any	Mounting position	any
Standards/regulations	IEC 60664, DIN EN 50178	Standards/regulations	IEC 60664, DIN EN 50178
Connection method	Push-in connection	Connection method	Screw connection
	IDC/FLK pin strip		IDC/FLK pin strip
Screw connection solid/stranded/AWG	0.2 ... 4 mm ² / 0.2 ... 2.5 mm ² / 24 - 12	Push-in connection solid/stranded/AWG	0.2 ... 4 mm ² / 0.2 ... 2.5 mm ² / 24 - 12
Push-in connection solid/stranded/AWG	0.14 ... 2.5 mm ² / 0.14 ... 2.5 mm ² / 26 - 14	Push-in connection solid/stranded/AWG	0.14 ... 2.5 mm ² / 0.14 ... 2.5 mm ² / 26 - 14
Dimensions	75.8 mm / 63 mm	Dimensions	68.8 mm / 60.7 mm

Ordering data

Description	No. of pos.	Module width W
VARIOFACE termination board for Siemens S7-1500		
- with Push-in connection	50	97.7 mm
- with screw connection	50	97.7 mm
VARIOFACE termination board for Siemens S7-1500 marked 1 to 40, with potentials P1 and P2		
- with Push-in connection	50	128.2 mm
- with screw connection	50	128.2 mm

Type	Order No.	Pcs./ Pkt.
VIP-3/PT/FLK50/AN/S7-1500	2908496	1
VIP-3/SC/FLK50/AN/S7-1500	2908495	1

Ordering data

Type	Order No.	Pcs./ Pkt.
VIP-3/PT/FLK50/AN/2P/S7-1500	2908499	1
VIP-3/SC/FLK50/AN/2P/S7-1500	2908497	1

VIP termination boards for analog I/O cards of Siemens SIMATIC® S7-1500

VARIOFACE termination board for Siemens S7-1500 systems with S7-1500-specific marking.

- Two 14-pos. IDC/FLK pin strips
- Separate potentials L+, M, P1, and P2
- Printed channel marking

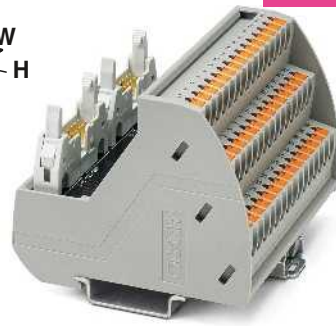

new

Two 14-position IDC/FLK pin strip marked 1 to 20

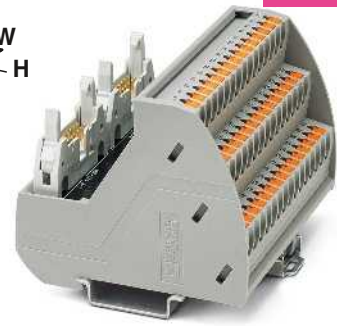

new

Two 14-position IDC/FLK pin strip marked 21 to 40



Technical data

Technical data

Maximum permissible operating voltage
Maximum permissible operating voltage UL / CSA

VIP-3/PT/2FLK14/AN/2P/S7-1500A	VIP-3/SC/2FLK14/AN/2P/S7-1500A
60 V AC/DC	60 V AC/DC
60 V / 60 V	60 V / 60 V

VIP-3/PT/2FLK14/AN/2P/S7-1500A	VIP-3/SC/2FLK14/AN/2P/S7-1500A
60 V AC/DC	60 V AC/DC
60 V / 60 V	60 V / 60 V

Maximum permissible current (per branch)
Maximum total current (voltage supply)

1 A	1 A
7 A	7 A

1 A	1 A
7 A	7 A

Ambient temperature (operation)
Mounting position

-20 °C ... 60 °C	-20 °C ... 60 °C
any	any

-20 °C ... 60 °C	-20 °C ... 60 °C
any	any

Standards/regulations

IEC 60664 , DIN EN 50178

IEC 60664 , DIN EN 50178

Connection method

Field level
Controller level

Push-in connection
IDC/FLK pin strip

Push-in connection
IDC/FLK pin strip

Screw connection solid/stranded/AWG

Push-in connection solid/stranded/AWG

Dimensions

H / D

0.2 ... 4 mm ² / 0.2 ... 2.5 mm ² / 24 - 12	Screw connection
0.14 ... 2.5 mm ² / 0.14 ... 2.5 mm ² / 26 - 14	IDC/FLK pin strip
75.8 mm / 63 mm	68.8 mm / 60.7 mm

0.2 ... 4 mm ² / 0.2 ... 2.5 mm ² / 24 - 12	Screw connection
0.14 ... 2.5 mm ² / 0.14 ... 2.5 mm ² / 26 - 14	IDC/FLK pin strip
75.8 mm / 63 mm	68.8 mm / 60.7 mm

Ordering data

Ordering data

Description	No. of pos.	Module width W
VARIOFACE termination board for Siemens S7-1500 marked 1 to 20		
- with Push-in connection	14	82.5 mm
- with screw connection	14	82.5 mm
VARIOFACE termination board for Siemens S7-1500 marked 21 to 40		
- with Push-in connection	14	82.5 mm
- with screw connection	14	82.5 mm

Type	Order No.	Pcs./ Pkt.
VIP-3/PT/2FLK14/AN/2P/S7-1500A	2908465	1
VIP-3/SC/2FLK14/AN/2P/S7-1500A	2908464	1

Type	Order No.	Pcs./ Pkt.
VIP-3/PT/2FLK14/AN/2P/S7-1500B	2908846	1
VIP-3/SC/2FLK14/AN/2P/S7-1500B	2908845	1

System cabling for controllers

Controller-specific system cabling

Siemens SIMATIC® S7-400 Front adapter

The front adapters mean that pre-assembled system cables can be directly connected to I/O modules.

FLKM 50-PA-S400

– Transmission of max. 32 digital channels over one 50-position system cable.

Web code for the online configurator

 Your web code: **#0007**

Notes:
Controller-specific modules page 508
Standard modules from page 526
For system cables, see page 550



Front adapter for SIMATIC® S7-400



Technical data

Maximum permissible operating voltage	< 50 V AC / 60 V DC
Maximum permissible operating voltage UL / CSA	125 V / -
Maximum permissible current	1 A (per path) 8 A (per connection, supply via separate power supply)
Maximum permissible total current	2 A (per Byte, for supply via connector) 8 A (during supply via a separate bridged power supply)
Ambient temperature (operation)	-20 °C ... 50 °C
Ambient temperature (storage/transport)	-20 °C ... 70 °C
Mounting position	any
Standards/regulations	IEC 60664 / DIN EN 50178

Front adapters for I/O modules of the SIMATIC® S7-400 Siemens automation devices

Card type	FLKM 50-PA-S400
Digital input	6ES7 421-1BL01-0AA0 6ES7 421-7BH01-0AB0* 6ES7 421-7DH00-0AB0*
Digital output	6ES7 422-1BL00-0AA0 6ES7 422-7BL00-0AB0

* Only in conjunction with
VIP-2/SC/FLK50/S7/A-S400, Order No.: [2322359](#)
VIP-2/PT/FLK50/S7/A-S400, Order No.: [2904289](#)
All DR wire bridges on the adapter must be disconnected.



Description	No. of pos.
VARIOFACE front adapter , for - SIMATIC® S7-400, 1 x 32 channels can be connected	50

Ordering data

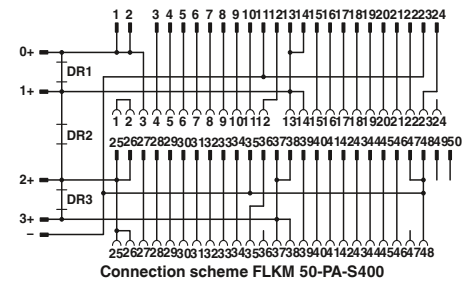
Type	Order No.	Pcs./ Pkt.
FLKM 50-PA-S400	2294500	2



Explanation:

-  IDC/FLK strip
-  Connection to I/O card
-  Screw terminal blocks for separate supply

Siemens SIMATIC® S7-400 Front adapter

The front adapters mean that pre-assembled system cables can be directly connected to I/O modules.

FLKM 50/4-FLK14/PA-S400

– Transmission of max. 32 digital channels via one 14-position system cable.

Tailor-made VARIOFACE termination boards with a variety of functions and connection options round off this system concept.

FLKM 50-PA-S400 (3-48)

– Analog channels are connected via a 50-position system cable.

The 1:1 connection of the adapter means that corresponding 1:1 termination boards are connected here.

Web code for the online configurator

i Your web code: #0007

Notes:
Controller-specific modules from page 567
Standard modules from page 526
For system cables, see page 550



Front adapter for SIMATIC® S7-400

ERIC

Technical data

FLKM 50/ 4-FLK14/PA-S400	FLKM 50-PA-S400(3-48)
< 50 V AC / 60 V DC	< 50 V AC / 60 V DC
1 A (per path)	1 A (per path)
8 A (per connection, supply via separate power supply)	

Maximum permissible operating voltage
Maximum permissible current

2 A (per Byte, for supply via connector) -

Maximum permissible total current

Ambient temperature (operation)
Ambient temperature (storage/transport)
Mounting position
Standards/regulations

-20 °C ... 50 °C
-20 °C ... 70 °C
any
IEC 60664 / DIN EN 50178
-20 °C ... 50 °C
-20 °C ... 70 °C
any
IEC 60664 / DIN EN 50178

Front adapters for I/O modules of the SIMATIC® S7-400 Siemens automation devices

Card type	FLKM 50/4-FLK14/PA-S400
Digital input	6ES7 421-1BL01-0AA0
Digital output	6ES7 422-1BL00-0AA0 6ES7 422-7BL00-0AB0

Card type	FLKM 50-PA-S400 (3-48)
Analog input	6ES7 431-0HH00-0AB0** 6ES7 431-1KF00-0AB0** 6ES7 431-1KF10-0AB0** 6ES7 431-1KF20-0AB0** 6ES7 431-7KF00-0AB0** 6ES7 431-7KF10-0AB0** 6ES7 431-7QH00-0AB0**
Analog output	6ES7 432-1HF00-0AB0**

** Only in conjunction with
VIP-3/SC/FLK50, Order No.: 2315081
VIP-3/PT/FLK50, Order No.: 2903794
FLKM 50/KDS 3-MT/PPA/AN/PLC, Order No.: 2291587

Description	No. of pos.
VARIOFACE front adapter, for - SIMATIC® S7-400, 4 x 8 channels can be connected	14
- SIMATIC® S7-400, only analog	50

Ordering data

Type	Order No.	Pcs./ Pkt.
FLKM 50/ 4-FLK14/PA-S400	2294429	2
FLKM 50-PA-S400(3-48)	2294908	2

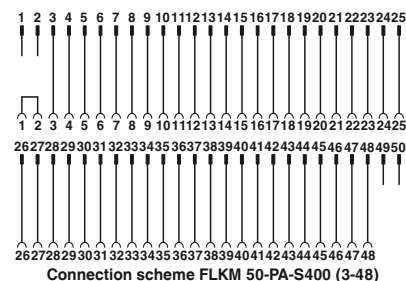
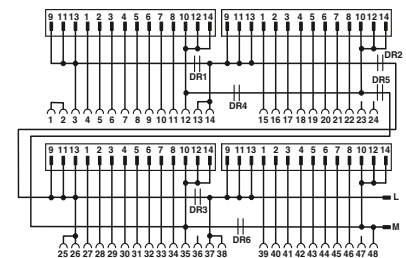

Explanation:
 IDC/FLK strip
 Connection to I/O card
 Screw terminal blocks for separate supply

System cabling for controllers

Controller-specific system cabling

Yokogawa CENTUM VP and ProSafe-RS Front adapter

These front adapters for digital (50-pos.) and analog (40-pos.) I/O modules are connected directly to the modules.

Features:

- Molded connector
- Can be screwed on
- Lateral cable outlet of the I/O module
- KS or AKB-compatible connectors on the module side



Shielded



Shielded and halogen-free



Technical data

Maximum permissible operating voltage	30 V DC
Maximum permissible operating voltage UL / CSA	125 V / -
Maximum permissible current carrying capacity per path	500 mA (per path at 70°C)
Maximum conductor resistance	0.16 Ω/m
Ambient temperature (operation)	-20 °C ... 70 °C
Conductor cross section	AWG 26 / 0.14 mm ²
Conductor structure: stranded wires / material	7 / Cu tin-plated
Outside diameter	11 mm
	40-pos. 9.8 mm



Technical data

Maximum permissible operating voltage	30 V DC
Maximum permissible operating voltage UL / CSA	125 V / -
Maximum permissible current carrying capacity per path	500 mA (per path at 70°C)
Maximum conductor resistance	0.16 Ω/m
Ambient temperature (operation)	-20 °C ... 70 °C
Conductor cross section	AWG 26 / 0.14 mm ²
Conductor structure: stranded wires / material	7 / Cu tin-plated
Outside diameter	11 mm
	9.8 mm

Ordering data

Description	No. of pos.	Cable length	Type	Order No.	Pcs./ Pkt.
Front adapter, for digital I/O modules					
	50	1 m	FLK 50-PA/EZ-DR/KS/ 100/YUC	2900991	1
	50	2 m	FLK 50-PA/EZ-DR/KS/ 200/YUC	2314299	1
	50	3 m	FLK 50-PA/EZ-DR/KS/ 300/YUC	2314309	1
	50	4 m	FLK 50-PA/EZ-DR/KS/ 400/YUC	2314312	1
	50	5 m	FLK 50-PA/EZ-DR/KS/ 500/YUC	2321499	1
	50	6 m	FLK 50-PA/EZ-DR/KS/ 600/YUC	2314927	1
	50	7 m	FLK 50-PA/EZ-DR/KS/ 700/YUC	2321509	1
	50	8 m	FLK 50-PA/EZ-DR/KS/ 800/YUC	2314930	1
	50	9 m	FLK 50-PA/EZ-DR/KS/ 900/YUC	2321512	1
	50	10 m	FLK 50-PA/EZ-DR/KS/1000/YUC	2314325	1
	50	15 m	FLK 50-PA/EZ-DR/KS/1500/YUC	2314338	1
	50	20 m	FLK 50-PA/EZ-DR/KS/2000/YUC	2314503	1
	50	25 m	FLK 50-PA/EZ-DR/KS/2500/YUC	2314516	1
	50	30 m	FLK 50-PA/EZ-DR/KS/3000/YUC	2314529	1
Front adapter, for analog I/O modules					
	40	1 m	FLK 40-PA/EZ-DR/KS/ 100/YUC	2322786	1
	40	2 m	FLK 40-PA/EZ-DR/KS/ 200/YUC	2314341	1
	40	3 m	FLK 40-PA/EZ-DR/KS/ 300/YUC	2314354	1
	40	4 m	FLK 40-PA/EZ-DR/KS/ 400/YUC	2314367	1
	40	5 m	FLK 40-PA/EZ-DR/KS/ 500/YUC	2321570	1
	40	6 m	FLK 40-PA/EZ-DR/KS/ 600/YUC	2314943	1
	40	7 m	FLK 40-PA/EZ-DR/KS/ 700/YUC	2321583	1
	40	8 m	FLK 40-PA/EZ-DR/KS/ 800/YUC	2314956	1
	40	9 m	FLK 40-PA/EZ-DR/KS/ 900/YUC	2321415	1
	40	10 m	FLK 40-PA/EZ-DR/KS/1000/YUC	2314370	1
	40	15 m	FLK 40-PA/EZ-DR/KS/1500/YUC	2314383	1
	40	20 m	FLK 40-PA/EZ-DR/KS/2000/YUC	2314532	1
	40	25 m	FLK 40-PA/EZ-DR/KS/2500/YUC	2314545	1
	40	30 m	FLK 40-PA/EZ-DR/KS/3000/YUC	2314558	1

Ordering data

Type	Order No.	Pcs./ Pkt.
FLK 50-PA/EZ-DR/HF/KS/ 100/YUC	2904739	1
FLK 50-PA/EZ-DR/HF/KS/ 200/YUC	2904740	1
FLK 50-PA/EZ-DR/HF/KS/ 300/YUC	2904741	1
FLK 50-PA/EZ-DR/HF/KS/ 400/YUC	2904742	1
FLK 50-PA/EZ-DR/HF/KS/ 500/YUC	2904636	1
FLK 50-PA/EZ-DR/HF/KS/ 600/YUC	2904743	1
FLK 50-PA/EZ-DR/HF/KS/ 700/YUC	2904744	1
FLK 50-PA/EZ-DR/HF/KS/ 800/YUC	2904745	1
FLK 50-PA/EZ-DR/HF/KS/ 900/YUC	2904746	1
FLK 50-PA/EZ-DR/HF/KS/1000/YUC	2904637	1
FLK 50-PA/EZ-DR/HF/KS/1500/YUC	2904638	1
FLK 50-PA/EZ-DR/HF/KS/2000/YUC	2904487	1
FLK 50-PA/EZ-DR/HF/KS/2500/YUC	2904639	1
FLK 50-PA/EZ-DR/HF/KS/3000/YUC	2904640	1
FLK 40-PA/EZ-DR/HF/KS/ 100/YUC	2904747	1
FLK 40-PA/EZ-DR/HF/KS/ 200/YUC	2904748	1
FLK 40-PA/EZ-DR/HF/KS/ 300/YUC	2904749	1
FLK 40-PA/EZ-DR/HF/KS/ 400/YUC	2904750	1
FLK 40-PA/EZ-DR/HF/KS/ 500/YUC	2904645	1
FLK 40-PA/EZ-DR/HF/KS/ 600/YUC	2904751	1
FLK 40-PA/EZ-DR/HF/KS/ 700/YUC	2904752	1
FLK 40-PA/EZ-DR/HF/KS/ 800/YUC	2904753	1
FLK 40-PA/EZ-DR/HF/KS/ 900/YUC	2904754	1
FLK 40-PA/EZ-DR/HF/KS/1000/YUC	2904646	1
FLK 40-PA/EZ-DR/HF/KS/1500/YUC	2904647	1
FLK 40-PA/EZ-DR/HF/KS/2000/YUC	2904488	1
FLK 40-PA/EZ-DR/HF/KS/2500/YUC	2904648	1
FLK 40-PA/EZ-DR/HF/KS/3000/YUC	2904649	1

Yokogawa CENTUM VP**Front adapter**

These front adapters for digital I/O modules are connected directly to the modules. Features:

- Lateral cable outlet of the I/O module
- Four 14-pos. connectors on the module side for connection of four 8-channel VARIOFACE modules of the system cabling

**Shielded**

Technical data	
Maximum permissible operating voltage	30 V DC
Maximum permissible current carrying capacity per path	500 mA (per path at 70°C)
Maximum conductor resistance	0.16 Ω/m
Ambient temperature (operation)	-20 °C ... 50 °C
Conductor cross section	AWG 26 / 0.14 mm ²
Outside diameter	11 mm

Ordering data					
Description	No. of pos.	Cable length	Type	Order No.	Pcs./ Pkt.
Front adapter for digital I/O modules for coupling four 8-channel VARIOFACE modules					
	50	2 m	CABLE-50/4FLK14/ 2,0M/YUC	2314655	1
	50	4 m	CABLE-50/4FLK14/ 4,0M/YUC	2314671	1
	50	6 m	CABLE-50/4FLK14/ 6,0M/YUC	2318978	1
	50	10 m	CABLE-50/4FLK14/10,0M/YUC	2314684	1
	50	15 m	CABLE-50/4FLK14/15,0M/YUC	2322773	1
	50	20 m	CABLE-50/4FLK14/20,0M/YUC	2314778	1

Yokogawa CENTUM VP**Front adapter for MINI Analog system cabling**

This front adapter enables 16 MINI Analog modules to be connected to a Yokogawa controller. Together with two MINI MCR-2-V8-FLK 16 MINI Analog system adapters, the Yokogawa system cable is a simple, cost-effective “Plug and Play” solution.

The front adapter is connected directly to the Yokogawa module. Two 16-pos. IDC/FLK socket strips are attached for connecting the module to the MINI Analog system adapters.

Together with **4-conductor measuring transducers**, the front adapter is suitable for the following analog cards:

- AAI 141
- AAI 143

**Shielded**

Technical data	
Maximum permissible operating voltage	30 V DC
Maximum permissible current carrying capacity per path	500 mA (per path at 70°C)
Maximum conductor resistance	0.16 Ω/m
Ambient temperature (operation)	-20 °C ... 50 °C
Conductor cross section	AWG 26 / 0.14 mm ²
Conductor structure: stranded wires / material	7 / Cu tin-plated
Outside diameter	11 mm

Ordering data					
Description	No. of pos.	Cable length	Type	Order No.	Pcs./ Pkt.
Front adapter , for analog I/O modules for coupling two 8-channel MINI analog system adapters					
	40	2 m	CABLE-40/2FLK16/ 2,0M/YUC	2321334	1
	40	4 m	CABLE-40/2FLK16/ 4,0M/YUC	2321347	1
	40	10 m	CABLE-40/2FLK16/10,0M/YUC	2321350	1
	40	15 m	CABLE-40/2FLK16/15,0M/YUC	2321376	1
	40	20 m	CABLE-40/2FLK16/20,0M/YUC	2321363	1

Controller-specific system cabling

Yokogawa CENTUM VP Termination boards

These modules are connected to the I/O module via the 50-pos. YUC system cable (on page 516).

The advantages:

- For digital modules
- Relay with integrated LED display per channel
- Flat-type plug-in fuse per channel
- Jumper option for field-side or module-side voltage supply
- Power supply via fuses with failure indicator

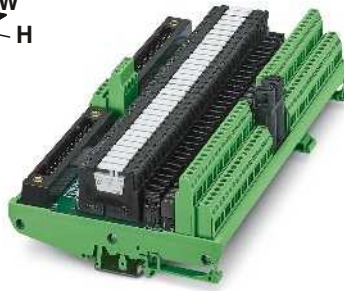

24 V DC relay output module

new

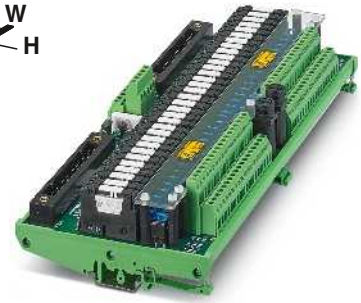

230 V AC relay output module

new

		Technical data			Technical data		
Coil side							
Operating voltage U_N		24 V DC		24 V DC			
Typical input current at U_N		7 mA		7 mA			
Typical response time at U_N		5 ms		5 ms			
Typical release time at U_N		6 ms		6 ms			
Input circuit		Freewheeling diode		Freewheeling diode			
Status indicator per channel		green LED		green LED			
Connection method		Screw connection		Screw connection			
Connection data solid/stranded/AWG		0.2 ... 4 mm ² / 0.2 ... 2.5 mm ² / 24 - 12		0.2 ... 4 mm ² / 0.2 ... 2.5 mm ² / 24 - 12			
Contact side							
Contact type		1 N/O contact		1 N/O contact			
Contact material		AgSnO		AgSnO			
Limiting continuous current		2 A (protected by fuse (2 AT))		2 A (protected by fuse (2 AT))			
Connection method		Yokogawa KS-compatible		Yokogawa KS-compatible			
No. of pos.		50		50			
General data							
Ambient temperature (operation)		-20 °C ... 50 °C		-20 °C ... 50 °C			
Nominal operating mode		100% operating factor		100% operating factor			
Mechanical service life		2 x 10 ⁷ cycles		2 x 10 ⁷ cycles			
Standards/regulations		DIN EN 50178 , IEC 60664-1		DIN EN 50178 , IEC 60664-1			
Mounting position		any		any			
Mounting		In rows with zero spacing		In rows with zero spacing			
Dimensions	H / D	128 mm / 55 mm		128 mm / 55 mm			
EMC note		Class A product, see page 605		Class A product, see page 605			
		Ordering data			Ordering data		
Description	Module width W	Type	Order No.	Pcs./ Pkt.	Type	Order No.	Pcs./ Pkt.
24 V DC relay module, for digital output modules ADV551, ADV561	218	UM-2KS50/32R/SI/J/DO24V/YCS	2908399	1			
230 V AC relay module, for digital output modules ADV551, ADV561	272				UM-2KS50/32R/SI/J/ADV551/YCS	2908400	1

Yokogawa CENTUM VP Termination boards

This module is connected to the I/O module via the 50-pos. YUC system cable (on page 516).

The advantages:

- Potential supply terminal blocks per channel
- Reduced overall width, thanks to miniature terminal blocks
- Flat-type plug-in fuse with failure indicator per channel
- Redundant voltage supply with integrated voltage monitoring and signal contact
- Status indicator for the redundant voltage supply



24 V DC input module

Technical data

Maximum permissible operating voltage	24 V DC
Maximum permissible current (per branch)	250 mA (protected by fuse (F 250mA))
Ambient temperature (operation)	-20 °C ... 50 °C
Mounting position	any
Standards/regulations	DIN EN 50178
Connection method	Screw connection
	Field level
	Controller level
Connection data solid/stranded/AWG	Yokogawa KS-compatible
Dimensions	0.2 ... 1.5 mm ² / 0.2 ... 1 mm ² / 26 - 16
	H / D
	128 mm / 61 mm

Ordering data

Description	No. of pos.	Module width W	Type	Order No.	Pcs./ Pkt.
24 V DC input module, for digital input modules ADV151, ADV161		135 mm	UM-2KS50/32IM/SI/BFI/YCS	2908402	1

System cabling for controllers

Controller-specific system cabling

Yokogawa CENTUM VP Termination boards

These modules are connected to the I/O module via the YUC system cable (on page 516).

FLKM-KS40/YCS:

- For analog modules
 - Universal termination board with 40 connecting terminal blocks
- Further system cabling solutions for Yokogawa at: phoenixcontact.com

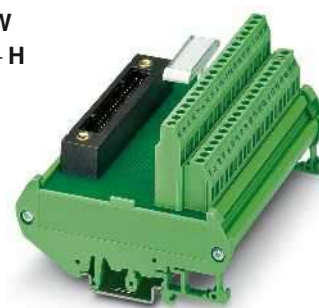

Passive termination boards

Technical data

Maximum permissible operating voltage	< 25 V AC / 30 V DC
Maximum permissible current (per branch)	1 A
Ambient temperature (operation)	-20 °C ... 50 °C
Mounting position	any
Standards/regulations	DIN EN 50178 , IEC 60664
Connection method	Screw connection
Field level	Yokogawa KS-compatible
Controller level	0.2 ... 4 mm ² / 0.2 ... 2.5 mm ² / 24 - 12
Connection data solid/stranded/AWG	90 mm / 68 mm
Dimensions	H / D

Ordering data

Description	No. of pos.	Module width W	Type	Order No.	Pcs./ Pkt.
Termination board , for analog I/O modules	40	112 mm	FLKM-KS40/YCS	2314642	1

Yokogawa CENTUM VP Termination boards

These modules are connected to the I/O module via the YUC system cable (on page 516).

FLKMS-KS50/32IM/YCS:

- For ADV151 and ADV551 digital modules
 - Three-conductor connection (signal, plus, minus)
 - Redundant voltage supply (fuse IEC 127-2, 5 x 20, 2 A)
- Further system cabling solutions for Yokogawa at: phoenixcontact.com

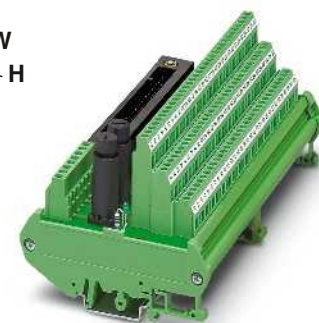

Passive termination boards

Technical data

Maximum permissible operating voltage	30 V DC
Maximum permissible current (per branch)	1 A
Ambient temperature (operation)	-20 °C ... 50 °C
Mounting position	any
Standards/regulations	DIN EN 50178 , IEC 60664
Connection method	Screw connection
Field level	Yokogawa KS-compatible
Controller level	0.2 ... 4 mm ² / 0.2 ... 2.5 mm ² / 24 - 12
Connection data solid/stranded/AWG	90 mm / 81 mm
Dimensions	H / D

Ordering data

Description	No. of pos.	Module width W	Type	Order No.	Pcs./ Pkt.
Termination board , for ADV151 and ADV551 digital I/O modules	50	174 mm	FLKMS-KS50/32IM/YCS	2314451	1

Yokogawa CENTUM VP Termination boards

These modules are connected to the analog I/O module via the 40-pos. YUC system cable (on page 516).

The modules are designed for redundant signal transmission (two connectors parallel). A separate connection to the HART multiplexer is possible.

FLKM-KS40/AO16/YCS

– For AAI543 analog module

FLKMS-KS40/SI/AI16/YCS

– For AAI141 and AAI143 analog modules (module operation in 4-conductor mode)

– Transfer of 16 channels with separate positive and negative connections

– 16 pluggable fuses (IEC 127-2, 5 x 20, 0.1 A) per positive supply and LED status indicator

– Redundant voltage supply (fuse IEC 127-2, 5 x 20, 2 A)

FLKMS-KS40/AI/YCS

– For AAI141 and AAI143 analog modules (module operation in 4-conductor mode)

– Transfer of 16 channels with separate positive and negative connections

– Redundant voltage supply (fuse IEC 127-2, 5 x 20, 2 A)

Further system cabling solutions for Yokogawa at: phoenixcontact.com



Termination boards for analog I/O modules

Technical data	
Maximum permissible operating voltage	30 V DC
Maximum permissible current (per branch)	100 mA
Ambient temperature (operation)	-20 °C ... 50 °C
Mounting position	any
Standards/regulations	DIN EN 50178 , IEC 60664
Connection method	Field level Screw connection
Connection data solid/stranded/AWG	Controller level Yokogawa KS-compatible
Dimensions	0.2 ... 4 mm ² / 0.2 ... 2.5 mm ² / 24 - 12 126 mm / 68 mm

Ordering data		
Description	No. of pos.	Module width W
Termination board , for AAI543 analog output modules	40	108 mm
Termination board , with fuses and LED, for AAI141 and AAI143 analog input modules	40	214 mm
Termination board , for AAI141 and AAI143 analog input modules, without fuses and LED	40	214 mm

Type	Order No.	Pcs./ Pkt.
FLKM-KS40/AO16/YCS	2314260	1
FLKMS-KS40/SI/AI16/YCS	2314273	1
FLKMS-KS40/AI/YCS	2314286	1

System cabling for controllers

Controller-specific system cabling

Yokogawa ProSafe-RS Termination boards

These modules are connected to the I/O module via the 50-pos. YUC system cable (on page 516).

- For SDV144 digital module
- Redundant signal transmission (two parallel connectors)
- 16 channels

UM-2KS50/16DI/RS/MKDS

- Screw connection
- Redundant voltage supply with signaling relay and fuse (IEC 127-2, 5 x 20, 3,15 AT)
- LED status display per channel

UM-2KS50/DI16/RS/K-MT/SO241

- Screw connection with knife disconnection
- Redundant voltage supply with signaling relay and fuse (TR5, 2 AT)
- Plug-in fuses (TR5, 0,1 AT) and LED status indicator per channel

Maximum permissible operating voltage	24 V DC ±5 %
Maximum permissible current (per branch)	100 mA
Ambient temperature (operation)	-20 °C ... 70 °C
Mounting position	any
Standards/regulations	DIN EN 50178
Connection method	Screw connection
	Field level
	Controller level
Connection data solid/stranded/AWG	0.2 ... 2.5 mm ² / 0.2 ... 1.5 mm ² / 24 - 14
Dimensions	112 mm / 80 mm



Passive termination boards

Technical data

Maximum permissible operating voltage	24 V DC ±5 %
Maximum permissible current (per branch)	100 mA
Ambient temperature (operation)	-20 °C ... 70 °C
Mounting position	any
Standards/regulations	DIN EN 50178
Connection method	Screw connection
	Field level
	Controller level
Connection data solid/stranded/AWG	0.2 ... 2.5 mm ² / 0.2 ... 1.5 mm ² / 24 - 14
Dimensions	112 mm / 80 mm

Ordering data

Description	No. of pos.	Module width W
Termination board, for I/O card: SDV144		
- with LED status indicator	50	162 mm
- with fuse and LED status indicator	50	181 mm

Type	Order No.	Pcs./ Pkt.
UM-2KS50/16DI/RS/MKDS	2900173	1
UM-2KS50/DI16/RS/K-MT/SO241	2319618	1

Yokogawa ProSafe-RS Termination boards

These modules are connected to the I/O module via the 40-pos. YUC system cable (on page 516).

- Redundant signal transmission (two parallel connectors)

UM-2KS40/16AI/SI/RS/SO225

- For SAI143 analog module
- Screw connection
- Redundant voltage supply with signaling relay and fuse (IEC 127-2, 5 x 20, 10 AT)
- Plug-in fuses (IEC 127-2, 5 x 20, 1 AT) and LED status indicator per channel

UM-2KS40/16AIO/RS/SO225

- For SAI143, SAV144, SAI533 analog modules
- Screw connection
- 16 analog inputs or 8 analog outputs

Maximum permissible operating voltage	30 V DC
Maximum permissible current (per branch)	1 A
Ambient temperature (operation)	-20 °C ... 55 °C
Mounting position	any
Standards/regulations	DIN EN 50178
Connection method	Screw connection
	Field level
	Controller level
Connection data solid/stranded/AWG	0.2 ... 4 mm ² / 0.2 ... 2.5 mm ² / 24 - 12
Dimensions	126 mm / 96 mm

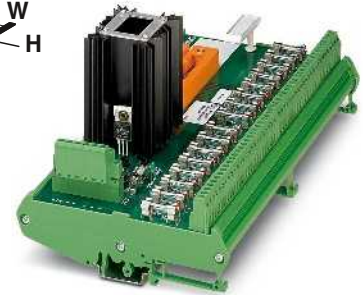

Passive termination boards

Technical data

Maximum permissible operating voltage	30 V DC
Maximum permissible current (per branch)	1 A
Ambient temperature (operation)	-20 °C ... 55 °C
Mounting position	any
Standards/regulations	DIN EN 50178
Connection method	Screw connection
	Field level
	Controller level
Connection data solid/stranded/AWG	0.2 ... 4 mm ² / 0.2 ... 2.5 mm ² / 24 - 12
Dimensions	126 mm / 96 mm

Ordering data

Description	No. of pos.	Module width W
Termination board, for I/O card: SAI143		
	50	250 mm
Termination board, for I/O card: SAI143, SAV144, and SAI533		
	50	168 mm

Type	Order No.	Pcs./ Pkt.
UM-2KS40/16AI/SI/RS/SO225	2319841	1
UM-2KS40/16AIO/RS/SO225	2319838	1

Yokogawa ProSafe-RS Termination boards

These modules are connected to the I/O module via the 50-pos. YUC system cable (on page 516).

UM-2KS50/8DO/RS/MKDS

- For SDV531 and SDV531L digital modules
- Redundant signal transmission (two parallel connectors)
- Screw terminal blocks
- Redundant voltage supply with signaling relay and fuse (IEC 127-2, 5 x 20, 3,15 AT)
- LED status display per channel

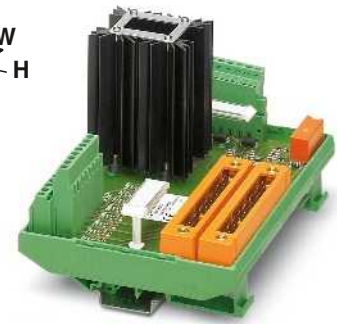

Passive termination boards

Technical data

Maximum permissible operating voltage	24 V DC ±5 %
Maximum permissible current (per branch)	100 mA
Ambient temperature (operation)	-20 °C ... 70 °C
Mounting position	any
Standards/regulations	DIN EN 50178
Connection method	Field level Screw connection
Connection data solid/stranded/AWG	Controller level Yokogawa KS-compatible
Dimensions	0.2 ... 2.5 mm ² / 0.2 ... 1.5 mm ² / 24 - 14 112 mm / 80 mm

Ordering data

Description	No. of pos.	Module width W	Type	Order No.	Pcs./Pkt.
Termination board , for I/O card: SDV531 and SDV531L					
	50	162 mm	UM-2KS50/ 8DO/RS/MKDS	2900174	1

Yokogawa ProSafe-RS Termination boards

These modules are connected to the I/O module via the 50-pos. YUC system cable (on page 516).

- Redundant signal transmission (two parallel connectors)
- Redundant voltage supply with signaling relay and fuse (IEC 127-2, 5 x 20, 6,3 AT)
- For SDV541 digital modules

UM-2KS50/DO16/RS/K-MT/SO241

- Screw connection with knife disconnection
- Plug-in fuses (TR5, 0,2 AT) and LED status indicator per channel

UM-2KS50/16DO/RS/MKDS

- Screw connection
- LED status display per channel

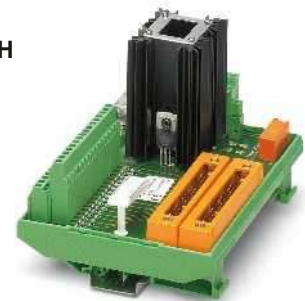

Passive termination boards

Technical data

Maximum permissible operating voltage	24 V DC ±5 %
Maximum permissible current (per branch)	100 mA
Ambient temperature (operation)	-20 °C ... 70 °C
Mounting position	any
Standards/regulations	DIN EN 50178
Connection method	Field level Screw connection
Connection data solid/stranded/AWG	Controller level Yokogawa KS-compatible
Dimensions	0.2 ... 2.5 mm ² / 0.2 ... 1.5 mm ² / 24 - 14 112 mm / 80 mm

Ordering data

Description	No. of pos.	Module width W	Type	Order No.	Pcs./Pkt.
Termination board , for I/O card: SDV541					
- with LED status indicator	50	162 mm	UM-2KS50/16DO/RS/MKDS	2900175	1
- with fuse and LED status indicator	50	215 mm	UM-2KS50/DO16/RS/K-MT/SO241	2319595	1

System cabling for controllers

Controller-specific system cabling

Termination Carriers for Yokogawa CENTUM VP and ProSafe-RS

The Termination Carriers are a compact solution for connecting signal conditioners and coupling relays to the Yokogawa CENTUM VP and ProSafe-RS systems.

- Mechanically decoupled PCB
- Redundant system connection
- Simple or redundant supply (diode decoupling, polarity reversal protection) and monitoring function. Implementation via separate DIN rail module or integrated switching on the PCB

Termination Carriers for MINI Analog signal conditioners

TC-2KS40-AI16-M-PRH-CS

- For AAI141/AAI143 analog I/O modules

TC-2KS40-AO16-M-PRH-CS

- For AAI543 analog I/O module

Termination Carriers for Ex i signal conditioners of the MACX Analog Ex series

TC-2KS50-DI32-2EX-PR-CS

- For ADV151/ADV161 digital I/O modules

TC-2KS50-DO32-EX-PR-CS

- For ADV551/ADV561 digital I/O modules

TC-2KS40-AO16-EX-PR-CS

- For AAI543 analog I/O module

TC-2KS40-AI16-EX-PR-CS

- For AAI141/AAI143 analog I/O modules

TC-2KS50-DO16-EX-PR-RS

- For SDV541 digital I/O module

TC-2KS50-DI16-EX-PR-RS

- For SDV144 digital I/O modules

TC-2KS40-AI16-EX-PR-RS

- For SAI143 analog I/O module

TC-2KS40-AO8-EX-PR-RS

- For SAI533 analog I/O module

Termination Carriers for coupling relays from the PSR-ETP or PSR-FSP series

TC-2KS50-DO16-F&G-AR-RS

- For SDV541 digital I/O modules

TC-2KS50-DO16-ESD-AR-RS

- For SDV541 digital I/O modules



Termination Carrier for Centum VP system, can be used with signal conditioners of the MINI Analog series



General data	
Connection to the control system level	Yokogawa KS-compatible
Maximum operating voltage	< 30 V DC (Per signal/channel)
Maximum permissible current	23 mA (Signal/channel)
Degree of pollution/surge voltage category	2 / II
Air clearances and creepage distances	DIN EN 50178 (Basic insulation)
Ambient temperature range	-20 °C ... 60 °C (Please observe module specifications)
Shock	15g, according to IEC 60068-2-27
Vibration (operation)	2g, according to IEC 60068-2-6
Dimensions H / D	170 / 160 mm
EMC note	
Power supply via power module	
Input voltage range	19.2 V DC ... 30 V DC
Redundant supply	yes, decoupled from diodes
Polarization and surge protection	Yes
Fuse	2x 2.5 A on PCB, slow-blow (replaceable)
Status indication	2 x red LED (error) 2x green LEDs (PWR1 and PWR2) 1 N/C contact (alarm = open)

Technical data		
Yokogawa KS-compatible		
< 30 V DC (Per signal/channel)		
23 mA (Signal/channel)		
2 / II		
DIN EN 50178 (Basic insulation)		
-20 °C ... 60 °C (Please observe module specifications)		
15g, according to IEC 60068-2-27		
2g, according to IEC 60068-2-6		
170 / 160 mm		
19.2 V DC ... 30 V DC		
yes, decoupled from diodes		
Yes		
2x 2.5 A on PCB, slow-blow (replaceable)		
2 x red LED (error)		
2x green LEDs (PWR1 and PWR2)		
1 N/C contact (alarm = open)		

Switching output	
Description	Module width W
Termination Carrier for 16 highly compact signal conditioners	
- For AAI141 and AAI143 analog I/O modules	148 mm
- For AAI543 analog I/O modules	148 mm
Termination Carrier for 16/32 Ex i signal conditioners (SIL 2)	
- For ADV151 and ADV161 digital I/O modules	242 mm
- For ADV551 and ADV561 digital I/O modules	448 mm
- For AAI543 analog I/O module	242 mm
- For AAI141 and AAI143 analog I/O modules	242 mm
Termination Carrier for 8/16 Ex i signal conditioners (SIL 2)	
- For SDV144 digital I/O modules	242 mm
- For SDV541 digital I/O modules	242 mm
- For SAI143 analog I/O module	242 mm
- For SAI533 analog I/O module	148 mm
Termination Carrier for 16 PSR-FSP/PSR-ETP relays	
- For SDV541 digital I/O modules (low-demand application)	304 mm
- For SDV541 digital I/O module (high-demand application)	304 mm

Ordering data		
Type	Order No.	Pcs./ Pkt.
TC-2KS40-AI16-M-PRH-CS	2905257	1
TC-2KS40-AO16-M-PRH-CS	2905905	1

MINI Analog power terminal	MINI MCR-SL-PTB-FM	2902958	1
MINI Analog fault signaling module	MINI MCR-SL-FM-RC-NC	2902961	1
Power and fault signaling module			
Cable set with 24 V module supply, suitable for PSR-ETP/Order No.: 2986711			
Cable set without use of confirmation contact, suitable for PSR-FSP/Order No.: 2981978			
Cable set with use of confirmation contact, suitable for PSR-FSP/Order No.: 2986960 and 2986575			
Jumper plug for occupying unused module slots, suitable for PSR-FSP/Order No.: 2986960 and 2986575			

Accessories		
MINI MCR-SL-PTB-FM	2902958	1
MINI MCR-SL-FM-RC-NC	2902961	1



Termination Carrier for Centum VP System, can be used with Ex i signal conditioners of the MACX Analog Ex series



Termination Carrier for ProSafe-RS system, can be used with Ex i signal conditioners of the MACX Analog Ex series



Termination Carrier for ProSafe-RS system, can be used with coupling relays from the PSR-ETP or PSR-FSP series

Technical data
Yokogawa KS-compatible
< 30 V DC (Per signal/channel)
1 A (Signal/channel)
2 / II
DIN EN 50178 (Basic insulation)
-20 °C ... 60 °C (Please observe module specifications)
15g, according to IEC 60068-2-27
2g, according to IEC 60068-2-6
170 / 160 mm
19.2 V DC ... 30 V DC
yes, decoupled from diodes
Yes
2x 2.5 A on PCB, slow-blow (replaceable)
1 x red LED (error)
2x green LEDs (PWR1 and PWR2)
1 N/C contact (alarm = open)

Technical data
Yokogawa KS-compatible
< 30 V DC (Per signal/channel)
1 A (Signal/channel)
2 / II
DIN EN 50178 (Basic insulation)
-20 °C ... 60 °C (Please observe module specifications)
15g, according to IEC 60068-2-27
2g, according to IEC 60068-2-6
170 / 160 mm
19.2 V DC ... 30 V DC
yes, decoupled from diodes
Yes
2x 2.5 A on PCB, slow-blow (replaceable)
1 x red LED (error)
2x green LEDs (PWR1 and PWR2)
1 N/C contact (alarm = open)

Technical data
Yokogawa KS-compatible
24 V DC (21.1 V ... 26.4 V)
1 A (Per signal/channel)
2 / II
DIN EN 50178 (Basic insulation)
-20 °C ... 60 °C
15g, according to IEC 60068-2-27
2g, according to IEC 60068-2-6
170 / 160 mm
Class A product, see page 605
21.1 V DC ... 26.4 V DC
yes, decoupled from diodes
Yes
2.5 A on PCB, slow-blow (replaceable)
2 x red LED (error)
2x green LEDs (PWR1 and PWR2)
1 N/C contact (alarm = open)

Ordering data		
Type	Order No.	Pcs./ Pkt.
TC-2KS50-DI32-2EX-PR-CS	2904676	1
TC-2KS50-DO32-EX-PR-CS	2905199	1
TC-2KS40-AO16-EX-PR-CS	2905201	1
TC-2KS40-AI16-EX-PR-CS	2905677	1
TC-2KS50-DI16-EX-PR-RS	2905202	1
TC-2KS50-DO16-EX-PR-RS	2905678	1
TC-2KS40-AI16-EX-PR-RS	2905203	1
TC-2KS40-AO8-EX-PR-RS	2905204	1
TC-2KS50-DO16-F&G-AR-RS	2904112	1
TC-2KS50-DO16-ESD-AR-RS	2904113	1

Ordering data		
Type	Order No.	Pcs./ Pkt.
TC-2KS50-DI32-2EX-PR-CS	2904676	1
TC-2KS50-DO32-EX-PR-CS	2905199	1
TC-2KS40-AO16-EX-PR-CS	2905201	1
TC-2KS40-AI16-EX-PR-CS	2905677	1
TC-2KS50-DI16-EX-PR-RS	2905202	1
TC-2KS50-DO16-EX-PR-RS	2905678	1
TC-2KS40-AI16-EX-PR-RS	2905203	1
TC-2KS40-AO8-EX-PR-RS	2905204	1
TC-2KS50-DO16-F&G-AR-RS	2904112	1
TC-2KS50-DO16-ESD-AR-RS	2904113	1

Ordering data		
Type	Order No.	Pcs./ Pkt.
TC-2KS50-DI32-2EX-PR-CS	2904676	1
TC-2KS50-DO32-EX-PR-CS	2905199	1
TC-2KS40-AO16-EX-PR-CS	2905201	1
TC-2KS40-AI16-EX-PR-CS	2905677	1
TC-2KS50-DI16-EX-PR-RS	2905202	1
TC-2KS50-DO16-EX-PR-RS	2905678	1
TC-2KS40-AI16-EX-PR-RS	2905203	1
TC-2KS40-AO8-EX-PR-RS	2905204	1
TC-2KS50-DO16-F&G-AR-RS	2904112	1
TC-2KS50-DO16-ESD-AR-RS	2904113	1

Accessories		
Type	Order No.	Pcs./ Pkt.
TC-MACX-MCR-PTB	2904673	1

Accessories		
Type	Order No.	Pcs./ Pkt.
TC-MACX-MCR-PTB	2904673	1

Accessories		
Type	Order No.	Pcs./ Pkt.
TC-C-PSR3-SC-A100V+A20000	2903391	16
TC-C-PSR3-SC-A10000A20000	2903389	16
TC-C-PSR3-SC-A10000A23132	2903390	16
TC-C-PTSM-50-00000000J1J1	2903388	8

System cabling for controllers

Controller-specific system cabling

VIP termination boards for 8 channels

These VIP - VARIOFACE Professional modules are used in combination with 14-pos. system cables and the relevant front adapters.

Features:

- Byte-wise marking
- For digital I/O modules
- With LED as an option

Notes:
For marking systems (e.g., "ZB 22:UNBEDRUCKT"; Order No. 0811862) and mounting material, see Catalog 3.



Passive termination boards for input/output with screw connection



Passive termination boards for input/output with Push-in connection



Technical data	
VIP-2/.../FLK14/PLC	VIP-2/.../FLK14/LED/PLC
Maximum permissible operating voltage 60 V AC/DC	24 V DC
Maximum permissible operating voltage UL / CSA 125 V / 125 V	24 V / 24 V
Maximum permissible current (per branch) 1 A	1 A
Maximum total current (voltage supply) 3 A	3 A
Ambient temperature (operation) -20 °C ... 50 °C	-20 °C ... 50 °C
Mounting position any	any
Standards/regulations IEC 60664 , DIN EN 50178	
Connection method Screw connection	Screw connection
Field level IDC/FLK pin strip	IDC/FLK pin strip
Controller level IDC/FLK pin strip	IDC/FLK pin strip
Connection data solid/stranded/AWG 0.2 ... 4 mm ² / 0.2 ... 2.5 mm ² / 24 - 12	
Dimensions 65.5 mm / 56 mm	

Ordering data		
Type	Order No.	Pcs./ Pkt.
VIP-2/SC/FLK14/PLC	2315214	1
VIP-2/SC/FLK14/LED/PLC	2322249	1



Technical data	
VIP-2/.../FLK14/PLC	VIP-2/.../FLK14/LED/PLC
Maximum permissible operating voltage 60 V AC/DC	24 V DC
Maximum permissible operating voltage UL / CSA 125 V / 125 V	24 V / 24 V
Maximum permissible current (per branch) 1 A	1 A
Maximum total current (voltage supply) 3 A	3 A
Ambient temperature (operation) -20 °C ... 50 °C	-20 °C ... 50 °C
Mounting position any	any
Standards/regulations IEC 60664 , DIN EN 50178	
Connection method Push-in connection	Push-in connection
Field level IDC/FLK pin strip	IDC/FLK pin strip
Controller level IDC/FLK pin strip	IDC/FLK pin strip
Connection data solid/stranded/AWG 0.14 ... 2.5 mm ² / 0.14 ... 2.5 mm ² / 26 - 14	
Dimensions 72.1 mm / 56 mm	

Ordering data		
Type	Order No.	Pcs./ Pkt.
VIP-2/PT/FLK14/PLC	2903801	1
VIP-2/PT/FLK14/LED/PLC	2904279	1

Description	No. of pos.	Module width W
VARIOFACE termination board , for eight channels,		
- with screw connection	14	39.8 mm
- with Push-in connection	14	41.9 mm
VARIOFACE termination board , for eight channels with light indicator,		
- with screw connection	14	39.8 mm
- with Push-in connection	14	41.9 mm

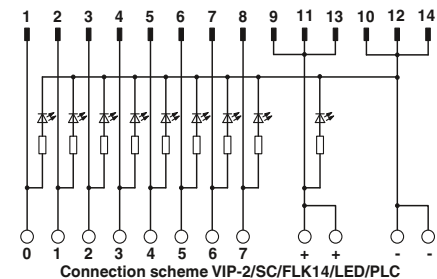
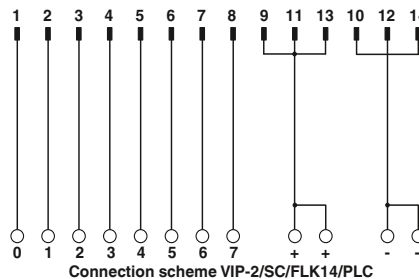

VIP termination boards for 32 channels

These VIP - VARIOFACE Professional modules are used in combination with 50-pos. system cables and the relevant front adapters.

Features:

- Byte-wise marking
- For digital I/O modules
- With LED as an option

Notes:
For marking systems (e.g., "ZB 22:UNBEDRUCKT"; Order No. 0811862) and mounting material, see Catalog 3.

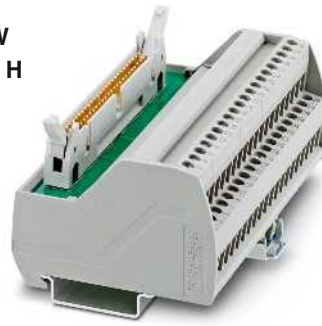

Passive termination boards for input/output with screw connection

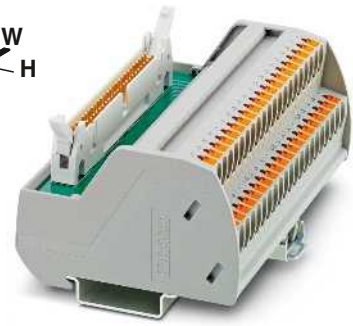

Passive termination boards for input/output with Push-in connection



Technical data	
VIP-2/.../FLK50/PLC	VIP-2/.../FLK50/LED/PLC
60 V AC/DC	24 V DC
125 V / 125 V	24 V / 24 V
1 A	1 A
2 A (per byte)	2 A (per byte)
-20 °C ... 50 °C	-20 °C ... 50 °C
any	any
IEC 60664 , DIN EN 50178	
Screw connection	Screw connection
IDC/FLK pin strip	IDC/FLK pin strip
0.2 ... 4 mm ² / 0.2 ... 2.5 mm ² / 24 - 12	
Dimensions	H / D
	65.5 mm / 56 mm

Ordering data		
Type	Order No.	Pcs./ Pkt.
VIP-2/SC/FLK50/PLC	2315227	1
VIP-2/SC/FLK50/LED/PLC	2322252	1



Technical data	
VIP-2/.../FLK50/PLC	VIP-2/.../FLK50/LED/PLC
60 V AC/DC	24 V DC
125 V / 125 V	24 V / 24 V
1 A	1 A
2 A (per byte)	2 A (per byte)
-20 °C ... 50 °C	-20 °C ... 50 °C
any	any
IEC 60664 , DIN EN 50178	
Push-in connection	Push-in connection
IDC/FLK pin strip	IDC/FLK pin strip
0.14 ... 2.5 mm ² / 0.14 ... 2.5 mm ² / 26 - 14	
Dimensions	H / D
	72.1 mm / 56 mm

Ordering data		
Type	Order No.	Pcs./ Pkt.
VIP-2/PT/FLK50/PLC	2903803	1
VIP-2/PT/FLK50/LED/PLC	2904280	1

Maximum permissible operating voltage	
Maximum permissible operating voltage UL / CSA	
Maximum permissible current (per branch)	
Maximum total current (voltage supply)	
Ambient temperature (operation)	
Mounting position	
Standards/regulations	
Connection method	Field level
	Controller level
Connection data solid/stranded/AWG	
Dimensions	H / D

Description	No. of pos.	Module width W
VARIOFACE termination board, for 32 channels,		
- with screw connection	50	106.1 mm
- with Push-in connection	50	107.9 mm
VARIOFACE termination board, for 32 channels with light indicator,		
- with screw connection	50	106.1 mm
- with Push-in connection	50	107.9 mm

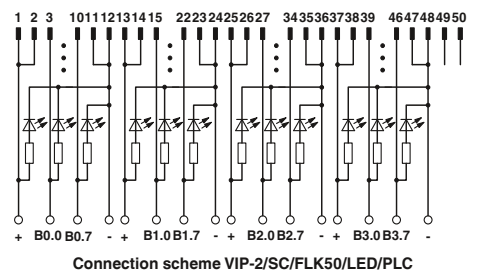
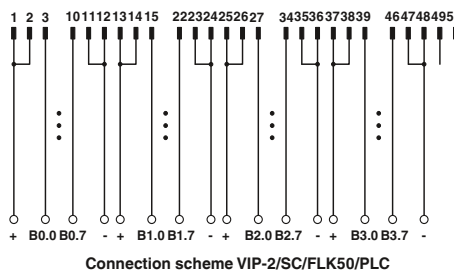

System cabling for controllers

Controller-specific system cabling

VIP termination boards in 2-conductor connection technology for 8 channels

These VIP - VARIOFACE Professional modules are used in combination with 14-pos. system cables and the relevant front adapters.

Features:

- Byte-wise marking
- For digital I/O modules
- Negative or positive connection per signal.

Notes:
For marking systems (e.g., "ZB 22:UNBEDRUCKT"; Order No. 0811862) and mounting material, see Catalog 3.



Passive termination boards with screw connection



Passive termination boards with Push-in connection



Technical data	
Maximum permissible operating voltage	60 V DC
Maximum permissible operating voltage UL / CSA	125 V / -
Maximum permissible current (per branch)	1 A
Maximum total current (voltage supply)	3 A (per byte)
Ambient temperature (operation)	-20 °C ... 50 °C
Mounting position	any
Standards/regulations	IEC 60664 , DIN EN 50178
Connection method	Screw connection
	Field level
	Controller level
Connection data solid/stranded/AWG	0.2 ... 4 mm ² / 0.2 ... 2.5 mm ² / 24 - 12
Dimensions	65.5 mm / 56 mm

Technical data		
Maximum permissible operating voltage	60 V AC/DC	
Maximum permissible operating voltage UL / CSA	125 V / 125 V	
Maximum permissible current (per branch)	1 A	
Maximum total current (voltage supply)	3 A (per byte)	
Ambient temperature (operation)	-20 °C ... 50 °C	
Mounting position	any	
Standards/regulations	IEC 60664 , DIN EN 50178	
Connection method	Push-in connection	
	Field level	
	Controller level	
Connection data solid/stranded/AWG	0.14 ... 2.5 mm ² / 0.14 ... 2.5 mm ² / 26 - 14	
Dimensions	72.1 mm / 56 mm	

Technical data		
Maximum permissible operating voltage	60 V AC/DC	
Maximum permissible operating voltage UL / CSA	125 V / 125 V	
Maximum permissible current (per branch)	1 A	
Maximum total current (voltage supply)	3 A (per byte)	
Ambient temperature (operation)	-20 °C ... 50 °C	
Mounting position	any	
Standards/regulations	IEC 60664 , DIN EN 50178	
Connection method	Push-in connection	
	Field level	
	Controller level	
Connection data solid/stranded/AWG	0.14 ... 2.5 mm ² / 0.14 ... 2.5 mm ² / 26 - 14	
Dimensions	72.1 mm / 56 mm	

Ordering data		
Description	No. of pos.	Module width W
VARIOFACE termination board , for eight channels, each with an additional terminal block per signal for a common minus potential		
- with screw connection	14	50 mm
- with Push-in connection	14	52 mm
VARIOFACE termination board , for eight channels, each with an additional terminal block per signal for a common plus potential		
- with screw connection	14	50 mm
- with Push-in connection	14	52 mm

Ordering data		
Type	Order No.	Pcs./ Pkt.
VIP-2/SC/FLK14/8M/PLC	2322281	1
VIP-2/SC/FLK14/8P/PLC	2322294	1

Ordering data		
Type	Order No.	Pcs./ Pkt.
VIP-2/PT/FLK14/8M/PLC	2904283	1
VIP-2/PT/FLK14/8P/PLC	2904284	1

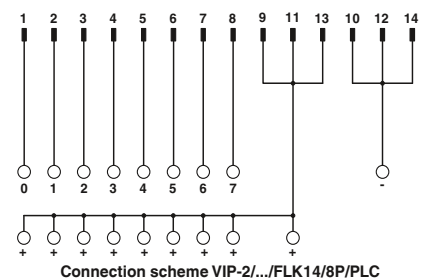
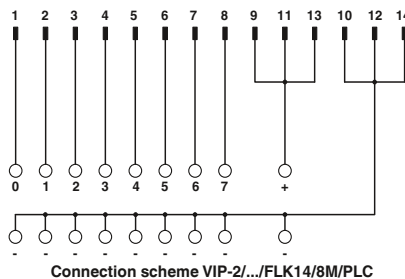

Termination boards in 2-conductor connection technology for 32 channels

These VARIOFACE modules are used in combination with 50-pos. system cables and the relevant front adapters.

The following module types with 2-conductor connection technology are available:

FLKM 50/32M/PLC

- Byte-wise marking
- For digital I/O modules
- Negative connection per signal.

FLKM 50/32P/PLC

- Byte-wise marking
- For digital I/O modules
- Positive connection per signal.

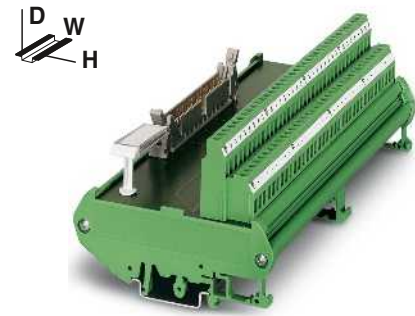

Passive termination boards with screw connection



Technical data

Maximum permissible operating voltage	60 V DC
Maximum permissible operating voltage UL / CSA	125 V / -
Maximum permissible current (per branch)	1 A
Maximum total current (voltage supply)	8 A (per byte)
Ambient temperature (operation)	-20 °C ... 50 °C
Mounting position	any
Standards/regulations	DIN EN 50178 , IEC 60664
Connection method	Field level Controller level
Connection data solid/stranded/AWG	0.2 ... 4 mm ² / 0.2 ... 2.5 mm ² / 24 - 12
Dimensions	H / D 90 mm / 68 mm

Ordering data

Description	No. of pos.	Module width W	Type	Order No.	Pcs./ Pkt.
VARIOFACE termination board , for 32 channels, each with an additional terminal block per signal for a common minus potential	50	192 mm	FLKM 50/32M/PLC	2289719	1
VARIOFACE termination board , for 32 channels, each with an additional terminal block per signal for a common plus potential	50	192 mm	FLKM 50/32P/PLC	2291121	1

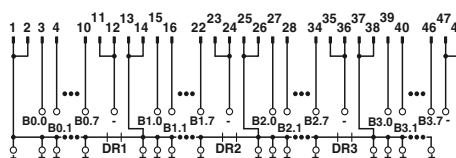

Connection scheme: FLKM 50/32P/PLC

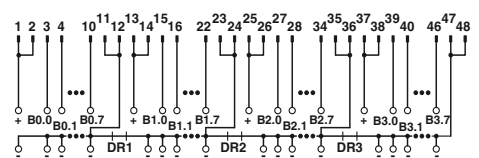

Connection scheme: FLKM 50/32M/PLC

System cabling for controllers

Controller-specific system cabling

Termination boards with fuses in 2-conductor connection technology

These VARIOFACE modules are used in combination with 14 or 50-pos. system cables and the relevant front adapters.

The following module types with fuses and 2-conductor connection technology are available:

FLKM 14/8M/SI/PLC (for 8 channels) FLKM 50/32M/SI/PLC (for 32 channels)

- Byte-wise marking
- Can be used for digital I/O modules
- Pluggable fuse (IEC 127-3, 1AF) per signal path (F1)
- Pluggable fuse (IEC 127-3, 2AF) per voltage supply (F2)
- Negative connection per signal.

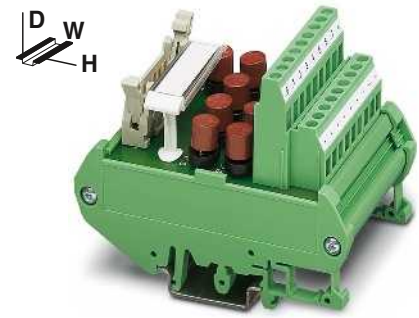

Passive fuse modules for 8 or 32 channels



Technical data

	FLKM 14/8M/SI/PLC	FLKM 50/32M/SI/PLC
Maximum permissible operating voltage	60 V DC	60 V DC
Maximum permissible operating voltage UL / CSA	125 V / -	125 V / -
Maximum permissible current (per branch)	1 A	1 A
Maximum total current (voltage supply)	2 A	2 A (per byte)
Ambient temperature (operation)	-20 °C ... 50 °C	-20 °C ... 50 °C
Mounting position	any	any
Standards/regulations	DIN EN 50178 , IEC 60664	
Connection method	Field level Screw connection	Controller level Screw connection
Connection data solid/stranded/AWG	0.2 ... 4 mm ² / 0.2 ... 2.5 mm ² / 24 - 12	IDC/FLK pin strip
Dimensions	H / D	90 mm / 68 mm

Ordering data

Description	No. of pos.	Module width W	Type	Order No.	Pcs./Pkt.
VARIOFACE module , for eight channels, each with an additional terminal block and fuse per signal, (common minus potential)	14	57 mm	FLKM 14/8M/SI/PLC	2294487	1
VARIOFACE module , for 32 channels, each with an additional terminal block and fuse per signal, (common minus potential)	50	192 mm	FLKM 50/32M/SI/PLC	2294490	1

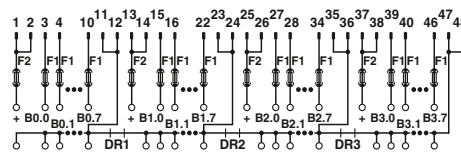

Connection scheme: FLKM 50/32M/SI/PLC

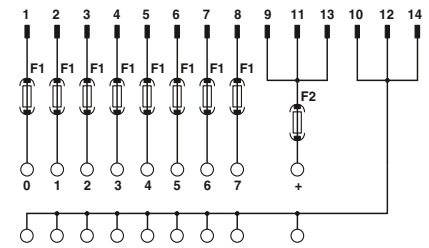

Connection scheme: FLKM 14/8M/SI/PLC

VIP initiator modules for 8 channels

These VIP - VARIOFACE Professional modules are used in combination with 14-pos. system cables and the relevant front adapters.

Features:

- Byte-wise marking
- For digital I/O modules
- Positive and negative connection per signal
- With LED as an option

Notes:
For marking systems (e.g., "ZB 22:UNBEDRUCKT"; Order No. 0811862) and mounting material, see Catalog 3.

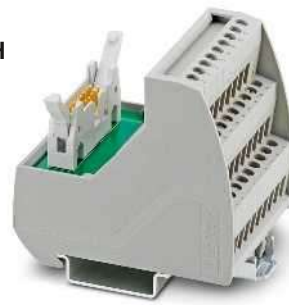

Initiator modules with screw connection



Initiator modules with Push-in connection



Maximum permissible operating voltage
Maximum permissible operating voltage UL / CSA

Maximum permissible current (per branch)
Maximum total current (voltage supply)

Ambient temperature (operation)
Mounting position

Standards/regulations

Connection method

Connection data solid/stranded/AWG

Dimensions

Field level
Controller level

H / D

Technical data

VIP-3/SC/FLK14/8IM/PLC	VIP-3/SC/FLK14/8IM/LED/PLC
60 V DC	24 V DC
125 V / -	24 V / 24 V
1 A	1 A
3 A	3 A
-20 °C ... 50 °C	-20 °C ... 50 °C
any	any
IEC 60664 , DIN EN 50178	
Screw connection	Screw connection
IDC/FLK pin strip	IDC/FLK pin strip
0.2 ... 4 mm ² / 0.2 ... 2.5 mm ² / 24 - 12	
69 mm / 62 mm	

Technical data

VIP-3/PT/FLK14/8IM/PLC	VIP-3/PT/FLK14/8IM/LED/PLC
60 V AC/DC	24 V DC
125 V / 125 V	24 V / 24 V
1 A	1 A
3 A	3 A
-20 °C ... 50 °C	-20 °C ... 50 °C
any	any
IEC 60664 , DIN EN 50178	
Push-in connection	Push-in connection
IDC/FLK pin strip	IDC/FLK pin strip
0.14 ... 2.5 mm ² / 0.14 ... 2.5 mm ² / 26 - 14	
75.8 mm / 63 mm	

Ordering data

Type	Order No.	Pcs./ Pkt.
VIP-3/SC/FLK14/8IM/PLC	2322278	1
VIP-3/SC/FLK14/8IM/LED/PLC	2322265	1

Ordering data

Type	Order No.	Pcs./ Pkt.
VIP-3/PT/FLK14/8IM/PLC	2904282	1
VIP-3/PT/FLK14/8IM/LED/PLC	2904281	1

Description	No. of pos.	Module width W
VARIOFACE initiator module , for connecting 8 PNP initiators, with an additional positive and negative terminal block each per signal		
- with screw connection	14	52.3 mm
- with Push-in connection	14	52 mm
VARIOFACE initiator module with LED , for connecting 8 PNP initiators, with an additional positive and negative terminal block each per signal		
- with screw connection	14	52.3 mm
- with Push-in connection	14	52 mm

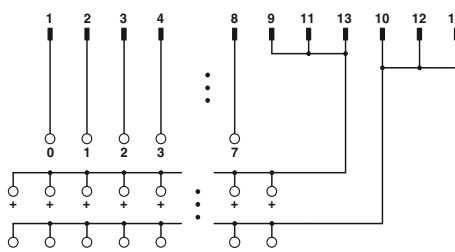

Connection scheme VIP-3/.../FLK14/8IM/PLC

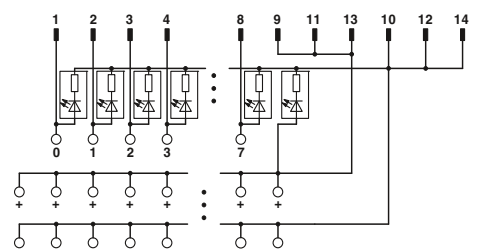

Connection scheme VIP-3/.../FLK14/8IM/LED/PLC

System cabling for controllers

Controller-specific system cabling

Initiator modules for 32 channels

These VARIOFACE modules are used in combination with 50-pos. system cables and the relevant front adapters for digital I/O modules.

Features:

- Byte-wise marking
- Positive and negative connection per signal
- With LED as an option

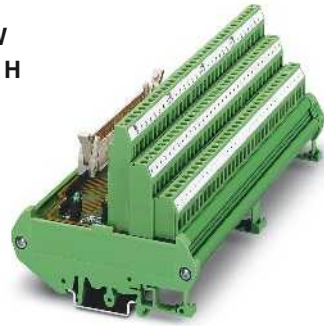

Initiator modules for 32 channels, with screw connection

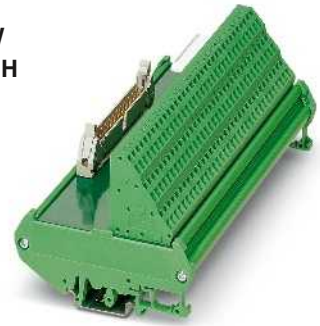

Initiator modules for 32 channels, with spring-cage connection



		Technical data		Technical data	
Maximum permissible operating voltage		... 50/32 IM	... 50/32 IM/LA	60 V DC	60 V DC
Maximum permissible operating voltage UL / CSA		60 V DC	30 V DC	- / -	- / -
		125 V / -	24 V / -		
Maximum permissible current (per branch)		1 A	1 A	1 A	1 A
Maximum total current (voltage supply)		2 A (per byte)	2 A (per byte)	2 A (per byte)	2 A (per byte)
Status indication		-	LED	-	-
Ambient temperature (operation)		-20 °C ... 50 °C	-20 °C ... 50 °C	-20 °C ... 50 °C	-20 °C ... 50 °C
Mounting position		any	any	any	any
Standards/regulations		DIN EN 50178 , IEC 60664	DIN EN 50178 , IEC 60664	DIN EN 50178 , IEC 60664	DIN EN 50178 , IEC 60664
Connection method	Field level	Screw connection	Screw connection	Spring-cage connection	Spring-cage connection
	Controller level	IDC/FLK pin strip	IDC/FLK pin strip	IDC/FLK pin strip	IDC/FLK pin strip
Connection data solid/stranded/AWG		0.2 ... 4 mm ² / 0.2 ... 2.5 mm ² / 24 - 12	0.2 ... 2.5 mm ² / 0.2 ... 1.5 mm ² / 24 - 12	0.2 ... 2.5 mm ² / 0.2 ... 1.5 mm ² / 24 - 12	0.2 ... 2.5 mm ² / 0.2 ... 1.5 mm ² / 24 - 12
Dimensions	H / D	90 mm / 81 mm	90 mm / 81 mm	90 mm / 73.5 mm	90 mm / 73.5 mm

			Ordering data			Ordering data		
Description	No. of pos.	Module width W	Type	Order No.	Pcs./ Pkt.	Type	Order No.	Pcs./ Pkt.
VARIOFACE initiator module, for connection of 32 PNP initiators	50	180 mm	FLKMS 50/32IM/PLC	2284523	1			
VARIOFACE initiator module, as above, but with light indicator	50	180 mm	FLKMS 50/32IM/LA/PLC	2284510	1			
VARIOFACE initiator module, for connection of 32 PNP initiators	50	180 mm	FLKMS 50/32IM/ZFKDS/PLC	2901389	1			

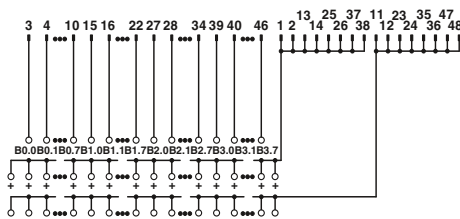

Connection scheme: FLKMS 50/32IM/PLC, ...50/32IM/ZFKDS/PLC

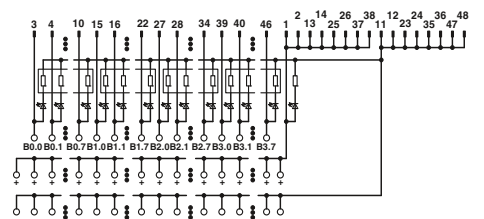

FLKMS 50/32IM/LA/PLC connection scheme

System cabling for controllers

Controller-specific system cabling

Termination boards with knife disconnect terminal blocks

These VARIOFACE modules with knife disconnection and test connection for each signal (2 or 2.3 mm Ø test plug) are used in combination with the respective front adapters.

FLKM14/KDS3-MT/PPA/PLC

(for 8 channels)

FLKM 50/KDS3-MT/PPA/PLC

(for 32 channels)

- Byte-wise marking
- Can be used for digital I/O modules

FLKM-2FLK14/KDS3-MT/PPA/S7

- Numerical marking (1-20)
- Specifically for S7-300 (in conjunction with the front adapter FLKM 14-PA-S300, Order No. [2299770](#))

FLKM 50/KDS3-MT/PPA/S7-300

- Numerical marking (1-40)
- Specifically for S7-300 (in conjunction with the front adapter FLKM 50-PA-S300, Order No. [2294445](#))

FLKM 50/KDS3-MT/PPA/AN/PLC

- Numerical marking (1-50)
- Specifically for S7-400 (in conjunction with the front adapter FLKM 50-PA-S400 (3-48) Order No. [2294908](#))

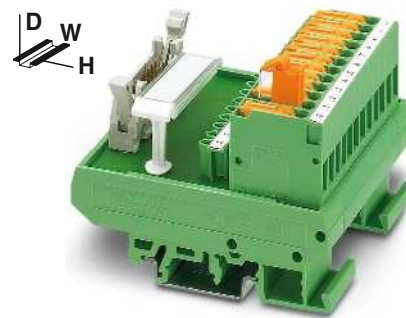

Passive termination boards for 8 or 32 channels with knife disconnect terminal blocks



Technical data

FLKM...14/KDS 3-MT...	FLKM 50/KDS 3-MT...
60 V DC	60 V DC
24 V / -	24 V / -
1 A	1 A
3 A	2 A (per byte)
-20 °C ... 50 °C	-20 °C ... 50 °C
any	any
DIN EN 50178 , IEC 60664	
Screw connection with disconnect knife	Screw connection with disconnect knife
IDC/FLK pin strip	IDC/FLK pin strip
0.2 ... 4 mm ² / 0.2 ... 2.5 mm ² / 24 - 12	
77 mm / 61 mm	

Ordering data

Type	Order No.	Pcs./Pkt.
FLKM 14/KDS3-MT/PPA/PLC	2290423	1
FLKM 50/KDS3-MT/PPA/PLC	2290614	1
FLKM-2FLK14/KDS3-MT/PPA/S7	2295062	1
FLKM 50/KDS3-MT/PPA/S7-300	2304490	1
FLKM 50/KDS3-MT/PPA/AN/PLC	2291587	1

Maximum permissible operating voltage	
Maximum permissible operating voltage UL / CSA	
Maximum permissible current (per branch)	
Maximum total current (voltage supply)	
Ambient temperature (operation)	
Mounting position	
Standards/regulations	
Connection method	Field level
	Controller level
Connection data solid/stranded/AWG	
Dimensions	H / D

Description	No. of pos.	Module width W
VARIOFACE termination board, for eight channels, with knife disconnect terminal blocks and test sockets to the field and the system	14	67 mm
VARIOFACE termination board, for 32 channels, with knife disconnect terminal blocks and test sockets to the field and the system	50	214 mm
VARIOFACE termination board, for SIMATIC S7-300 with SIMATIC-specific marking (1-20), knife disconnect terminal blocks, and test sockets to the field and the system	14	113 mm
VARIOFACE termination board, as above, but with SIMATIC-specific marking (1-40)	50	214 mm
VARIOFACE termination board, as above, but for SIMATIC S7-400 with SIMATIC-specific marking (3-48)	50	259 mm

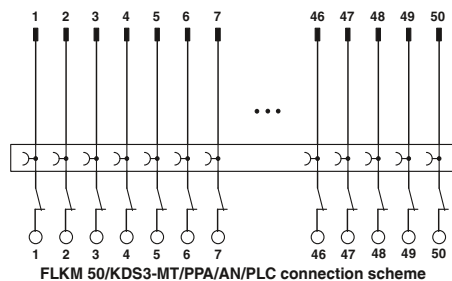

FLKM 50/KDS3-MT/PPA/AN/PLC connection scheme

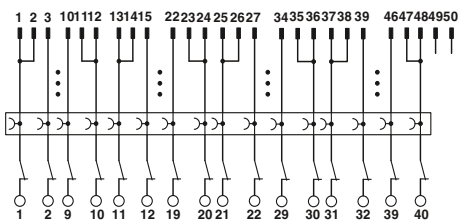

FLKM 50/KDS3-MT/PPA/S7-300 connection scheme

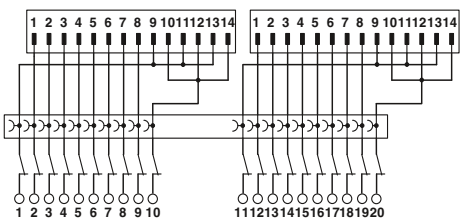

FLKM-2FLK14/KDS3-MT/PPA/S7 connection scheme

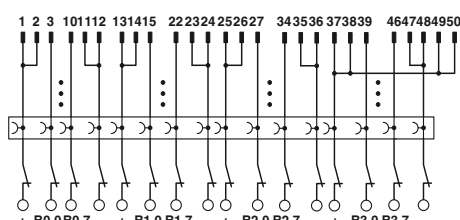

FLKM 50/KDS3-MT/PPA/PLC connection scheme

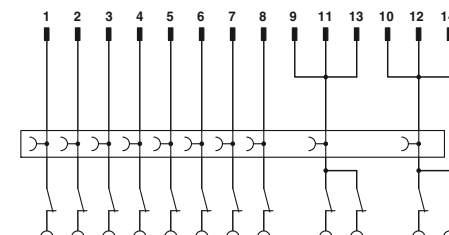

FLKM 14/KDS3-MT/PPA/PLC connection scheme

Simulation module with switches

These VARIOFACE modules enable simple simulation of the control and peripheral hardware for 8 signals.

The UM 45-DI/DO/S/LA/SIM8 switch module is equipped with a COMBICON screw connector for single-conductor wiring for signal transmission. Alternatively, connection to the PLC system cabling is possible via a 14-pos. IDC/FLK pin strip. Connection to the front adapters of the PLC system cabling is possible via 14-pos. system cables with IDC/FLK socket strip.

Each signal path is allocated an LED which signals the “high active” signal state. The supply voltage to the modules is signaled via a green LED.

Notes:
Type of housing: Terminal blocks: polyamide PA, non-reinforced, color: green. Housing: PVC
Marking systems and mounting material See Catalog 3

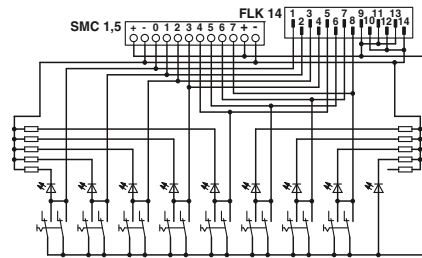

Maximum permissible operating voltage
Maximum permissible current (per branch)
Maximum total current (voltage supply)

Ambient temperature (operation)
Mounting position
Standards/regulations
Connection data solid/stranded/AWG
Dimensions

H / D

Description	No. of pos.	Module width W
VARIOFACE switch module , for simulation		75 mm

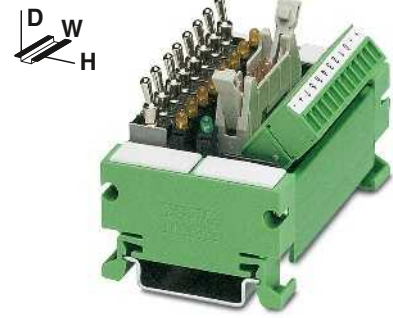

Switch module

Technical data

30 V DC
1 A
8 A (+, - terminal block)

-20 °C ... 50 °C
any
DIN EN 50178 , IEC 60664
0.14 ... 1.5 mm² / 0.14 ... 1.5 mm² / 28 - 16
45 mm / 51 mm

Ordering data

Type	Order No.	Pcs./ Pkt.
UM 45-DI/DO/S/LA/SIM8	2968205	1

Simulation module for indication

These VARIOFACE modules enable simple simulation of the control and peripheral hardware for 8 signals.

The UM 45-DO/LA/SIM8 indicator module is equipped with a COMBICON screw connector for single-conductor wiring for signal transmission. Alternatively, connection to the PLC system cabling is possible via a 14-pos. IDC/FLK pin strip. Connection to the front adapters of the PLC system cabling is possible via 14-pos. system cables with IDC/FLK socket strip.

Each signal path is allocated an LED which signals the “high active” signal state. The supply voltage to the modules is signaled via a green LED.

Notes:
Type of housing: Terminal blocks: polyamide PA, non-reinforced, color: green. Housing: PVC
Marking systems and mounting material See Catalog 3

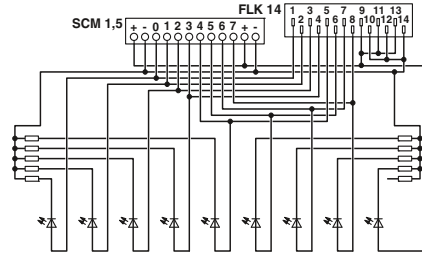

Maximum permissible operating voltage
Maximum permissible current (per branch)
Maximum total current (voltage supply)

Ambient temperature (operation)
Mounting position
Standards/regulations
Connection data solid/stranded/AWG
Dimensions

H / D

Description	No. of pos.	Module width W
VARIOFACE indicator module , for simulation		75 mm

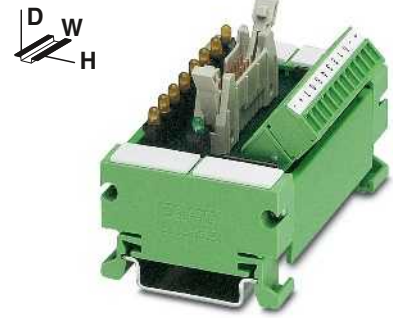

Indicator module

Technical data

30 V DC
1 A
8 A (+, - terminal block)

-20 °C ... 50 °C
any
DIN EN 50178 , IEC 60664
0.14 ... 1.5 mm² / 0.14 ... 1.5 mm² / 28 - 16
45 mm / 51 mm

Ordering data

Type	Order No.	Pcs./ Pkt.
UM 45-DO/LA/SIM8	2968195	1

System cabling for controllers

Controller-specific system cabling

Output modules with relays, one N/O contact

These VARIOFACE output modules are used in combination with the respective front adapters.

- Plug-in miniature relays, each with an N/O contact
- Universal applications from 1 mA to 3 A continuous current through 2-layer double contact with hard gold plating
- Overall width of just 55 mm (8 channels) or 202 mm (32 channels)
- LED status display for each signal path and supply voltage
- Freewheeling and reverse polarity protection diode for each signal path



Output module with eight miniature relays, 1 N/O contact

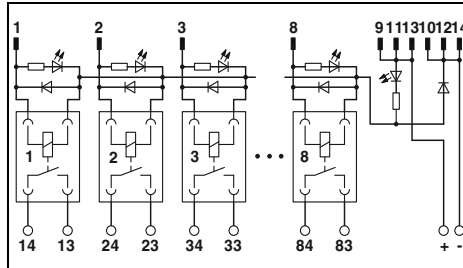

Technical data

Coil side	
Operating voltage U_N	24 V DC
Typical input current at U_N	6.5 mA
Typical response time at U_N	5 ms
Typical release time at U_N	15 ms
Input circuit	Freewheeling diode, reverse polarity protection
Status indicator per channel	Yellow LED
Connection method	IDC/FLK pin strip
No. of pos.	14
Contact side	
Contact type	1 N/O contact (double contact)
Contact material	AgNi, 5 µm hard gold-plated
Max. switching voltage	250 V AC / 125 V DC
Minimum switching voltage	5 V
Maximum switch-on current	5 A
Limiting continuous current	3 A
Minimum switching current	1 mA
Maximum interrupting rating:	24 V DC 72 W 48 V DC 60 W 60 V DC 50 W 110 V DC 50 W 250 V AC 750 VA
Connection method	Screw connection
Connection data solid/stranded/AWG	0.14 ... 1.5 mm ² / 0.14 ... 1.5 mm ² / 26 - 14
General data	
Rated insulation voltage	260 V AC
Rated surge voltage	4 kV (basic insulation)
Degree of pollution / Overvoltage category	2 / III
Ambient temperature (operation)	-20 °C ... 50 °C
Nominal operating mode	100% operating factor
Mechanical service life	2 x 10 ⁷ cycles
Standards/regulations	DIN EN 50178 , IEC 60664
Mounting position	any
Mounting	In rows with zero spacing
Dimensions	90 mm / 58 mm
EMC note	Class A product, see page 605

Ordering data

Description	Module width W
VARIOFACE output module , with 8 miniature relays, plugged in, for 24 V DC (including relays)	56
VARIOFACE output module , with 32 miniature relays, plugged in, for 24 V DC (including relays)	202

Accessories

Plug-in miniature relays	REL-MR-G 24/1	2961037	8
---------------------------------	---------------	---------	---

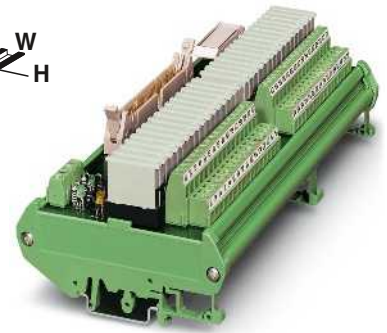

Output module with 32 miniature relays, 1 N/O contact

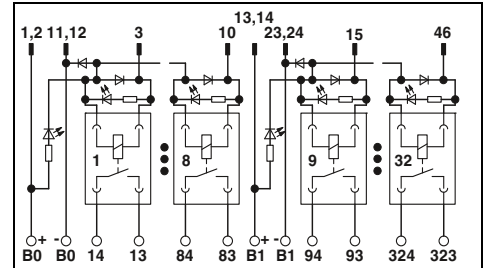

Technical data

Coil side	
Operating voltage U_N	24 V DC
Typical input current at U_N	6.5 mA
Typical response time at U_N	5 ms
Typical release time at U_N	15 ms
Input circuit	Freewheeling diode, reverse polarity protection
Status indicator per channel	Yellow LED
Connection method	IDC/FLK pin strip
No. of pos.	50
Contact side	
Contact type	1 N/O contact (double contact)
Contact material	AgNi, 5 µm hard gold-plated
Max. switching voltage	250 V AC / 125 V DC
Minimum switching voltage	5 V
Maximum switch-on current	5 A
Limiting continuous current	3 A
Minimum switching current	1 mA
Maximum interrupting rating:	24 V DC 72 W 48 V DC 60 W 60 V DC 50 W 110 V DC 50 W 250 V AC 750 VA
Connection method	Screw connection
Connection data solid/stranded/AWG	0.14 ... 1.5 mm ² / 0.14 ... 1.5 mm ² / 26 - 16
General data	
Rated insulation voltage	260 V AC
Rated surge voltage	4 kV (basic insulation)
Degree of pollution / Overvoltage category	2 / III
Ambient temperature (operation)	-20 °C ... 50 °C
Nominal operating mode	100% operating factor
Mechanical service life	2 x 10 ⁷ cycles
Standards/regulations	DIN EN 50178 , IEC 60664
Mounting position	any
Mounting	In rows with zero spacing
Dimensions	90 mm / 58 mm
EMC note	Class A product, see page 605

Ordering data

Description	Module width W
VARIOFACE output module , with 32 miniature relays, plugged in, for 24 V DC (including relays)	202

Accessories

Plug-in miniature relays	REL-MR-G 24/1	2961037	8
---------------------------------	---------------	---------	---

Output modules with relay, 1 PDT

These VARIOFACE output modules are used in combination with the respective front adapters.

Like the front adapters, the modules are connected via 14-pos. or 50-pos. system cables. The following features characterize these relay modules:

- Plug-in miniature relays, each with a PDT contact
- Overall width of just 80 mm (8 channels) or 271 mm (32 channels)
- LED status display for each signal path and supply voltage
- Freewheeling diode for each signal path



Output module with eight miniature relays, 1 PDT

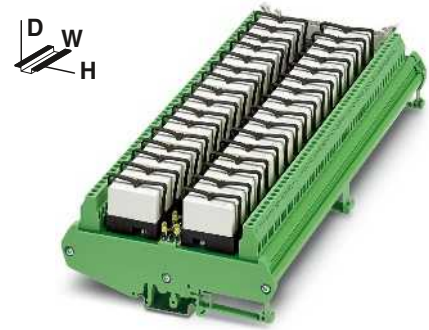

Output module with 32 miniature relays, 1 PDT

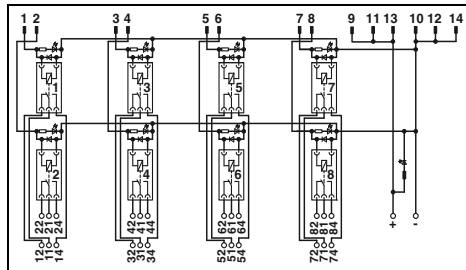

Technical data

Coil side	
Operating voltage U_N	24 V DC
Typical input current at U_N	18 mA
Typical response time at U_N	8 ms
Typical release time at U_N	10 ms
Input circuit	Freewheeling diode
Status indicator per channel	Yellow LED
Connection method	IDC/FLK pin strip
No. of pos.	14
Contact side	
Contact type	Single contact, 1-PDT
Contact material	AgNi
Max. switching voltage	250 V AC/DC
Minimum switching voltage	12 V AC/DC
Limiting continuous current	5 A
Minimum switching current	10 mA
Maximum interrupting rating:	24 V DC 120 W 48 V DC 58 W 60 V DC 48 W 110 V DC 50 W 220 V DC 80 W 250 V AC 1250 VA
Connection method	Screw connection
Connection data solid/stranded/AWG	0.2 ... 4 mm ² / 0.2 ... 2.5 mm ² / 24 - 12
General data	
Rated insulation voltage	260 V AC
Rated surge voltage	4 kV (Basic insulation between output contact current paths) 6 kV (Safe isolation and reinforced insulation between input circuit and output contact paths)
Degree of pollution / Overvoltage category	2 / III
Ambient temperature (operation)	-20 °C ... 50 °C
Nominal operating mode	100% operating factor
Mechanical service life	3 x 10 ⁷ cycles
Standards/regulations	DIN EN 50178 , IEC 60664
Mounting position	any
Mounting	In rows with zero spacing
Dimensions	123 mm / 68 mm
EMC note	Class A product, see page 605

Ordering data

Description	Module width W	Type	Order No.	Pcs./ Pkt.
VARIOFACE output module, for 24 V DC (incl. relay)				
- with 8 miniature relays	80	UM- 8 RM/RT-G24/21/PLC	2968386	1
- with 32 miniature relays	271			

Accessories

Plug-in miniature power relays, with power contacts	Order No.	Pcs.
REL-MR- 24DC/21HC	2961312	10

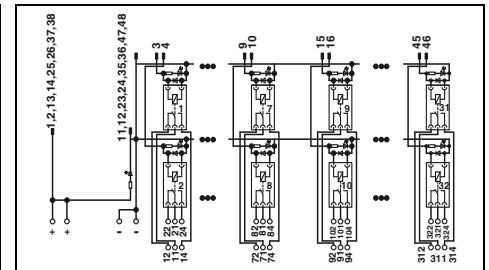

Technical data

Coil side	
Operating voltage U_N	24 V DC
Typical input current at U_N	18 mA
Typical response time at U_N	8 ms
Typical release time at U_N	10 ms
Input circuit	Freewheeling diode
Status indicator per channel	Yellow LED
Connection method	IDC/FLK pin strip
No. of pos.	50
Contact side	
Contact type	Single contact, 1-PDT
Contact material	AgNi
Max. switching voltage	250 V AC/DC
Minimum switching voltage	12 V AC/DC
Limiting continuous current	5 A
Minimum switching current	10 mA
Maximum interrupting rating:	120 W 58 W 48 W 50 W 80 W 1250 VA
Connection method	Screw connection
Connection data solid/stranded/AWG	0.2 ... 4 mm ² / 0.2 ... 2.5 mm ² / 24 - 12
General data	
Rated insulation voltage	260 V AC
Rated surge voltage	4 kV (Basic insulation between output contact current paths) 6 kV (Safe isolation and reinforced insulation between input circuit and output contact paths)
Degree of pollution / Overvoltage category	2 / III
Ambient temperature (operation)	-20 °C ... 50 °C
Nominal operating mode	100% operating factor
Mechanical service life	3 x 10 ⁷ cycles
Standards/regulations	DIN EN 50178 , IEC 60664
Mounting position	any
Mounting	In rows with zero spacing
Dimensions	123 mm / 68 mm
EMC note	Class A product, see page 605

Ordering data

Description	Module width W	Type	Order No.	Pcs./ Pkt.
VARIOFACE output module, for 24 V DC (incl. relay)				
- with 8 miniature relays	80	UM- 8 RM/RT-G24/21/PLC	2968386	1
- with 32 miniature relays	271	UM-32 RM/RT-G24/21/PLC	2968373	1

Accessories

Plug-in miniature power relays, with power contacts	Order No.	Pcs.
REL-MR- 24DC/21HC	2961312	10

Controller-specific system cabling

Output modules with relay, 1 PDT

These VARIOFACE output modules are used in combination with the respective front adapters.

Like the front adapters, the modules are connected via 14-pos. or 50-pos. system cables. The following features characterize these relay modules:

- Plug-in miniature relays, each with a PDT contact
- LED status display for each signal path and supply voltage
- Freewheeling and reverse polarity protection diode for each signal path

With the 32-channel version, the system cable is connected to the 16-channel UMK-16R.../KSR-G24/21/PLC base modules. The UMK-16R.../KSR-G24/21/E/PLC output extension modules with a further 16 channels are coupled to the base modules via a 20-position flat-ribbon cable (length: 10 cm).

Notes:

The connection cable between the base and the extension modules is delivered with the extension unit.

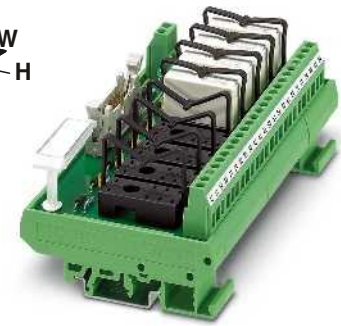

**Output module
with eight miniature relays,
1 PDT**

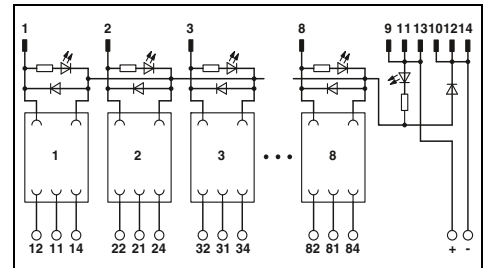

Technical data

Coil side	
Operating voltage U_N	24 V DC
Input circuit	Freewheeling diode, reverse polarity protection
Operating voltage display	Green LED
Status indicator per channel	Yellow LED
Connection method	IDC/FLK pin strip
No. of pos.	14
Contact side	
Contact type	1 PDT
Max. switching voltage	250 V AC/DC
Limiting continuous current	5 A
Connection method	Screw connection
Connection data solid/stranded/AWG	0.2 ... 4 mm ² / 0.2 ... 2.5 mm ² / 24 - 12
General data	
Rated insulation voltage	260 V AC
Rated surge voltage	4 kV (Basic insulation between output contact current paths) 6 kV (Safe isolation and reinforced insulation between input circuit and output contact paths)
Degree of pollution / Overvoltage category	2 / III
Ambient temperature (operation)	-20 °C ... 50 °C
Standards/regulations	DIN EN 50178 , IEC 60664
Mounting position	any
Mounting	In rows with zero spacing
Dimensions	77 mm / 59 mm
EMC note	Class A product, see page 605

Ordering data

Description	Module width W	Type	Order No.	Pcs./ Pkt.
VARIOFACE output module , for 24 V DC - with 8 plug-in bases including relay	135	UMK- 8 RM/KSR-G 24/21/PLC	2979485	1
- with 8 plug-in bases without relay	135	UMK- 8 RELS/KSR-G24/21/PLC	2974914	1
VARIOFACE output basic module , for 24 V DC - with 16 plug-in bases including relay	259			
- with 16 plug-in bases without relay	259			
VARIOFACE output extension module , for 24 V DC - with 16 plug-in bases including relay	259			
- with 16 plug-in bases without relay	259			

Accessories

Plug-in miniature power relays, with power contacts	REL-MR- 24DC/21HC	2961312	10
--	--------------------------	----------------	----

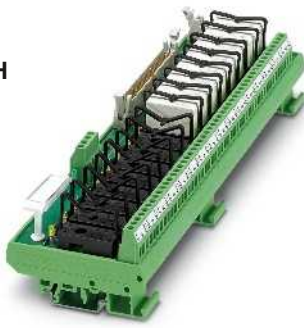

**Output base module
with 16 miniature relays,
1 PDT**

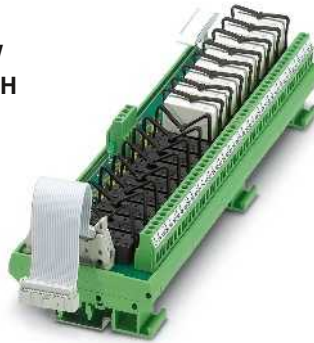

**Output extension module
with 16 miniature relays,
1 PDT**

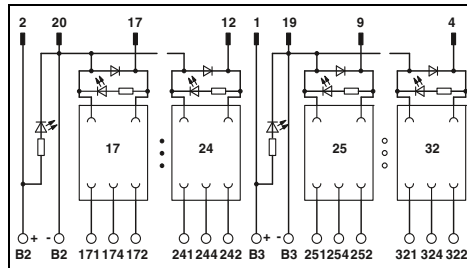
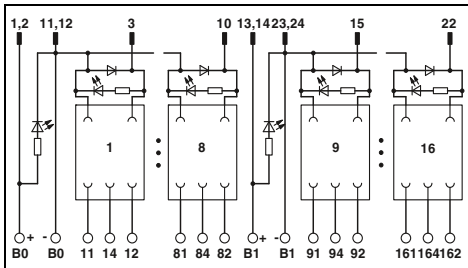

Technical data

Technical data

24 V DC
Freewheeling diode, reverse polarity protection
Green LED
Yellow LED
IDC/FLK pin strip
50

24 V DC
Freewheeling diode, reverse polarity protection
Green LED
Yellow LED
IDC/FLK pin strip
20

1 PDT
250 V AC/DC
5 A
Screw connection
0.2 ... 4 mm² / 0.2 ... 2.5 mm² / 24 - 12

1 PDT
250 V AC/DC
5 A
Screw connection
0.2 ... 4 mm² / 0.2 ... 2.5 mm² / 24 - 12

260 V AC
4 kV (Basic insulation between output contact current paths)
6 kV (Safe isolation and reinforced insulation between input circuit and output contact paths)

260 V AC
4 kV (Basic insulation between output contact current paths)
6 kV (Safe isolation and reinforced insulation between input circuit and output contact paths)

2 / III
-20 °C ... 50 °C
DIN EN 50178 , IEC 60664
any
In rows with zero spacing
77 mm / 59 mm
Class A product, see page 605

2 / III
-20 °C ... 50 °C
DIN EN 50178 , IEC 60664
any
In rows with zero spacing
77 mm / 59 mm
Class A product, see page 605

Ordering data

Ordering data

Type	Order No.	Pcs./ Pkt.
UMK-16 RM/KSR-G 24/21/PLC	2979498	1
UMK-16 RELS/KSR-G24/21/PLC	2974901	1

Type	Order No.	Pcs./ Pkt.
UMK-16 RM/KSR-G 24/21/E/PLC	2979508	1
UMK-16 RELS/KSR-G24/21/E/PLC	2974891	1

Accessories

Accessories

REL-MR- 24DC/21HC	2961312	10
-------------------	---------	----

REL-MR- 24DC/21HC	2961312	10
-------------------	---------	----

System cabling for controllers

Controller-specific system cabling

Output module for relays

- 2 PDTs

- 1 PDT with disconnect terminal blocks

These VARIOFACE output modules are used in combination with the respective front adapters.

8 channels are controlled via 14-pos. cables. All modules feature the following:

- Plug-in miniature relays
- LED status indicator and freewheeling diode per signal path
- Supply voltage indicator (LED)
- Polarity protection diode

With the 32-channel version (1 PDT with knife disconnect terminal blocks), the 50-pos. system cable is connected to the base module with 16 channels.

The output extension module with a further 16 channels is coupled to the base module via a 20-pos. flat-ribbon cable (length: 10 cm).

Notes:

The connection cable between the base and the extension modules is delivered with the extension unit.

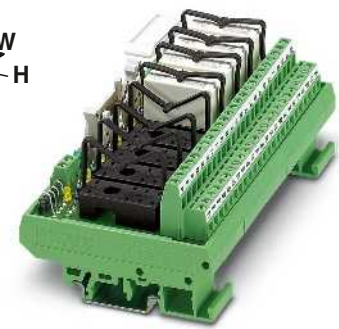

Output module for 8 miniature relays, 2 PDTs

ERC

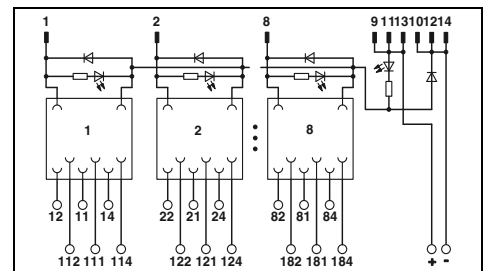

Technical data

Coil side	
Operating voltage U_N	24 V DC
Input circuit	Freewheeling diode
Operating voltage display	Green LED
Status indicator per channel	Yellow LED
Connection method	IDC/FLK pin strip
No. of pos.	14
Contact side	
Contact type	2 PDT
Max. switching voltage	250 V AC/DC
Limiting continuous current	3 A
Connection method	Screw connection
Connection data solid/stranded/AWG	0.14 ... 1.5 mm ² / 0.14 ... 1.5 mm ² / 26 - 14
General data	
Rated insulation voltage	260 V AC
Rated surge voltage	4 kV (Basic insulation between output contact current paths) 6 kV (Safe isolation and reinforced insulation between input circuit and output contact paths)
Degree of pollution / Overvoltage category	2 / III
Ambient temperature (operation)	-20 °C ... 50 °C
Standards/regulations	DIN EN 50178 , IEC 60664
Mounting position	any
Mounting	In rows with zero spacing
Dimensions	77 mm / 59 mm
EMC note	Class A product, see page 605

Ordering data

Description	Module width W	Type	Order No.	Pcs./ Pkt.
VARIOFACE output module , for 24 V DC (2 PDTs)				
- with 8 plug-in bases without relay	135			
VARIOFACE output module with knife disconnect terminal blocks , for 24 V DC (1 PDT)				
- with 8 plug-in bases without relay	145	UMK- 8 RELS/KSR-G24/21-21/PLC	2976187	1
VARIOFACE output module with knife disconnect terminal blocks , for 24 V DC (1 PDT)				
- basic module with 16 plug-in bases without relay	285			
- extension module with 16 plug-in bases without relay	285			

Accessories

Plug-in miniature power relays, with power contacts	REL-MR- 24DC/21-21	2961192	10
--	---------------------------	----------------	----

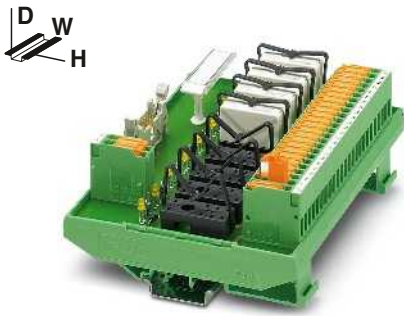

Output module for 8 miniature relays with knife disconnect terminal blocks, 1 PDT

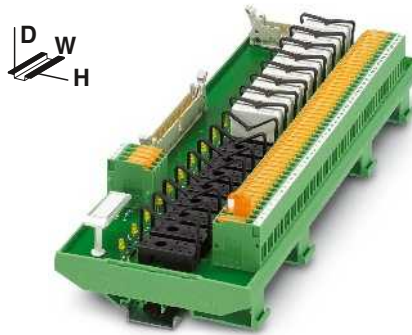

Output module for 16 miniature relays with knife disconnect terminal blocks, 1 PDT

ERC

ERC

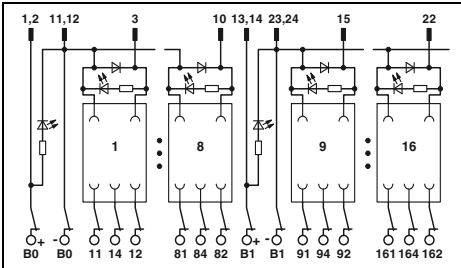
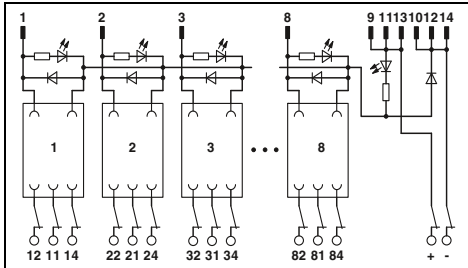

Technical data

Technical data

24 V DC
 Freewheeling diode, Reverse polarity protection
 Green LED
 Yellow LED
 IDC/FLK pin strip
 14

24 V DC
 Freewheeling diode
 Green LED
 Yellow LED
 IDC/FLK pin strip
 50

1 PDT
 250 V AC/DC
 5 A
 Screw connection with disconnect knife
 0.2 ... 4 mm² / 0.2 ... 2.5 mm² / 24 - 12

1 PDT
 250 V AC/DC
 5 A
 Screw connection with disconnect knife
 0.2 ... 4 mm² / 0.2 ... 2.5 mm² / 24 - 12

260 V AC
 4 kV (Basic insulation between output contact current paths)
 6 kV (Safe isolation and reinforced insulation between input circuit and output contact paths)

260 V AC
 4 kV (Basic insulation between output contact current paths)
 6 kV (Safe isolation and reinforced insulation between input circuit and output contact paths)

2 / III
 -20 °C ... 50 °C
 DIN EN 50178, IEC 60664
 any
 In rows with zero spacing
 111.5 mm / 59 mm
 Class A product, see page 605

2 / III
 -20 °C ... 50 °C
 DIN EN 50178, IEC 60664
 any
 In rows with zero spacing
 111.5 mm / 59 mm
 Class A product, see page 605

Ordering data

Ordering data

Type	Order No.	Pcs./ Pkt.
UM-8 RELS/KSR-G24/21/MT/PLC	2962463	1

Type	Order No.	Pcs./ Pkt.
UM-16 RELS/KSR-G24/21/MT/PLC	2962382	1
UM-16 RELS/KSR-G24/21/E/MT/PLC	2962379	1

Accessories

Accessories

REL-MR- 24DC/21HC	2961312	10
-------------------	---------	----

REL-MR- 24DC/21HC	2961312	10
-------------------	---------	----

VIP output module

These VIP – VARIOFACE Professional output modules are used in combination with the respective front adapters. Like the front adapters, the modules are connected via 14-pos. system cables.

Features:

- Plug-in miniature relays, each with a PDT contact
- LED status display for each signal path and supply voltage
- Freewheeling diode for each signal path
- Push-in connection



Output module with 8 miniature relays, 1 PDT and fuse per output circuit

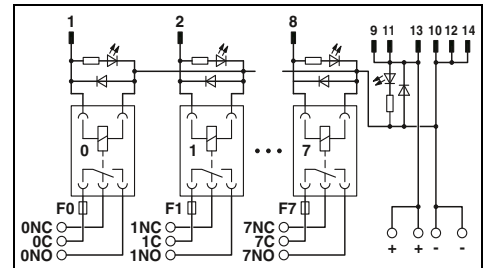

Technical data

Coil side		
Operating voltage U_N		24 V DC
Typical input current at U_N		9 mA
Typical response time at U_N		5 ms
Typical release time at U_N		8 ms
Input circuit		Freewheeling diode
Status indicator per channel		Yellow LED
Connection method		IDC/FLK pin strip
No. of pos.		14
Contact side		
Contact type		Single contact, 1-PDT
Contact material		AgSnO
Max. switching voltage		250 V AC/DC
Minimum switching voltage		12 V AC/DC
Limiting continuous current		5 A (observe derating)
Minimum switching current		10 mA
Maximum interrupting rating:		24 V DC 120 W
		48 V DC 20 W
		60 V DC 18 W
		110 V DC 23 W
		220 V DC 40 W
		250 V AC 1250 VA
Connection method		Push-in connection
Connection data solid/stranded/AWG		0.14 ... 2.5 mm ² / 0.14 ... 2.5 mm ² / 26 - 14
General data		
Ambient temperature (operation)		-20 °C ... 60 °C
Nominal operating mode		100% operating factor
Mechanical service life		2 x 10 ⁷ cycles
Standards/regulations		DIN EN 50178
Mounting position		any
Mounting		In rows with zero spacing
Dimensions	H / D	109.8 mm / 63 mm
EMC note		Class A product, see page 605

Ordering data

Description	Module width W	Type	Order No.	Pcs./ Pkt.
VARIOFACE output module, with eight miniature relays, plugged in, for 24 V DC (incl. relays)	87.6	VIP-8RPT-24DC/21/DO/FU/PLC	2903601	1

VIP input module

These VIP – VARIOFACE Professional input modules are used in combination with the respective front adapters. Like the front adapters, the modules are connected via 14-pos. system cables.

Features:

- Plug-in miniature relays, each with an N/O contact
- LED status display for each signal path and supply voltage
- Freewheeling diode for each signal path
- Push-in connection



Digital input module with 8 channels for 24 V DC



Digital input module with 8 channels for 120 V AC

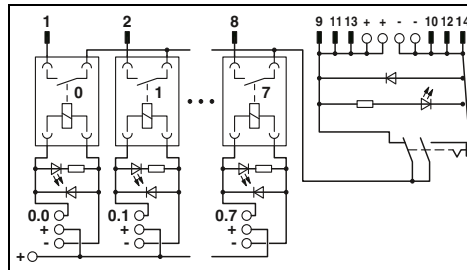

Technical data

Coil side	
Operating voltage U_N	24 V DC $\pm 10\%$ (Supply, 2 A)
Typical input current at U_N	9 mA (per channel)
Typical response time at U_N	5 ms
Typical release time at U_N	8 ms
Input circuit	Freewheeling diode
Status indicator per channel	Yellow LED
Connection method	Push-in connection
Connection data solid/stranded/AWG	0.14 ... 2.5 mm ² / 0.14 ... 2.5 mm ² / 26 - 14
Contact side	
Contact type	1 N/O contact
Contact material	AgSnO, hard gold-plated
Limiting continuous current	50 mA
Connection method	IDC/FLK pin strip
No. of pos.	14
General data	
Ambient temperature (operation)	-20 °C ... 60 °C
Nominal operating mode	100% operating factor
Mechanical service life	2 x 10 ⁷ cycles
Standards/regulations	DIN EN 50178
Mounting position	any
Mounting	In rows with zero spacing
Dimensions	109.8 mm / 63 mm
EMC note	Class A product, see page 605

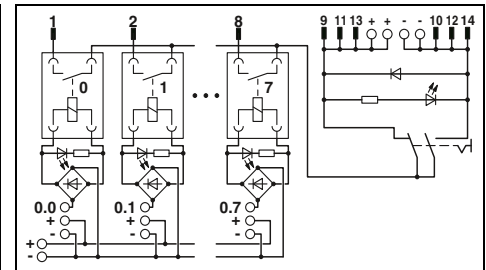

Technical data

Coil side	
Operating voltage U_N	120 V AC $\pm 10\%$ (Supply, 2 A)
Typical input current at U_N	3.5 mA (per channel)
Typical response time at U_N	6 ms
Typical release time at U_N	15 ms
Input circuit	Freewheeling diode
Status indicator per channel	Yellow LED
Connection method	Push-in connection
Connection data solid/stranded/AWG	0.14 ... 2.5 mm ² / 0.14 ... 2.5 mm ² / 26 - 14
Contact side	
Contact type	1 N/O contact
Contact material	AgSnO, hard gold-plated
Limiting continuous current	50 mA
Connection method	IDC/FLK pin strip
No. of pos.	14
General data	
Ambient temperature (operation)	-20 °C ... 60 °C
Nominal operating mode	100% operating factor
Mechanical service life	2 x 10 ⁷ cycles
Standards/regulations	DIN EN 50178
Mounting position	any
Mounting	In rows with zero spacing
Dimensions	109.8 mm / 63 mm
EMC note	Class A product, see page 605

Ordering data

Description	Module width W	Type	Order No.	Pcs./ Pkt.
VARIOFACE termination board , for eight channels,				
24 V DC (incl. relays)	92.7	VIP-8RPT-24DC/1AU/DI/PLC	2903600	1
120 V AC (incl. relays)	92.7			

Ordering data

Description	Module width W	Type	Order No.	Pcs./ Pkt.
VARIOFACE termination board , for eight channels,				
120 V AC (incl. relays)	92.7	VIP-8RPT-120AC/1AU/DI/PLC	2904576	1

Controller-specific system cabling

Adapter for PLC-INTERFACE (6.2 mm)

PLC-V8/... are the VARIOFACE adapters connecting the eight slim 6.2 mm PLC-INTERFACE modules to the VARIOFACE system cabling:

- Can be plugged into the bridge shafts of eight aligned PLC-INTERFACE modules
- Freely definable configuration with relays, optocouplers, and passive feed-through terminal blocks
- With D-SUB connection as an option for universal connections

Notes:
Cross-ref. list for matching PLC-INTERFACE modules: page 548

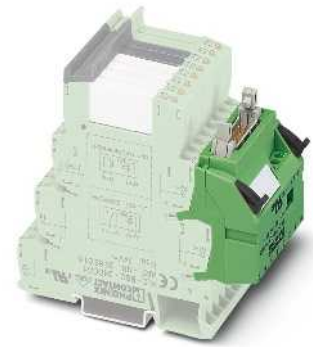

VARIOFACE adapter for 6.2 mm PLC-INTERFACE



Technical data

Maximum permissible operating voltage	30 V DC
Maximum permissible operating voltage UL / CSA	24 V / -
Maximum permissible current (per branch)	1 A (per signal path)
Maximum total current (voltage supply)	3 A
Ambient temperature (operation)	-40 °C ... 70 °C
Standards/regulations	IEC 60664 , DIN EN 50178
Connection method	Controller level Supply
Connection data solid/stranded/AWG	IDC/FLK pin strip Screw connection
Dimensions	0.2 ... 4 mm ² / 0.2 ... 2.5 mm ² / 24 - 12 100 mm / 94 mm

Ordering data

Description	No. of pos.	Module width W	Type	Order No.	Pcs./ Pkt.
V8 adapter, for 8 PLC-INTERFACE devices (6.2 mm), with IDC/FLK pin strip, for PLC system cabling, positive switching					
Output	14	49.6 mm	PLC-V8/FLK14/OUT	2295554	1
Input	14	49.6 mm	PLC-V8/FLK14/IN	2296553	1
V8 adapter, for 8 PLC-INTERFACE devices (6.2 mm), with IDC/FLK pin strip, for PLC system cabling, negative switching					
Output	14	49.6 mm	PLC-V8/FLK14/OUT/M	2304102	1
Input	14	49.6 mm	PLC-V8/FLK14/IN/M	2304115	1
V8 output adapter, for 8 PLC-INTERFACE devices (6.2 mm), with D-SUB connection					
Pin strip	15	49.6 mm	PLC-V8/D15S/OUT	2296058	1
Socket strip	15	49.6 mm	PLC-V8/D15B/OUT	2296061	1
V8 input adapter, for 8 PLC-INTERFACE devices (6.2 mm), with D-SUB connection					
Pin strip	15	49.6 mm	PLC-V8/D15S/IN	2296074	1
Socket strip	15	49.6 mm	PLC-V8/D15B/IN	2296087	1

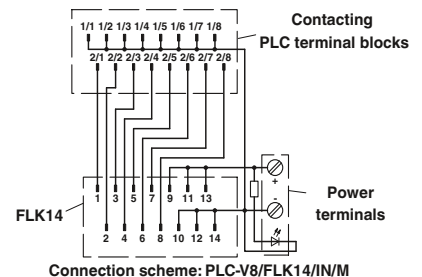
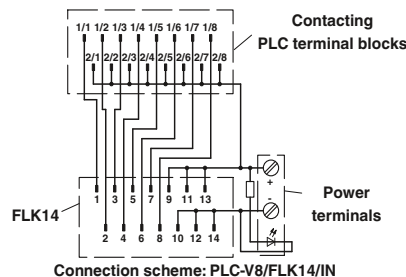
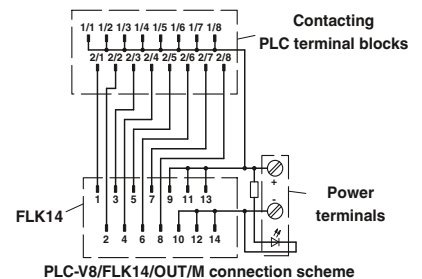
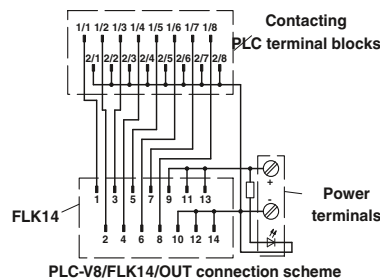

Adapter for PLC-INTERFACE (14 mm)

PLC-V8L/... are the VARIOFACE adapters connecting the eight 14 mm PLC-INTERFACE modules (2 PDT, HC, and IC types) to the system cabling:

- Can be plugged into the bridge shafts of eight aligned PLC-INTERFACE modules
- Freely definable configuration with relays or optocouplers

Notes:

Cross-ref. list for matching PLC-INTERFACE modules: page 548



VARIOFACE adapter for 14 mm PLC-INTERFACE



Technical data

Maximum permissible operating voltage	30 V DC
Maximum permissible operating voltage UL / CSA	24 V / -
Maximum permissible current (per branch)	1 A (per signal path)
Maximum total current (voltage supply)	3 A
Ambient temperature (operation)	-40 °C ... 70 °C
Mounting position	any
Standards/regulations	IEC 60664 , DIN EN 50178
Connection method	Controller level Supply
Connection data solid/stranded/AWG	IDC/FLK pin strip Screw connection
Dimensions	0.2 ... 4 mm ² / 0.2 ... 2.5 mm ² / 24 - 12 100 mm / 94 mm

Ordering data

Description	No. of pos.	Module width W
V8 adapter , for 8 PLC-INTERFACE devices (14 mm), with IDC/FLK pin strip, for PLC system cabling, positive switching	14	112.3 mm
V8 adapter , for 8 PLC-INTERFACE devices (14 mm), with IDC/FLK pin strip, for PLC system cabling, negative switching	14	112.3 mm

Type	Order No.	Pcs./Pkt.
PLC-V8L/FLK14/OUT	2299660	1
PLC-V8L/FLK14/OUT/M	2304306	1

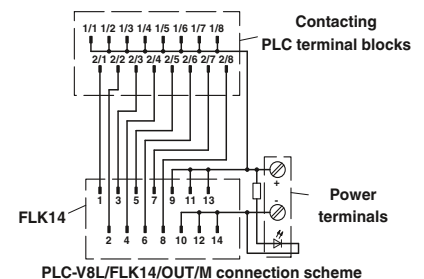
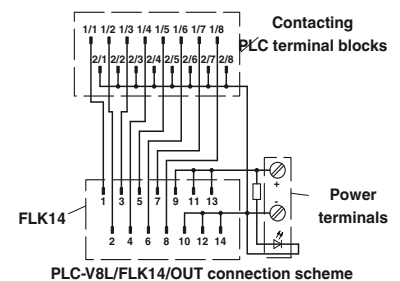

Controller-specific system cabling

Feed-through terminal blocks for PLC-INTERFACE

The VARIOFACE PLC-VT terminals are passive feed-through terminal blocks, with the same shape as the 6.2 mm slim relay and optocoupler interfaces of PLC-INTERFACE. It is thus possible to implement 8-channel interface modules for the system cabling, which can be adapted to a bit for the particular application. For individual requirements, the relay, optocoupler or the PLC-VT terminal blocks for passive signal transmission can be combined as needed.

PLC-VT PLC-VT/LA

- Can be combined with PLC-INTERFACE universal series
- Signal path with additional potential level for free assignment (two-conductor connection)
- With LED as an option

PLC-VT/ACT PLC-VT/ACT/LA

- Can be combined with PLC-INTERFACE actuator series
 - Signal path with two additional potential levels for free assignment (three-conductor connection)
 - With LED as an option
- The system connection is made via the PLC-V8 adapter.

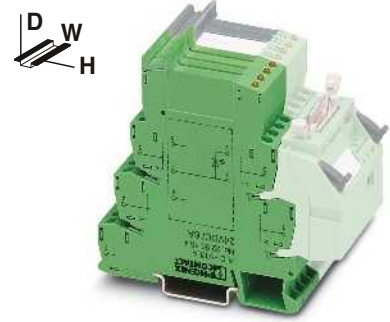

VARIOFACE feed-through terminal blocks for PLC-INTERFACE universal series



Technical data

PLC-VT, PLC-VT/ACT	PLC-VT/LA, PLC-VT/ACT/LA
250 V AC/DC	30 V DC
220 V / -	20 V / -
6 A (per signal conductor)	6 A (per signal conductor)
-40 °C ... 70 °C	-40 °C ... 70 °C
any	any
DIN EN 50178, IEC 60664	
0.2 ... 4 mm ² / 0.2 ... 2.5 mm ² / 24 - 12	
80 mm / 94 mm	

Ordering data

Description	No. of pos.	Module width W
VARIOFACE feed-through terminal block (two-conductor connection), for PLC-INTERFACE universal series		6.2 mm
VARIOFACE feed-through terminal block , as above, but with 24 V DC light indicator		6.2 mm
VARIOFACE feed-through terminal block (three-conductor connection), for PLC-INTERFACE actuator series		6.2 mm
VARIOFACE feed-through terminal block , as above, but with 24 V DC light indicator		6.2 mm

Type	Order No.	Pcs./ Pkt.
PLC-VT	2296870	10
PLC-VT/LA	2296854	10
PLC-VT/ACT	2295567	10
PLC-VT/ACT/LA	2296867	10



PLC-VT connection scheme

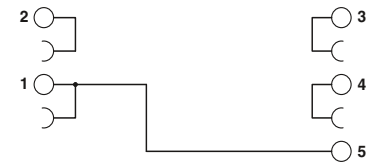

PLC-VT/ACT connection scheme

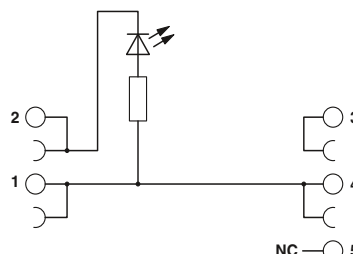

PLC-VT/LA connection scheme

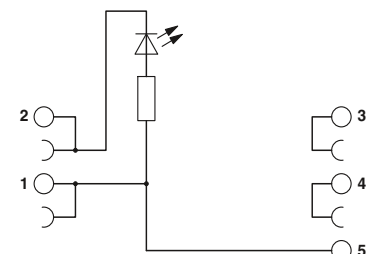

PLC-VT/ACT/LA connection scheme

Adapter for RIFLINE complete RF-1

RIF-1-V8/... VARIOFACE adapters connect the eight RIF-1 relay modules with the system cabling:

- Can be plugged into eight RIF-1 relay modules in series
- The adapter has one LED indicator and one freewheeling diode per relay

The following RIF-1 relay modules can be connected with the adapters:

With Push-in connection:

- RIF-1-RPT-LDP-24DC/1IC, Order No. **2909884***
- RIF-1-BPT/2X21, Order No. **2900931**
- RIF-1-RPT-LDP-24DC/1X21, Order No. **2903342***
- RIF-1-RPT-LDP-24DC/1X21 AU, Order No. **2903338***
- RIF-1-RPT-LDP-24DC/2X21, Order No. **2903334***
- RIF-1-RPT-LDP-24DC/2X21 AU, Order No. **2903330***
- RIF-1-RPT-LDP-24DC/1X21MS, Order No. **2905289**
- RIF-1-RPT-LDP-24DC/2X21MS, Order No. **2905291**

With screw connection:

- RIF-1-RSC-LDP-24DC/1IC, Order No. **2909885***
- RIF-1-BSC/2X21, Order No. **2900930**
- RIF-1-RSC-LDP-24DC/1X21, Order No. **2903358***
- RIF-1-RSC-LDP-24DC/1X21 AU, Order No. AU **2903354***
- RIF-1-RSC-LDP-24DC/2X21, Order No. **2903350***
- RIF-1-RSC-LDP-24DC/2X21 AU, Order No. **2903346***
- RIF-1-RSC-LDP-24DC/2X21 AU, Order No. **2903345***
- RIF-1-RSC-LDP-24DC/2X21MS, Order No. **2905550**

* If completely assembled RIF-1 relay modules are used, the indicator/interference suppression modules must be removed before installation.



VARIOFACE adapter for RIFLINE complete RIF-1



Technical data

Maximum permissible operating voltage	30 V DC
Maximum permissible operating voltage UL / CSA	24 V / -
Maximum permissible current (per branch)	1 A (per signal path)
Maximum total current (voltage supply)	3 A
Ambient temperature (operation)	-40 °C ... 60 °C
Mounting position	any
Standards/regulations	IEC 60664 , DIN EN 50178
Connection method	Controller level Supply IDC/FLK pin strip Push-in connection
Connection data solid/stranded/AWG	0.2 ... 1.5 mm ² / 0.2 ... 1.5 mm ² / 24 - 16
Dimensions	H / D 101 mm / 75 mm

Ordering data

Description	No. of pos.	Module width W	Type	Order No.	Pcs./Pkt.
V8 adapter , for eight RIF-1 relay modules, with IDC/FLK pin strip for PLC system cabling, positive switching					
	14	128 mm	RIF-1-V8/PT/FLK14/OUT	2905195	1
V8 adapter , for eight RIF-1 relay modules, with IDC/FLK pin strip for PLC system cabling, negative switching					
	14	128 mm	RIF-1-V8/PT/FLK14/OUT/M	2906992	1

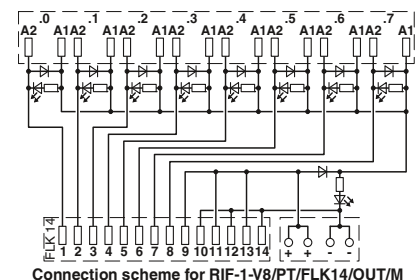
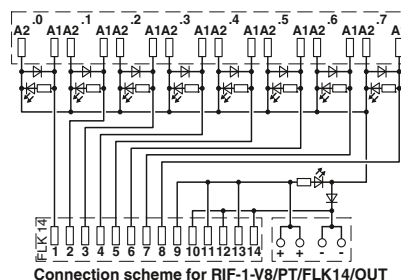

Cross-reference list for PLC-V8 adapters with matching PLC-INTERFACE modules

Series	Function	Contact	Input	Output	Page	
Universal	Relay	1 changeover contact	24 V DC	250 V AC/DC / 6 A	372	
			24 V DC	250 V AC/DC / 10 A	387	
			12 V DC	30 V AC/36 V DC / 50 mA	373	
			24 V DC	30 V AC/36 V DC / 50 mA	373	
			24 V AC/DC	30 V AC/36 V DC / 50 mA	373	
			48 V DC	30 V AC/36 V DC / 50 mA	373	
			60 V DC	30 V AC/36 V DC / 50 mA	373	
			120 V AC/DC	30 V AC/36 V DC / 50 mA	373	
			230 V AC/DC	30 V AC/36 V DC / 50 mA	373	
			120 V AC	30 V AC/36 V DC / 50 mA ¹⁾	388	
			230 V AC	30 V AC/36 V DC / 50 mA ¹⁾	388	
			1 changeover contact with manual operation	24 V DC	250 V AC/DC / 6 A	373
	12 V DC	30 V AC/36 V DC / 50 mA		373		
	24 V DC	30 V AC/36 V DC / 50 mA		373		
	24 V AC/DC	30 V AC/36 V DC / 50 mA		373		
	120 V AC/DC	30 V AC/36 V DC / 50 mA		373		
	230 V AC/DC	30 V AC/36 V DC / 50 mA		373		
	2 changeover contacts	24 V DC	250 V AC/DC / 6 A	374		
		24 V DC	30 V AC/DC / 50 mA	375		
	Relay switch	1 N/O contact	24 V AC/DC	250 V AC/DC / 6 A	404	
24 V AC/DC			250 V AC/DC / 6 A	404		
Optocoupler	1 N/O contact, electronic	24 V DC	24 V DC / 3 A	377		
		24 V DC	24 V DC / 10 A	407		
		24 V DC	250 V AC / 0.75 A	377		
		24 V DC	300 V DC / 1 A	406		
		24 V DC	48 V DC / 100 mA	376		
		48 V DC	48 V DC / 100 mA	376		
		60 V DC	48 V DC / 100 mA	376		
		120 V AC/DC	48 V DC / 100 mA	376		
		230 V AC/DC	48 V DC / 100 mA	376		
		NAMUR	24 V DC / 50 mA	420		
		120 V AC	48 V DC / 100 mA ²⁾	388		
		230 V AC	48 V DC / 100 mA ²⁾	388		
		1 changeover contact, electronic	24 V DC	48 V DC / 0.5 A	407	
	Feed-through	–	250 V AC/DC	250 V AC/DC	546	
24 V DC			24 V DC	546		
Actuator	Relay	1 N/O contact	24 V DC	250 V AC/DC / 6 A	378	
			24 V DC	250 V AC/DC / 10 A (80 A, 20 ms)	386	
		1 N/O contact with manual operation	24 V DC	250 V AC/DC / 6 A	379	
			2 N/O contacts	24 V DC	250 V AC/DC / 6 A	379
	Optocoupler	1 N/O contact, electronic	24 V DC	24 V DC / 3 A	380	
			24 V DC	24 V DC / 5 A	382	
			24 V DC	250 V AC / 0.75 A	381	
			24 V DC	250 V AC / 2 A	382	
Feed-through	–	250 V AC/DC	250 V AC/DC	546		
		24 V DC	24 V DC	546		
Sensor ⁴⁾	Relay	1 N/O contact	24 V DC	30 V AC/36 V DC / 50 mA	384	
			120 V AC/DC	30 V AC/36 V DC / 50 mA	384	
			230 V AC/DC	30 V AC/36 V DC / 50 mA	384	
			120 V AC	30 V AC/36 V DC / 50 mA ¹⁾	389	
			230 V AC	30 V AC/36 V DC / 50 mA ¹⁾	389	
			24 V DC	30 V AC/36 V DC / 50 mA	385	
	1 N/O contact with manual operation	120 V AC/DC	30 V AC/36 V DC / 50 mA	385		
		230 V AC/DC	30 V AC/36 V DC / 50 mA	385		
		Optocoupler	1 N/O contact, electronic	24 V DC	48 V DC / 100 mA	385
				120 V AC/DC	48 V DC / 100 mA	385
230 V AC/DC	48 V DC / 100 mA			385		
120 V AC	48 V DC / 100 mA ²⁾			389		
230 V AC	48 V DC / 100 mA ²⁾	389				

1) Plug-in miniature relay insert: REL-MR-60DC/21AU, [2961134](#)

2) Plug-in solid-state relay insert: OPT-60DC/48DC/100, [2966621](#)

3) PLC-...SO46 is supplied as a basic terminal block with filter, but without relay or solid-state relay.

4) Cannot be mixed with the universal series (within a byte)



Push-in connection



Screw connection

	Order No.		Order No.	PLC-V8...OUT(M)	PLC-V8...IN(M)	PLC-V8L...OUT
PLC-RPT-24DC/21	2900299	PLC-RSC-24DC/21	2966171	X		
PLC-RPT-24DC/21HC	2900291	PLC-RSC-24DC/21HC	2967620			X
PLC-RPT-12DC/21AU	2900317	PLC-RSC-12DC/21AU	2966919		X	
PLC-RPT-24DC/21AU	2900306	PLC-RSC-24DC/21AU	2966265	X	X	
PLC-RPT-24UC/21AU	2900307	PLC-RSC-24UC/21AU	2966278	X	X	
PLC-RPT-48DC/21AU	2900308	PLC-RSC-48DC/21AU	2966126		X	
PLC-RPT-60DC/21AU	2900309	PLC-RSC-60DC/21AU	2966142		X	
PLC-RPT-120UC/21AU	2900310	PLC-RSC-120UC/21AU	2966281		X	
PLC-RPT-230UC/21AU	2900311	PLC-RSC-230UC/21AU	2966294		X	
PLC-RPT-120UC/21/SO46	2900453 ³⁾	PLC-BSC-120UC/21/SO46	2980319 ³⁾		X	
PLC-RPT-230UC/21/SO46	2900455 ³⁾	PLC-BSC-230UC/21/SO46	2980335 ³⁾		X	
PLC-RPT-24DC/21/MS	2909667	PLC-RSC-24DC/21/MS	2909649	X		
PLC-RPT-12DC/21AU/MS	2909671	PLC-RSC-12DC/21AU/MS	2909654		X	
PLC-RPT-24DC/21AU/MS	2909672	PLC-RSC-24DC/21AU/MS	2909655	X	X	
PLC-RPT-24UC/21AU/MS	2909673	PLC-RSC-24UC/21AU/MS	2909656	X	X	
PLC-RPT-120UC/21AU/MS	2909674	PLC-RSC-120UC/21AU/MS	2909657		X	
PLC-RPT-230UC/21AU/MS	2909676	PLC-RSC-230UC/21AU/MS	2909660		X	
PLC-RPT-24DC/21-21	2900330	PLC-RSC-24DC/21-21	2967060			X
PLC-RPT-24DC/21-21AU	2900338	PLC-RSC-24DC/21-21AU	2967125			X
PLC-RPT-24UC/1/S/H	2900328	PLC-RSC-24UC/1/S/H	2982236	X		
PLC-RPT-24UC/1/S/L	2900327	PLC-RSC-24UC/1/S/L	2834876	X		
PLC-OPT-24DC/24DC/2	2900364	PLC-OSC-24DC/24DC/2	2966634	X		
PLC-OPT-24DC/24DC/10/R	2900398	PLC-OSC-24DC/24DC/10/R	2982702	X		
PLC-OPT-24DC/230AC/1	2900369	PLC-OSC-24DC/230AC/1	2967840	X		
PLC-OPT-24DC/300DC/1	2900383	PLC-OSC-24DC/300DC/1	2980678	X		
PLC-OPT-24DC/48DC/100	2900352	PLC-OSC-24DC/48DC/100	2966728	X	X	
PLC-OPT-48DC/48DC/100	2900353	PLC-OSC-48DC/48DC/100	2966993		X	
PLC-OPT-60DC/48DC/100	2900354	PLC-OSC-60DC/48DC/100	2967455		X	
PLC-OPT-120UC/48DC/100	2900355	PLC-OSC-120UC/48DC/100	2966744		X	
PLC-OPT-230UC/48DC/100	2900356	PLC-OSC-230UC/48DC/100	2966757		X	
PLC-PT-EIK 1-SVN 24P/P	2900397	PLC-SC-EIK 1-SVN 24P/P	2982663		X	
PLC-BPT-120UC/21/SO46	2900453 ³⁾	PLC-BSC-120UC/21/SO46	2980319 ³⁾		X	
PLC-BPT-230UC/21/SO46	2900455 ³⁾	PLC-BSC-230UC/21/SO46	2980335 ³⁾		X	
PLC-OPT-24DC/48DC/500/W	2900378	PLC-OSC-24DC/48DC/500/W	2980636	X		
-		PLC-VT	2296870	X	X	
-		PLC-VT/LA	2296854	X	X	
PLC-RPT-24DC/1/ACT	2900312	PLC-RSC-24DC/1/ACT	2966210	X		
PLC-RPT-24DC/11C/ACT	2900298	PLC-RSC-24DC/11C/ACT	2967604			X
PLC-RPT-24DC/1/MS/ACT	2909677	PLC-RSC-24DC/1/MS/ACT	2909661	X		
-		PLC-RSC-24DC/1-1/ACT	2967109			X
PLC-OPT-24DC/24DC/2/ACT	2900376	PLC-OSC-24DC/24DC/2/ACT	2966676	X		
-		PLC-OSC-24DC/24DC/5/ACT	2982786			X
-		PLC-OSC-24DC/230AC/1/ACT	2967947	X		
-		PLC-OSC-24DC/230AC/2/ACT	2982760			X
-		PLC-VT/AKT	2295567	X		
-		PLC-VT/AKT/LA	2296867	X		
PLC-RPT-24DC/1AU/SEN	2900313	PLC-RSC-24DC/1AU/SEN	2966317		X	
PLC-RPT-120UC/1AU/SEN	2900314	PLC-RSC-120UC/1AU/SEN	2966320		X	
PLC-RPT-230UC/1AU/SEN	2900315	PLC-RSC-230UC/1AU/SEN	2966333		X	
PLC-BPT-120UC/1/SEN/SO46	2900456 ³⁾	PLC-BSC-120UC/1/SEN/SO46	2980322 ³⁾		X	
PLC-BPT-230UC/1/SEN/SO46	2900457 ³⁾	PLC-BSC-230UC/1/SEN/SO46	2980348 ³⁾		X	
PLC-RPT-24DC/1AU/MS/SEN	2909678	PLC-RSC-24DC/1AU/MS/SEN	2909663			X
PLC-RPT-120UC/1AU/MS/SEN	2909679	PLC-RSC-120UC/1AU/MS/SEN	2909664			X
PLC-RPT-230UC/1AU/MS/SEN	2909680	PLC-RSC-230UC/1AU/MS/SEN	2909665			X
PLC-OPT-24DC/48DC/100/SEN	2900358	PLC-OSC-24DC/48DC/100/SEN	2966773		X	
PLC-OPT-120UC/48DC/100/SEN	2900359	PLC-OSC-120UC/48DC/100/SEN	2966799		X	
PLC-OPT-230UC/48DC/100/SEN	2900361	PLC-OSC-230UC/48DC/100/SEN	2966809		X	
PLC-BPT-120UC/1/SEN/SO46	2900456 ³⁾	PLC-BSC-120UC/1/SEN/SO46	2980322 ³⁾		X	
PLC-BPT-230UC/1/SEN/SO46	2900457 ³⁾	PLC-BSC-230UC/1/SEN/SO46	2980348 ³⁾		X	

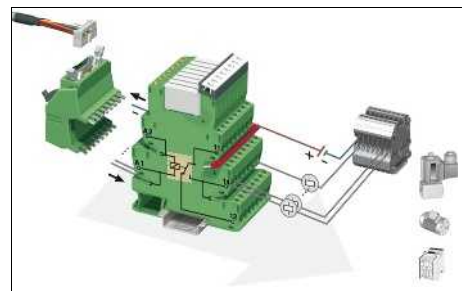

PLC universal series

The universal series can be used as an input or output interface. Each product consists of a basic terminal block with a plug-in miniature relay (changeover contact) or a plug-in solid-state relay.

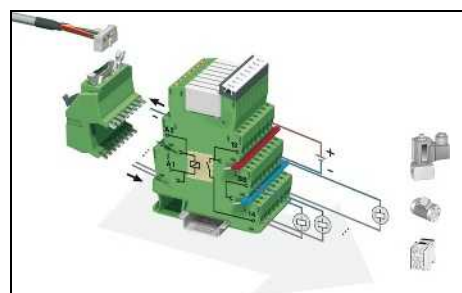

PLC actuator series

When used as an interface between the PLC and actuators, such as motors, contactors or solenoid valves, only one N/O contact function is normally required. The PLC...ACT output interface is used here. All actuator connections, including the load return line, are connected directly. This eliminates the need for additional output terminal blocks.

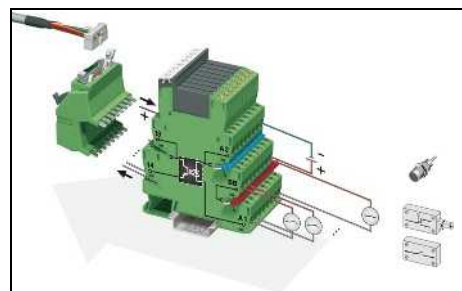

PLC sensor series

When used as an interface between the PLC and sensors, such as proximity switches, limit switches or auxiliary contacts, often only one N/O contact function is required. The PLC...SEN input interface is used here. All sensor connections, including the supply voltage for the sensors and switches, are connected directly. This eliminates the need for additional terminal blocks.

System cabling for controllers

Controller-specific system cabling

System cable with IDC/FLK socket strips

- 1:1 connection
- 14 and 50-pos.
- Connectors as per IEC 60603-13
- Unshielded
- Shielded
- Halogen-free, see page 587
- Special lengths, see page 591



Unshielded



Shield connection at one end



Applied for: cUL / UL

Technical data

Maximum permissible operating voltage	< 50 V AC / 60 V DC
Maximum permissible operating voltage UL / CSA	125 V / -
Maximum permissible current carrying capacity per path	1 A
Maximum conductor resistance	0.16 Ω/m
Ambient temperature (operation)	-20 °C ... 50 °C
Shield	-
Assembly	Insulation displacement, IEC 60352-4/DIN EN 60352-4
Conductor cross section	AWG 26 / 0.14 mm ²
Conductor structure: stranded wires / material	7 / Cu tin-plated
Outside diameter	14-pos. 6.4 mm 50-pos. 10.3 mm

Technical data

Maximum permissible operating voltage	< 50 V AC / 60 V DC
Maximum permissible operating voltage UL / CSA	125 V / -
Maximum permissible current carrying capacity per path	1 A
Maximum conductor resistance	0.16 Ω/m
Ambient temperature (operation)	-20 °C ... 50 °C
Shield	Tinned copper-braided shield, approx. 85% covering
Assembly	Insulation displacement, IEC 60352-4/DIN EN 60352-4
Conductor cross section	AWG 26 / 0.14 mm ²
Conductor structure: stranded wires / material	7 / Cu tin-plated
Outside diameter	6.7 mm 11 mm

Ordering data

Description	No. of pos.	Cable length	Type	Order No.	Pcs./ Pkt.
Assembled round cable, with two 14-pos. IDC/FLK socket strips in fixed lengths for transfer of 8 channels					
	14	0.3 m	FLK 14/EZ-DR/ 30/KONFEK	2295729	5
	14	0.5 m	FLK 14/EZ-DR/ 50/KONFEK	2288901	5
	14	1 m	FLK 14/EZ-DR/ 100/KONFEK	2288914	1
	14	1.5 m	FLK 14/EZ-DR/ 150/KONFEK	2288927	1
	14	2 m	FLK 14/EZ-DR/ 200/KONFEK	2288930	1
	14	2.5 m	FLK 14/EZ-DR/ 250/KONFEK	2288943	1
	14	3 m	FLK 14/EZ-DR/ 300/KONFEK	2288956	1
	14	3.5 m	FLK 14/EZ-DR/ 350/KONFEK	2288969	1
	14	4 m	FLK 14/EZ-DR/ 400/KONFEK	2288972	1
	14	4.5 m	FLK 14/EZ-DR/ 450/KONFEK	2290847	1
	14	5 m	FLK 14/EZ-DR/ 500/KONFEK	2290834	1
	14	5.5 m	FLK 14/EZ-DR/ 550/KONFEK	2290850	1
	14	6 m	FLK 14/EZ-DR/ 600/KONFEK	2290863	1
	14	8 m	FLK 14/EZ-DR/ 800/KONFEK	2299563	1
	14	10 m	FLK 14/EZ-DR/1000/KONFEK	2299576	1
Assembled round cable, with two 50-pos. IDC/FLK socket strips in fixed lengths for transfer of 32 channels					
	50	0.5 m	FLK 50/EZ-DR/ 50/KONFEK	2289065	5
	50	1 m	FLK 50/EZ-DR/ 100/KONFEK	2289078	1
	50	1.5 m	FLK 50/EZ-DR/ 150/KONFEK	2289081	1
	50	2 m	FLK 50/EZ-DR/ 200/KONFEK	2289094	1
	50	2.5 m	FLK 50/EZ-DR/ 250/KONFEK	2289104	1
	50	3 m	FLK 50/EZ-DR/ 300/KONFEK	2289117	1
	50	3.5 m	FLK 50/EZ-DR/ 350/KONFEK	2289120	1
	50	4 m	FLK 50/EZ-DR/ 400/KONFEK	2289133	1
	50	4.5 m	FLK 50/EZ-DR/ 450/KONFEK	2289573	1
	50	5 m	FLK 50/EZ-DR/ 500/KONFEK	2289586	1
	50	5.5 m	FLK 50/EZ-DR/ 550/KONFEK	2289599	1
	50	6 m	FLK 50/EZ-DR/ 600/KONFEK	2289609	1
	50	6.5 m	FLK 50/EZ-DR/ 650/KONFEK	2289612	1
	50	7 m	FLK 50/EZ-DR/ 700/KONFEK	2289625	1
	50	7.5 m	FLK 50/EZ-DR/ 750/KONFEK	2289638	1
	50	8 m	FLK 50/EZ-DR/ 800/KONFEK	2289641	1
	50	8.5 m	FLK 50/EZ-DR/ 850/KONFEK	2289654	1
	50	9 m	FLK 50/EZ-DR/ 900/KONFEK	2289667	1
	50	9.5 m	FLK 50/EZ-DR/ 950/KONFEK	2289670	1
	50	10 m	FLK 50/EZ-DR/1000/KONFEK	2289683	1

Ordering data

Type	Order No.	Pcs./ Pkt.
FLK 14/EZ-DR/ 50/KONFEK/S	2296977	1
FLK 14/EZ-DR/ 100/KONFEK/S	2296980	1
FLK 14/EZ-DR/ 150/KONFEK/S	2296993	1
FLK 14/EZ-DR/ 200/KONFEK/S	2297002	1
FLK 14/EZ-DR/ 300/KONFEK/S	2299013	1
FLK 14/EZ-DR/ 400/KONFEK/S	2299026	1
FLK 14/EZ-DR/ 600/KONFEK/S	2299039	1
FLK 14/EZ-DR/ 800/KONFEK/S	2299042	1
FLK 14/EZ-DR/1000/KONFEK/S	2299055	1
FLK 50/EZ-DR/ 50/KONFEK/S	2299097	1
FLK 50/EZ-DR/ 100/KONFEK/S	2299107	1
FLK 50/EZ-DR/ 150/KONFEK/S	2299110	1
FLK 50/EZ-DR/ 200/KONFEK/S	2299123	1
FLK 50/EZ-DR/ 300/KONFEK/S	2299136	1
FLK 50/EZ-DR/ 400/KONFEK/S	2299149	1
FLK 50/EZ-DR/ 600/KONFEK/S	2299152	1
FLK 50/EZ-DR/ 800/KONFEK/S	2299165	1
FLK 50/EZ-DR/1000/KONFEK/S	2299178	1

Splitting cable with IDC/FLK socket strips

- Splitting 32 channels into 4 x 8 channels
- 50-pos. connector at one end
- 4 x 14-pos. connector at one end
- Connectors as per IEC 60603-13
- Unshielded
- Shielded
- Special lengths



Splitting cable unshielded
50 positions to 4 x 14



Splitting cable shielded
50 positions to 4 x 14



Technical data

Maximum permissible operating voltage
Maximum permissible operating voltage UL / CSA
Maximum permissible current carrying capacity per path

< 50 V AC / 60 V DC
125 V / -
1 A

Maximum conductor resistance
Ambient temperature (operation)
Shield

0.16 Ω/m
-20 °C ... 50 °C
-

Assembly

Insulation displacement, IEC 60352-4/DIN EN 60352-4

Conductor cross section
Conductor structure: stranded wires / material
Number of plugs on the module side
Outside diameter

AWG 26 / 0.14 mm²
7 / Cu tin-plated
4

50-pos. 6.3 mm

Ordering data

Description	No. of pos.	Cable length
Assembled round cable , with a 50-pos. IDC/FLK socket strip and four 14-pos. IDC/FLK socket strips, for splitting 32 channels into 4 x 8 channels.		
	50	0.5 m
	50	1 m
	50	1.5 m
	50	2 m
	50	2.5 m
	50	3 m
	50	4 m
	50	6 m
	50	8 m
	50	10 m
Assembled round cable , as above, but in variable lengths		
	50	
Assembled round cable , as above, but shielded and in variable lengths		
	50	

Type	Order No.	Pcs./ Pkt.
FLK 50/4X14/EZ-DR/ 50/KONFEK	2296689	1
FLK 50/4X14/EZ-DR/ 100/KONFEK	2296692	1
FLK 50/4X14/EZ-DR/ 150/KONFEK	2296702	1
FLK 50/4X14/EZ-DR/ 200/KONFEK	2296715	1
FLK 50/4X14/EZ-DR/ 250/KONFEK	2305402	1
FLK 50/4X14/EZ-DR/ 300/KONFEK	2296728	1
FLK 50/4X14/EZ-DR/ 400/KONFEK	2296731	1
FLK 50/4X14/EZ-DR/ 600/KONFEK	2296744	1
FLK 50/4X14/EZ-DR/ 800/KONFEK	2296757	1
FLK 50/4X14/EZ-DR/1000/KONFEK	2296773	1
FLK 50-4X14-EZ-DR ...	2302405	1



Technical data

< 50 V AC / 60 V DC
125 V / -
1 A

0.16 Ω/m
-20 °C ... 50 °C
Tinned copper-braided shield, approx. 85% covering

Insulation displacement, IEC 60352-4/DIN EN 60352-4

AWG 26 / 0.14 mm²
7 / Cu tin-plated
4

6.3 mm

Ordering data

Type	Order No.	Pcs./ Pkt.
FLK 50-4X14-EZ-DR-S ...	2302447	1

Ordering example for system cable:

- Unshielded splitting cable 12.75 m long

Quantity	Order No.	Length [m] ¹⁾
1	2302405	12.75

¹⁾ min. 0.30 m

- Shielded splitting cable 11.00 m long

Quantity	Order No.	Length [m] ¹⁾
1	2302447	11.00

¹⁾ min. 0.30 m

System cabling for controllers

VIP I/O-Marshalling universal platform

VIP I/O-Marshalling base, D-SUB

VIP base element for use with IOA... plugs.

- Up to 8 channels per base
- D-SUB 25 connection to controller
- 4 connections per channel
- Multiple shield options



new

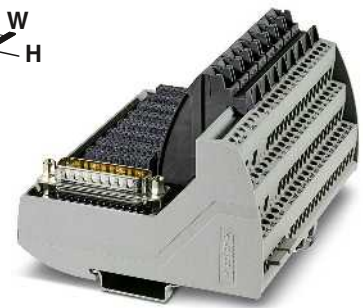

8-channel base with screw connection

Technical data

Maximum permissible operating voltage	125 V
Maximum permissible current (per branch)	3 A (field signal)
Maximum total current (voltage supply)	15 A (per module)
Ambient temperature (operation)	-40 °C ... 70 °C
Mounting position	As desired on 35 mm DIN rail in acc. with EN 60715
Standards/regulations	IEC 60664 , DIN EN 50178
Connection method	Field level Controller level Screw connection
Connection data solid/stranded/AWG	D-SUB pin strip 0.2 ... 4 mm ² / 0.2 ... 2.5 mm ² / 24 - 12
Dimensions	H / D 102.7 mm / 72.2 mm

Ordering data

Description	No. of pos.	Module width W	Type	Order No.	Pcs./ Pkt.
Base element with D-SUB 25					
- Marked 1 to 8	8	118.1 mm	VIP/S/D25M/BASE 1-8/L/C/EX	2906595	1

VIP I/O-Marshalling base, removable plugs

- VIP base element for use with IOA... plugs.
- Up to 8 channels per base
- Base elements already marked for channels 1 to 32
- 4 connections per channel
- Multiple shield options
- Color-coded COMBICON connection to controller



8-channel base with screw connection

new



8-channel base with screw connection

new

Ex:

Technical data

Maximum permissible operating voltage
Maximum permissible current (per branch)
Maximum total current (voltage supply)

125 V
3 A (field signal)
15 A (per module)

Ambient temperature (operation)
Mounting position

-40 °C ... 75 °C
As desired on 35 mm DIN rail in acc. with EN 60715

Standards/regulations
Connection method

Field level
Controller level

IEC 60664 , DIN EN 50178
Screw connection
Plug-in screw connection
0.2 ... 4 mm² / 0.2 ... 2.5 mm² / 24 - 12
102.7 mm / 72.2 mm

Connection data solid/stranded/AWG
Dimensions

H / D

Ordering data

Type	Order No.	Pcs./ Pkt.
VIP/S/MC/BASE 1-8/L/EX	2906596	1
VIP/S/MC/BASE 9-16/L/EX	2906630	1
VIP/S/MC/BASE 17-24/L/EX	2907024	1
VIP/S/MC/BASE 25-32/L/EX	2907025	1

Description	No. of pos.	Module width W
Base element with MCC		
- Marked 1 to 8	8	118.1 mm
- Marked 9 to 16	8	118.1 mm
- Marked 17 to 24	8	118.1 mm
- Marked 25 to 32	8	118.1 mm
Base element with MCC, conformally coated		
- Marked 1 to 8	8	118.1 mm
- Marked 9 to 16	8	118.1 mm
- Marked 17 to 24	8	118.1 mm
- Marked 25 to 32	8	118.1 mm

Accessories

VIP/S/BASE 3L DIVIDER	2907715	1
VIP/U/RAIL 3L DIVIDER	2908555	1

Partition plate
- Base mount
- Rail mount

Technical data

125 V
3 A (field signal)
15 A (per module)

-40 °C ... 75 °C
As desired on 35 mm DIN rail in acc. with EN 60715

IEC 60664 , DIN EN 50178
Screw connection
Plug-in screw connection
0.2 ... 4 mm² / 0.2 ... 2.5 mm² / 24 - 12
102.7 mm / 72.2 mm

Ordering data

Type	Order No.	Pcs./ Pkt.
VIP/S/MC/BASE 1-8/L/C/EX	2907186	1
VIP/S/MC/BASE 9-16/L/C/EX	2907187	1
VIP/S/MC/BASE 17-24/L/C/EX	2907209	1
VIP/S/MC/BASE 25-32/L/C/EX	2907210	1

Accessories

VIP/S/BASE 3L DIVIDER	2907715	1
VIP/U/RAIL 3L DIVIDER	2908555	1

Input/output accessory, feed-through

- IOA plug for VIP base element
- Feed-through plug for single channel
- Two-stage plug release

new



Feed-through plug

Technical data

Maximum permissible operating voltage	24 V DC
Maximum permissible current (per branch)	1 A
Ambient temperature (operation)	-40 °C ... 75 °C
Mounting position	any
Standards/regulations	IEC 60664 , DIN EN 50178
Dimensions	H / D 64.2 mm / 72.9 mm

Ordering data

Description	No. of pos.	Module width W	Type	Order No.	Pcs./ Pkt.
Feed-through plug	1	10.3 mm	IOA FEED-THRU/EX	2906598	1

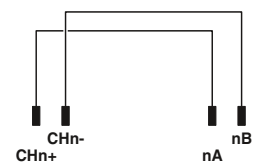

**Input/output accessory,
analog and digital**

- IOA plug for VIP base element
- Analog and digital input/output plugs for single channel
- 500 mA fuse with blown fuse indication
- Disconnect with test points
- Two-stage plug release



new

Analog protection plug with fuse



new

Digital protection plug with fuse

Technical data

Maximum permissible operating voltage
Maximum permissible current (per branch)
Ambient temperature (operation)
Mounting position
Standards/regulations
Dimensions

24 V DC
500 mA (fuse limited)
-40 °C ... 75 °C
any
IEC 60664 , DIN EN 50178
64.2 mm / 72.9 mm

Ordering data

Description	No. of pos.	Module width W
Analog protection plug - 500 mA fuse	1	10.3 mm
Digital protection plug - 1 A fuse	1	10.3 mm

Type	Order No.	Pcs./ Pkt.
IOA AI/AO/BFI/DS/0.5A/EX	2906599	1

Technical data

24 V DC
1 A (fuse limited)
-40 °C ... 75 °C
any
IEC 60664 , DIN EN 50178
64.2 mm / 72.9 mm

Ordering data

Type	Order No.	Pcs./ Pkt.
IOA DI/DO/BFI/DS/1.0A/EX	2906600	1

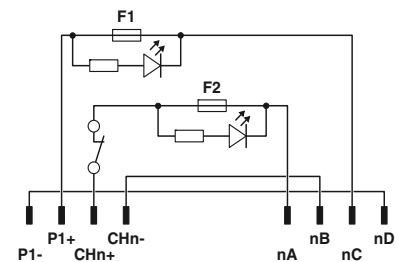
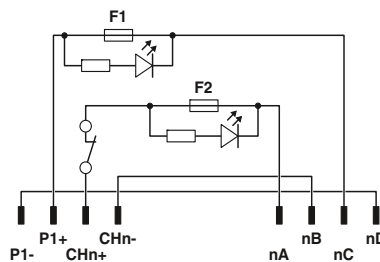

System cabling for controllers

VIP I/O-Marshalling universal platform

Input/output accessory, relay

- IOA plug for VIP base element
- Relay input and output plugs for single channel
- Fused with blown fuse indication
- Selectable N/O and N/C output contacts
- Two-stage plug release



new

Relay input plug



new

Relay output plug

Input data	
Permissible range (with reference to U_N)	0.9 - 1.1
Typical input current at U_N [mA]	7
Typical response time at U_N [ms]	5
Typical release time at U_N [ms]	8
Input protection:	Yellow LED, polarity protection diode, damping diode
Output data	
Contact type	1 N/O contact
Contact material	AgSnO, hard gold-plated
Max. switching voltage	24 V DC
Minimum switching voltage	100 mV (at 10 mA)
Limiting continuous current	50 mA
Minimum switching current	1 mA (at 24 V)
General data	
Ambient temperature (operation)	-40 °C ... 70 °C
Nominal operating mode	100% operating factor
Mechanical service life	2 x 10 ⁷ cycles
Standards/regulations	IEC 60664 , DIN EN 50178
Dimensions	10.3 mm / 64.2 mm / 72.9 mm

Technical data		
	①	②
Permissible range (with reference to U_N)	0.9 - 1.1	0.9 - 1.1
Typical input current at U_N [mA]	7	3
Typical response time at U_N [ms]	5	3
Typical release time at U_N [ms]	8	4
Input protection:	Yellow LED, polarity protection diode, damping diode	
Contact type	1 N/O contact	1 N/O contact
Contact material	AgSnO, hard gold-plated	AgSnO, hard gold-plated
Max. switching voltage	24 V DC	36 V DC
Minimum switching voltage	100 mV (at 10 mA)	-
Limiting continuous current	50 mA	50 mA
Minimum switching current	1 mA (at 24 V)	1 mA (at 24 V)
Ambient temperature (operation)	-40 °C ... 70 °C	
Nominal operating mode	100% operating factor	
Mechanical service life	2 x 10 ⁷ cycles	
Standards/regulations	IEC 60664 , DIN EN 50178	
Dimensions	10.3 mm / 64.2 mm / 72.9 mm	

Technical data		
	①	②
Permissible range (with reference to U_N)	0.9 - 1.1	0.9 - 1.1
Typical input current at U_N [mA]	13.5	13.5
Typical response time at U_N [ms]	5	5
Typical release time at U_N [ms]	8	8
Input protection:	Yellow LED, polarity protection diode, damping diode	
Contact type	1 PDT	1 PDT
Contact material	AgSnO	AgSnO
Max. switching voltage	36 V DC	120 V AC / 125 V DC
Minimum switching voltage	5 V (at 100 mA)	-
Limiting continuous current	3 A (fuse limited)	3 A (fuse limited)
Minimum switching current	10 mA (at 12 V)	10 mA (at 12 V)
Ambient temperature (operation)	-40 °C ... 70 °C	
Nominal operating mode	100% operating factor	
Mechanical service life	2 x 10 ⁷ cycles	
Standards/regulations	IEC 60664 , DIN EN 50178	
Dimensions	10.3 mm / 64.2 mm / 72.9 mm	

Description	Input voltage U_N
Digital relay input plug	① 24 V DC
	② 120 V AC/DC
Digital relay output plug	① 24 V DC
	② 24 V DC

Ordering data		
Type	Order No.	Pcs./ Pkt.
IOA REL 24V DI/BFI/1.0A/EX	2910155	10
IOA REL 120V DI/1.0A/EX	2910157	10

Ordering data		
Type	Order No.	Pcs./ Pkt.
IOA REL 24V DO/BFI/3.0A/EX	2910153	10
IOA REL 120V DO/BFI/3.0A/EX	2910154	10

IOA REL 24V DI/BFI/1.0A/EX connection scheme

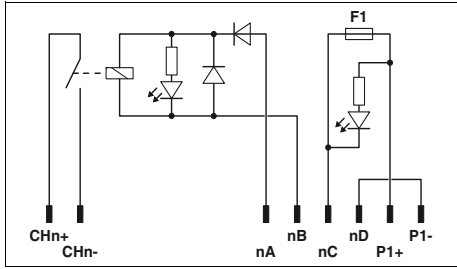

IOA REL 120V DI/1.0A/EX connection scheme

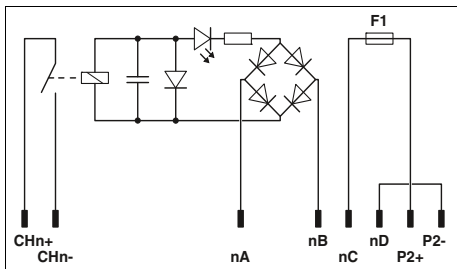

IOA REL 24V DO/BFI/3.0A/EX connection scheme

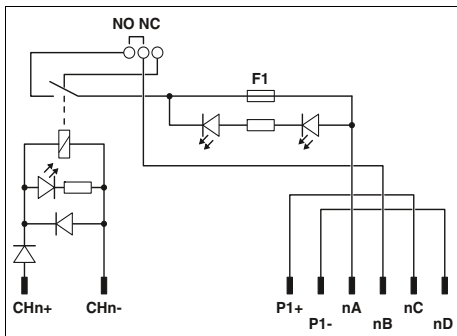

IOA REL 120V DO/BFI/3.0A/EX connection scheme

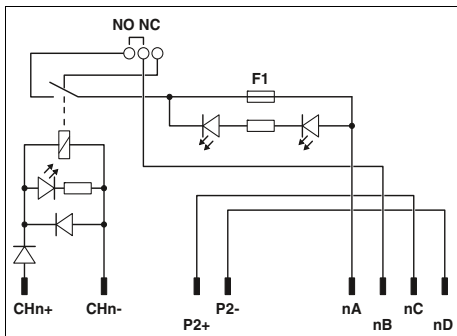



Intermediate adapter for SIMATIC® S5 to SIMATIC® S7-400

The S5 connector is plugged directly into the I/O card using the intermediate adapter. A new S7-400 is installed in place of the S5. The existing field wiring is retained.



Conversion adapter from SIMATIC® S5 to SIMATIC® S7-300

Using the adapters, the signals of the S5 front adapter are converted to a 50-pos. strip. The signals are routed to the S7-300 I/O module via a system cable and front adapter.



Startup adapter for test purposes

The universal startup adapters extend all signals of the existing S5 wiring. The open cable end can be connected to different controllers such as S7-400 or S7-300.

i Your web code: **#0007**

Simply enter “#0007” into the search field on our website.

Siemens SIMATIC® S7-300 adapter for conversion from S5-135/155 to S7-300

S5-S7 adapters connect the S5-135 front adapters wired with individual wires to the I/O modules of the S7.

With the aid of the FLKM S135/S7/FLK50 converter module, the signals of the S5-135 front adapter can be converted to a 50-pos. strip. A FLK 50/EZ-DR/.../KONFEK 50-pos. system cable and a front adapter for S7-300 (FLKM 50-PA-S300) connect the signals to the I/O module.

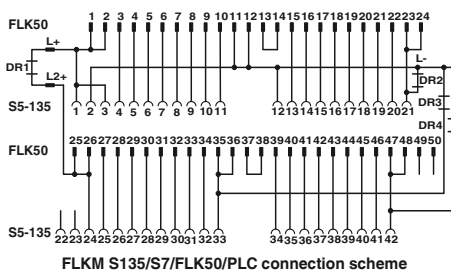

Maximum permissible operating voltage
 Maximum permissible current
 Ambient temperature (operation)
 Ambient temperature (storage/transport)
 Mounting position
 Standards/regulations

60 V DC
 1 A (per path)
 -20 °C ... 50 °C
 -20 °C ... 70 °C
 any
 IEC 60664 / DIN EN 50178

Notes:
 Due to the geometry, it is not possible to couple any molded FLK connectors (e.g., VIP-PA...S7).

Description
Digital IN or OUT 24 V DC from S5-135 to S7-300
IN 6ES5 420-4UA14 to 6ES7 321-1BL00-0AA0 6ES5 430-4UA14 to 6ES7 321-1BL00-0AA0
OUT 6ES5 441-4UA14 to 6ES7 322-1BL00-0AA0 6ES5 451-4UA14 to 6ES7 322-1BL00-0AA0

Converter for SIMATIC® S5-135 to 50-pos. FLK strip

Technical data



Ordering data		
Type	Order No.	Pcs./Pkt.
FLKM S135/S7/FLK50/PLC	2314736	1

Startup adapter for extending the existing S5-135/155 field wiring

All signals of the existing S5-135 wiring 3 or 5 are extended with the help of the universal startup adapters. The open cable end can be connected to various controllers such as S7-400 or S7-300. Thus, the existing field wiring of S5-135 can communicate with the new controller for test purposes. Since the new control unit is temporarily arranged before the control cabinet, the original status of the system can be restored if required.

The S5-135 is replaced once the system operates without errors with the new controller.

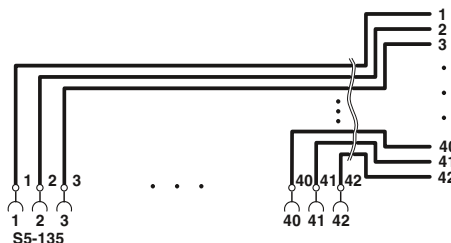

Maximum permissible operating voltage
 Maximum permissible current
 Ambient temperature (operation)
 Ambient temperature (storage/transport)
 Mounting position
 Standards/regulations

250 V AC/DC
 6 A (per path)
 -20 °C ... 50 °C
 -20 °C ... 80 °C
 any
 IEC 60664 / DIN EN 50178



Startup adapter for S5-135/155 field wiring

Technical data

Description
Connection of all S5-135 connections (1 to 42) at the open cable end
Connection of all S5-135 connections (1 to 42) without cable

Ordering data		
Type	Order No.	Pcs./Pkt.
FLKM S135/42X0,75/3,0M/OE	2315007	1
FLKM S135/42X0,75/5,0M/OE	2318017	1
FLKM S135/42XMKDSN	2901603	1

Siemens SIMATIC® S7-400 adapter for conversion from S5-135/155 to S7-400

The FLKM S135/... adapters directly connect an S5 connector wired with single wires to the S7-400 basic card.

The S5 connector is plugged directly into an S7-400 I/O card with the aid of the FLKM S135/... intermediate adapter.

A new S7-400 is installed in place of the S5. The existing field wiring is retained.

Note:

The LEDs of the S7-400 module are hidden.



Adapter for digital input modules

		Technical data		
		...SO120, ...S400, ...SO122	...SO121	
Maximum permissible operating voltage		60 V DC	60 V DC	
Maximum permissible current		4 A (per path) 4 A (per connection, supply via separate power supply)	2 A (per path) 2 A (during supply via separate power supply)	
Ambient temperature (operation)		-20 °C ... 50 °C	-20 °C ... 50 °C	
Connection method	Field level	SIEMENS S5-135 U pin strip	SIEMENS S5-135 U pin strip	
Standards/regulations		IEC 60664 / DIN EN 50178	IEC 60664 / DIN EN 50178	
		Ordering data		
Description	Module width W	Type	Order No.	Pcs./Pkt.
Digital IN 24 V DC				
6ES5 420-4UA14 on 6ES7 421-1BL01-0AA0		FLKM S135/S400/SO120	2301723	1
6ES5 430-4UA14 on 6ES7 421-1BL01-0AA0		FLKM S135/S400/SO121	2301736	1
6ES5 431-4UA12 to 6ES7 421-7DH00-0AB0		FLKM S135-431-4UA/S400	2314846	1
6ES5 432-4UA12 on 6ES7 421-1BL01-0AA0		FLKM S135/S400/SO122	2301749	1
Digital OUT 24 V DC				
6ES5 441-4UA12 to 6ES7 422-1BL00-0AA0				
6ES5 451-4UA14 to 6ES7 422-1BL00-0AA0				
Digital OUT 24 V DC / 2 A				
6ES5 453-4UA12 to 6ES7 422-1HH00-0AA0				
6ES5 454-4UA14 to 6ES7 422-1BH11-0AA0				
Analog IN				
Pt 100				
6ES5 465-4UA13 to 6ES7 431-7KF10-0AB0				
Current and voltage measurement				
6ES5 465-4UA13 to 6ES7 431-0HH00-0AB0				
6ES5 465-4UA13 to 6ES7 431-7QH00-0AB0				
Current measurement				
6ES5 460-4UA13 to 6ES7 431-1KF00-0AB0				
Voltage measurement				
6ES5 460-4UA13 to 6ES7 431-1KF00-0AB0				
Analog OUT				
Current output				
6ES5 470-4UA13 to 6ES7 432-1HF00-0AB0				
6ES5 470-4UC13 to 6ES7 432-1HF00-0AB0				
Voltage output				
6ES5 470-4UA13 to 6ES7 432-1HF00-0AB0				
6ES5 470-4UB13 to 6ES7 432-1HF00-0AB0				
6ES5 470-4UC13 to 6ES7 432-1HF00-0AB0				



Adapter for digital output modules



Adapter for analog input modules



Adapter for analog output modules

Technical data
60 V DC 4 A (per path) 4 A (per connection, supply via separate power supply)
-20 °C ... 50 °C SIEMENS S5-135 U pin strip
IEC 60664 / DIN EN 50178

Technical data	Technical data
...T/S400 60 V DC 2 A (per path) 2 A (per connection, supply via separate power supply)	...UI/S400, ...I/S400, ...U/S400 60 V DC 4 A (per path) 4 A (per connection, supply via separate power supply)
-20 °C ... 50 °C SIEMENS S5-135 U pin strip	-20 °C ... 50 °C SIEMENS S5-135 U pin strip
IEC 60664 / DIN EN 50178	IEC 60664 / DIN EN 50178

Technical data
60 V DC 4 A (per path) 4 A (per connection, supply via separate power supply)
-20 °C ... 50 °C SIEMENS S5-135 U pin strip
IEC 60664 / DIN EN 50178

Ordering data		
Type	Order No.	Pcs./ Pkt.
FLKM S135/S400/SO125	2301778	1
FLKM S135/S400/SO126	2301781	1
FLKM S135/S400/SO127	2301794	1
FLKM S135-454-4UA/S400	2314859	1

Ordering data		
Type	Order No.	Pcs./ Pkt.
FLKM S135-465-4UA/T/S400	2314875	1
FLKM S135-465-4UA/UI/S400	2314888	1
FLKM S135-460-4UA/I/S400	2314613	1
FLKM S135-460-4UA/U/S400	2314862	1

Ordering data		
Type	Order No.	Pcs./ Pkt.
FLKM S135-470-4UC/I/S400	2314626	1
FLKM S135-470-4UC/U/S400	2314891	1

System cabling for controllers

Retrofit and modernization components

Siemens SIMATIC® S7-400 adapter for conversion from S5-115 to S7-400

The FLKM S115/... adapters directly connect an S5 connector wired with single wires to the S7-400 basic card.

The S5 connector is plugged directly into an S7-400 I/O card with the aid of the FLKM S115/... intermediate adapter.

A new S7-400 is installed in place of the S5. The existing field wiring is retained.

Note:

Due to the geometry, it is only possible to use every other slot. The LEDs of the S7-400 module are hidden by the S5-115 adapter.



Adapter for
SIMATIC® S5-115/S7-400

Technical data

Maximum permissible operating voltage	60 V DC
Maximum permissible current	4 A (per path) 4 A (per connection, supply via separate power supply)
Ambient temperature (operation)	-20 °C ... 50 °C
Ambient temperature (storage/transport)	-20 °C ... 70 °C
Mounting position	any
Standards/regulations	IEC 60664 / DIN EN 50178

Ordering data

Description	Type	Order No.	Pcs./Pkt.
Digital IN or OUT 24 V DC from S5-115 to S7-400			
IN 6ES5 420-7LA11 to 6ES7 421-1BL01-0AA0 6ES5 430-7LA11 to 6ES7 421-1BL01-0AA0	FLKM S115/S400/SO155	2307248	1
OUT 6ES5 441-7LA11 to 6ES7 422-1BL00-0AA0 6ES5 451-7LA11 to 6ES7 422-1BL00-0AA0			
Digital OUT 24 V DC from S5-115 to S7-400			
6ES5 454-7LA12 to 6ES7 422-1BH11-0AA0	FLKM S115-454-7LA/S400	2314901	1

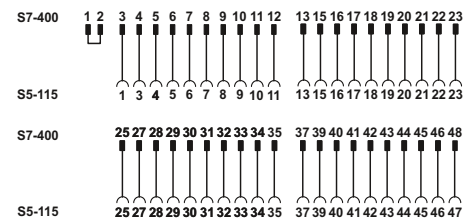

Connection scheme: FLKM S115/S400/SO155

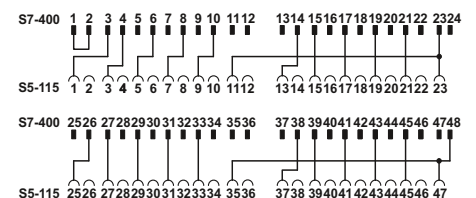

FLKM S115-454-7LA/S400 connection scheme

Siemens SIMATIC® S7-300 adapter for conversion from S5-115 to S7-300

S5-S7 adapters connect the S5-115 front adapters wired with individual wires to the I/O modules of S7-300.

With the aid of the FLKM S115/S7/FLK50/SO137 converter module, the signals of the S5-115 front adapter can be converted to a 50-pos. strip. A FLK 50/EZ-DR/.../KONFEK 50-pos. system cable and a front adapter for S7-300 (FLKM 50-PA-S300) connect the signals to the I/O module.

Notes:
Due to the geometry, it is not possible to couple any molded FLK connectors (e.g., VIP-PA...S7).

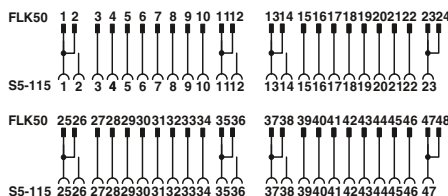

Connection scheme: FLKM S115/S7/FLK50/PLC/SO137

Maximum permissible operating voltage
Maximum permissible current
Maximum permissible total current
Ambient temperature (operation)
Ambient temperature (storage/transport)
Standards/regulations

60 V DC
1 A (per path)
2 A (per byte)
-20 °C ... 50 °C
-20 °C ... 70 °C
IEC 60664 / DIN EN 50178

Description
Digital IN or OUT 24 V DC from S5-115 through converters, system cables and front adapters to S7-300

IN
6ES5 420-7LA11 on 6ES7 321-1BL00-0AA0
6ES5 430-7LA11 on 6ES7 321-1BL00-0AA0
OUT
6ES5 441-7LA11 on 6ES7 322-1BL00-0AA0
6ES5 451-7LA11 on 6ES7 322-1BL00-0AA0

Ordering data

Type	Order No.	Pcs./Pkt.
FLKM S115/S7/FLK50/PLC/SO137	2306294	1



Converter for SIMATIC® S5-115 to 50-pos. FLK strip

Startup adapters for extending the existing S5-115 field wiring

All signals of the existing S5-115 wiring 3 or 5 are extended with the help of the universal startup adapters. The open cable end can be connected to various controllers such as S7-400 or S7-300. Thus, the existing field wiring of S5-115 can communicate with the new controller for test purposes. Since the new control unit is temporarily arranged before the control cabinet, the original status of the system can be restored if required.

The S5-115 is replaced once the system operates without errors with the new controller.

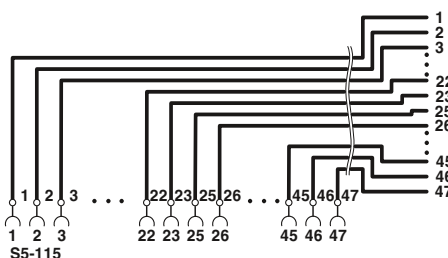

Maximum permissible operating voltage
Maximum permissible current
Ambient temperature (operation)
Ambient temperature (storage/transport)
Mounting position
Standards/regulations

250 V AC/DC
6 A (per path)
-20 °C ... 50 °C
-20 °C ... 80 °C
any
DIN EN 50178 / IEC 60664

Description
Connection of all S5-115 connections (1 to 23, 25 to 47) at the open cable end

Ordering data

Type	Order No.	Pcs./Pkt.
FLKM S115/47X0,75/3,0M/OE	2314985	1
FLKM S115/47X0,75/5,0M/OE	2314998	1



Startup adapter for S5-115 field wiring

Siemens SIMATIC® S7-300 adapter for conversion from S5-95U to S7-300

S5-S7 adapters connect the S5-95U front adapters wired with individual wires to the I/O modules of the S7-300.

With the aid of the UM-S95U/S/FLK50/PLC converter module, the signals can be converted to a 50-pos. strip. A FLK 50/EZ-DR/.../KONFEK 50-pos. cable and the front adapter for SIMATIC® S7-300 (FLKM 50-PA-S300) establish a connection to the I/O module.

Notes:

Due to the geometry, it is not possible to couple any molded FLK connectors (e.g., VIP-PA...S7).



new

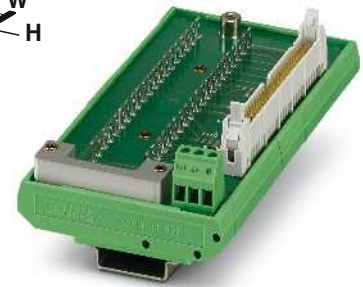

Converter for SIMATIC® S5-95U to 50-pos. IDC/FLK pin strip

Technical data

Maximum permissible operating voltage	30 V DC
Maximum permissible current (per branch)	1 A
Ambient temperature (operation)	-20 °C ... 50 °C
Mounting position	any
Standards/regulations	DIN EN 50178
Connection method	Field level Slip-on connection
Dimensions	Controller level IDC/FLK pin strip 77 mm / 49 mm H / D

Ordering data

Description	No. of pos.	Module width W	Type	Order No.	Pcs./ Pkt.
Digital 16 IN/16 OUT, 24 V DC from S5-95U/100U to S7-300 S5-100U: 6ES5 482-8MA13 to 6ES7 323-1BL00-AA0 S5-95U: 6ES5 095-8MA03 to 6ES7 323-1BL00-AA0		135 mm	UM-S95U/S7/FLK50/PLC	2907030	1



Universal modules

VIP – VARIOFACE Professional modules with IDC/FLK pin strip

- 1:1 connection
 - 10 to 64-pos.
 - Screw connection
 - Metal foot
 - As per IEC 60603-13
 - With status indicator as an option
- Low and high engagement latches are supplied with all modules.

Notes:
For marking systems (e.g., "ZB 22:UNBEDRUCKT"; Order No. 0811862) and mounting material, see Catalog 3.



10 to 20 positions
with screw connection



Technical data

Maximum permissible operating voltage	60 V AC/DC
Maximum permissible operating voltage UL / CSA	125 V / 125 V
Maximum permissible current (per branch)	1 A
Ambient temperature (operation)	-20 °C ... 50 °C
Mounting position	any
Standards/regulations	IEC 60664, DIN EN 50178
Connection data solid/stranded/AWG	0.2 - 4 mm ² / 0.2 - 2.5 mm ² / 24 - 12
Dimensions	H / D 65.5 mm / 56 mm

Ordering data

Description	No. of pos.	Module width W	Type	Order No.	Pcs./ Pkt.
VARIOFACE module, with pin strip	10	34.70	VIP-2/SC/FLK10	2315010	1
	14	39.80	VIP-2/SC/FLK14	2315023	1
	16	45.00	VIP-2/SC/FLK16	2315036	1
	20	55.10	VIP-2/SC/FLK20	2315049	1
VARIOFACE module, with pin strip and light indicator	10	34.70			
	14	44.90			
	16	50.00			
	20	60.20			
VARIOFACE module, with pin strip	26	57.10			
	34	67.30			
	40	77.40			
	50	92.70			
	60	108.00			
	64	118.00			
VARIOFACE module, with pin strip and light indicator	26	57.40			
	34	67.60			
	40	77.80			
	50	93.10			
	60	113.50			
	64	118.60			

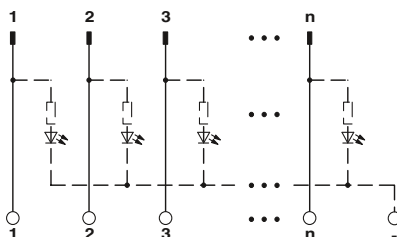



10 to 20 positions
with screw connection and light indicator



26 to 64 positions
with screw connection



26 to 64 positions
with screw connection and light indicator



Technical data
24 V DC 24 V / 24 V
1 A -20 °C ... 50 °C any IEC 60664 , DIN EN 50178 0.2 - 4 mm ² / 0.2 - 2.5 mm ² / 24 - 12 65.5 mm / 56 mm

Technical data
60 V AC/DC 125 V / 125 V
1 A -20 °C ... 50 °C any IEC 60664 , DIN EN 50178 0.2 - 4 mm ² / 0.2 - 2.5 mm ² / 24 - 12 69 mm / 62 mm

Technical data
24 V DC 24 V / 24 V
1 A -20 °C ... 50 °C any IEC 60664 , DIN EN 50178 0.2 - 4 mm ² / 0.2 - 2.5 mm ² / 24 - 12 69 mm / 62 mm

Ordering data

Ordering data

Ordering data

Type	Order No.	Pcs./ Pkt.
VIP-2/SC/FLK10/LED	2322045	1
VIP-2/SC/FLK14/LED	2322058	1
VIP-2/SC/FLK16/LED	2322061	1
VIP-2/SC/FLK20/LED	2322074	1

Type	Order No.	Pcs./ Pkt.
VIP-3/SC/FLK26	2315052	1
VIP-3/SC/FLK34	2315065	1
VIP-3/SC/FLK40	2315078	1
VIP-3/SC/FLK50	2315081	1
VIP-3/SC/FLK60	2315094	1
VIP-3/SC/FLK64	2315104	1

Type	Order No.	Pcs./ Pkt.
VIP-3/SC/FLK26/LED	2322087	1
VIP-3/SC/FLK34/LED	2322090	1
VIP-3/SC/FLK40/LED	2322100	1
VIP-3/SC/FLK50/LED	2322113	1
VIP-3/SC/FLK60/LED	2322126	1
VIP-3/SC/FLK64/LED	2322139	1

Universal modules

VIP – VARIOFACE Professional modules with IDC/FLK pin strip

- 1:1 connection
 - 10 to 64-pos.
 - Push-in connection
 - Metal foot
 - As per IEC 60603-13
 - With status indicator as an option
- Low and high engagement latches are supplied with all modules.

Notes:
For marking systems (e.g., "ZB 22:UNBEDRUCKT"; Order No. 0811862) and mounting material, see Catalog 3.



10 to 20 positions
with Push-in connection



Technical data

Maximum permissible operating voltage	60 V AC/DC
Maximum permissible operating voltage UL / CSA	125 V / 125 V
Maximum permissible current (per branch)	1 A
Ambient temperature (operation)	-20 °C ... 50 °C
Mounting position	any
Standards/regulations	IEC 60664, DIN EN 50178
Connection data solid/stranded/AWG	0.14 - 2.5 mm ² / 0.14 - 2.5 mm ² / 26 - 14
Dimensions	H / D 72.1 mm / 56 mm

Ordering data

Description	No. of pos.	Module width W	Type	Order No.	Pcs./ Pkt.
VARIOFACE module, with pin strip	10	36.80	VIP-2/PT/FLK10	2903787	1
	14	41.90	VIP-2/PT/FLK14	2903788	1
	16	46.90	VIP-2/PT/FLK16	2903789	1
	20	57.10	VIP-2/PT/FLK20	2903790	1
VARIOFACE module, with pin strip and light indicator	10	36.80			
	14	41.90			
	16	46.90			
	20	57.10			
VARIOFACE module, with pin strip	26	57.10			
	34	67.30			
	40	77.40			
	50	92.70			
	60	107.90			
	64	118.10			
VARIOFACE module, with pin strip and light indicator	26	57.10			
	34	67.30			
	40	77.40			
	50	92.70			
	60	107.90			
	64	118.10			

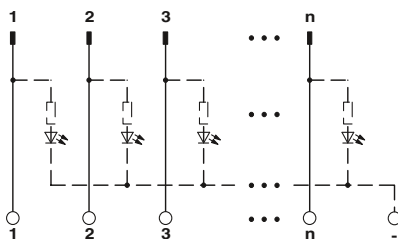



10 to 20 positions
with Push-in connection and light indicator

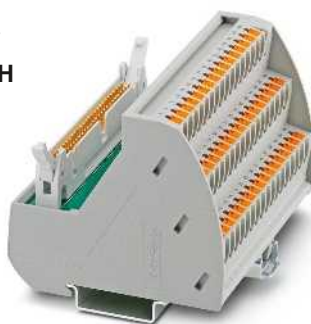

26 to 64 positions
with Push-in connection

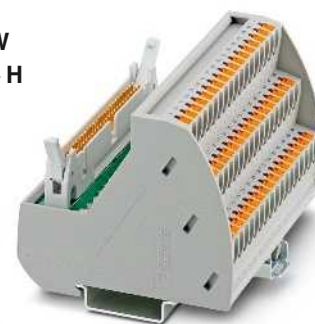

26 to 64 positions
with Push-in connection and light indicator



Technical data
24 V DC 24 V / 24 V
1 A -20 °C ... 50 °C any IEC 60664 , DIN EN 50178 0.14 - 2.5 mm ² / 0.14 - 2.5 mm ² / 26 - 14 72.1 mm / 56 mm

Technical data
60 V AC/DC 125 V / 125 V
1 A -20 °C ... 50 °C any IEC 60664 , DIN EN 50178 0.14 - 2.5 mm ² / 0.14 - 2.5 mm ² / 26 - 14 75.8 mm / 63 mm

Technical data
24 V DC 24 V / 24 V
1 A -20 °C ... 50 °C any IEC 60664 , DIN EN 50178 0.14 - 2.5 mm ² / 0.14 - 2.5 mm ² / 26 - 14 75.8 mm / 63 mm

Ordering data

Ordering data

Ordering data

Type	Order No.	Pcs./ Pkt.
VIP-2/PT/FLK10/LED	2904248	1
VIP-2/PT/FLK14/LED	2904249	1
VIP-2/PT/FLK16/LED	2904250	1
VIP-2/PT/FLK20/LED	2904251	1

Type	Order No.	Pcs./ Pkt.
VIP-3/PT/FLK26	2903791	1
VIP-3/PT/FLK34	2903792	1
VIP-3/PT/FLK40	2903793	1
VIP-3/PT/FLK50	2903794	1
VIP-3/PT/FLK60	2903795	1
VIP-3/PT/FLK64	2903796	1

Type	Order No.	Pcs./ Pkt.
VIP-3/PT/FLK26/LED	2904252	1
VIP-3/PT/FLK34/LED	2904253	1
VIP-3/PT/FLK40/LED	2904254	1
VIP-3/PT/FLK50/LED	2904255	1
VIP-3/PT/FLK60/LED	2904256	1
VIP-3/PT/FLK64/LED	2904257	1

Universal modules

VIP – VARIOFACE Professional Modules with D-SUB connectors

- 1:1 connection
 - 9 to 50-pos.
 - Screw connection
 - Metal foot
 - As per IEC 60807-2
 - With status indicator as an option
- The D-SUB-4-40 UNC threads are led on to a connecting terminal block directly.

Notes:
For marking systems (e.g., "ZB 22:UNBEDRUCKT"; Order No. 0811862) and mounting material, see Catalog 3.



9 to 15 positions with screw connection



Maximum permissible operating voltage
Maximum permissible operating voltage UL / CSA

Maximum permissible current (per branch)
Ambient temperature (operation)
Mounting position
Standards/regulations
Connection data solid/stranded/AWG
Dimensions

Technical data	
Maximum permissible operating voltage	25 V AC / 60 V DC
Maximum permissible operating voltage UL / CSA	125 V / 105 V
Maximum permissible current (per branch)	2 A
Ambient temperature (operation)	-20 °C ... 50 °C
Mounting position	any
Standards/regulations	IEC 60664, DIN EN 50178
Connection data solid/stranded/AWG	0.2 - 4 mm ² / 0.2 - 2.5 mm ² / 24 - 12
Dimensions	65.5 mm / 45.1 mm

Description	No. of pos.	Module width W
VARIOFACE module , with D-Subminiature pin strip	9	34.70
	15	45.00
VARIOFACE module , with D-Subminiature pin strip and light indicator	9	34.70
	15	50.00
VARIOFACE module , with D-Subminiature socket strip	9	34.70
	15	45.00
VARIOFACE module , with D-Subminiature socket strip and light indicator	9	34.70
	15	50.00
VARIOFACE module , with D-Subminiature pin strip	25	57.40
	37	72.70
	50	98.20
VARIOFACE module , with D-Subminiature pin strip and light indicator	25	57.40
	37	72.70
	50	98.20
VARIOFACE module , with D-Subminiature socket strip	25	57.40
	37	72.70
	50	98.20
VARIOFACE module , with D-Subminiature socket strip and light indicator	25	57.40
	37	72.70
	50	98.20

Ordering data		
Type	Order No.	Pcs./ Pkt.
VIP-2/SC/D 9SUB/M	2315117	1
	2315120	1
VIP-2/SC/D 9SUB/F	2315162	1
	2315175	1

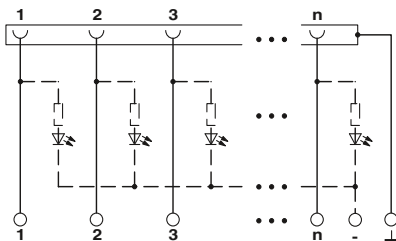



9 to 15 positions
with screw connection and light indicator

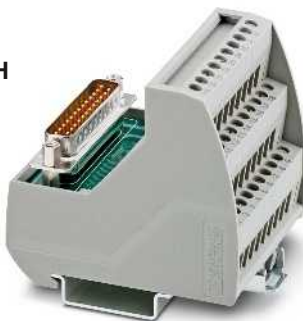

25 to 50 positions
with screw connection



25 to 50 positions
with screw connection and light indicator



Technical data
24 V DC 24 V / 24 V
2.5 A -20 °C ... 50 °C any IEC 60664 , DIN EN 50178 0.2 - 4 mm ² / 0.2 - 2.5 mm ² / 24 - 12 65.5 mm / 45.1 mm

Technical data
25 V AC / 60 V DC 125 V / 105 V
2 A -20 °C ... 50 °C any IEC 60664 , DIN EN 50178 0.2 - 4 mm ² / 0.2 - 2.5 mm ² / 24 - 12 69 mm / 62 mm

Technical data
24 V DC 24 V / 24 V
2.5 A -20 °C ... 50 °C any IEC 60664 , DIN EN 50178 0.2 - 4 mm ² / 0.2 - 2.5 mm ² / 24 - 12 69 mm / 62 mm

Ordering data		
Type	Order No.	Pcs./ Pkt.
VIP-2/SC/D 9SUB/M/LED	2322142	1
VIP-2/SC/D15SUB/M/LED	2322155	1
VIP-2/SC/D 9SUB/F/LED	2322197	1
VIP-2/SC/D15SUB/F/LED	2322207	1

Ordering data		
Type	Order No.	Pcs./ Pkt.
VIP-3/SC/D25SUB/M	2315133	1
VIP-3/SC/D37SUB/M	2315146	1
VIP-3/SC/D50SUB/M	2315159	1
VIP-3/SC/D25SUB/F	2315188	1
VIP-3/SC/D37SUB/F	2315191	1
VIP-3/SC/D50SUB/F	2315201	1

Ordering data		
Type	Order No.	Pcs./ Pkt.
VIP-3/SC/D25SUB/M/LED	2322168	1
VIP-3/SC/D37SUB/M/LED	2322171	1
VIP-3/SC/D50SUB/M/LED	2322184	1
VIP-3/SC/D25SUB/F/LED	2322210	1
VIP-3/SC/D37SUB/F/LED	2322223	1
VIP-3/SC/D50SUB/F/LED	2322236	1

Universal modules

VIP – VARIOFACE Professional Modules with D-SUB connectors

- 1:1 connection
 - 9 to 50-pos.
 - Push-in connection
 - Metal foot
 - As per IEC 60807-2
 - With status indicator as an option
- The D-SUB-4-40 UNC threads are led on to a connecting terminal block directly.

Notes:
For marking systems (e.g., "ZB 22:UNBEDRUCKT"; Order No. 0811862) and mounting material, see Catalog 3.



9 to 15 positions
with Push-in connection



Technical data

Maximum permissible operating voltage	25 V AC / 60 V DC
Maximum permissible operating voltage UL / CSA	125 V / 105 V
Maximum permissible current (per branch)	2 A
Ambient temperature (operation)	-20 °C ... 50 °C
Mounting position	any
Standards/regulations	IEC 60664, DIN EN 50178
Connection data solid/stranded/AWG	0.14 - 2.5 mm ² / 0.14 - 2.5 mm ² / 26 - 14
Dimensions	72.1 mm / 46.6 mm

Ordering data

Description	No. of pos.	Module width W	Type	Order No.	Pcs./ Pkt.
VARIOFACE module , with D-Subminiature pin strip	9	36.80	VIP-2/PT/D 9SUB/M	2903777	1
	15	46.90			
VARIOFACE module , with D-Subminiature pin strip and light indicator	9	36.80			
	15	52.00			
VARIOFACE module , with D-Subminiature socket strip	9	36.80	VIP-2/PT/D 9SUB/F	2903778	1
	15	46.90			
VARIOFACE module , with D-Subminiature socket strip and light indicator	9	36.80			
	15	52.00			
VARIOFACE module , with D-Subminiature pin strip	25	57.10			
	37	72.30			
	50	97.70			
VARIOFACE module , with D-Subminiature pin strip and light indicator	25	57.10			
	37	72.30			
	50	97.70			
VARIOFACE module , with D-Subminiature socket strip	25	57.10			
	37	72.30			
	50	97.70			
VARIOFACE module , with D-Subminiature socket strip and light indicator	25	57.10			
	37	72.30			
	50	97.70			

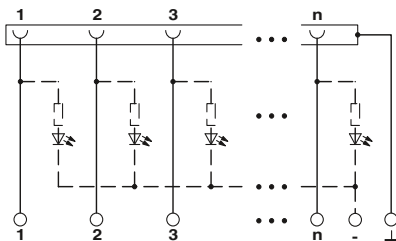



9 to 15 positions
with Push-in connection and light indicator

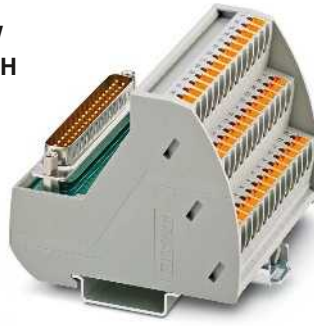

25 to 50 positions
with Push-in connection

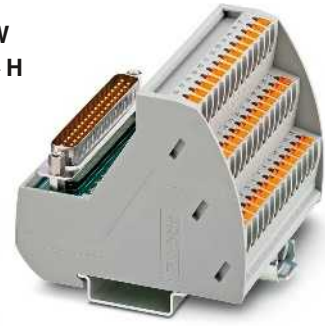

25 to 50 positions
with Push-in connection and light indicator



Technical data
24 V DC 24 V / 24 V
2 A -20 °C ... 50 °C any IEC 60664 , DIN EN 50178 0.14 - 2.5 mm ² / 0.14 - 2.5 mm ² / 26 - 14 72.1 mm / 46.6 mm

Technical data
25 V AC / 60 V DC 125 V / 105 V
2 A -20 °C ... 50 °C any IEC 60664 , DIN EN 50178 0.14 - 2.5 mm ² / 0.14 - 2.5 mm ² / 26 - 14 75.8 mm / 63 mm

Technical data
24 V DC 24 V / 24 V
2 A -20 °C ... 50 °C any IEC 60664 , DIN EN 50178 0.14 - 2.5 mm ² / 0.14 - 2.5 mm ² / 26 - 14 75.8 mm / 63 mm

Ordering data		
Type	Order No.	Pcs./ Pkt.
VIP-2/PT/D 9SUB/M/LED VIP-2/PT/D15SUB/M/LED	2904258 2904259	1 1
VIP-2/PT/D 9SUB/F/LED VIP-2/PT/D15SUB/F/LED	2904263 2904264	1 1

Ordering data		
Type	Order No.	Pcs./ Pkt.
VIP-3/PT/D25SUB/M VIP-3/PT/D37SUB/M VIP-3/PT/D50SUB/M	2903781 2903783 2903785	1 1 1
VIP-3/PT/D25SUB/F VIP-3/PT/D37SUB/F VIP-3/PT/D50SUB/F	2903782 2903784 2903786	1 1 1

Ordering data		
Type	Order No.	Pcs./ Pkt.
VIP-3/PT/D25SUB/M/LED VIP-3/PT/D37SUB/M/LED VIP-3/PT/D50SUB/M/LED	2904260 2904261 2904262	1 1 1
VIP-3/PT/D25SUB/F/LED VIP-3/PT/D37SUB/F/LED VIP-3/PT/D50SUB/F/LED	2904265 2904266 2904267	1 1 1

System cabling for controllers

Universal modules

SLIM-LINE modules for D-SUB connectors

These VARIOFACE modules connect D-SUB strips with front connection terminal blocks in accordance with IEC 60807-2/DIN 41652.

To make the ground connection, the metallic plug shell (4-40 UNC thread) makes contact with a connecting terminal block.



9 to 25 positions
with screw connection



37 to 50 positions
with screw connection

Maximum permissible operating voltage
Maximum permissible current (per branch)
Ambient temperature (operation)
Mounting position
Standards/regulations
Screw connection solid/stranded/AWG
Dimensions

D / W

ERC

Technical data

25 V AC / 60 V DC
2.5 A
-10 °C ... 50 °C
any
DIN EN 50178 , IEC 60664
0.2 ... 4 mm² / 0.2 ... 2.5 mm² / 24 - 12
45 mm / 25 mm

Ordering data

Description	No. of pos.	Module height H
VARIOFACE-SLIM-LINE module, with D-Subminiature pin strip		
	9	117.00
	15	147.00
	25	217.00
VARIOFACE-SLIM-LINE module, with D-Subminiature socket strip		
	9	117.00
	15	147.00
	25	217.00
VARIOFACE-SLIM-LINE module, with D-Subminiature pin strip		
	37	157.00
	50	187.00
VARIOFACE-SLIM-LINE module, with D-Subminiature socket strip		
	37	157.00
	50	187.00

ERC

Technical data

25 V AC / 60 V DC
2.5 A
-10 °C ... 50 °C
any
DIN EN 50178 , IEC 60664
0.2 ... 4 mm² / 0.2 ... 2.5 mm² / 24 - 12
45 mm / 45 mm

Ordering data

Type	Order No.	Pcs./ Pkt.
UM 25-D 9SUB/S/Front/Q	2959573	1
UM 25-D15SUB/S/Front/Q	2959599	1
UM 25-D25SUB/S/Front/Q	2959612	1
UM 25-D 9SUB/B/Front/Q	2959560	1
UM 25-D15SUB/B/Front/Q	2959586	1
UM 25-D25SUB/B/Front/Q	2959609	1

Type	Order No.	Pcs./ Pkt.
UM 45-D37SUB/S/Front/Q	2959638	1
UM 45-D50SUB/S/Front/Q	2959654	1
UM 45-D37SUB/B/Front/Q	2959625	1
UM 45-D50SUB/B/Front/Q	2959641	1

Feed-through modules for D-SUB connectors with screw connection

- 1:1 connection
- 9 to 50-pos.
- Screw connection
- As per IEC 60807-2
- D-SUB 4-40 UNC thread
- 9 to 37-pos.: separate ground tap
- 50-pos.: no ground tap



With D-SUB pin strip



With D-SUB socket strip

			Technical data			Technical data		
Maximum permissible operating voltage			25 V AC / 60 V DC			25 V AC / 60 V DC		
Maximum permissible operating voltage UL / CSA			125 V / -			125 V / -		
Maximum permissible current (per branch)			2.5 A			2.5 A		
Ambient temperature (operation)			-20 °C ... 50 °C			-20 °C ... 50 °C		
Mounting position			any			any		
Standards/regulations			IEC 60664 , DIN EN 50178			IEC 60664 , DIN EN 50178		
Connection data solid/stranded/AWG			0.2 - 4 mm ² / 0.2 - 2.5 mm ² / 24 - 12			0.2 - 4 mm ² / 0.2 - 2.5 mm ² / 24 - 12		
			Ordering data			Ordering data		
Description	No. of pos.	Module width W	Type	Order No.	Pcs./ Pkt.	Type	Order No.	Pcs./ Pkt.
VARIOFACE feed-through module, with D-subminiature connector	9	39.00	DFLK-D 9 SUB/S	2283870	5	DFLK-D 9 SUB/B	2287135	5
	15	39.00	DFLK-D15 SUB/S	2280297	5	DFLK-D15 SUB/B	2280307	5
	25	39.00	DFLK-D25 SUB/S	2280310	5	DFLK-D25 SUB/B	2280323	5
	37	39.00	DFLK-D37 SUB/S	2280336	5	DFLK-D37 SUB/B	2280349	5
	50	39.00	DFLK-D50 SUB/S	2291286	5	DFLK-D50 SUB/B	2287669	5

Dimensioning of the housing cutout

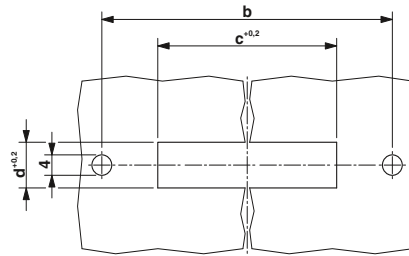

Type	a	b	c	d
DFLK-D 9 SUB/S	58.4	52.5	40.2 + 0.2	13 + 0.2
DFLK-D 15 SUB/S	58.4	52.5	40.2 + 0.2	13 + 0.2
DFLK-D 25 SUB/S	83.4	77.5	54.2 + 0.2	13 + 0.2
DFLK-D 37 SUB/S	128.4	122.5	70.6 + 0.2	13 + 0.2
DFLK-D 50 SUB/S	143.4	137.5	67.8 + 0.2	15.8 + 0.2
DFLK-D 9 SUB/B	58.4	52.5	40.2 + 0.2	13 + 0.2
DFLK-D 15 SUB/B	58.4	52.5	40.2 + 0.2	13 + 0.2
DFLK-D 25 SUB/B	83.4	77.5	54.2 + 0.2	13 + 0.2
DFLK-D 37 SUB/B	128.4	122.5	70.6 + 0.2	13 + 0.2
DFLK-D 50 SUB/B	143.4	137.5	67.8 + 0.2	15.8 + 0.2

Dimensional drawing DFLK-D...SUB

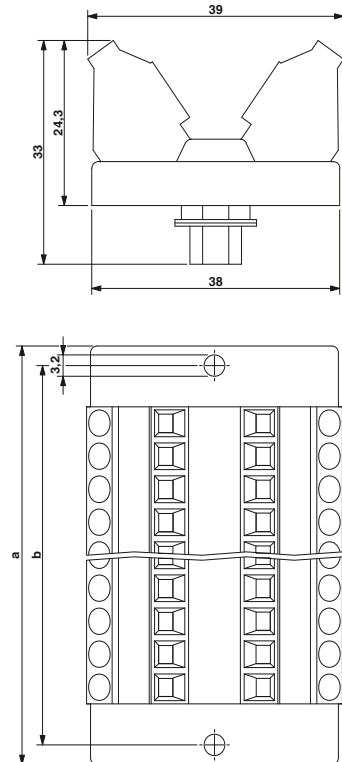

System cabling for controllers

Universal modules

VIP – VARIOFACE Professional Modules for high-density D-SUB connectors

- 1:1 connection
- 15 to 62-pos.
- Screw and Push-in connection
- Metal foot

The D-SUB-4-40 UNC threads are led directly to a connection terminal block.



15 to 62-pos.
with screw connection

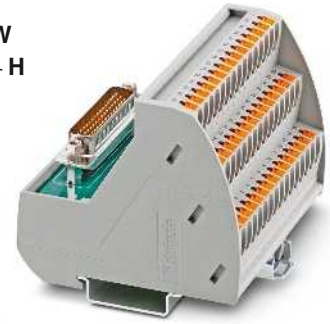

15 to 62-pos.
with Push-in connection

Notes:
For marking systems (e.g., "ZB 22:UNBEDRUCKT"; Order No. 0811862) and mounting material, see Catalog 3.
1) Module with double-level terminal blocks



Maximum permissible operating voltage
Maximum permissible operating voltage UL / CSA

Maximum permissible current (per branch)
Ambient temperature (operation)
Mounting position
Standards/regulations

Connection data solid/stranded/AWG
Dimensions

H / D

25 V AC / 60 V DC
125 V / -
1 A
-20 °C ... 50 °C
any
EN 50178
0.2 - 4 mm² / 0.2 - 2.5 mm² / 24 - 12
69 mm / 62 mm

25 V AC / 60 V DC
125 V / 105 V
1 A
-20 °C ... 50 °C
any
EN 50178
0.14 - 2.5 mm² / 0.14 - 2.5 mm² / 26 - 14
75.8 mm / 63 mm

Technical data

Technical data

Ordering data

Ordering data

Description	No. of pos.	Module width W
VARIOFACE module, with D-Subminiature pin strip		
with screw connection	26	52.30
with screw connection	44	82.90
with screw connection	62	113.50
with Push-in connection	26	52.00
with Push-in connection	44	82.50
with Push-in connection	62	113.00
VARIOFACE module, with D-Subminiature socket strip		
with screw connection 1)	15	44.90
with screw connection	26	52.30
with screw connection	44	82.90
with screw connection	62	113.50
with Push-in connection 1)	15	46.90
with Push-in connection	26	52.00
with Push-in connection	44	82.50
with Push-in connection	62	113.00

Type	Order No.	Pcs./ Pkt.
VIP-3/SC/HD26SUB/M	2322375	1
VIP-3/SC/HD44SUB/M	2322388	1
VIP-3/SC/HD62SUB/M	2322391	1
VIP-2/SC/HD15SUB/F	2322401	1
VIP-3/SC/HD26SUB/F	2322414	1
VIP-3/SC/HD44SUB/F	2322427	1
VIP-3/SC/HD62SUB/F	2322430	1

Type	Order No.	Pcs./ Pkt.
VIP-3/PT/HD26SUB/M	2904269	1
VIP-3/PT/HD44SUB/M	2904270	1
VIP-3/PT/HD62SUB/M	2904271	1
VIP-2/PT/HD15SUB/F	2904272	1
VIP-3/PT/HD26SUB/F	2904273	1
VIP-3/PT/HD44SUB/F	2904274	1
VIP-3/PT/HD62SUB/F	2904275	1

Modules with RJ45 connector

- 1:1 connection
- RJ45 connector, 8-pos.
- Screw or Push-in connection (direct plug-in technology)
- Connector housing led to separate connection terminal blocks

Notes:
For marking systems (e.g., "ZB 22:UNBEDRUCKT"; Order No. 0811862) and mounting material, see Catalog 3.



8-pos.
with screw connection



8-pos.
with Push-in connection

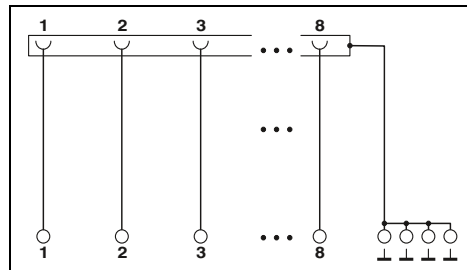

Technical data

Maximum permissible operating voltage	48 V AC/DC
Maximum permissible current (per branch)	1 A
Ambient temperature (operation)	-20 °C ... 50 °C
Mounting position	any
Standards/regulations	DIN EN 50178
Connection data solid/stranded/AWG	0.2 - 4 mm ² / 0.2 - 2.5 mm ² / 24 - 12
Dimensions	69 mm / 62 mm

H / D

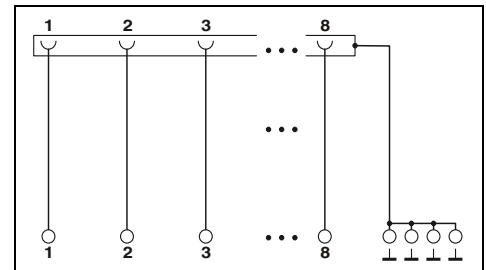

Technical data

Maximum permissible operating voltage	48 V AC/DC
Maximum permissible current (per branch)	1 A
Ambient temperature (operation)	-20 °C ... 50 °C
Mounting position	any
Standards/regulations	EN 50178
Connection data solid/stranded/AWG	0.14 - 2.5 mm ² / 0.14 - 2.5 mm ² / 26 - 14
Dimensions	75.8 mm / 63 mm

Ordering data

Type	Order No.	Pcs./ Pkt.
VIP-3/SC/RJ45	2900701	1

Ordering data

Type	Order No.	Pcs./ Pkt.
VIP-3/PT/RJ45	2904290	1

Description	No. of pos.	Module width W
VARIOFACE module, with RJ45 connector		
with screw connection	8	26.90
with Push-in connection	8	26.60

Modules for ELCO connectors

These modules can be used to connect ELCO connectors of the 8016 series to screw connection terminal blocks.

Thanks to the slanted placement of the ELCO connector, the cables which are fed out of the side of the cable housing are led away without affecting the neighboring modules.

Notes:
Dimensional drawings and pin assignments, see page 600

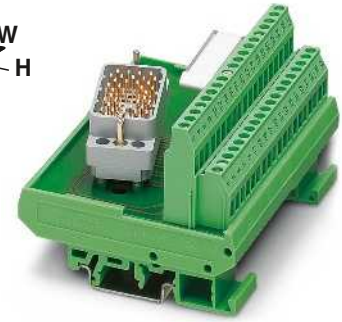

38-pos.

ERC

Technical data

Maximum permissible operating voltage	25 V AC / 60 V DC
Maximum permissible current (per branch)	2 A
Total current	76 A
Ambient temperature (operation)	-20 °C ... 40 °C
Mounting position	any
Standards/regulations	IEC 60664 , DIN EN 50178
Connection data solid/stranded/AWG	0.2 - 4 mm ² / 0.2 - 2.5 mm ² / 24 - 12
Dimensions	H / D 77 mm / 58.5 mm

Ordering data

Description	No. of pos.	Module width W	Type	Order No.	Pcs./ Pkt.
VARIOFACE module, with:					
- Pin strip 8016 right	38	101.50	UMK- EC38/38-XOR	2976297	1
- Pin strip 8016 left	38	101.50	UMK- EC38/38-XOL	2976284	1
VARIOFACE module, with:					
- Pin strip 8016 right	56	157.50			
- Pin strip 8016 left	56	157.50			
VARIOFACE module, with:					
- Pin strip 8016 right	56	77.00			
- Pin strip 8016 left	56	77.00			
VARIOFACE module, with:					
- Pin strip 8016 right above	32	101.30			
- Pin strip 8016 right below	32	101.30			
- Pin strip 8016 left above	32	101.30			
- Pin strip 8016 left below	32	101.30			

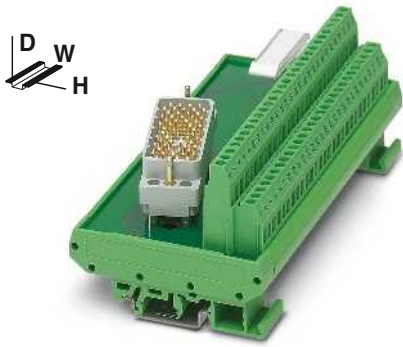

56-pos.

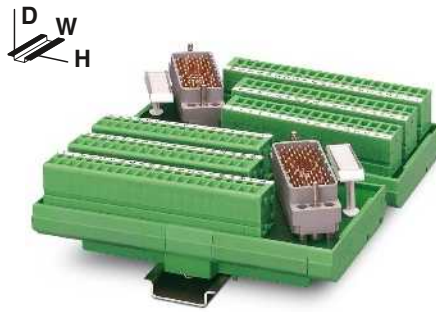

56-pos.,
with front connection terminal blocks

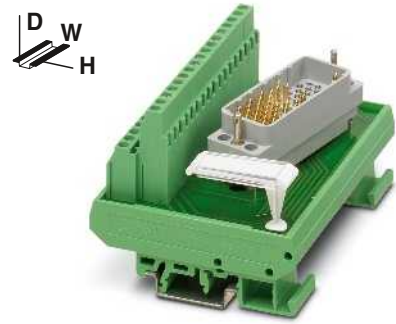

32-pos.

ERC

ERC

ERC

Technical data
125 V AC/DC
1.5 A
28 A (56 branches with 0.5 A each)
-20 °C ... 50 °C
any
IEC 60664 , DIN EN 50178
0.2 - 4 mm ² / 0.2 - 2.5 mm ² / 24 - 12
77 mm / 58.5 mm

Technical data
25 V AC / 60 V DC
1.5 A
28 A (56 branches with 0.5 A each)
-20 °C ... 50 °C
any
IEC 60664 , DIN EN 50178
0.2 - 2.5 mm ² / 0.2 - 1.5 mm ² / 26 - 16
146.3 mm / 47.5 mm

Technical data
25 V AC / 60 V DC
2 A
32 A (32 branches with 1 A each)
-20 °C ... 40 °C
any
IEC 60664 , DIN EN 50178
0.2 - 4 mm ² / 0.2 - 2.5 mm ² / 24 - 12
77 mm / 58.5 mm

Ordering data		
Type	Order No.	Pcs./ Pkt.
UMK- EC56/56-XOR	2975900	1
UMK- EC56/56-XOL	2975890	1

Ordering data		
Type	Order No.	Pcs./ Pkt.
UMK- EC56/FRONT 2,5V/R	2976161	1
UMK- EC56/FRONT 2,5V/L	2976158	1

Ordering data		
Type	Order No.	Pcs./ Pkt.
UMK- EC56/32-XOR	2975858	1
UMK- EC56/32-XUR	2975777	1
UMK- EC56/32-XOL	2975764	1
UMK- EC56/32-XUL	2975780	1

System cabling for controllers

Universal modules

Modules for ELCO connectors for use in Ex i circuits

The VARIOFACE modules connect ELCO connectors from the 8016 series to screw connection terminal blocks. The modules for ELCO connectors are regarded as simple electrical equipment according to EN 60079-14 for use in intrinsically safe circuits. They meet the requirements of intrinsic safety protection according to EN 60079-11 (EN 50020) and are also used for various intrinsically safe circuits, taking the pin assignment into account.

The voltage of an intrinsically safe circuit may not exceed 30 V. The voltage difference between two intrinsically safe circuits can be up to 60 V.

For clear identification of intrinsically safe circuits, the modules are assembled with blue screw connection terminal blocks.

Thanks to the slanted placement of the ELCO connector, the cables which are fed out of the side of the cable housing are led away without affecting the neighboring modules.

For the separation of intrinsically safe and non-intrinsically safe circuits, a distance of at least 50 mm should be maintained between the connection points using partition plates or spaces.

Notes:
Dimensional drawings and pin assignments, see page 601
Facts about explosion protection, see page 108

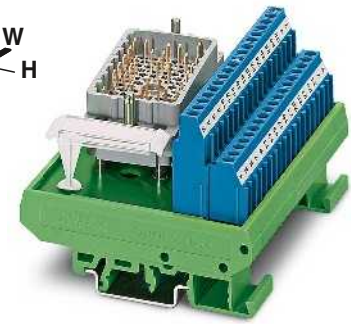

32-pos.

Maximum permissible operating voltage	
Maximum permissible current (per branch)	
Ambient temperature (operation)	
Mounting position	
Standards/regulations	
Connection data solid/stranded/AWG	
Dimensions	H / D

Technical data
max. 30 V DC (Max. voltage between two intrinsically safe circuits: 60 V DC)
500 mA
-20 °C ... 50 °C
any
DIN EN 60079-11
0.2 - 4 mm ² / 0.2 - 2.5 mm ² / 24 - 12
77 mm / 58.5 mm

Description	No. of pos.	Module width W
VARIOFACE module, with:		
- Pin strip 8016 right above	32	101.30
- Pin strip 8016 right below	32	101.30
- Pin strip 8016 left above	32	101.30
- Pin strip 8016 left below	32	101.30
VARIOFACE module, with:		
- Pin strip 8016 right	25	78.80
- Pin strip 8016 left	25	78.80
VARIOFACE module, with:		
- Pin strip 8016 right	25	77.00
- Pin strip 8016 left	25	77.00

Ordering data		
Type	Order No.	Pcs./ Pkt.
UMK- EC90/32/EX-XOR	2900109	1
UMK- EC90/32/EX-XUR	2969068	1
UMK- EC90/32/EX-XOL	2900110	1
UMK- EC90/32/EX-XUL	2969071	1

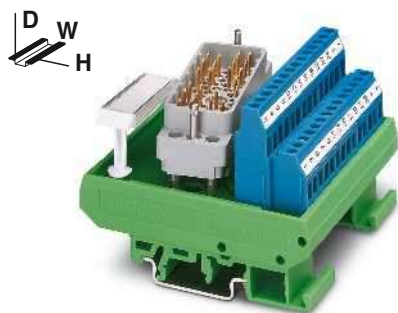

25-pos.

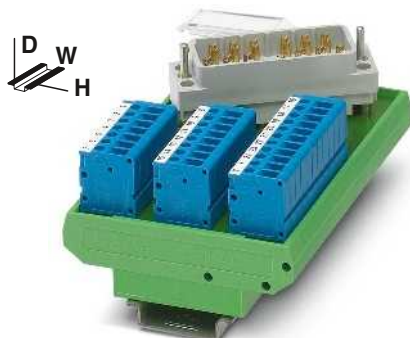

25-pos.,
with front connection terminal blocks

ERC

Technical data

max. 30 V DC
(Max. voltage between two intrinsically safe circuits: 60 V DC)
500 mA
-20 °C ... 50 °C
any
DIN EN 60079-11
0.2 - 4 mm² / 0.2 - 2.5 mm² / 24 - 12
77 mm / 58.5 mm

Technical data

max. 30 V DC
(Max. voltage between two intrinsically safe circuits: 60 V DC)
500 mA
-20 °C ... 50 °C
any
DIN EN 60079-11
0.2 - 2.5 mm² / 0.2 - 2.5 mm² / 24 - 14
112.5 mm / 52.5 mm

Ordering data

Type	Order No.	Pcs./ Pkt.
UMK- EC56/25/EX -R	2900112	1
UMK- EC56/25/EX -L	2900113	1

Ordering data

Type	Order No.	Pcs./ Pkt.
UMK- EC56/25/EX -FRONT 2,5V/R	2900114	1
UMK- EC56/25/EX -FRONT 2,5V/L	2900115	1

System cabling for controllers

Universal cables

VIP – VARIOFACE Professional System cable with IDC/FLK socket strip

- 1:1 connection
- IDC/FLK connector according to IEC 60603-13
- In the desired lengths
- Individual serial number

Note:

Module designs with UM 45 profile and three-level terminal blocks cannot be connected to the VIP-CAB-FLK... system cable due to the larger outer contour of the connectors.

The VIP-CAB-FLK... system cables are not suitable for front adapters.



Unshielded



Technical data

Maximum permissible operating voltage	< 50 V AC / 60 V DC
Maximum permissible operating voltage UL / CSA	125 V / -
Maximum permissible current carrying capacity per path	1 A
Maximum conductor resistance	0.16 Ω/m
Ambient temperature (operation)	-20 °C ... 50 °C
Assembly	Insulation displacement, IEC 60352-4/DIN EN 60352-4
Conductor cross section	AWG 26 / 0.14 mm ²
Outside diameter	10-pos. 6.1 mm 14-pos. 6.4 mm 40-pos. 9.9 mm

Ordering data

Description	No. of pos.	Cable length	Type	Order No.	Pcs./ Pkt.
Round cable, with 2 molded IDC/FLK socket strips					
	10	1 m	VIP-CAB-FLK10/0,14/1,0M	2318318	1
	10	2 m	VIP-CAB-FLK10/0,14/2,0M	2318334	1
	10	3 m	VIP-CAB-FLK10/0,14/3,0M	2318347	1
Round cable, as above, in variable lengths (minimum ordering quantity five pieces)	10		VIP-CAB-FLK10-0,14/...	2318376	1
Round cable, with 2 molded IDC/FLK socket strips					
	14	1 m	VIP-CAB-FLK14/0,14/1,0M	2318392	1
	14	2 m	VIP-CAB-FLK14/0,14/2,0M	2318415	1
	14	3 m	VIP-CAB-FLK14/0,14/3,0M	2318428	1
Round cable, as above, in variable lengths (minimum ordering quantity five pieces)	14		VIP-CAB-FLK14-0,14/...	2318457	1
Round cable, with 2 molded IDC/FLK socket strips					
	40	1 m	VIP-CAB-FLK40/0,14/1,0M	2318790	1
	40	2 m	VIP-CAB-FLK40/0,14/2,0M	2318813	1
	40	3 m	VIP-CAB-FLK40/0,14/3,0M	2318826	1
Round cable, as above, in variable lengths (minimum ordering quantity five pieces)	40		VIP-CAB-FLK40-0,14/...	2318855	1

Ordering example for system cable:

– 10-pos. cable, 7.6 m long

Quantity	Order No.	Length [m]
1	2318376	7.6
		min. 0.5 m
		max. 100.0 m
		Increment 0.1 m

System cabling for controllers

Universal cables

System cable with IDC/FLK socket strip and an open end

- 1:1 connection
- 10, 14, and 16-pos.
- IDC/FLK connector according to IEC 60603-13
- Open end at the other end

The individual wires at the open end are marked (1, 2, 3, 4, ...) and fitted with a ferrule.



Encapsulated connectors, unshielded



Unshielded



Technical data

Maximum permissible operating voltage	< 50 V AC / 60 V DC
Maximum permissible operating voltage UL / CSA	125 V / 125 V
Maximum permissible current carrying capacity per path	1 A
Maximum conductor resistance	0.16 Ω/m
Ambient temperature (operation)	-20 °C ... 50 °C
Assembly	Insulation displacement, IEC 60352-4/DIN EN 60352-4
Conductor cross section	AWG 26 / 0.14 mm ²
Conductor structure: stranded wires / material	7 / Cu tin-plated
Outside diameter	10-pos. 6.1 mm 14-pos. 6.4 mm 16-pos. 6.5 mm



Technical data

Maximum permissible operating voltage	< 50 V AC / 60 V DC
Maximum permissible operating voltage UL / CSA	125 V / 125 V
Maximum permissible current carrying capacity per path	1 A
Maximum conductor resistance	0.16 Ω/m
Ambient temperature (operation)	-20 °C ... 50 °C
Assembly	Insulation displacement, IEC 60352-4/DIN EN 60352-4
Conductor cross section	AWG 26 / 0.14 mm ²
Conductor structure: stranded wires / material	7 / Cu tin-plated
Outside diameter	6.1 mm 6.4 mm 6.5 mm

Ordering data

Description	No. of pos.	Cable length
Round cable with an open end		
	10	0.5 m
	10	1 m
	10	1.5 m
	10	2 m
	10	2.5 m
	10	3 m
	10	4 m
	10	6 m
	10	8 m
	10	10 m
Round cable, as above, but in variable lengths	10	
Round cable with an open end		
	14	0.5 m
	14	1 m
	14	1.5 m
	14	2 m
	14	2.5 m
	14	3 m
	14	4 m
	14	6 m
	14	8 m
	14	10 m
Round cable, as above, but in variable lengths	14	
Round cable with an open end		
	16	0.5 m
	16	1 m
	16	1.5 m
	16	2 m
	16	2.5 m
	16	3 m
	16	4 m
	16	6 m
	16	8 m
	16	10 m
Round cable, as above, but in variable lengths	16	

Type	Order No.	Pcs./ Pkt.
VIP-CAB-FLK14/FR/OE/0,14/0,5M	2900122	1
VIP-CAB-FLK14/FR/OE/0,14/1,0M	2900123	1
VIP-CAB-FLK14/FR/OE/0,14/1,5M	2900125	1
VIP-CAB-FLK14/FR/OE/0,14/2,0M	2900126	1
VIP-CAB-FLK14/FR/OE/0,14/3,0M	2900127	1
VIP-CAB-FLK16/FR/OE/0,14/0,5M	2900130	1
VIP-CAB-FLK16/FR/OE/0,14/1,0M	2900131	1
VIP-CAB-FLK16/FR/OE/0,14/1,5M	2900132	1
VIP-CAB-FLK16/FR/OE/0,14/2,0M	2900133	1
VIP-CAB-FLK16/FR/OE/0,14/3,0M	2900134	1

Ordering data

Type	Order No.	Pcs./ Pkt.
CABLE-FLK10/OE/0,14/ 0,5M	2904073	1
CABLE-FLK10/OE/0,14/ 1,0M	2904074	1
CABLE-FLK10/OE/0,14/ 1,5M	2904075	1
CABLE-FLK10/OE/0,14/ 2,0M	2904076	1
CABLE-FLK10/OE/0,14/ 2,5M	2904077	1
CABLE-FLK10/OE/0,14/ 3,0M	2904078	1
CABLE-FLK10/OE/0,14/ 4,0M	2904079	1
CABLE-FLK10/OE/0,14/ 6,0M	2904080	1
CABLE-FLK10/OE/0,14/ 8,0M	2904081	1
CABLE-FLK10/OE/0,14/10,0M	2904082	1
CABLE-FLK10-OE-0,14/...	2904331	1
CABLE-FLK14/OE/0,14/ 50	2305761	1
CABLE-FLK14/OE/0,14/ 100	2305253	1
CABLE-FLK14/OE/0,14/ 150	2305266	1
CABLE-FLK14/OE/0,14/ 200	2305279	1
CABLE-FLK14/OE/0,14/ 250	2305282	1
CABLE-FLK14/OE/0,14/ 300	2305295	1
CABLE-FLK14/OE/0,14/ 400	2305774	1
CABLE-FLK14/OE/0,14/ 600	2305787	1
CABLE-FLK14/OE/0,14/ 800	2305790	1
CABLE-FLK14/OE/0,14/1000	2305800	1
CABLE-FLK14/OE/0,14/...	2305732	1
CABLE-FLK16/OE/0,14/ 0,5M	2318127	1
CABLE-FLK16/OE/0,14/ 1,0M	2318130	1
CABLE-FLK16/OE/0,14/ 1,5M	2318143	1
CABLE-FLK16/OE/0,14/ 2,0M	2318156	1
CABLE-FLK16/OE/0,14/ 2,5M	2318169	1
CABLE-FLK16/OE/0,14/ 3,0M	2318172	1
CABLE-FLK16/OE/0,14/ 4,0M	2318185	1
CABLE-FLK16/OE/0,14/ 6,0M	2318198	1
CABLE-FLK16/OE/0,14/ 8,0M	2318208	1
CABLE-FLK16/OE/0,14/10,0M	2318211	1
CABLE-FLK16/OE/0,14/...	2318224	1

System cable with IDC/FLK socket strip and an open end

- 1:1 connection
 - 20- and 50-pos.
 - IDC/FLK connector according to IEC 60603-13
 - Open end at the other end
- The individual wires at the open end are marked (1, 2, 3, 4, ...) and fitted with a ferrule.



Encapsulated connectors, unshielded



Unshielded



Technical data

Maximum permissible operating voltage	< 50 V AC / 60 V DC
Maximum permissible operating voltage UL / CSA	125 V / 125 V
Maximum permissible current carrying capacity per path	1 A
Maximum conductor resistance	0.16 Ω/m
Ambient temperature (operation)	-20 °C ... 50 °C
Assembly	Insulation displacement, IEC 60352-4/DIN EN 60352-4
Conductor cross section	AWG 26 / 0.14 mm ²
Conductor structure: stranded wires / material	7 / Cu tin-plated
Outside diameter	20-pos. 7.6 mm 50-pos. 10.3 mm



Technical data

Maximum permissible operating voltage	< 50 V AC / 60 V DC
Maximum permissible operating voltage UL / CSA	125 V / 125 V
Maximum permissible current carrying capacity per path	1 A
Maximum conductor resistance	0.16 Ω/m
Ambient temperature (operation)	-20 °C ... 50 °C
Assembly	Insulation displacement, IEC 60352-4/DIN EN 60352-4
Conductor cross section	AWG 26 / 0.14 mm ²
Conductor structure: stranded wires / material	7 / Cu tin-plated
Outside diameter	7.6 mm 10.3 mm

Ordering data

Description	No. of pos.	Cable length	Type	Order No.	Pcs./ Pkt.
Round cable with an open end	20	0.5 m	VIP-CAB-FLK20/FR/OE/0,14/1,0M	2900139	1
	20	1 m			
	20	1.5 m			
	20	2 m	VIP-CAB-FLK20/FR/OE/0,14/2,0M	2900142	1
	20	2.5 m	VIP-CAB-FLK20/FR/OE/0,14/3,0M	2900143	1
	20	3 m			
	20	4 m			
	20	6 m			
	20	8 m			
	20	10 m			
Round cable, as above, but in variable lengths	20				
Round cable with an open end	50	0.5 m			
	50	1 m			
	50	1.5 m			
	50	2 m			
	50	2.5 m			
	50	3 m			
	50	4 m			
	50	6 m			
	50	8 m			
	50	10 m			
Round cable, as above, but in variable lengths	50				

Ordering data

Type	Order No.	Pcs./ Pkt.
CABLE-FLK20/OE/0,14/ 50	2305826	1
CABLE-FLK20/OE/0,14/ 100	2305305	1
CABLE-FLK20/OE/0,14/ 150	2305318	1
CABLE-FLK20/OE/0,14/ 200	2305321	1
CABLE-FLK20/OE/0,14/ 250	2305334	1
CABLE-FLK20/OE/0,14/ 300	2305347	1
CABLE-FLK20/OE/0,14/ 400	2305839	1
CABLE-FLK20/OE/0,14/ 600	2305842	1
CABLE-FLK20/OE/0,14/ 800	2305855	1
CABLE-FLK20/OE/0,14/1000	2305868	1
CABLE-FLK20/OE/0,14/...	2305745	1
CABLE-FLK50/OE/0,14/ 50	2305871	1
CABLE-FLK50/OE/0,14/ 100	2305350	1
CABLE-FLK50/OE/0,14/ 150	2305363	1
CABLE-FLK50/OE/0,14/ 200	2305376	1
CABLE-FLK50/OE/0,14/ 250	2305389	1
CABLE-FLK50/OE/0,14/ 300	2305392	1
CABLE-FLK50/OE/0,14/ 400	2305884	1
CABLE-FLK50/OE/0,14/ 600	2305897	1
CABLE-FLK50/OE/0,14/ 800	2305907	1
CABLE-FLK50/OE/0,14/1000	2305910	1
CABLE-FLK50/OE/0,14/...	2305758	1

System cabling for controllers

Universal cables

System cable with IDC/FLK socket strips

Standard lengths

Round cable sets are used to connect the PLC front adapters to the corresponding VARIOFACE termination boards.

The following versions are available with 14 and 50 positions:

- Unshielded
- Shielded
- Halogen-free

The cables are assembled at both ends with IDC/FLK socket strips according to IEC 60603-13/DIN 41651 (1:1 connection).

In the case of shielded cables, a cable end with a ferrule is additionally provided as a shield connection (length: approx. 0.5 m; cable H05V-K 1 mm², black).

Special lengths are defined using an order key, refer to page 590.



Unshielded



Technical data

Maximum permissible operating voltage	< 50 V AC / 60 V DC
Maximum permissible operating voltage UL / CSA	125 V / 125 V
Maximum permissible current carrying capacity per path	1 A
Maximum conductor resistance	0.16 Ω/m
Ambient temperature (operation)	-20 °C ... 50 °C
Shield	-
Assembly	Insulation displacement, IEC 60352-4/DIN EN 60352-4
Conductor cross section	AWG 26 / 0.14 mm ²
Conductor structure: stranded wires / material	7 / Cu tin-plated
Outside diameter	14-pos. 6.4 mm 50-pos. 10.3 mm

Ordering data

Description	No. of pos.	Cable length	Type	Order No.	Pcs./ Pkt.
Assembled round cable¹⁾ , with two 14-pos. IDC/FLK socket strips in fixed lengths, for transfer of 8 channels, for example					
	14	0.3 m	FLK 14/EZ-DR/ 30/KONFEK	2295729	5
	14	0.5 m	FLK 14/EZ-DR/ 50/KONFEK	2288901	5
	14	1 m	FLK 14/EZ-DR/ 100/KONFEK	2288914	1
	14	1.5 m	FLK 14/EZ-DR/ 150/KONFEK	2288927	1
	14	2 m	FLK 14/EZ-DR/ 200/KONFEK	2288930	1
	14	2.5 m	FLK 14/EZ-DR/ 250/KONFEK	2288943	1
	14	3 m	FLK 14/EZ-DR/ 300/KONFEK	2288956	1
	14	3.5 m	FLK 14/EZ-DR/ 350/KONFEK	2288969	1
	14	4 m	FLK 14/EZ-DR/ 400/KONFEK	2288972	1
	14	4.5 m	FLK 14/EZ-DR/ 450/KONFEK	2290847	1
	14	5 m	FLK 14/EZ-DR/ 500/KONFEK	2290834	1
	14	5.5 m	FLK 14/EZ-DR/ 550/KONFEK	2290850	1
	14	6 m	FLK 14/EZ-DR/ 600/KONFEK	2290863	1
	14	7 m			
	14	8 m	FLK 14/EZ-DR/ 800/KONFEK	2299563	1
	14	10 m	FLK 14/EZ-DR/1000/KONFEK	2299576	1
Assembled round cable²⁾ , with two 50-pos. IDC/FLK socket strips in fixed lengths, for transfer of 32 channels, for example					
	50	0.5 m	FLK 50/EZ-DR/ 50/KONFEK	2289065	5
	50	1 m	FLK 50/EZ-DR/ 100/KONFEK	2289078	1
	50	1.5 m	FLK 50/EZ-DR/ 150/KONFEK	2289081	1
	50	2 m	FLK 50/EZ-DR/ 200/KONFEK	2289094	1
	50	2.5 m	FLK 50/EZ-DR/ 250/KONFEK	2289104	1
	50	3 m	FLK 50/EZ-DR/ 300/KONFEK	2289117	1
	50	3.5 m	FLK 50/EZ-DR/ 350/KONFEK	2289120	1
	50	4 m	FLK 50/EZ-DR/ 400/KONFEK	2289133	1
	50	4.5 m	FLK 50/EZ-DR/ 450/KONFEK	2289573	1
	50	5 m	FLK 50/EZ-DR/ 500/KONFEK	2289586	1
	50	5.5 m	FLK 50/EZ-DR/ 550/KONFEK	2289599	1
	50	6 m	FLK 50/EZ-DR/ 600/KONFEK	2289609	1
	50	6.5 m	FLK 50/EZ-DR/ 650/KONFEK	2289612	1
	50	7 m	FLK 50/EZ-DR/ 700/KONFEK	2289625	1
	50	7.5 m	FLK 50/EZ-DR/ 750/KONFEK	2289638	1
	50	8 m	FLK 50/EZ-DR/ 800/KONFEK	2289641	1
	50	8.5 m	FLK 50/EZ-DR/ 850/KONFEK	2289654	1
	50	9 m	FLK 50/EZ-DR/ 900/KONFEK	2289667	1
	50	9.5 m	FLK 50/EZ-DR/ 950/KONFEK	2289670	1
	50	10 m	FLK 50/EZ-DR/1000/KONFEK	2289683	1



Shield connection at one end



Halogen-free (only the cable)

ERC
Applied for: cUL / UL

ERC

Technical data	
< 50 V AC / 60 V DC 125 V / -	
1 A	
0.16 Ω/m -20 °C ... 50 °C Tinned copper-braided shield, approx. 85% covering	
Insulation displacement, IEC 60352-4/DIN EN 60352-4	
AWG 26 / 0.14 mm ² 7 / Cu tin-plated	
6.7 mm 11 mm	

Technical data	
< 50 V AC / 60 V DC 125 V / 125 V	
1 A	
0.16 Ω/m -20 °C ... 50 °C -	
Insulation displacement, IEC 60352-4/DIN EN 60352-4	
AWG 26 / 0.14 mm ² 7 / Cu tin-plated	
6.4 mm 10.3 mm	

Ordering data		
Type	Order No.	Pcs./ Pkt.
FLK 14/EZ-DR/ 50/KONFEK/S	2296977	1
FLK 14/EZ-DR/ 100/KONFEK/S	2296980	1
FLK 14/EZ-DR/ 150/KONFEK/S	2296993	1
FLK 14/EZ-DR/ 200/KONFEK/S	2297002	1
FLK 14/EZ-DR/ 300/KONFEK/S	2299013	1
FLK 14/EZ-DR/ 400/KONFEK/S	2299026	1
FLK 14/EZ-DR/ 600/KONFEK/S	2299039	1
FLK 14/EZ-DR/ 800/KONFEK/S	2299042	1
FLK 14/EZ-DR/1000/KONFEK/S	2299055	1
FLK 50/EZ-DR/ 50/KONFEK/S	2299097	1
FLK 50/EZ-DR/ 100/KONFEK/S	2299107	1
FLK 50/EZ-DR/ 150/KONFEK/S	2299110	1
FLK 50/EZ-DR/ 200/KONFEK/S	2299123	1
FLK 50/EZ-DR/ 300/KONFEK/S	2299136	1
FLK 50/EZ-DR/ 400/KONFEK/S	2299149	1
FLK 50/EZ-DR/ 600/KONFEK/S	2299152	1
FLK 50/EZ-DR/ 800/KONFEK/S	2299165	1
FLK 50/EZ-DR/1000/KONFEK/S	2299178	1

Ordering data		
Type	Order No.	Pcs./ Pkt.
FLK 14/EZ-DR/HF/ 50/KONFEK	2305952	1
FLK 14/EZ-DR/HF/ 100/KONFEK	2305965	1
FLK 14/EZ-DR/HF/ 150/KONFEK	2305978	1
FLK 14/EZ-DR/HF/ 200/KONFEK	2305981	1
FLK 14/EZ-DR/HF/ 250/KONFEK	2305994	1
FLK 14/EZ-DR/HF/ 300/KONFEK	2304759	1
FLK 14/EZ-DR/HF/ 400/KONFEK	2304762	1
FLK 14/EZ-DR/HF/ 500/KONFEK	2304717	1
FLK 14/EZ-DR/HF/ 600/KONFEK	2306003	1
FLK 14/EZ-DR/HF/ 700/KONFEK	2314011	1
FLK 14/EZ-DR/HF/ 800/KONFEK	2314024	1
FLK 14/EZ-DR/HF/1000/KONFEK	2314037	1
CABLE-FLK50/0,14/HF/ 0,5M	2314134	1
CABLE-FLK50/0,14/HF/ 1,0M	2314147	1
CABLE-FLK50/0,14/HF/ 1,5M	2314150	1
CABLE-FLK50/0,14/HF/ 2,0M	2314163	1
CABLE-FLK50/0,14/HF/ 2,5M	2314176	1
CABLE-FLK50/0,14/HF/ 3,0M	2314189	1
CABLE-FLK50/0,14/HF/ 4,0M	2314192	1
CABLE-FLK50/0,14/HF/ 5,0M	2314202	1
CABLE-FLK50/0,14/HF/ 6,0M	2314215	1
CABLE-FLK50/0,14/HF/ 7,0M	2314228	1
CABLE-FLK50/0,14/HF/ 8,0M	2314231	1
CABLE-FLK50/0,14/HF/10,0M	2314244	1

Color code of system cables

Wire No.	Pin	Wire color
	1	Black
	2	Brown
	3	Red
	4	Orange
	5	Yellow
	6	Green
	7	Blue
	8	Violet
	9	Gray
10-pos.	10	White
	11	White-black
	12	White-brown
14-pos.	13	White-red
	14	White-orange
	15	White-yellow
16-pos.	16	White-green
	17	White-blue
	18	White-violet
20-pos.	19	White-gray
	20	Brown-black
	21	Brown-red
	22	Brown-orange
	23	Brown-yellow
	24	Brown-green
26-pos.	25	Brown-blue
	26	Brown-violet
	27	Brown-gray
	28	Brown-white
	29	Green-black
	30	Green-brown
	31	Green-red
	32	Green-orange
	33	Green-blue
34-pos.	34	Green-violet
	35	Green-gray
	36	Green-white
	37	Yellow-black
	38	Yellow-brown
	39	Yellow-red
40-pos.	40	Yellow-orange
	41	Yellow-blue
	42	Yellow-violet
	43	Yellow-gray
	44	Yellow-white
	45	Gray-black
	46	Gray-brown
	47	Gray-red
	48	Gray-orange
	49	Gray-yellow
50-pos.	50	Gray-green

1) IDC/FLK socket strip assembled straight at both ends.

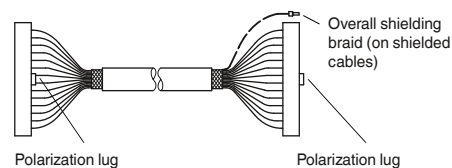

2) IDC/FLK socket strip assembled straight at one end and angled at the other.

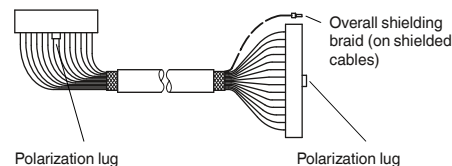

System cabling for controllers

Universal cables

System cable with IDC/FLK socket strips

Standard lengths

Pre-assembled round cables to couple the VARIOFACE termination boards.

The cables are assembled at both ends with IDC/FLK socket strips according to IEC 60603-13/DIN 41651 (1:1 connection).

Special lengths are defined using an order key, refer to page 590.



Unshielded



Applied for: cUL / UL

Technical data

Maximum permissible operating voltage	< 50 V AC / 60 V DC
Maximum permissible operating voltage UL / CSA	125 V / 125 V
Maximum permissible current carrying capacity per path	1 A
Maximum conductor resistance	0.16 Ω/m
Ambient temperature (operation)	-20 °C ... 50 °C
Assembly	Insulation displacement, IEC 60352-4/DIN EN 60352-4
Conductor cross section	AWG 26 / 0.14 mm ²
Conductor structure: stranded wires / material	7 / Cu tin-plated
Outside diameter	10-pos. 6 mm 16-pos. 6.5 mm 20-pos. 7.6 mm

Ordering data

Description	No. of pos.	Cable length	Type	Order No.	Pcs./ Pkt.
Round cable¹⁾, with two IDC/FLK socket strips					
	10	0.5 m	FLK 10/EZ-DR/ 50/KONFEK	2299204	1
	10	1 m	FLK 10/EZ-DR/ 100/KONFEK	2299217	1
	10	1.5 m	FLK 10/EZ-DR/ 150/KONFEK	2299220	1
	10	2 m	FLK 10/EZ-DR/ 200/KONFEK	2299233	1
	10	3 m	FLK 10/EZ-DR/ 300/KONFEK	2299246	1
	10	4 m	FLK 10/EZ-DR/ 400/KONFEK	2299259	1
	10	6 m	FLK 10/EZ-DR/ 600/KONFEK	2299262	1
	10	8 m	FLK 10/EZ-DR/ 800/KONFEK	2299275	1
	10	10 m	FLK 10/EZ-DR/1000/KONFEK	2299288	1
Round cable¹⁾, with two IDC/FLK socket strips					
	16	0.5 m	FLK 16/EZ-DR/ 50/KONFEK	2299291	1
	16	1 m	FLK 16/EZ-DR/ 100/KONFEK	2299301	1
	16	1.5 m	FLK 16/EZ-DR/ 150/KONFEK	2299314	1
	16	2 m	FLK 16/EZ-DR/ 200/KONFEK	2299327	1
	16	3 m	FLK 16/EZ-DR/ 300/KONFEK	2299330	1
	16	4 m	FLK 16/EZ-DR/ 400/KONFEK	2299343	1
	16	6 m	FLK 16/EZ-DR/ 600/KONFEK	2299356	1
	16	8 m	FLK 16/EZ-DR/ 800/KONFEK	2299369	1
	16	10 m	FLK 16/EZ-DR/1000/KONFEK	2299372	1
Round cable¹⁾, with two IDC/FLK socket strips					
	20	0.5 m	FLK 20/EZ-DR/ 50KONFEK	2296391	1
	20	1 m	FLK 20/EZ-DR/ 100KONFEK	2296401	1
	20	1.5 m	FLK 20/EZ-DR/ 150KONFEK	2296472	1
	20	2 m	FLK 20/EZ-DR/ 200KONFEK	2296485	1
	20	3 m	FLK 20/EZ-DR/ 300KONFEK	2296498	1
	20	4 m	FLK 20/EZ-DR/ 400KONFEK	2296508	1
	20	6 m	FLK 20/EZ-DR/ 600KONFEK	2296511	1
	20	8 m	FLK 20/EZ-DR/ 800KONFEK	2296524	1
	20	10 m	FLK 20/EZ-DR/1000KONFEK	2296537	1

¹⁾ IDC/FLK socket strip assembled straight at both ends.

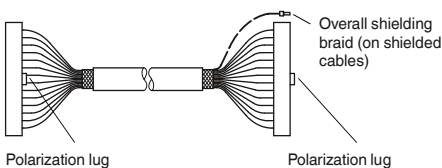

System cable with IDC/FLK socket strips

Standard lengths

Pre-assembled round cables to couple the VARIOFACE termination boards.

The cables are assembled at both ends with IDC/FLK socket strips according to IEC 60603-13/DIN 41651 (1:1 connection).

Special lengths are defined using an order key, refer to page 590.



Unshielded



Technical data

Maximum permissible operating voltage	< 50 V AC / 60 V DC
Maximum permissible operating voltage UL / CSA	125 V / 125 V
Maximum permissible current carrying capacity per path	1 A
Maximum conductor resistance	0.16 Ω/m
Ambient temperature (operation)	-20 °C ... 50 °C
Assembly	Insulation displacement, IEC 60352-4/DIN EN 60352-4
Conductor cross section	AWG 26 / 0.14 mm ²
Conductor structure: stranded wires / material	7 / Cu tin-plated
Outside diameter	
	26-pos. 7.8 mm
	34-pos. 8.7 mm
	40-pos. 9.9 mm

Ordering data

Description	No. of pos.	Cable length	Type	Order No.	Pcs./ Pkt.
Round cable¹⁾, with two IDC/FLK socket strips					
	26	0.5 m	FLK 26/EZ-DR/ 50/KONFEK	2299385	1
	26	1 m	FLK 26/EZ-DR/ 100/KONFEK	2299398	1
	26	1.5 m	FLK 26/EZ-DR/ 150/KONFEK	2299408	1
	26	2 m	FLK 26/EZ-DR/ 200/KONFEK	2299411	1
	26	3 m	FLK 26/EZ-DR/ 300/KONFEK	2299424	1
	26	4 m	FLK 26/EZ-DR/ 400/KONFEK	2299437	1
	26	6 m	FLK 26/EZ-DR/ 600/KONFEK	2299440	1
	26	8 m	FLK 26/EZ-DR/ 800/KONFEK	2299453	1
	26	10 m	FLK 26/EZ-DR/1000/KONFEK	2299466	1
Round cable¹⁾, with two IDC/FLK socket strips					
	34	0.5 m	FLK 34/EZ-DR/ 50/KONFEK	2299479	1
	34	1 m	FLK 34/EZ-DR/ 100/KONFEK	2299482	1
	34	1.5 m	FLK 34/EZ-DR/ 150/KONFEK	2299495	1
	34	2 m	FLK 34/EZ-DR/ 200/KONFEK	2299505	1
	34	3 m	FLK 34/EZ-DR/ 300/KONFEK	2299518	1
	34	4 m	FLK 34/EZ-DR/ 400/KONFEK	2299521	1
	34	6 m	FLK 34/EZ-DR/ 600/KONFEK	2299534	1
	34	8 m	FLK 34/EZ-DR/ 800/KONFEK	2299547	1
	34	10 m	FLK 34/EZ-DR/1000/KONFEK	2299550	1
Round cable²⁾, with two IDC/FLK socket strips					
	40	0.5 m	FLK 40/EZ-DR/ 50/KONFEK	2288985	5
	40	1 m	FLK 40/EZ-DR/ 100/KONFEK	2288998	1
	40	1.5 m	FLK 40/EZ-DR/ 150/KONFEK	2289007	1
	40	2 m	FLK 40/EZ-DR/ 200/KONFEK	2289010	1
	40	2.5 m	FLK 40/EZ-DR/ 250/KONFEK	2289023	1
	40	3 m	FLK 40/EZ-DR/ 300/KONFEK	2289036	1
	40	3.5 m	FLK 40/EZ-DR/ 350/KONFEK	2289049	1
	40	4 m	FLK 40/EZ-DR/ 400/KONFEK	2289052	1
	40	6 m	FLK 40/EZ-DR/ 600/KONFEK	2299589	1
	40	8 m	FLK 40/EZ-DR/ 800/KONFEK	2299592	1
	40	10 m	FLK 40/EZ-DR/1000/KONFEK	2299602	1

²⁾ IDC/FLK socket strip assembled straight at one end and angled at the other.

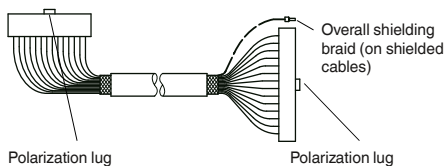

System cabling for controllers

Universal cables

System cables with IDC/FLK socket strip

Special lengths

Pre-assembled round cables for connecting, e.g., PLC front adapters to the corresponding VARIOFACE termination boards. The cables are assembled with IDC/FLK socket strips on both ends according to IEC 60603-13/DIN 41651. For shielded cables, a cable end with ferrule is also available as an overall shielding braid (length: approx. 0.5 m; cable: H05V-K 1 mm², black).

The order key for special lengths is described using three features.

The order of the features is as follows:

- Cable type
- Assembly
- Length in meters

There are two order keys, one for unshielded round cables, FLK EZ-DR/.../.../..., and one for shielded round cables, FLK EZ-DR-S/.../.../... To ensure clear specification when ordering, the features are described in detail below:

Cable type

- This specifies the number of individual cables of the specific cable.

Assembly

- None, the cable is not assembled at either end,
- 10-pos. IDC/FLK socket strip at both ends, the cable is assembled at both ends with 10-pos. IDC/FLK socket strips (1:1 connection),
- 14-pos. IDC/FLK socket strip at both ends, the cable is assembled at both ends with 14-pos. IDC/FLK socket strips

(1:1 connection), etc. to

- 50-pos. IDC/FLK socket strip at both ends, the cable is assembled at both ends with 50-pos. IDC/FLK socket strips (1:1 connection),
- 14-pos. IDC/FLK socket strip at one end, 16-pos. IDC/FLK socket strip at the other end, the cable is assembled with a 14-pos. IDC/FLK socket strip at one end and a 16-pos. IDC/FLK socket strip at the other end (for SIMATIC® S7, no 1:1 connection).

Features of permissible configurations:

Cable type	Unshielded round cables FLK EZ-DR/.../.../...							Shielded round cables FLK EZ-DR-S/.../.../...				
	10-pos.	14-pos.	16-pos.	20-pos.	26-pos.	34-pos.	40-pos.	50-pos.	14-pos.	16-pos.	40-pos.	50-pos.
No assembly	10U/C00/...	14U/C00/...	16U/C00/...	20U/C00/...	26U/C00/...	34U/C00/...	40U/C00/...	50U/C00/...	14S/C00/...	16S/C00/...	40S/C00/...	50S/C00/...
10-pos. IDC/FLK at both ends	10U/C55/... ¹⁾											
14-pos. IDC/FLK at both ends		14U/C23/... ¹⁾										
16-pos. IDC/FLK at both ends			16U/C58/... ¹⁾									
20-pos. IDC/FLK at both ends				20U/C61/... ¹⁾								
26-pos. IDC/FLK at both ends					26U/C63/... ¹⁾							
34-pos. IDC/FLK at both ends						34U/C65/... ¹⁾						
40-pos. IDC/FLK at both ends							40U/C30/... ³⁾				40S/C30/... ³⁾	
50-pos. IDC/FLK at both ends								50U/C38/... ²⁾				50S/C38/... ²⁾
14-pos. IDC/FLK at one end, 16-pos. IDC/FLK at the other end		14U/C52/... ¹⁾								14S/C52/... ¹⁾		

1) IDC/FLK socket strip assembled straight at both ends.

2) IDC/FLK socket strip assembled straight at one end and angled at the other.

3) IDC/FLK socket strip assembled straight at one end and angled at the other.

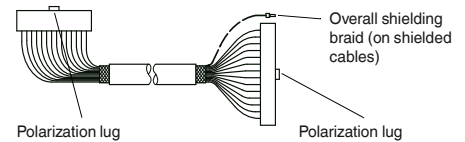
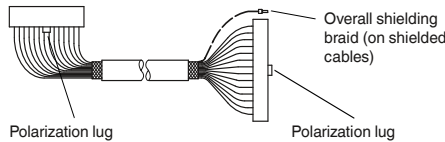
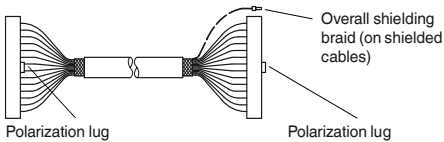

Ordering example for unshielded round cable:

- unshielded 50-pos. round cable, assembled with two 50-pos. IDC/FLK socket strips, 11.5 m long

Quantity	Order No.	Cable type	Assembly	Length [m] ⁴⁾
1	2295059	50U 10U ≙ 10-pos. unshielded 14U ≙ 14-pos. unshielded 16U ≙ 16-pos. unshielded 20U ≙ 20-pos. unshielded 26U ≙ 26-pos. unshielded 34U ≙ 34-pos. unshielded 40U ≙ 40-pos. unshielded 50U ≙ 50-pos. unshielded	C38 C00 ≙ No assembly C55 ≙ 10-pos. IDC/FLK socket strip at both ends C23 ≙ 14-pos. IDC/FLK socket strip at both ends C52 ≙ 14-pos. IDC/FLK socket strip at one end, 16-pos. IDC/FLK socket strip at the other end (for S7) C58 ≙ 16-pos. IDC/FLK socket strip at both ends C61 ≙ 20-pos. IDC/FLK socket strip at both ends C63 ≙ 26-pos. IDC/FLK socket strip at both ends C65 ≙ 34-pos. IDC/FLK socket strip at both ends C30 ≙ 40-pos. IDC/FLK socket strip at both ends C38 ≙ 50-pos. IDC/FLK socket strip at both ends	11.50 ⁴⁾ min. 0.20 m

Ordering example for shielded round cable:

- shielded 14-pos. round cable, assembled with two 14-pos. IDC/FLK socket strips, 12.75 m long

Quantity	Order No.	Cable type	Assembly	Length [m] ⁴⁾
1	2295046	14S 14S ≙ 14-pos. shielded 16S ≙ 16-pos. shielded 40S ≙ 40-pos. shielded 50S ≙ 50-pos. shielded	C23 C00 ≙ No assembly C23 ≙ 14-pos. IDC/FLK socket strip at both ends C52 ≙ 14-pos. IDC/FLK socket strip at one end, 16-pos. IDC/FLK socket strip at the other end (for S7) C58 ≙ 16-pos. IDC/FLK socket strip at both ends C30 ≙ 40-pos. IDC/FLK socket strip at both ends C38 ≙ 50-pos. IDC/FLK socket strip at both ends	12.75 ⁴⁾ min. 0.20 m



Unshielded



Shielded



Technical data	
Maximum permissible operating voltage	< 50 V AC / 60 V DC
Maximum permissible operating voltage UL / CSA	125 V / 125 V
Maximum permissible current carrying capacity per path	1 A
Maximum conductor resistance	0.16 Ω/m
Ambient temperature (operation)	-20 °C ... 50 °C
Shield	-
Conductor cross section	AWG 26 / 0.14 mm ²
Conductor structure: stranded wires / material	7 / Cu tin-plated

Ordering data		
Type	Order No.	Pcs./ Pkt.
FLK EZ-DR.../.../...	2295059	1



Technical data	
Maximum permissible operating voltage	< 50 V AC / 60 V DC
Maximum permissible operating voltage UL / CSA	125 V / 125 V
Maximum permissible current carrying capacity per path	1 A
Maximum conductor resistance	0.16 Ω/m
Ambient temperature (operation)	-20 °C ... 50 °C
Shield	Tinned copper-braided shield, approx. 85% covering
Conductor cross section	AWG 26 / 0.14 mm ²
Conductor structure: stranded wires / material	7 / Cu tin-plated

Ordering data		
Type	Order No.	Pcs./ Pkt.
FLK EZ-DR-S.../.../...	2295046	1

Description	No. of pos.	Cable length
Unshielded round cable, as above, but in variable lengths of type "FLK EZ-DR/14U/C52/..."	10	

System cabling for controllers

Universal cables

System cable with D-SUB socket and pin strips

Standard lengths

Shielded round cable sets to connect the control level with the corresponding VARIOFACE termination boards.

Assembly with D-SUB strips as per IEC 60807-2/DIN 41652, (1:1 connection).

- D-SUB socket strip at one end and D-SUB pin strip at the other
- D-SUB socket strips at both ends
- DSUB pin strips at both ends
- Cable exit: straight
- Screw connection: 2 UNC 4-40 screws

Special lengths and assembly versions are defined using an order key, refer to page 594.



Socket strip at one end and pin strip at the other



Technical data

Maximum permissible operating voltage	25 V AC / 60 V DC
Maximum permissible operating voltage UL / CSA	125 V / 125 V
Maximum permissible current carrying capacity per path	2 A
Maximum conductor resistance	0.09 Ω/m
Ambient temperature (operation)	-20 °C ... 50 °C
Shield	Tinned copper-braided shield, approx. 85% covering
Insertion/withdrawal cycles	> 200
Conductor cross section	AWG 24 / 0.25 mm ²
Outside diameter	
	9-pos. 7.5 mm
	15-pos. 9 mm
	25-pos. 10.5 mm
	37-pos. 12.5 mm
	50-pos. 13.5 mm

Ordering data

Description	No. of pos.	Cable length	Type	Order No.	Pcs./ Pkt.
Shielded round cable , assembled with two D-SUB strips, various numbers of positions and lengths					
	9	0.5 m	CABLE-D 9SUB/B/S/ 50/KONFEK/S	2299987	1
	9	1 m	CABLE-D 9SUB/B/S/100/KONFEK/S	2299990	1
	9	1.5 m	CABLE-D 9SUB/B/S/150/KONFEK/S	2300009	1
	9	2 m	CABLE-D 9SUB/B/S/200/KONFEK/S	2302010	1
	9	3 m	CABLE-D 9SUB/B/S/300/KONFEK/S	2302023	1
	9	4 m	CABLE-D 9SUB/B/S/400/KONFEK/S	2302036	1
	9	6 m	CABLE-D 9SUB/B/S/600/KONFEK/S	2302049	1
	15	0.5 m	CABLE-D15SUB/B/S/ 50/KONFEK/S	2302052	1
	15	1 m	CABLE-D15SUB/B/S/100/KONFEK/S	2302065	1
	15	1.5 m	CABLE-D15SUB/B/S/150/KONFEK/S	2302078	1
	15	2 m	CABLE-D15SUB/B/S/200/KONFEK/S	2302081	1
	15	3 m	CABLE-D15SUB/B/S/300/KONFEK/S	2302094	1
	15	4 m	CABLE-D15SUB/B/S/400/KONFEK/S	2302104	1
	15	6 m	CABLE-D15SUB/B/S/600/KONFEK/S	2302117	1
	25	0.5 m	CABLE-D25SUB/B/S/ 50/KONFEK/S	2302120	1
	25	1 m	CABLE-D25SUB/B/S/100/KONFEK/S	2302133	1
	25	1.5 m	CABLE-D25SUB/B/S/150/KONFEK/S	2302146	1
	25	2 m	CABLE-D25SUB/B/S/200/KONFEK/S	2302159	1
	25	3 m	CABLE-D25SUB/B/S/300/KONFEK/S	2302162	1
	25	4 m	CABLE-D25SUB/B/S/400/KONFEK/S	2302175	1
	25	6 m	CABLE-D25SUB/B/S/600/KONFEK/S	2302188	1
	37	0.5 m	CABLE-D37SUB/B/S/ 50/KONFEK/S	2302191	1
	37	1 m	CABLE-D37SUB/B/S/100/KONFEK/S	2302201	1
	37	2 m	CABLE-D37SUB/B/S/200/KONFEK/S	2302227	1
	37	3 m	CABLE-D37SUB/B/S/300/KONFEK/S	2302230	1
	37	4 m	CABLE-D37SUB/B/S/400/KONFEK/S	2302243	1
	37	6 m	CABLE-D37SUB/B/S/600/KONFEK/S	2302256	1
	37	8 m			
	37	10 m			
	37	15 m			
	37	20 m			
	50	0.5 m	CABLE-D50SUB/B/S/ 50/KONFEK/S	2302269	1
	50	1 m	CABLE-D50SUB/B/S/100/KONFEK/S	2302272	1
	50	1.5 m	CABLE-D50SUB/B/S/150/KONFEK/S	2302285	1
	50	2 m	CABLE-D50SUB/B/S/200/KONFEK/S	2302298	1
	50	3 m	CABLE-D50SUB/B/S/300/KONFEK/S	2302308	1
	50	4 m	CABLE-D50SUB/B/S/400/KONFEK/S	2302311	1
	50	6 m	CABLE-D50SUB/B/S/600/KONFEK/S	2302324	1



Socket strip at both ends



Pin strip at both ends



Socket strip at both ends
Halogen-free



Technical data
25 V AC / 60 V DC 125 V / 125 V 2 A 0.09 Ω/m -20 °C ... 50 °C Tinned copper-braided shield, approx. 85% covering
> 200 AWG 24 / 0.25 mm ²
7.5 mm 9 mm 10.5 mm 12 mm 13.5 mm

Technical data
25 V AC / 60 V DC 125 V / 125 V 2 A 0.09 Ω/m -20 °C ... 50 °C Tinned copper-braided shield, approx. 85% covering
> 200 AWG 24 / 0.25 mm ²
7.5 mm 9 mm 10.5 mm 12 mm 13.5 mm

Technical data
25 V AC / 60 V DC - / - 2 A (50 °C) , 1 A (70 °C) 0.09 Ω/m -20 °C ... 70 °C Tinned copper braided shield
- AWG 24 / 0.25 mm ²
- - - 12.5 mm -

Ordering data		
Type	Order No.	Pcs./ Pkt.
CABLE-D 9SUB/B/B/100/KONFEK/S	2305415	1
CABLE-D 9SUB/B/B/200/KONFEK/S	2305428	1
CABLE-D 9SUB/B/B/300/KONFEK/S	2305431	1
CABLE-D15SUB/B/B/100/KONFEK/S	2305444	1
CABLE-D15SUB/B/B/200/KONFEK/S	2305457	1
CABLE-D15SUB/B/B/300/KONFEK/S	2305460	1
CABLE-D25SUB/B/B/100/KONFEK/S	2305473	1
CABLE-D25SUB/B/B/200/KONFEK/S	2305486	1
CABLE-D25SUB/B/B/300/KONFEK/S	2305499	1
CABLE-D37SUB/B/B/ 100/KONFEK/S	2305509	1
CABLE-D37SUB/B/B/ 200/KONFEK/S	2305512	1
CABLE-D37SUB/B/B/ 300/KONFEK/S	2305525	1
CABLE-D37SUB/B/B/ 400/KONFEK/S	2900759	1
CABLE-D37SUB/B/B/ 600/KONFEK/S	2900760	1
CABLE-D37SUB/B/B/ 800/KONFEK/S	2900761	1
CABLE-D37SUB/B/B/1000/KONFEK/S	2900762	1
CABLE-D37SUB/B/B/1500/KONFEK/S	2900763	1
CABLE-D37SUB/B/B/2000/KONFEK/S	2900764	1
CABLE-D50SUB/B/B/100/KONFEK/S	2305541	1
CABLE-D50SUB/B/B/200/KONFEK/S	2305554	1
CABLE-D50SUB/B/B/300/KONFEK/S	2305567	1

Ordering data		
Type	Order No.	Pcs./ Pkt.
CABLE-D 9SUB/S/S/100/KONFEK/S	2305570	1
CABLE-D 9SUB/S/S/200/KONFEK/S	2305583	1
CABLE-D 9SUB/S/S/300/KONFEK/S	2305596	1
CABLE-D15SUB/S/S/100/KONFEK/S	2305606	1
CABLE-D15SUB/S/S/200/KONFEK/S	2305619	1
CABLE-D15SUB/S/S/300/KONFEK/S	2305622	1
CABLE-D25SUB/S/S/100/KONFEK/S	2305635	1
CABLE-D25SUB/S/S/200/KONFEK/S	2305648	1
CABLE-D25SUB/S/S/300/KONFEK/S	2305651	1
CABLE-D37SUB/S/S/100/KONFEK/S	2305664	1
CABLE-D37SUB/S/S/200/KONFEK/S	2305677	1
CABLE-D37SUB/S/S/300/KONFEK/S	2305680	1
CABLE-D50SUB/S/S/100/KONFEK/S	2305693	1
CABLE-D50SUB/S/S/200/KONFEK/S	2305703	1
CABLE-D50SUB/S/S/300/KONFEK/S	2305716	1

Ordering data		
Type	Order No.	Pcs./ Pkt.
CABLE-D37SUB/B/B/HF/S/ 1,0M	2908516	1
CABLE-D37SUB/B/B/HF/S/ 2,0M	2908517	1
CABLE-D37SUB/B/B/HF/S/ 3,0M	2908518	1
CABLE-D37SUB/B/B/HF/S/ 4,0M	2908519	1
CABLE-D37SUB/B/B/HF/S/ 6,0M	2908520	1
CABLE-D37SUB/B/B/HF/S/ 8,0M	2908521	1
CABLE-D37SUB/B/B/HF/S/10,0M	2908522	1
CABLE-D37SUB/B/B/HF/S/15,0M	2908523	1
CABLE-D37SUB/B/B/HF/S/20,0M	2908525	1

System cabling for controllers

Universal cables

System cables with D-SUB socket and pin strips

Special lengths

Pre-assembled, shielded **round cables** for connecting VARIOFACE termination boards. The cables are assembled with D-SUB strips according to IEC 60807-2/DIN 41652.

The order key is described using three features.

The order of the features is as follows:

- Cable type
- Assembly
- Length in meters

There are three assembly versions for the shielded round cable:

- CABLE D-SUB-S/.../.../...
D-SUB socket strip at one end and D-SUB pin strip at the other end,
- CABLE D-SUB-B-B-S/.../.../...
D-SUB socket strips at both ends,
- CABLE D-SUB-S-S/.../.../...

D-SUB pin strips at both ends
To ensure clear specification when ordering, the features are described in detail below:

Cable type

- This specifies the number of individual cables of the specific cable.

Assembly

- (Example for CABLE D-SUB-S/.../.../...)
- None, the cable is not assembled at either end,
- 9-pos. D-SUB socket strip at one end, 9-pos. D-SUB pin strip at the other end, the cable connects (1:1) a 9-pos. D-SUB socket and pin strip,
- 15-pos. D-SUB socket strip at one end, 15-pos. D-SUB pin strip at the other end, the cable connects (1:1) a 15-pos. D-SUB socket and pin strip, etc. to

- 50-pos. D-SUB socket strip at one end, 50-pos. D-SUB pin strip at the other end, the cable connects (1:1) a 50-pos. D-SUB socket and pin strip.

Ordering example for round cable assembled with pin strip at one end and socket strip at the other end

– shielded 25-pos. round cable, assembled with a 25-pos. D-SUB socket strip and a 25-pos. D-SUB pin strip, 11.5 mm long

Quantity	Order No.	Cable type	Assembly	Length [m] ¹⁾
1	2302340	25S 09S ≙ 9-pos. shielded 15S ≙ 15-pos. shielded 25S ≙ 25-pos. shielded 37S ≙ 37-pos. shielded 50S ≙ 50-pos. shielded	C36 C00 ≙ No assembly C01 ≙ 9-pos. D-SUB socket strip at one end 9-pos. D-SUB pin strip at the other end C28 ≙ 15-pos. D-SUB socket strip at one end 15-pos. D-SUB pin strip at the other end C36 ≙ 25-pos. D-SUB socket strip at one end 25-pos. D-SUB pin strip at the other end C43 ≙ 37-pos. D-SUB socket strip at one end 37-pos. D-SUB pin strip at the other end C49 ≙ 50-pos. D-SUB socket strip at one end 50-pos. D-SUB pin strip at the other end	11.50 ¹⁾ min. 0.20 m

Ordering example for round cable assembled with socket strip at both ends

– shielded 37-pos. round cable, assembled with two D-SUB 37 socket strips, 12.75 m long

Quantity	Order No.	Cable type	Assembly	Length [m] ¹⁾
1	2302421	37S 09S ≙ 9-pos. shielded 15S ≙ 15-pos. shielded 25S ≙ 25-pos. shielded 37S ≙ 37-pos. shielded 50S ≙ 50-pos. shielded	C44 C00 ≙ No assembly C22 ≙ 9-pos. D-SUB socket strip at both ends C29 ≙ 15-pos. D-SUB socket strip at both ends C37 ≙ 25-pos. D-SUB socket strip at both ends C44 ≙ 37-pos. D-SUB socket strip at both ends C50 ≙ 50-pos. D-SUB socket strip at both ends	12.75 ¹⁾ min. 0.20 m

Ordering example for round cable assembled with pin strip at both ends

– shielded 15-pos. round cable, assembled with two D-SUB 15 pin strips, 8.5 m long

Quantity	Order No.	Cable type	Assembly	Length [m] ¹⁾
1	2302434	15S 09S ≙ 9-pos. shielded 15S ≙ 15-pos. shielded 25S ≙ 25-pos. shielded 37S ≙ 37-pos. shielded 50S ≙ 50-pos. shielded	C71 C00 ≙ No assembly C70 ≙ 9-pos. D-SUB pin strip at both ends C71 ≙ 15-pos. D-SUB pin strip at both ends C72 ≙ 25-pos. D-SUB pin strip at both ends C73 ≙ 37-pos. D-SUB pin strip at both ends C74 ≙ 50-pos. D-SUB pin strip at both ends	8.50 ¹⁾ min. 0.20 m



Shielded



Technical data

Maximum permissible operating voltage	25 V AC / 60 V DC
Maximum permissible operating voltage UL / CSA	125 V / 125 V
Maximum permissible current carrying capacity per path	2 A
Maximum conductor resistance	0.09 Ω/m
Ambient temperature (operation)	-20 °C ... 50 °C
Shield	Tinned copper-braided shield, approx. 85% covering
Insertion/withdrawal cycles	> 200
Conductor cross section	AWG 24 / 0.25 mm ²

Ordering data

Description	No. of pos.	Cable length	Type	Order No.	Pcs./ Pkt.
Assembled round cable, in variable lengths, pin strip at one end and socket strip at the other end					
	9		CABLE D-SUB-S/.../.../...	2302340	1
Assembled round cable, in variable lengths, socket strip at both ends					
	9		CABLE D-SUB-B-B-S/.../.../...	2302421	1
Assembled round cable, in variable lengths, pin strip at both ends					
	9		CABLE D-SUB-S-S-S/.../.../...	2302434	1

System cabling for controllers

Universal cables

System cable with D-SUB socket strip or pin strip and an open end

- 1:1 connection
- D-SUB socket strip or pin strip at one end
- Connector according to IEC 60807-2/DIN 41652
- Gland: 2 UNC 4-40 screws
- Open end at the other end
- Individual wire marking: 1, 2, 3, 4, etc.
- Individual wires fitted with ferrules
- Shield connection: H05V-K 1 mm² cable, black, 0.5 m in length



Socket strip at one end and open end at the other end



Pin strip at one end and open end at the other end



Technical data

Maximum permissible operating voltage	25 V AC / 60 V DC
Maximum permissible operating voltage UL / CSA	125 V / 125 V
Maximum permissible current carrying capacity per path	2 A
Maximum conductor resistance	0.09 Ω/m
Ambient temperature (operation)	-20 °C ... 50 °C
Shield	Tinned copper-braided shield, approx. 85% covering
Insertion/withdrawal cycles	> 200
Conductor cross section	AWG 24 / 0.25 mm ²
Outside diameter	9-pos. 7.5 mm 15-pos. 9 mm 25-pos. 10.5 mm

Technical data

Maximum permissible operating voltage	25 V AC / 60 V DC
Maximum permissible operating voltage UL / CSA	125 V / 125 V
Maximum permissible current carrying capacity per path	2 A
Maximum conductor resistance	0.09 Ω/m
Ambient temperature (operation)	-20 °C ... 50 °C
Shield	Tinned copper-braided shield, approx. 85% covering
Insertion/withdrawal cycles	> 200
Conductor cross section	AWG 24 / 0.25 mm ²
Outside diameter	7.5 mm 9 mm 10.5 mm

Ordering data

Description	No. of pos.	Cable length	Type	Order No.	Pcs./ Pkt.
Round cable with an open end					
	9	0.5 m	CABLE-D- 9SUB/F/OE/0,25/S/0,5M	2926014	1
	9	1 m	CABLE-D- 9SUB/F/OE/0,25/S/1,0M	2926027	1
	9	1.5 m	CABLE-D- 9SUB/F/OE/0,25/S/1,5M	2926030	1
	9	2 m	CABLE-D- 9SUB/F/OE/0,25/S/2,0M	2926043	1
	9	3 m	CABLE-D- 9SUB/F/OE/0,25/S/3,0M	2926056	1
	9	4 m	CABLE-D- 9SUB/F/OE/0,25/S/4,0M	2926069	1
	9	6 m	CABLE-D- 9SUB/F/OE/0,25/S/6,0M	2926072	1
Round cable, as above, but in variable lengths					
	9		CABLE-D- 9SUB-F-OE-0,25-S/...	2900903	1
Round cable with an open end					
	15	0.5 m	CABLE-D-15SUB/F/OE/0,25/S/0,5M	2926085	1
	15	1 m	CABLE-D-15SUB/F/OE/0,25/S/1,0M	2926098	1
	15	1.5 m	CABLE-D-15SUB/F/OE/0,25/S/1,5M	2926108	1
	15	2 m	CABLE-D-15SUB/F/OE/0,25/S/2,0M	2926111	1
	15	3 m	CABLE-D-15SUB/F/OE/0,25/S/3,0M	2926124	1
	15	4 m	CABLE-D-15SUB/F/OE/0,25/S/4,0M	2926137	1
	15	6 m	CABLE-D-15SUB/F/OE/0,25/S/6,0M	2926140	1
Round cable, as above, but in variable lengths					
	15		CABLE-D-15SUB-F-OE-0,25-S/...	2900905	1
Round cable with an open end					
	25	0.5 m	CABLE-D-25SUB/F/OE/0,25/S/0,5M	2926153	1
	25	1 m	CABLE-D-25SUB/F/OE/0,25/S/1,0M	2926166	1
	25	1.5 m	CABLE-D-25SUB/F/OE/0,25/S/1,5M	2926179	1
	25	2 m	CABLE-D-25SUB/F/OE/0,25/S/2,0M	2926182	1
	25	3 m	CABLE-D-25SUB/F/OE/0,25/S/3,0M	2926195	1
	25	4 m	CABLE-D-25SUB/F/OE/0,25/S/4,0M	2926205	1
	25	6 m	CABLE-D-25SUB/F/OE/0,25/S/6,0M	2926218	1
Round cable, as above, but in variable lengths					
	25		CABLE-D-25SUB-F-OE-0,25-S/...	2900906	1

Ordering data

Description	No. of pos.	Cable length	Type	Order No.	Pcs./ Pkt.
Round cable with an open end					
	9	0.5 m	CABLE-D- 9SUB/M/OE/0,25/S/0,5M	2926360	1
	9	1 m	CABLE-D- 9SUB/M/OE/0,25/S/1,0M	2926373	1
	9	1.5 m	CABLE-D- 9SUB/M/OE/0,25/S/1,5M	2926386	1
	9	2 m	CABLE-D- 9SUB/M/OE/0,25/S/2,0M	2926399	1
	9	3 m	CABLE-D- 9SUB/M/OE/0,25/S/3,0M	2926409	1
	9	4 m	CABLE-D- 9SUB/M/OE/0,25/S/4,0M	2926412	1
	9	6 m	CABLE-D- 9SUB/M/OE/0,25/S/6,0M	2926425	1
Round cable, as above, but in variable lengths					
	9		CABLE-D- 9SUB-M-OE-0,25-S/...	2900909	1
Round cable with an open end					
	15	0.5 m	CABLE-D-15SUB/M/OE/0,25/S/0,5M	2926438	1
	15	1 m	CABLE-D-15SUB/M/OE/0,25/S/1,0M	2926441	1
	15	1.5 m	CABLE-D-15SUB/M/OE/0,25/S/1,5M	2926454	1
	15	2 m	CABLE-D-15SUB/M/OE/0,25/S/2,0M	2926467	1
	15	3 m	CABLE-D-15SUB/M/OE/0,25/S/3,0M	2926470	1
	15	4 m	CABLE-D-15SUB/M/OE/0,25/S/4,0M	2926483	1
	15	6 m	CABLE-D-15SUB/M/OE/0,25/S/6,0M	2926496	1
Round cable, as above, but in variable lengths					
	15		CABLE-D-15SUB-M-OE-0,25-S/...	2900910	1
Round cable with an open end					
	25	0.5 m	CABLE-D-25SUB/M/OE/0,25/S/0,5M	2926506	1
	25	1 m	CABLE-D-25SUB/M/OE/0,25/S/1,0M	2926519	1
	25	1.5 m	CABLE-D-25SUB/M/OE/0,25/S/1,5M	2926522	1
	25	2 m	CABLE-D-25SUB/M/OE/0,25/S/2,0M	2926535	1
	25	3 m	CABLE-D-25SUB/M/OE/0,25/S/3,0M	2926548	1
	25	4 m	CABLE-D-25SUB/M/OE/0,25/S/4,0M	2926551	1
	25	6 m	CABLE-D-25SUB/M/OE/0,25/S/6,0M	2926564	1
Round cable, as above, but in variable lengths					
	25		CABLE-D-25SUB-M-OE-0,25-S/...	2900911	1

Special lengths of D-SUB cable with open ends are configured using separate order numbers.

Ordering example:

One system cable assembled with a 37-pos. D-SUB socket strip and an open end, 12.75 m in length:

1 pcs. 2900907/12,75



Socket strip at one end and open end at the other end



Pin strip at one end and open end at the other end



Technical data

Maximum permissible operating voltage	25 V AC / 60 V DC
Maximum permissible operating voltage UL / CSA	125 V / 125 V
Maximum permissible current carrying capacity per path	2 A
Maximum conductor resistance	0.09 Ω/m
Ambient temperature (operation)	-20 °C ... 50 °C
Shield	Tinned copper-braided shield, approx. 85% covering
Insertion/withdrawal cycles	> 200
Conductor cross section	AWG 24 / 0.25 mm ²
Outside diameter	37-pos. 12 mm 50-pos. 13.5 mm



Technical data

Maximum permissible operating voltage	25 V AC / 60 V DC
Maximum permissible operating voltage UL / CSA	125 V / 125 V
Maximum permissible current carrying capacity per path	2 A
Maximum conductor resistance	0.09 Ω/m
Ambient temperature (operation)	-20 °C ... 50 °C
Shield	Tinned copper-braided shield, approx. 85% covering
Insertion/withdrawal cycles	> 200
Conductor cross section	AWG 24 / 0.25 mm ²
Outside diameter	12 mm 13.5 mm

Ordering data

Description	No. of pos.	Cable length	Type	Order No.	Pcs./ Pkt.
Round cable with an open end	37	0.5 m	CABLE-D-37SUB/F/OE/0,25/S/0,5M	2926221	1
	37	1 m	CABLE-D-37SUB/F/OE/0,25/S/1,0M	2926234	1
	37	1.5 m	CABLE-D-37SUB/F/OE/0,25/S/1,5M	2926247	1
	37	2 m	CABLE-D-37SUB/F/OE/0,25/S/2,0M	2926250	1
	37	3 m	CABLE-D-37SUB/F/OE/0,25/S/3,0M	2926263	1
	37	4 m	CABLE-D-37SUB/F/OE/0,25/S/4,0M	2926276	1
	37	6 m	CABLE-D-37SUB/F/OE/0,25/S/6,0M	2926289	1
Round cable, as above, but in variable lengths	37		CABLE-D-37SUB-F-OE-0,25-S/...	2900907	1
Round cable with an open end	50	0.5 m	CABLE-D-50SUB/F/OE/0,25/S/0,5M	2926292	1
	50	1 m	CABLE-D-50SUB/F/OE/0,25/S/1,0M	2926302	1
	50	1.5 m	CABLE-D-50SUB/F/OE/0,25/S/1,5M	2926315	1
	50	2 m	CABLE-D-50SUB/F/OE/0,25/S/2,0M	2926328	1
	50	3 m	CABLE-D-50SUB/F/OE/0,25/S/3,0M	2926331	1
	50	4 m	CABLE-D-50SUB/F/OE/0,25/S/4,0M	2926344	1
	50	6 m	CABLE-D-50SUB/F/OE/0,25/S/6,0M	2926357	1
Round cable, as above, but in variable lengths	50		CABLE-D-50SUB-F-OE-0,25-S/...	2900908	1

Ordering data

Description	No. of pos.	Cable length	Type	Order No.	Pcs./ Pkt.
Round cable with an open end	37	0.5 m	CABLE-D-37SUB/M/OE/0,25/S/0,5M	2926577	1
	37	1 m	CABLE-D-37SUB/M/OE/0,25/S/1,0M	2926580	1
	37	1.5 m	CABLE-D-37SUB/M/OE/0,25/S/1,5M	2926593	1
	37	2 m	CABLE-D-37SUB/M/OE/0,25/S/2,0M	2926603	1
	37	3 m	CABLE-D-37SUB/M/OE/0,25/S/3,0M	2926616	1
	37	4 m	CABLE-D-37SUB/M/OE/0,25/S/4,0M	2926629	1
	37	6 m	CABLE-D-37SUB/M/OE/0,25/S/6,0M	2926632	1
Round cable, as above, but in variable lengths	37		CABLE-D-37SUB-M-OE-0,25-S/...	2900912	1
Round cable with an open end	50	0.5 m	CABLE-D-50SUB/M/OE/0,25/S/0,5M	2926645	1
	50	1 m	CABLE-D-50SUB/M/OE/0,25/S/1,0M	2926658	1
	50	1.5 m	CABLE-D-50SUB/M/OE/0,25/S/1,5M	2926661	1
	50	2 m	CABLE-D-50SUB/M/OE/0,25/S/2,0M	2926674	1
	50	3 m	CABLE-D-50SUB/M/OE/0,25/S/3,0M	2926687	1
	50	4 m	CABLE-D-50SUB/M/OE/0,25/S/4,0M	2926690	1
	50	6 m	CABLE-D-50SUB/M/OE/0,25/S/6,0M	2926700	1
Round cable, as above, but in variable lengths	50		CABLE-D-50SUB-M-OE-0,25-S/...	2900913	1

System cabling for controllers

Potential distributors

Modules as compact potential distributors

The VIP-2/.../PDM... modules offer the following features:

- Two potential levels
- Separate supply
- Screw or Push-in connection
- Consecutive marking
- With fuse as an option

The UMK-PVB and UMK-PVB 6 modules have three or six potential levels.

Notes:
Marking systems and mounting material See Catalog 3
1) No UL approval



With screw connection and 2 potential levels



With Push-in connection and 2 potential levels

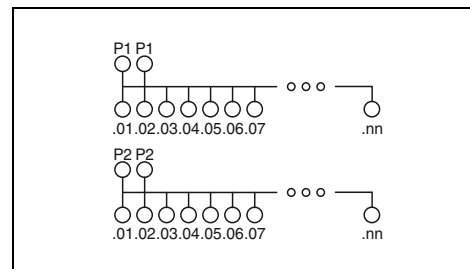
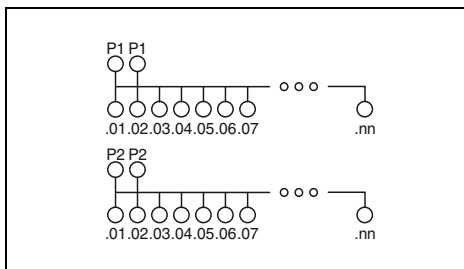

Technical data

Maximum permissible operating voltage
Maximum permissible operating voltage UL / CSA

250 V AC/DC
250 V / 250 V

Maximum permissible current (per branch)
Total current
Ambient temperature (operation)
Mounting position
Standards/regulations
Supply connection data solid/stranded/AWG

15 A
30 A (per potential)
-20 °C ... 50 °C
any
IEC 60664 , DIN EN 50178
0.2 - 6 mm² / 0.2 - 4 mm² / 24 - 10

Distribution connection data solid/stranded/AWG

0.2 - 4 mm² / 0.2 - 2.5 mm² / 24 - 12

Dimensions

H / D

65.5 mm / 50 mm

Technical data

250 V AC/DC
250 V / 250 V

15 A
30 A (per potential)
-20 °C ... 50 °C
any
IEC 60664 , DIN EN 50178
0.25 - 6 mm² / 0.25 - 4 mm² / 24 - 10

0.14 - 2.5 mm² / 0.14 - 2.5 mm² / 26 - 14

75.8 mm / 63 mm

Ordering data

Description	No. of pos.	Module width W
VARIOFACE module , with two busbars (P1, P2) for potential distribution, per potential:		
2 power terminals/8 distributor terminal blocks		50.00
2 power terminals/12 distributor terminal blocks		70.40
2 power terminals/16 distributor terminal blocks		90.80
2 power terminals/24 distributor terminal blocks		131.50
VARIOFACE module , with two busbars (P1, P2) for potential distribution, per potential:		
2 power terminals/8 distributor terminal blocks		41.90
2 power terminals/12 distributor terminal blocks		57.10
2 power terminals/16 distributor terminal blocks		67.30
2 power terminals/24 distributor terminal blocks		97.70
VARIOFACE module with 2 busbars for potential distribution		
- 2 power terminals/8 distributor blocks		97.70
VARIOFACE module , with three busbars (+, -, PE) for potential distribution, per potential:		
(+) 2 power terminals/48 distributor terminal blocks		168.80
(-) 2 power terminals/24 distributor terminal blocks		
(PE) 2 power terminals/72 distributor terminal blocks		
VARIOFACE module , with six busbars (P1 to P6) for potential distribution, per potential:		
2 power terminals/12 distributor terminal blocks		123.80

Type	Order No.	Pcs./ Pkt.
VIP-2/SC/PDM-2/16	2315256	1
VIP-2/SC/PDM-2/24	2315269	1
VIP-2/SC/PDM-2/32	2315272	1
VIP-2/SC/PDM-2/48 ¹⁾	2903717	1

Ordering data

Type	Order No.	Pcs./ Pkt.
VIP-3/PT/PDM-2/16	2903797	1
VIP-3/PT/PDM-2/24	2903798	1
VIP-3/PT/PDM-2/32	2903799	1
VIP-3/PT/PDM-2/48	2903800	1



With Push-in connection and 2 potential levels and eight 6.3 A fuses

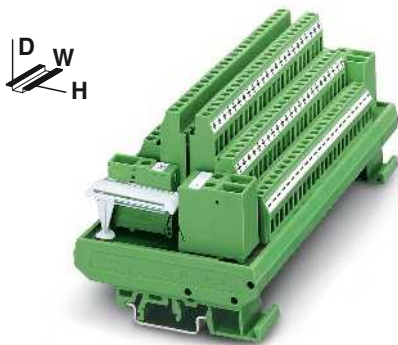

With screw connection and 3 potential levels

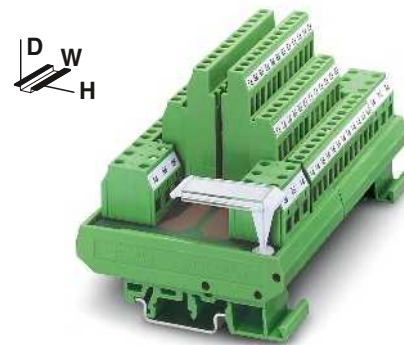

With screw connection and 6 potential levels

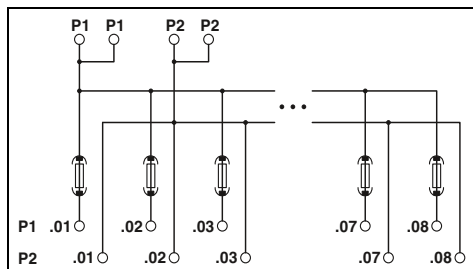

Technical data

250 V AC/DC
250 V / 250 V

6.3 A (fuse limited)
30 A (per potential)
-20 °C ... 60 °C

any
IEC 60664 , DIN EN 50178
0.2 - 10 mm² / 0.2 - 6 mm² / 24 - 8

0.14 - 2.5 mm² / 0.14 - 2.5 mm² / 26 - 14

109.8 mm / 51 mm

Ordering data

Type	Order No.	Pcs./ Pkt.
VIP-2/PT/PDM-2/16/FU 6.3A	2903603	1

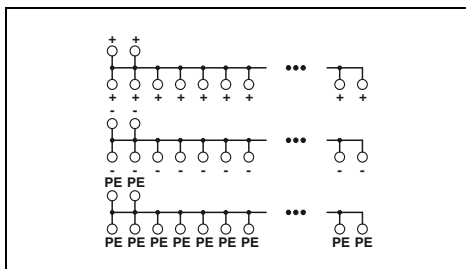

Technical data

250 V AC/DC
- / -

16 A
16 A (per potential)
-20 °C ... 50 °C

any
IEC 60664 , DIN EN 50178
0.5 - 6 mm² / 0.5 - 4 mm² / 20 - 10

0.2 - 4 mm² / 0.2 - 2.5 mm² / 24 - 12

77 mm / 72 mm

Ordering data

Type	Order No.	Pcs./ Pkt.
UMK- PVB	2971302	1

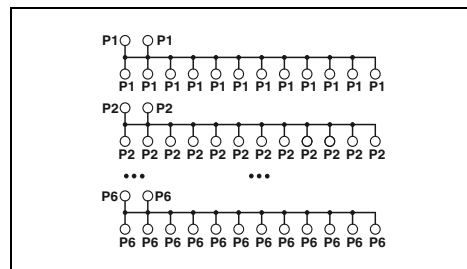

Technical data

250 V AC/DC
- / -

16 A
16 A (per potential)
-20 °C ... 50 °C

any
IEC 60664 , DIN EN 50178
0.2 - 6 mm² / 0.2 - 4 mm² / 24 - 10

0.2 - 4 mm² / 0.2 - 2.5 mm² / 24 - 12

77 mm / 72 mm

Ordering data

Type	Order No.	Pcs./ Pkt.
UMK- PVB 6	2972136	1

System cabling for controllers

Tables, dimensional drawings

Modules for ELCO connectors

Dimensional drawing for UMK-EC38/38-XOL

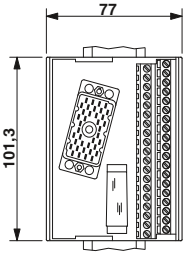

Dimensional drawing for UMK-EC38/38-XOR

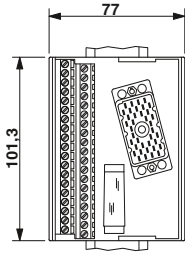

Dimensional drawing for UMK-EC56/56-XOL

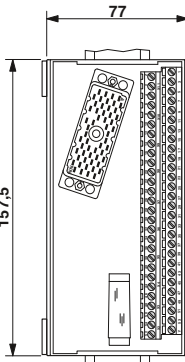

Dimensional drawing for UMK-EC56/56-XOR

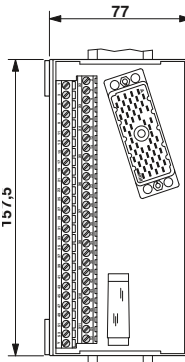

Dimensional drawing for UMK-EC56/FRONT 2,5V/R

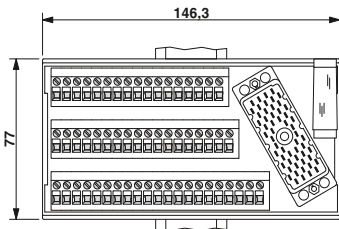

Dimensional drawing for UMK-EC56/FRONT 2,5V/L

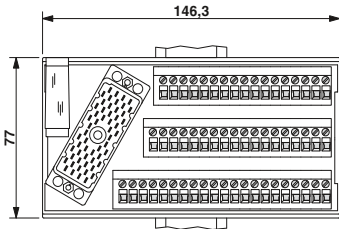

Dimensional drawing for UMK-EC56/32-XOL

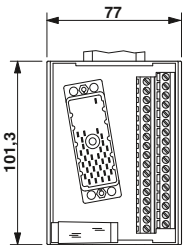

Dimensional drawing for UMK-EC56/32-XOR

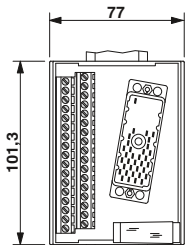

Pin assignment UMK-EC38/38...

Terminal block	Pin strip
1	A
2	B
3	C
4	D
5	E
6	F
7	H
8	J
9	K
10	L
11	M
12	N
13	P
14	R
15	S
16	T
17	U
18	V
19	W
20	X
21	Y
22	Z
23	AA
24	BB
25	DD
26	EE
27	FF
28	HH
29	JJ
30	KK
31	LL
32	MM
33	NN
34	PP
35	RR
36	SS
37	TT
CC	CC

Pin assignment UMK-EC56/56...

Terminal block	Pin strip
Z	Z
1	A
2	B
3	C
4	D
5	E
6	F
7	H
8	J
9	K
10	L
11	M
12	N
13	P
14	R
15	S
16	T
17	U
18	V
19	W
20	X
21	a
22	b
23	c
24	d
25	e
26	f
27	h
28	j
29	k
30	l
31	m
32	n
33	p
34	r
35	s
36	t
37	u
38	v
39	w
40	x
41	y
42	z
43	AA
44	BB
45	CC
46	DD
47	EE
48	FF
49	HH
50	JJ
51	KK
52	LL
53	MM
54	NN
Y	Y (shield)

Pin assignment UMK-EC56/FRONT 2,5V/...

Terminal block	ELCO connector
X	N.C.
1	A
2	B
3	C
4	D
5	E
6	F
7	H
8	J
9	K
10	L
11	M
12	N
13	P
14	R
15	S
16	T
17	U
18	V
19	W
20	X
21	a
22	b
23	c
24	d
25	e
26	f
27	h
28	j
29	k
30	l
31	m
32	n
33	p
34	r
35	s
36	t
37	u
38	v
39	w
40	x
41	y
42	z
43	AA
44	BB
45	CC
46	DD
47	EE
48	FF
49	HH
50	JJ
51	KK
52	LL
53	MM
54	NN
Y	Y (shield)

Pin assignment UMK-EC56/32-...

Terminal block	ELCO connector
1	A
2	B
3	C
4	D
5	E
6	F
7	H
8	J
9	K
10	L
11	M
12	N
13	P
14	R
15	S
16	T
17	U
18	V
19	W
20	X
21	Z
22	a
23	b
24	c
25	d
26	e
27	f
28	h
29	j
30	k
31	l
32	m
Y	NN + Y

Modules for ELCO connectors with Ex i protection

Dimensional drawing for UMK-EC90/32/EX-XUL

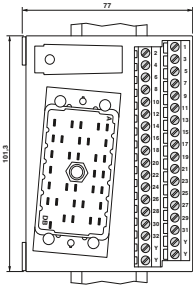

Dimensional drawing for UMK-EC90/32/EX-XUR

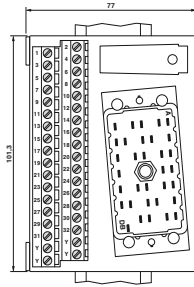

Dimensional drawing for UMK-EC56/25/EX-L

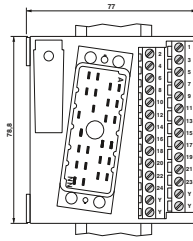

Dimensional drawing for UMK-EC56/25/EX-R

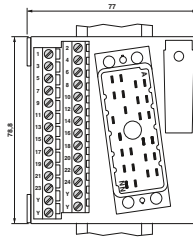

Dimensional drawing for UMK-EC90/32/EX-XOL

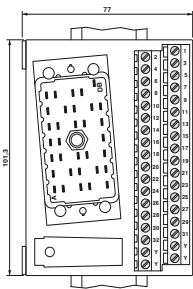

Dimensional drawing for UMK-EC90/32/EX-XOR

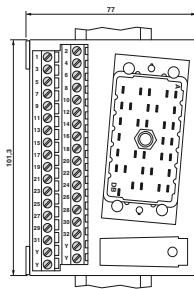

Dimensional drawing for UMK-EC 56/25/EX/FRONT 2,5 V/L

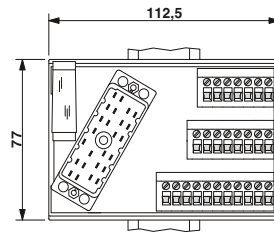

Pin assignment UMK-EC90/32/EX...

Terminal block	Pin strip	Channel
1	H	1
2	J	1
3	L	2
4	M	2
5	P	3
6	X	3
7	Z	4
8	AA	4
9	AC	5
10	AD	5
11	AM	6
12	AN	6
13	AR	7
14	AS	7
15	AU	8
16	BC	8
17	AZ	9
18	BA	9
19	BJ	10
20	BK	10
21	BM	11
22	BN	11
23	BR	12
24	BY	12
25	CA	13
26	CB	13
27	CD	14
28	CE	14
29	CN	15
30	CP	15
31	CS	16
32	CT	16
Y	DB	

Dimensional drawing for UMK-EC 56/25/EX/FRONT 2,5 V/R

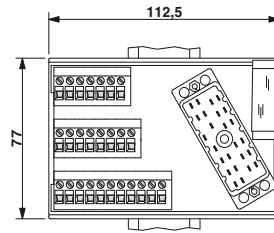

Pin assignment UMK-EC 56/25/EX/...

Terminal block	Pin strip	Channel
1	C	1
2	D	1
3	E	2
4	F	2
5	N	3
6	P	3
7	R	4
8	S	4
9	a	5
10	b	5
11	d	6
12	j	6
13	k	7
14	l	7
15	s	8
16	t	8
17	u	9
18	v	9
19	BB	10
20	CC	10
21	DD	11
22	EE	11
23	MM	12
24	NN	12
Y	Y	

Quality in quantity

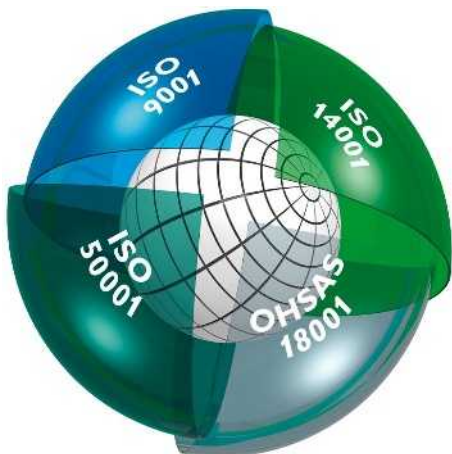

Integrated management system

The objective of the Phoenix Contact integrated management system is to integrate all requirements pertaining to products, processes, and the organization.

Statutory and regulatory requirements, as well as those of international standards and our customers, are met and, in some cases, even exceeded in all phases of the product lifecycle.

The Phoenix Contact management system is monitored by internationally recognized independent bodies each year to ensure that quality, environmental protection, energy efficiency, and occupational safety have been integrated in conformance with the relevant requirements. Certification in accordance with international standards ISO 9001, ISO 14001, ISO 50001, and BS OHSAS 18001 is the result of our corporate philosophy of meeting the needs of our customers, staff, and environment as best as possible. They serve as the basis for innovative products with the familiar high Phoenix quality standard, actively practiced environmental protection through efficient production and products that conserve resources, and responsibility in the field of occupational health and safety. It goes without saying that we integrate all further requirements of standards, international approvals or special customer requirements into our company processes.

The result of this system is a building block for the success of the Phoenix Contact Group as well as its products and services.

CE marking

CE marking was introduced as an important instrument for the free movement of goods within the European single market. By applying the mark to a product, the manufacturer confirms its compliance with all EU directives applicable to this product. The EU directives describe

the product characteristics with regard to device safety and the avoidance of risks. These are legally binding regulations of the European Union (EU), which means that the fulfillment of these requirements is a **legal prerequisite for the marketing of these products within the EU.**

Where applicable, our products currently fall within the scope of the following directives:

- 2014/35/EU
Electrical equipment designed for use within certain voltage limits (Low Voltage Directive)
- 2014/30/EU
Electromagnetic compatibility (EMC Directive)
- 2014/32/EU
Measuring instruments
- 2006/42/EC
Safety of machinery (Machinery Directive)
- 2014/34/EU
Equipment and protective systems intended for use in potentially explosive atmospheres (ATEX Directive)
- 1999/5/EC
Radio Equipment and Telecommunications Terminal Equipment Directive (R&TTE)
- 2014/53/EU
Radio equipment (RED)
- 2011/65/EU
RoHS Directive

The standards used as the basis for the aforementioned directives have been at the heart of our development standard for some time as a way of ensuring compliance with European directives. The numbers of the directives indicate their version at the time of publication. In the event of changes to directives and/or standards, our products will undergo conformity assessment again in good time and a new declaration of conformity will be issued promptly. The current declarations for each product can also be found in our download area.

Among the aforementioned European directives, the EMC Directive plays a particularly important role. It uses a legally binding directive as the basis for defining electromagnetic compatibility as a fundamental device property. European legislation therefore places great emphasis on the electromagnetic compatibility of devices and systems as a basic prerequisite for the error-free operation of machines and systems. As an international leader in the field of surge protection, Phoenix Contact has extensive expertise in EMC. This expertise and the experience gained over many years in the development and application of industrial interface and

communication technology have resulted in an extremely high standard of quality for our products when it comes to electromagnetic compatibility. Our sister company, Phoenix Testlab, was founded in order to share this expertise with other companies. Phoenix Testlab GmbH is an independent, accredited service company, which carries out EMC testing in compliance with the European standards. At Phoenix Testlab, devices are also tested with regard to their electrical safety, mechanical influences, and their behavior in relation to environmental influences. Phoenix Testlab is also a notified body according to EMC Directive 2014/30/EU, R&TTE Directive 1999/5/EC for radio equipment and telecommunications terminal equipment, and Radio Equipment Directive (RED) 2014/53/EU. As a certification body (TCB, FCB, and RCB), Phoenix Testlab is also able to approve these products for the markets in the USA, Canada, and Japan.

Standards and regulations

All relevant standards and regulations are used as the basis for the development and maintenance of our products.

International standards are subject to continuous changes as a result of harmonization and new developments. In line with this process, the current version of all standards that are relevant to our products is documented in the product area on our website at

phoenixcontact.net/products.

Online product information service on the world wide web

Phoenix Contact is continuously extending its product range.

Within the scope of our product monitoring obligation, all products are subject to an improvement process.

The Internet is an ideal platform to quickly communicate new product developments and improvements to the market.

You can quickly access the relevant Phoenix Contact website for your region via phoenixcontact.com. There you will always find an up-to-date overview of products, solutions, and services from Phoenix Contact. This includes technical documents such as data sheets and user manuals, current driver and demo software, and a direct link to the relevant contact person.

Touch proofness

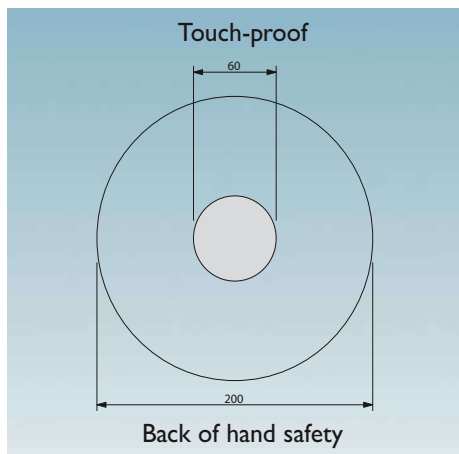

Example: pressure actuation



Finger safety



Back of hand safety

The accident prevention regulations BGV A 2 issued by the German employer's liability insurance association for precision mechanics and electrical engineering apply to the operators of electrical systems and are aimed at the prevention of electrical accidents by means of special safety requirements.

These regulations contain specifications regarding the safety distances for work, operation, and occasional handling in the proximity of "live parts" in low-voltage systems up to 1000 V ~ or 1500 V –.

- Work with live parts is only permitted once they have been de-energized.

Operational activities are only permitted in the vicinity of live parts if these parts are de-energized or are protected against direct contact (§ 6). The following safety measures apply when working in the vicinity of live parts:

- Provision of the de-energized state for the duration of the work
- Ensure shock protection is in place in the form of covers or barriers during the work
- Assurance that proximity limits will not be violated (§ 7)

The term "occasional handling" has been introduced for the operation of elements such as pushbuttons, rocker arms or rotary buttons in the proximity of live parts.

In VDE 0105-1, this is covered by "operation with partial protection against direct contact".

Detailed specifications for "occasional handling" can be found in DIN VDE 0106-100. This specifies to what degree live parts in the proximity of operating elements are to be protected against contact. The basis for this is the definition of a "protection area for occasional handling"; this is the area into which the user must reach in order to handle the machine.

The most important thing is that an area formed by an even envelope curve 30 mm in radius must surround the live parts. This area must be **touch-proof**, i.e., the live parts of the electrical device must not be within reach of the VDE test finger according to IEC 60529/DIN VDE 0470-1 (test finger).

Back of hand safety is specified for the "rest of the area" up to 100 mm around the operating element. **Back of hand safety** means that when a force of 50 N is applied to a ball with a diameter of 50 mm, this does not come into contact with the live parts of the equipment. No special measures for ensuring contact safety are stipulated outside this area.

Note: Systems and equipment that are operated with SELV up to 25 V ~ or 60 V – are considered to be protected against "direct contact".

According to § 5, Subsection 4 of the BGV A 2 regulations, there is no need to test the condition of the system prior to initial startup if the company has confirmation from the manufacturer or installer that the electrical systems and equipment conform to BGV A 2. The confirmation required relates to systems and equipment that have been installed and are ready for operation and can only be issued by the installer or installation company. The manufacturer of the electrical equipment can only issue a confirmation that products have been produced in accordance with the relevant electrotechnical DIN VDE regulations stipulated in BGV A 2. The installer must bear this in mind when selecting the equipment to be used.

In the field of connection technology, Phoenix Contact offers a wide range of products which are touch-proof or can be protected against contact by means of

covers. Depending on the conditions, all of this must be taken into account when selecting the individual types of terminal blocks and accessories.

Quality features of insulating housings

Thermoplastics

The majority of our insulating housing is made from thermoplastic materials. Roughly speaking, these can be divided into amorphous and semi-crystalline substances. Thermoplastics are processed using the efficient and environmentally-friendly injection molding process. They have good recycling properties and can be re-used. We use many materials that are modified in different ways to meet the demanding requirements that electrical and electronic modules, devices, and systems have to meet with regard to their mechanical, thermal, and electrical properties.

Behavior of plastics under the influence of temperature (operating temperatures, mechanical influences)

All plastics undergo a process referred to as thermal aging when they are subjected to heat over long periods. This process causes changes in the mechanical and electrical properties of the material. External influences, e.g., radiation, additional mechanical, chemical or electrical stresses, amplify this effect. Special tests on samples can yield characteristic data which provides a good means of drawing comparisons between different plastics. However, applying these characteristics to an evaluation of molded plastic parts is only possible to a limited extent, and can only give the designer a rough guide when it comes to selecting a plastic material. This catalog uses the following assessment criteria: the **RTI value** according to UL746B/ANSI 746 B (elec. based on electric strength) and the **Ti value** according to IEC 60216-1 (based on a 50% reduction in tensile strength after 20,000 hours).

IEC 60947-7-1/EN 60947-7-1 specifies a permissible temperature increase of 45 K for terminal blocks under nominal load. Phoenix Contact terminal blocks fulfill this requirement.

The properties of plastics are not only affected by the influence of heat as described above; they also undergo changes as a result of cold influences. When subjected to cold as well as low levels of humidity, plastics become increasingly brittle with the result that they are no longer capable of withstanding the same mechanical loads. As the table on the right shows, the plastics concerned can be used down to a temperature of -40°C, but only without a mechanical load. As far as the products presented in the catalog are concerned, it is the ambient temperature specified in each case that is to be regarded as definitive for operation. Regardless of the plastics used,

this may be subject to further restrictions (e.g., limited to -20°C) as a result of the components used or other restrictive parameters.

At very low temperatures, this means that any form of mechanical load on the plastic components must be avoided (e.g., mounting of products on/removal of products from the DIN rail, actuation of terminal points, locking/ejection of relays from bases, prizing out of jumpers, bending of cables and lines, etc.), as there is always an associated risk of damage. Unless otherwise indicated, it is recommended that you carry out the specified mounting/operational tasks in a temperature range from -10°C to +40°C.

Inflammability characteristics of plastics (UL 94)

The inflammability tests for plastics have been defined by the Underwriters Laboratory (USA) in regulation UL 94. This applies to all areas of application, particularly in electrical engineering. A horizontal or vertical test is carried out at the test laboratory to determine the inflammability of the plastic material with a naked flame. In order of increasing flame-retardant behavior, the evaluation classes are HB, V2, V1, V0, and 5V. Test results are recorded on "yellow cards" and are published annually in the **Recognized Component Directory**.

Thermoplastics: non-reinforced polyamide, PA

We use the modern, semi-crystalline polyamide insulation material, which has now become an essential component in electrical engineering and electronics. It has long occupied a leading position and is authorized for use by the relevant approval authorities such as the CSA, NEMKO, KEMA, PTB, SEV, UL, VDE, etc.

Polyamide has excellent electrical, mechanical, chemical, and other properties even at high operating temperatures. Brief peak temperatures of up to approximately 200°C are permitted as a result of heat aging stabilization. Depending on the type (PA 4.6, 6.6, 6.10, etc.), its melting point is in the region of 215°C to 295°C.

Polyamide absorbs moisture from its surroundings, on average 2.8%. This is not the embedded water of crystallization, however, but rather chemically bound H₂O groups in the molecular structure. This makes the plastic flexible and resistant to breakage, even at temperatures as low as -40°C. PA belongs to flammability rating V2 to V0 according to UL 94.

Thermoplastics: polyester, PBT

We use the semi-crystalline thermoplastic polyester in non-reinforced and fiberglass-reinforced variants for special applications which require increased dimensional and form stability.

Apart from the high operating temperature, the material is characterized by excellent mechanical strength and hardness. Polyester does not absorb moisture from its surroundings. Therefore, PBT is particularly suitable for strips, for example, that are soldered onto PCBs and are subsequently required to pass a burn-in test where they are subjected to the influence of heat. PBT belongs to flammability rating V2 to V0 according to UL 94.

Thermoplastics: polycarbonate, PC

Polycarbonate combines many advantages such as rigidity, impact strength, transparency, dimensional stability, good insulation properties, and resistance to heat.

The amorphous material only absorbs moisture to a very limited degree, and is used for items such as large, rigid electronic component housings.

In its transparent form, polycarbonate is particularly suitable for use as a material for cover profiles or marking materials.

PC has good resistance properties against mineral acids, saturated aliphatic hydrocarbons, gasoline, greases, and oils.

This material is not very resistant to solvents, benzene, alkalis, acetone, and ammonia. Strain cracks may result from contact with certain chemicals.

PC belongs to flammability rating V2 to V0 according to UL 94.

Thermoplastics: polycarbonate fiber-reinforced, PC-F

Compared to non-reinforced materials, fiber-reinforced polycarbonates feature greater rigidity, impact strength, and operating temperature. In other respects, their properties are largely identical to those of non-reinforced polycarbonate.

Thermoplastics: ABS

We use the thermoplastic molding compound ABS for products which must have good impact and notched impact properties in addition to high mechanical stability and rigidity. The products are resistant to chemicals and stress cracking due to their special surface quality and hardness.

The characteristic thermal properties provide good dimensional stability at both low and high temperatures. Products made from ABS can be coated with metallic

surfaces, e.g., nickel.

The flammability rating of the molding compound used is HB to V0 according to UL 94.

Properties	Unit/level	Polyamide PA	Polyester PBT	Polycarbonate PC	Polycarbonate PC-F	ABS
Operating temperature RTI */**	°C	≤ 105	≤ 105	≤ 125	≤ 120	≤ 80
Minimum temperature (without mechanical load)	°C	-40	-40	-40	-40	-40
Electric strength IEC 60243-1/DIN VDE 0303-21	kV/cm	600	400	> 300		850
Resistance to creepage IEC 60112/DIN VDE 0303-1	CTI...M	550	225	175		200
	CTI...	600	225	175	175	600
Tropical and termite resistance		Good	Good	Good		
Specific contact resistance IEC 60093/VDE 0303 Part 30; IEC 60167/VDE 0303 Part 31	Ω cm	10 ¹²	10 ¹⁶	> 10 ¹⁶	> 10 ¹⁴	10 ¹⁴
Surface resistance IEC 60093/VDE 0303 Part 30; IEC 60167/VDE 0303 Part 31	Ω	10 ¹⁰	10 ¹³	> 10 ¹⁴		10 ¹³
Flammability rating according to UL 94		V2-V0	V0	V2-V0	V0	HB-V0

* According to UL 746 B/ANSI 746 B (elec.)

** Minimum value

Dimensions

Dimensions: **Width/Height/Depth**



The dimensions “**Width/Height/Depth**” are defined as follows for all

DIN-rail-mountable products:

- **Width**: measurement taken along the DIN rail
- **Height**: measurement taken across the DIN rail
- **Depth**: measurement taken starting from the mounting plate and including the DIN rail NS 35/7.5 (EN 60715)

The width, height, and depth never change, even if the products shown in this catalog happen to be photographed from two different perspectives (horizontal or vertical).

To make things easier for you, one of the two symbols shown above has been included next to each product photo:

EMC: Class A product:

In accordance with statutory regulations, our products are indicated with this footnote if they are intended for use in industrial environments. This means that the permitted limit values for residential applications may be exceeded in the event of conducted and emitted disturbance variables. In such cases, the operator may have to take additional safety measures in order to ensure electromagnetic compatibility in residential applications.

Note:

Subject to changes that serve the purpose of technical progress.

Connection cross section

The rated cross section of terminal blocks must be specified by the manufacturer according to IEC 60947-7-1. The rated cross section is the maximum conductor cross section that can be connected in single, multi or fine-strand versions subject to specific thermal, mechanical, and electrical requirements.

The manufacturer must also specify the **rated connection capacity**, i.e., the area of connectable conductors as well as the number of conductors which can be connected simultaneously and the necessary preparation of the conductor ends. The conductors can be **solid (single or multi-**

strand) or flexible (**fine-strand**).

These values can be found in the product-specific technical data.

The rated connection capacity of Phoenix Contact terminal blocks usually exceeds standard requirements, which specify that it must only be possible to connect one conductor with one of the two next smallest cross sections, excluding the rated cross section (standardized for the cross section range from 0.2 to 35 mm²).

In addition, conductors with a rated cross section can usually be wired with ferrules with plastic sleeve.

Phoenix Contact terminal blocks are

designed to allow copper conductors to be connected to them untreated. "Special treatment" or the use of ferrules – both permitted according to IEC 60947-7-1 – are not required. If ferrules are nevertheless used to protect stranded conductors against splicing, the connection capacity of the stranded conductor is generally reduced by one level.

Structure and dimensions of connecting cables

Cross section [mm ²]	Single-stranded		Multi-stranded		Fine-stranded		Gauge no. AWG	American Wire Gauge [AWG]					
	Diameter max. dimension	Number of wires	Diameter max. dimension	Number of wires (minimum number)	Diameter max. dimension	Number of wires (guide value)		Solid wires			Stranded wires		
								[Ø mm]	[circ. mils]	[mm ²]	[Ø mm]	[circ. mils]	[mm ²]
0.2	0.5	1	–	–	–	–	24	0.51	404	0.21	–	–	–
0.5	0.9	1	1.1	7	1.1	16	20	0.81	1022	0.52	0.97	1111	0.56
0.75	1.0	1	1.2	7	1.3	24	18	1.02	1620	0.82	1.16	1600	0.82
1	1.2	1	1.4	7	1.5	32	(17)	1.15	2050	1.04	–	–	–
–	–	–	–	–	–	–	16	1.29	2580	1.31	1.50	2580	1.32
1.5	1.5	1	1.7	7	1.8	30	(15)	1.45	3260	1.65	–	–	–
–	–	–	–	–	–	–	14	1.63	4110	2.08	1.85	4100	2.09
2.5	1.9	1	2.2	7	2.3	50	(13)	1.83	5180	2.63	–	–	–
–	–	–	–	–	–	–	12	2.05	6530	3.31	2.41	6500	3.32
4	2.4	1	2.7	7	2.9	56	(11)	2.30	8230	4.17	–	–	–
–	–	–	–	–	–	–	10	2.59	10380	5.26	2.95	10530	5.37
6	2.9	1	3.3	7	3.9	84	(9)	2.91	13100	6.63	–	–	–
–	–	–	–	–	–	–	8	3.26	16510	8.37	3.73	16625	8.48

Tightening torque of terminal block screws

IEC 60947-1/EN 60947-1, modified, Table 4 specifies tightening torques for screw connections based on the screw size for electrical and mechanical type tests.

Extract from IEC 60947-1/EN 60947-1, Table 4

The torque according to IEC and the recommended torque for Phoenix Contact terminal blocks are specified

Thread	Head screw with slot	
	Torque	Recommended tightening torque
	[Nm]	[Nm]
M2.5 (M2.6)	0.4	0.4 - 0.5
M3	0.5	0.5 - 0.6
M3.5	0.8	0.8 - 1.0
M4	1.2	1.2 - 1.5

















































Current carrying capacity

Standard IEC 60947-7-1/EN 60947-7-1/DIN VDE 0611-1 specifies the test currents for the individual conductor cross sections listed in the adjacent table. The corresponding currents are listed with the connection data for the individual terminal blocks. The type tests of terminal blocks are based on this data.

Test currents according to IEC 60947-7-1/EN 60947-7-1, Table 5

Rated cross section	[mm ²]	0.2	0.5	0.75	1.0	1.5	2.5	4	6	10	16
Test current	[A]	4	6	9	13.5	17.5	24	32	41	57	76

Certification bodies and safety marks

Certification bodies and approvals	Country code	Explosion protection	Country code	Marine classification societies	Country code
 IECCE CB Scheme (in combination with certifying body)	International	 International Electrotechnical Commission	International	 DNV GL - MARITIME	DE
 CENELEC Certification Agreement (CCA inspection report) (in combination with certifying body)	EU	 ATEX Directive	EU	 Bureau Veritas	FR
 Canadian Standards Association (CSA)	CA	 DEKRA Certification B.V.	NL	 Germanischer Lloyd AG	DE
 Canadian Standards Association (CSA) - CSA approval for the USA -	US	 Physikalisch-Technische Bundesanstalt	DE	 Lloyd's Register of Shipping	GB
 Canadian Standards Association (CSA) Combined logo - CSA approval for Canada and the USA -	CA US	 KIWA Nederland B.V.	NL	 Nippon Kaiji Kyokai	JP
 Underwriters Laboratories Inc. (UL)	US	 VTT Expert Services Oy	FI	 Det Norske Veritas	NO
 Underwriters Laboratories Inc. (UL) - UL approval for Canada -	CA	 IBExU Institut für Sicherheitstechnik GmbH	DE	 Polski Rejestr Statków	PL
 Underwriters Laboratories Inc. (UL) Combined logo - UL approval for the USA and Canada -	US CA	 TÜV Rheinland do Brasil	BR	 Russian Maritime Register of Shipping	RU
 INSIEME PER LA QUALITA' E LA SICUREZZA	IT	 Technischer Überwachungsverein Nord	DE	 Korean Register of Shipping	KR
 Eurasian Conformity	BY KZ RU	 DEKRA EXAM GmbH	DE	 American Bureau of Shipping	US
 DEKRA Certification B.V.	NL	 Canadian Standards Association (CSA)	CA		
 Österreichischer Verband für Elektrotechnik	AT	 Canadian Standards Association (CSA) - CSA approval for the USA -	US		
 electrosuisse SEV Verband für Elektro-, Energie- und Informationstechnik	CH	 Canadian Standards Association (CSA) Combined logo - CSA approval for Canada and the USA -	CA US		
 Verband Deutscher Elektrotechniker e.V. (VDE) - Approval of drawings - Reports with production monitoring	DE	 Underwriters Laboratories Inc. (UL)	US		
 Berufsgenossenschaft (BG) GS Tested safety	DE	 Underwriters Laboratories Inc. (UL) - UL approval for Canada -	CA		
 Intertek ETL Listed - Approval for the USA -	US	 Underwriters Laboratories Inc. (UL) Combined logo - UL approval for the USA and Canada -	US CA		
 Intertek ETL Listed - Approval for Canada -	CA	 FM Approvals	US		
 Intertek ETL Listed - Approval for the USA and Canada -	US CA	 Eurasian Conformity for Ex-products	BY KZ RU		
 TÜV Rheinland Industrie Service GmbH	DE				
 China Compulsory Certification	CN				
 Korea Communications Commission	KR				

Index

Alphabetical

Type	Order No.	Page	Type	Order No.	Page	Type	Order No.	Page	Type	Order No.	Page
B											
BRIDGE COVER	2906240	34	CABLE-D-15SUB-F/OE-0,25-S/...	2900905	596	CABLE-D25SUB/B/2X14/500/TU812	2304678	471	CABLE-FCN40/1X50/1,0M/M340	2321648	495
BRIDGE-2	2900746	34	CABLE-D-15SUB-M/OE-0,25-S/...	2900910	596	CABLE-D25SUB/B/2X14/TU812/...	2304681	471	CABLE-FCN40/1X50/1,0M/S7-IN	2321101	505
BRIDGE-2-3M	2901543	35	CABLE-D-15SUB/F/OE/0,25/S/0,5M	2926085	596	CABLE-D25SUB/B/B/100/KONFEK/S	2305473	593	CABLE-FCN40/1X50/1,0M/S7-OUT	2321020	505
BRIDGE-3	2900747	34	CABLE-D-15SUB/F/OE/0,25/S/1,0M	2926098	596	CABLE-D25SUB/B/B/200/KONFEK/S	2305486	593	CABLE-FCN40/1X50/2,0M/M/MEL	2903470	489
BRIDGE-3-3M	2901656	35	CABLE-D-15SUB/F/OE/0,25/S/1,5M	2926108	596	CABLE-D25SUB/B/B/300/KONFEK/S	2305499	593	CABLE-FCN40/1X50/2,0M/M340	2321651	495
BRIDGE-4	2900748	34	CABLE-D-15SUB/F/OE/0,25/S/2,0M	2926111	596	CABLE-D25SUB/B/S/50/KONFEK/S	2302120	592	CABLE-FCN40/1X50/2,0M/S7-IN	2321114	505
BRIDGE-4-3M	2901659	35	CABLE-D-15SUB/F/OE/0,25/S/4,0M	2926137	596	CABLE-D25SUB/B/S/100/KONFEK/S	2302146	592	CABLE-FCN40/1X50/2,0M/S7-OUT	2321033	505
BRIDGE-5	2900749	34	CABLE-D-15SUB/F/OE/0,25/S/6,0M	2926140	596	CABLE-D25SUB/B/S/200/KONFEK/S	2302159	592	CABLE-FCN40/1X50/2,0M/M/MEL	2903471	489
BRIDGE-5-3M	2901656	35	CABLE-D-15SUB/M/OE/0,25/S/0,5M	2926438	596	CABLE-D25SUB/B/S/300/KONFEK/S	2302162	592	CABLE-FCN40/1X50/3,0M/M/MEL	2903479	489
BRIDGE-6	2900748	34	CABLE-D-15SUB/M/OE/0,25/S/1,0M	2926441	596	CABLE-D25SUB/B/S/400/KONFEK/S	2302175	592	CABLE-FCN40/1X50/3,0M/M340	2321664	495
BRIDGE-6-3M	2901697	35	CABLE-D-15SUB/M/OE/0,25/S/1,5M	2926454	596	CABLE-D25SUB/B/S/600/KONFEK/S	2302188	592	CABLE-FCN40/1X50/3,0M/S7-IN	2321127	505
BRIDGE-7	2900751	34	CABLE-D-15SUB/M/OE/0,25/S/2,0M	2926467	596	CABLE-D25SUB/S/S/100/KONFEK/S	2305635	593	CABLE-FCN40/1X50/3,0M/S7-OUT	2321046	505
BRIDGE-7-3M	2901698	35	CABLE-D-15SUB/M/OE/0,25/S/3,0M	2926470	596	CABLE-D25SUB/S/S/200/KONFEK/S	2305648	593	CABLE-FCN40/1X50/4,0M/M/MEL	2903472	489
BRIDGE-8	2900752	34	CABLE-D-15SUB/M/OE/0,25/S/4,0M	2926483	596	CABLE-D25SUB/S/S/300/KONFEK/S	2305651	593	CABLE-FCN40/1X50/4,0M/M/MEL	2903480	489
BRIDGE-8-3M	2901700	35	CABLE-D-15SUB/M/OE/0,25/S/6,0M	2926496	596	CABLE-D37-M2,5-4X14-X81-IL/...	2302706	488	CABLE-FCN40/1X50/4,0M/M340	2321677	495
BRIDGE-9	2900753	34	CABLE-D-25SUB-F/OE-0,25-S/...	2900906	596	CABLE-D37-M2,5-4X14-X81-P-O/...	2302696	488	CABLE-FCN40/1X50/4,0M/S7-IN	2321130	505
BRIDGE-9-3M	2901701	35	CABLE-D-25SUB-M/OE-0,25-S/...	2900911	596	CABLE-D37-M2,5-4X14/200/X81-I	2302515	488	CABLE-FCN40/1X50/4,0M/S7-OUT	2321059	505
BRIDGE-10	2900754	34	CABLE-D-25SUB/F/OE/0,25/S/0,5M	2926153	596	CABLE-D37-M2,5-4X14/50Y81-P-O	2302476	488	CABLE-FCN40/1X50/6,0M/M/MEL	2903473	489
BRIDGE-10-3M	2901702	35	CABLE-D-25SUB/F/OE/0,25/S/1,0M	2926166	596	CABLE-D37-M2,5-4X14/100/X81-I	2302528	488	CABLE-FCN40/1X50/6,0M/M/MEL	2903481	489
BRIDGE-PT 2	2904490	35	CABLE-D-25SUB/F/OE/0,25/S/1,5M	2926179	596	CABLE-D37-M2,5-4X14/100Y81-P-O	2302489	488	CABLE-FCN40/1X50/6,0M/M340	2321680	495
BRIDGE-PT 3	2904491	35	CABLE-D-25SUB/F/OE/0,25/S/2,0M	2926182	596	CABLE-D37-M2,5-4X14/200/X81-I	2302531	488	CABLE-FCN40/1X50/6,0M/S7-IN	2321143	505
BRIDGE-PT 4	2904492	35	CABLE-D-25SUB/F/OE/0,25/S/3,0M	2926195	596	CABLE-D37-M2,5-4X14/200Y81-P-O	2302492	488	CABLE-FCN40/1X50/6,0M/S7-OUT	2321062	505
BRIDGE-PT 5	2904493	35	CABLE-D-25SUB/M/OE/0,25/S/0,5M	2926205	596	CABLE-D37-M2,5-4X14/300/X81-I	2302544	488	CABLE-FCN40/1X50/6,0M/M/MEL	2903474	489
BRIDGE-PT 6	2904494	35	CABLE-D-25SUB/M/OE/0,25/S/1,0M	2926218	596	CABLE-D37-M2,5-4X14/300Y81-P-O	2302502	488	CABLE-FCN40/1X50/8,0M/M/MEL	2903482	489
BRIDGE-PT 7	2904495	35	CABLE-D-25SUB/M/OE/0,25/S/1,5M	2926256	596	CABLE-D37-M2,5-4X14/100/KONFEK/S	2305509	593	CABLE-FCN40/1X50/8,0M/M340	2321693	495
BRIDGE-PT 8	2904496	35	CABLE-D-25SUB/M/OE/0,25/S/2,0M	2926519	596	CABLE-D37SUB/B/B/200/KONFEK/S	2305512	593	CABLE-FCN40/1X50/8,0M/S7-IN	2321156	505
BRIDGE-PT 9	2904497	35	CABLE-D-25SUB/M/OE/0,25/S/3,0M	2926535	596	CABLE-D37SUB/B/B/300/KONFEK/S	2305525	593	CABLE-FCN40/1X50/8,0M/S7-OUT	2321075	505
BRIDGE-PT 10	2904498	35	CABLE-D-25SUB/M/OE/0,25/S/4,0M	2926548	596	CABLE-D37SUB/B/B/400/KONFEK/S	2900759	593	CABLE-FCN40/1X50/10,0M/M/MEL	2903475	489
			CABLE-D-25SUB/M/OE/0,25/S/6,0M	2926548	596	CABLE-D37SUB/B/B/600/KONFEK/S	2900760	593	CABLE-FCN40/1X50/10,0M/M/MEL	2903483	489
			CABLE-D-37SUB-F/OE-0,25-S/...	2900907	597	CABLE-D37SUB/B/B/800/KONFEK/S	2900761	593	CABLE-FCN40/1X50/10,0M/M340	2321703	495
			CABLE-D-37SUB-M/OE-0,25-S/...	2900912	597	CABLE-D37SUB/B/B/1000/KONFEK/S	2900762	593	CABLE-FCN40/1X50/10,0M/S7-IN	2321169	505
			CABLE-D-37SUB/F/OE/0,25/S/0,5M	2926221	597	CABLE-D37SUB/B/B/1500/KONFEK/S	2900763	593	CABLE-FCN40/1X50/10,0M/S7-OUT	2321088	505
			CABLE-D-37SUB/F/OE/0,25/S/1,0M	2926234	597	CABLE-D37SUB/B/B/2000/KONFEK/S	2900764	593	CABLE-FCN40/1X50/15,0M/M340	2903748	495
C						CABLE-D37SUB/B/B/HF/S/1,0M	2908516	593	CABLE-FCN40/4X14/0,5M/M/MEL	2903502	489
CAB-USB A/MICRO USB B/2,0M	2701626	432	CABLE-D-37SUB/B/F/OE/0,25/S/1,0M	2926234	597	CABLE-D37SUB/B/B/HF/S/2,0M	2908517	593	CABLE-FCN40/4X14/0,5M/M340	2321716	495
CABLE D-SUB-B-B-S/...	2302421	595	CABLE-D-37SUB/F/OE/0,25/S/1,5M	2926247	597	CABLE-D37SUB/B/B/HF/S/3,0M	2908518	593	CABLE-FCN40/4X14/0,5M/S7-IN	2321253	505
CABLE D-SUB-S-S-S/...	2302434	595	CABLE-D-37SUB/F/OE/0,25/S/2,0M	2926250	597	CABLE-D37SUB/B/B/HF/S/4,0M	2908519	593	CABLE-FCN40/4X14/0,5M/S7-OUT	2321172	505
CABLE D-SUB-S-S-S/...	2302340	595	CABLE-D-37SUB/F/OE/0,25/S/3,0M	2926263	597	CABLE-D37SUB/B/B/HF/S/6,0M	2908520	593	CABLE-FCN40/4X14/1,0M/M/MEL	2903503	489
			CABLE-D-37SUB/F/OE/0,25/S/4,0M	2926276	597	CABLE-D37SUB/B/B/HF/S/8,0M	2908521	593	CABLE-FCN40/4X14/1,0M/M340	2321729	495
CABLE-40/2FLK16/2,0M/YUC	2321334	517	CABLE-D-37SUB/F/OE/0,25/S/6,0M	2926289	597	CABLE-D37SUB/B/B/HF/S/10,0M	2908522	593	CABLE-FCN40/4X14/1,0M/S7-IN	2321266	505
CABLE-40/2FLK16/4,0M/YUC	2321347	517	CABLE-D-37SUB/M/OE/0,25/S/0,5M	2926577	597	CABLE-D37SUB/B/B/HF/S/15,0M	2908523	593	CABLE-FCN40/4X14/1,0M/S7-OUT	2321185	505
CABLE-40/2FLK16/10,0M/YUC	2321350	517	CABLE-D-37SUB/M/OE/0,25/S/1,0M	2926580	597	CABLE-D37SUB/B/B/HF/S/20,0M	2908525	593	CABLE-FCN40/4X14/2,0M/M/MEL	2903504	489
CABLE-40/2FLK16/15,0M/YUC	2321376	517	CABLE-D-37SUB/M/OE/0,25/S/1,5M	2926593	597	CABLE-D37SUB/B/S/50/KONFEK/S	2302191	592	CABLE-FCN40/4X14/2,0M/M340	2321732	495
CABLE-40/2FLK16/20,0M/YUC	2321363	517	CABLE-D-37SUB/M/OE/0,25/S/2,0M	2926603	597	CABLE-D37SUB/B/S/100/KONFEK/S	2302201	592	CABLE-FCN40/4X14/2,0M/S7-IN	2321279	505
CABLE-50/4FLK14/2,0M/YUC	2314655	517	CABLE-D-37SUB/M/OE/0,25/S/3,0M	2926616	597	CABLE-D37SUB/B/S/200/KONFEK/S	2302227	592	CABLE-FCN40/4X14/2,0M/S7-OUT	2321198	505
CABLE-50/4FLK14/4,0M/YUC	2314671	517	CABLE-D-37SUB/M/OE/0,25/S/4,0M	2926629	597	CABLE-D37SUB/B/S/300/KONFEK/S	2302230	592	CABLE-FCN40/4X14/3,0M/M/MEL	2903505	489
CABLE-50/4FLK14/6,0M/YUC	2318978	517	CABLE-D-37SUB/M/OE/0,25/S/6,0M	2926632	597	CABLE-D37SUB/B/S/400/KONFEK/S	2302243	592	CABLE-FCN40/4X14/3,0M/M340	2321745	495
CABLE-50/4FLK14/10,0M/YUC	2314684	517	CABLE-D-50SUB-F/OE-0,25-S/...	2900908	597	CABLE-D37SUB/B/S/600/KONFEK/S	2302256	592	CABLE-FCN40/4X14/3,0M/S7-IN	2321282	505
CABLE-50/4FLK14/15,0M/YUC	2322773	517	CABLE-D-50SUB-M/OE-0,25-S/...	2900913	597	CABLE-D37SUB/S/S/100/KONFEK/S	2305664	593	CABLE-FCN40/4X14/3,0M/S7-OUT	2321208	505
CABLE-50/4FLK14/20,0M/YUC	2314778	517	CABLE-D-50SUB/F/OE/0,25/S/0,5M	2926292	597	CABLE-D37SUB/S/S/200/KONFEK/S	2305677	593	CABLE-FCN40/4X14/3,0M/M/MEL	2903506	489
CABLE-D 9SUB/B/B/100/KONFEK/S	2305415	593	CABLE-D-50SUB/F/OE/0,25/S/1,0M	2926302	597	CABLE-D37SUB/S/S/300/KONFEK/S	2305680	593	CABLE-FCN40/4X14/4,0M/M340	2321758	495
CABLE-D 9SUB/B/B/200/KONFEK/S	2305428	593	CABLE-D-50SUB/F/OE/0,25/S/1,5M	2926315	597	CABLE-D50SUB/B/B/100/KONFEK/S	2305541	593	CABLE-FCN40/4X14/4,0M/S7-IN	2321295	505
CABLE-D 9SUB/B/B/300/KONFEK/S	2305431	593	CABLE-D-50SUB/F/OE/0,25/S/2,0M	2926328	597	CABLE-D50SUB/B/B/200/KONFEK/S	2305554	593	CABLE-FCN40/4X14/4,0M/S7-OUT	2321211	505
CABLE-D 9SUB/B/B/S/100/KONFEK/S	2299987	592	CABLE-D-50SUB/F/OE/0,25/S/3,0M	2926331	597	CABLE-D50SUB/B/B/300/KONFEK/S	2305567	593	CABLE-FCN40/4X14/6,0M/M/MEL	2903507	489
CABLE-D 9SUB/B/B/S/200/KONFEK/S	2299990	592	CABLE-D-50SUB/F/OE/0,25/S/4,0M	2926344	597	CABLE-D50SUB/B/S/50/KONFEK/S	2302269	592	CABLE-FCN40/4X14/6,0M/M340	2321761	495
CABLE-D 9SUB/B/B/S/300/KONFEK/S	2300009	592	CABLE-D-50SUB/F/OE/0,25/S/6,0M	2926357	597	CABLE-D50SUB/B/S/100/KONFEK/S	2302272	592	CABLE-FCN40/4X14/6,0M/S7-IN	2321305	505
CABLE-D 9SUB/B/S/150/KONFEK/S	2302010	592	CABLE-D-50SUB/M/OE/0,25/S/0,5M	2926645	597	CABLE-D50SUB/B/S/150/KONFEK/S	2302285	592	CABLE-FCN40/4X14/6,0M/S7-OUT	2321224	505
CABLE-D 9SUB/B/S/200/KONFEK/S	2302013	592	CABLE-D-50SUB/M/OE/0,25/S/1,0M	2926658	597	CABLE-D50SUB/B/S/200/KONFEK/S	2302298	592	CABLE-FCN40/4X14/6,0M/M/MEL	2903508	489
CABLE-D 9SUB/B/S/300/KONFEK/S	2302023	592	CABLE-D-50SUB/M/OE/0,25/S/1,5M	2926661	597	CABLE-D50SUB/B/S/300/KONFEK/S	2302306	592	CABLE-FCN40/4X14/8,0M/M340	2321774	495
CABLE-D 9SUB/B/S/400/KONFEK/S	2302036	592	CABLE-D-50SUB/M/OE/0,25/S/2,0M	2926674	597	CABLE-D50SUB/B/S/400/KONFEK/S	2302311	592	CABLE-FCN40/4X14/8,0M/S7-IN	2321318	505
CABLE-D 9SUB/B/S/600/KONFEK/S	2302049	592	CABLE-D-50SUB/M/OE/0,25/S/3,0M	2926687	597	CABLE-D50SUB/B/S/600/KONFEK/S	2302324	592	CABLE-FCN40/4X14/8,0M/S7-OUT	2321237	505
CABLE-D 9SUB/S/S/100/KONFEK/S	2305570	593	CABLE-D-50SUB/M/OE/0,25/S/4,0M	2926690	597	CABLE-D50SUB/S/S/100/KONFEK/S	2305693	593	CABLE-FCN40/4X14/10,0M/M/MEL	2903509	489
CABLE-D 9SUB/S/S/200/KONFEK/S	2305583	593	CABLE-D-50SUB/M/OE/0,25/S/6,0M	2926700	597	CABLE-D50SUB/S/S/200/KONFEK/S	2305703	593	CABLE-FCN40/4X14/10,0M/M340	2321787	495
CABLE-D 9SUB/S/S/300/KONFEK/S	2305596	593	CABLE-D-15SUB-B/B/100/KONFEK/S	2305444	593	CABLE-D50SUB/S/S/300/KONFEK/S	2305716	593	CABLE-FCN40/4X14/10,0M/S7-IN	2321321	505
CABLE-D-9SUB-F/OE-0,25-S/...	2900903	596	CABLE-D-15SUB-B/B/200/KONFEK/S	2305457	593	CABLE-FCN24-2X14-OMR-IN/...	2302845	490	CABLE-FCN40/4X14/10,0M/S7-OUT	2321240	505
CABLE-D-9SUB-M/OE-0,25-S/...	2900909	596	CABLE-D-15SUB-B/B/300/KONFEK/S	2305460	593	CABLE-FCN24-2X14-OMR-OUT/...	2302858	490	CABLE-FCN40/4X14/100/OMR-IN	2304209	490
CABLE-D-9SUB/F/OE/0,25/S/0,5M	2926014	596	CABLE-D-1								

Type	Order No.	Page	Type	Order No.	Page	Type	Order No.	Page
CABLE-FLK10/OE/0,14/ 8,0M	2904081	584	DEK-OE- 60DC/ 48DC/100	2941536	440	ELR 3- 24DC/500AC- 9	2297219	43
CABLE-FLK10/OE/0,14/10,0M	2904082	584	DEK-OE-120AC/ 48DC/100	2941659	440	ELR 3- 24DC/500AC-16	2297235	43
CABLE-FLK14/OE/0,14/ 50	2305761	584	DEK-OE-230AC/ 48DC/100	2942010	440	ELR 3-230AC/500AC- 2	2297206	42
CABLE-FLK14/OE/0,14/ 100	2305253	584	DEK-OE-230AC/ 48DC/100/SO 46	2964678	445	ELR 3-230AC/500AC- 9	2297222	43
CABLE-FLK14/OE/0,14/ 150	2305266	584	DEK-OV- 5DC/ 24DC/ 3	2941361	441	ELR 3-230AC/500AC-16	2297248	43
CABLE-FLK14/OE/0,14/ 200	2305279	584	DEK-OV- 5DC/ 24DC/ 10	2961752	441	ELR 5011 IP PN	2700745	50
CABLE-FLK14/OE/0,14/ 250	2305282	584	DEK-OV- 5DC/240AC/800	2964623	441	ELR 5011-2 IP PN	2701007	50
CABLE-FLK14/OE/0,14/ 300	2305295	584	DEK-OV- 12DC/ 24DC/ 3	2941387	441	ELR 5030 IP PN	2701006	51
CABLE-FLK14/OE/0,14/ 400	2305774	584	DEK-OV- 12DC/ 24DC/ 10	2961749	441	ELR 5030-2 IP PN	2701008	51
CABLE-FLK14/OE/0,14/ 600	2305787	584	DEK-OV- 12DC/240AC/800	2964636	441	ELR H3-I-PT- 24DC/500AC-0,6	2903920	31
CABLE-FLK14/OE/0,14/ 800	2305790	584	DEK-OV-24DC/ 24DC/ 3	2941374	441	ELR H3-I-PT- 24DC/500AC-2	2903922	31
CABLE-FLK14/OE/0,14/...	2305732	584	DEK-OV-24DC/ 24DC/ 3/AKT	2964296	441	ELR H3-I-PT- 24DC/500AC-9	2903924	31
CABLE-FLK14/OE/0,14/1000	2305800	584	DEK-OV-24DC/ 24DC/ 10	2964322	441	ELR H3-I-PT-SWD/500AC-06	2905076	29
CABLE-FLK16/OE/0,14/ 0,5M	2318127	584	DEK-OV- 24DC/240AC/800	2964649	441	ELR H3-I-PT-SWD/500AC-3	2905078	29
CABLE-FLK16/OE/0,14/ 1,0M	2318130	584	DEK-REL- 5//1	2941183	438	ELR H3-I-PT-SWD/500AC-9	2905079	29
CABLE-FLK16/OE/0,14/ 1,5M	2318143	584	DEK-REL- 5/O/1	2941170	439	ELR H3-I-PT/500AC-06-IFS	2905148	27
CABLE-FLK16/OE/0,14/ 2,0M	2318156	584	DEK-REL- 24/1/AKT	2964063	439	ELR H3-I-PT/500AC-3-IFS	2905149	27
CABLE-FLK16/OE/0,14/ 2,5M	2318169	584	DEK-REL- 24/1/S	2964131	443	ELR H3-I-PT/500AC-9-IFS	2905150	27
CABLE-FLK16/OE/0,14/ 3,0M	2318172	584	DEK-REL- 24/1/SEN	2964050	439	ELR H3-I-SC- 24DC/500AC-0,6	2900542	31
CABLE-FLK16/OE/0,14/ 4,0M	2318185	584	DEK-REL- 24/1/I	2940171	438	ELR H3-I-SC- 24DC/500AC-2	2900543	31
CABLE-FLK16/OE/0,14/ 6,0M	2318198	584	DEK-REL- 24/O/1	2941154	439	ELR H3-I-SC- 24DC/500AC-9	2900545	31
CABLE-FLK16/OE/0,14/ 8,0M	2318208	584	DEK-REL-G24/21	2964500	437	ELR H3-I-SC-230AC/500AC-2	2900544	31
CABLE-FLK16/OE/0,14/...	2318224	584	DEK-TR/INV	2964319	453	ELR H3-I-SC-230AC/500AC-9	2900546	31
CABLE-FLK16/OE/0,14/10,0M	2318211	584	DFLK-D 9 SUB/B	2287135	575	ELR H3-I-SC/500AC-06-IFS	2905162	27
CABLE-FLK20/OE/0,14/ 50	2305826	585	DFLK-D 9 SUB/S	2283870	575	ELR H3-I-SC/500AC-3-IFS	2905163	27
CABLE-FLK20/OE/0,14/ 100	2305305	585	DFLK-D15 SUB/B	2280307	575	ELR H3-I-SC/500AC-9-IFS	2905164	27
CABLE-FLK20/OE/0,14/ 150	2305318	585	DFLK-D15 SUB/S	2280297	575	ELR H3-IES-PT- 24DC/500AC-0,6	2903914	30
CABLE-FLK20/OE/0,14/ 200	2305321	585	DFLK-D25 SUB/B	2280323	575	ELR H3-IES-PT- 24DC/500AC-2	2903916	30
CABLE-FLK20/OE/0,14/ 250	2305334	585	DFLK-D25 SUB/S	2280310	575	ELR H3-IES-PT- 24DC/500AC-9	2903918	30
CABLE-FLK20/OE/0,14/ 300	2305347	585	DFLK-D37 SUB/B	2280349	575	ELR H3-IES-PT-SWD/500AC-06	2903936	28
CABLE-FLK20/OE/0,14/ 400	2305839	585	DFLK-D37 SUB/S	2280336	575	ELR H3-IES-PT-SWD/500AC-3	2903937	28
CABLE-FLK20/OE/0,14/ 600	2305842	585	DFLK-D50 SUB/B	2287669	575	ELR H3-IES-PT-SWD/500AC-9	2903938	28
CABLE-FLK20/OE/0,14/ 800	2305855	585	DFLK-D50 SUB/S	2291286	575	ELR H3-IES-PT/500AC-06-IFS	2905141	26
CABLE-FLK20/OE/0,14/...	2305745	585	DIKD 1,5	2715979	439	ELR H3-IES-PT/500AC-3-IFS	2905142	26
CABLE-FLK20/OE/0,14/1000	2305868	585				ELR H3-IES-PT/500AC-3-IOL	2908671	27
CABLE-FLK50/0,14/HF/ 0,5M	2314134	587				ELR H3-IES-PT/500AC-9-IFS	2905143	26
CABLE-FLK50/0,14/HF/ 1,0M	2314147	587				ELR H3-IES-PT/500AC-9-IOL	2908672	27
CABLE-FLK50/0,14/HF/ 1,5M	2314150	587				ELR H3-IES-SC- 24DC/500AC-0,6	2900566	30
CABLE-FLK50/0,14/HF/ 2,0M	2314163	587				ELR H3-IES-SC- 24DC/500AC-2	2900567	30
CABLE-FLK50/0,14/HF/ 2,5M	2314176	587				ELR H3-IES-SC- 24DC/500AC-9	2900569	30
CABLE-FLK50/0,14/HF/ 3,0M	2314189	587	EB 2- DIK BU	2716648	443	ELR H3-IES-SC-230AC/500AC-2	2900568	30
CABLE-FLK50/0,14/HF/ 4,0M	2314192	587	EB 2- DIK RD	2716693	443	ELR H3-IES-SC-230AC/500AC-9	2900570	30
CABLE-FLK50/0,14/HF/ 5,0M	2314202	587	EB 3- DIK BU	2716651	443	ELR H3-IES-SC/500AC-06-IFS	2905154	26
CABLE-FLK50/0,14/HF/ 6,0M	2314215	587	EB 3- DIK RD	2716745	443	ELR H3-IES-SC/500AC-3-IFS	2905155	26
CABLE-FLK50/0,14/HF/ 7,0M	2314228	587	EB 4- DIK BU	2716664	443	ELR H3-IES-SC/500AC-9-IFS	2905156	26
CABLE-FLK50/0,14/HF/ 8,0M	2314231	587	EB 4- DIK RD	2716758	443	ELR H3-SC- 24DC/500AC-9	2900530	31
CABLE-FLK50/0,14/HF/10,0M	2314244	587	EB 5- DIK BU	2716677	443	ELR H3-SC-230AC/500AC-9	2900531	31
CABLE-FLK50/OE/0,14/ 50	2305871	585	EB 5- DIK RD	2716761	443	ELR H5-I-PT- 24DC/500AC-0,6	2903908	25
CABLE-FLK50/OE/0,14/ 100	2305350	585	EB 10- DIK BU	2716680	443	ELR H5-I-PT- 24DC/500AC-2	2903910	25
CABLE-FLK50/OE/0,14/ 150	2305363	585	EB 10- DIK RD	2716774	443	ELR H5-I-PT- 24DC/500AC-9	2903912	25
CABLE-FLK50/OE/0,14/ 200	2305376	585	EB 80- DIK BU	2715940	437	ELR H5-I-PT-SWD/500AC-06	2905073	23
CABLE-FLK50/OE/0,14/ 250	2305389	585	EB 80- DIK RD	2715953	437	ELR H5-I-PT-SWD/500AC-3	2905074	23
CABLE-FLK50/OE/0,14/ 300	2305392	585	EB 80- DIK WH	2715788	437	ELR H5-I-PT-SWD/500AC-9	2905075	23
CABLE-FLK50/OE/0,14/ 400	2305884	585	EEM-2AO-MA600	2901475	210	ELR H5-I-PT/500AC-06-IFS	2905144	21
CABLE-FLK50/OE/0,14/ 600	2305897	585	EEM-2DIO-MA600	2901371	210	ELR H5-I-PT/500AC-3-IFS	2905146	21
CABLE-FLK50/OE/0,14/ 800	2305907	585	EEM-ETH-MA600	2901373	211	ELR H5-I-PT/500AC-9-IFS	2905147	21
CABLE-FLK50/OE/0,14/...	2305758	585	EEM-ETH-RS485-MA600	2901374	211	ELR H5-I-SC- 24DC/500AC-0,6	2900573	25
CABLE-FLK50/OE/0,14/1000	2305910	585	EEM-IMP-MA400	2904314	212	ELR H5-I-SC- 24DC/500AC-2	2900574	25
CLIPFIX 35	3022218	366	EEM-IMP-MA600	2904313	212	ELR H5-I-SC- 24DC/500AC-9	2900576	25
CM-KBL-RS232/USB	2881078	251	EEM-MA200	2901362	209	ELR H5-I-SC-230AC/500AC-2	2900575	25
COM CAB MINI DIN	2400127	214	EEM-MA250	2901363	209	ELR H5-I-SC-230AC/500AC-9	2900578	25
			EEM-MA400	2901364	209	ELR H5-I-SC/500AC-06-IFS	2905157	21
			EEM-MA600	2901366	208	ELR H5-I-SC/500AC-3-IFS	2905159	21
			EEM-MA600-24DC	2902352	208	ELR H5-I-SC/500AC-9-IFS	2905160	21
			EEM-MEMO-MA600	2901370	210	ELR H5-IES-PT- 24DC/500AC-0,6	2903902	24
			EEM-MKT-DRA	2902078	213	ELR H5-IES-PT- 24DC/500AC-2	2903904	24
			EEM-PB 12-MA600	2901418	211	ELR H5-IES-PT- 24DC/500AC-9	2903906	24
			EEM-RS485-MA400	2901365	211	ELR H5-IES-PT-SWD/500AC-06	2903933	22
D-DEK 1,5 GN	2716949	437	EEM-RS485-MA600	2901367	211	ELR H5-IES-PT-SWD/500AC-3	2903934	22
D-UKK 3/5	2770024	176	EIK1-SVN-24P	2940799	452	ELR H5-IES-PT-SWD/500AC-9	2903935	22
D-UKK 3/5 BU	2770105	176	EL3-M52	2833628	319	ELR H5-IES-PT/500AC-06-IFS	2905138	20
DEK-OE- 5DC/ 5DC/100KHZ-G	2964542	451	ELR 1- 24DC/600AC-20	2297138	48	ELR H5-IES-PT/500AC-3-IFS	2905139	20
DEK-OE- 5DC/ 24DC/100KHZ	2964270	450	ELR 1- 24DC/600AC-30	2297154	49	ELR H5-IES-PT/500AC-3-IOL	2908669	21
DEK-OE- 5DC/ 24DC/100KHZ-G	2964555	451	ELR 1- 24DC/600AC-50	2297170	49	ELR H5-IES-PT/500AC-9-IFS	2905140	20
DEK-OE- 5DC/ 48DC/100	2940223	440	ELR 1-230AC/600AC-20	2297141	48	ELR H5-IES-PT/500AC-9-IOL	2908670	21
DEK-OE- 12DC/ 48DC/100	2964487	440	ELR 1-230AC/600AC-30	2297167	49	ELR H5-IES-SC- 24DC/500AC-0,6	2900582	24
DEK-OE- 24DC/ 5DC/100KHZ-G	2964364	451	ELR 1-230AC/600AC-50	2297183	49	ELR H5-IES-SC- 24DC/500AC-2	2900414	24
DEK-OE- 24DC/ 24DC/100KHZ	2964283	450	ELR 2+1- 24DC/500AC-37	2297277	43	ELR H5-IES-SC- 24DC/500AC-9	2900421	24
DEK-OE- 24DC/ 24DC/100KHZ-G	2964348	451	ELR 2+1-230AC/500AC-37	2297280	43	ELR H5-IES-SC-230AC/500AC-2	2900420	24
DEK-OE- 24DC/ 48DC/100	2940207	440	ELR 3- 24DC/500AC- 2	2297196	42	ELR H5-IES-SC-230AC/500AC-9	2900422	24
						ELR H5-IES-SC-24DC/500AC-0,6	2900573	25
						ELR H5-I-SC- 24DC/500AC-2	2900574	25
						ELR H5-I-SC- 24DC/500AC-9	2900576	25
						ELR H5-I-SC-230AC/500AC-2	2900575	25
						ELR H5-I-SC-230AC/500AC-9	2900578	25
						ELR H5-I-SC/500AC-06-IFS	2905157	21
						ELR H5-I-SC/500AC-3-IFS	2905159	21
						ELR H5-I-SC/500AC-9-IFS	2905160	21
						ELR H5-IES-PT- 24DC/500AC-0,6	2903902	24
						ELR H5-IES-PT- 24DC/500AC-2	2903904	24
						ELR H5-IES-PT- 24DC/500AC-9	2903906	24
						ELR H5-IES-PT-SWD/500AC-06	2903933	22
						ELR H5-IES-PT-SWD/500AC-3	2903934	22
						ELR H5-IES-PT-SWD/500AC-9	2903935	22
						ELR H5-IES-PT/500AC-06-IFS	2905138	20
						ELR H5-IES-PT/500AC-3-IFS	2905139	20
						ELR H5-IES-PT/500AC-3-IOL	2908669	21
						ELR H5-IES-PT/500AC-9-IFS	2905140	20
						ELR H5-IES-PT/500AC-9-IOL	2908670	21
						ELR H5-IES-SC- 24DC/500AC-0,6	2900582	24

Index

Alphabetical

Type	Order No.	Page	Type	Order No.	Page	Type	Order No.	Page	Type	Order No.	Page
EMG 17-REL/KSR-G 24/2E/SO38	2941646	447	EMG 17-REL/KSR-G 24/SO38 BK	2949994	447	EMG 22-DIO 4E	2950048	280	EMG 22-DIO 4E-1N5408	2952790	280
EMG 22-DIO 4M-1N5408	2952211	280	EMG 22-DIO 4P-1N5408	2952198	280	EMG 22-DIO 7M	2950077	280	EMG 22-DIO 7P	2950064	280
EMG 22-LA 7S/230	2949677	281	EMG 22-LED 7S/24	2952305	281	EMG 22-REL/KSR-230/21/ SO46	2940760	444	EMG 22-REL/KSR-230/21/AU/SO46	2940061	444
EMG 22-REL/KSR-G 24/TRN 5	2949787	454	EMG 22-REL/KSR-G 24/TRN12	2952363	454	EMG 22-REL/KSR-G 24/TRN35	2952350	454	EMG 22-REL/KSR-G 24/TRP 5	2949790	455
EMG 22-REL/KSR-G 24/TRP12	2952156	455	EMG 22-REL/KSR-G 24/TRP35	2952169	455	EMG 30-SP- 4K7LIN	2940252	101	EMG 30-SP-10K LIN	2942124	101
EMG 45-DIO 8E	2950103	280	EMG 45-DIO 8E-1N5408	2949389	280	EMG 45-DIO 8E/LP	2954798	281	EMG 45-DIO 8M-1N5408	2954882	280
EMG 45-DIO 8P-1N5408	2954879	280	EMG 45-DIO14M	2950129	280	EMG 45-DIO14M/LP	2950132	281	EMG 45-DIO14P	2950116	280
EMG 90-DIO 16E/LP	2954808	281	EMG 90-DIO 17E	2954895	280	EMG 90-DIO 32M	2954934	280	EMG 90-DIO 32M/LP	2954785	281
EMG 90-DIO 32P	2954918	280	EMG-GKS 12	2947035	280	EMM 3- 24DC/500AC-16-IFS	2297523	14	EMM 3- 24DC/500AC-IFS	2297497	14
EMM 3- 24DC/500AC-16-IFS	2297536	14	EMM 3-230AC/500AC-16-IFS	2297507	14	EMM 3-230AC/500AC-IFS	2297507	14	ETD-BL-1T-230	2905813	272
ETD-BL-1T-230-PT	2905814	272	ETD-BL-1T-F- 10S	2917492	277	ETD-BL-1T-F- 10S-PT	2901489	277	ETD-BL-1T-F- 30MIN	2917515	277
ETD-BL-1T-F- 30MIN-PT	2901491	277	ETD-BL-1T-F-300MIN	2917528	277	ETD-BL-1T-F-300MIN-PT	2901492	277	ETD-BL-1T-F-300S	2917502	277
ETD-BL-1T-F-300S-PT	2901490	277	ETD-BL-1T-OFF-CC- 10S	2917450	277	ETD-BL-1T-OFF-CC- 10S-PT	2901485	277	ETD-BL-1T-OFF-CC- 30MIN	2917467	277
ETD-BL-1T-OFF-CC-300MIN	2917489	277	ETD-BL-1T-OFF-CC-300MIN-PT	2901488	277	ETD-BL-1T-OFF-CC-300S	2917463	277	ETD-BL-1T-OFF-CC-300S-PT	2901486	277
ETD-BL-1T-ON- 10S	2917379	276	ETD-BL-1T-ON- 10S-PT	2901476	276	ETD-BL-1T-ON- 30MIN	2917395	276	ETD-BL-1T-ON- 30MIN-PT	2901478	276
ETD-BL-1T-ON-300MIN	2917405	276	ETD-BL-1T-ON-300MIN-PT	2901479	276	ETD-BL-1T-ON-300S	2917382	276	ETD-BL-1T-ON-300S-PT	2901477	276
ETD-BL-1T-ON-CC- 10S	2917418	277	ETD-BL-1T-ON-CC- 10S-PT	2901480	277	ETD-BL-1T-ON-CC- 30MIN	2917434	277	ETD-BL-1T-ON-CC- 30MIN-PT	2901483	277
ETD-BL-1T-ON-CC-300MIN	2917447	277	ETD-BL-1T-ON-CC-300MIN-PT	2901484	277	ETD-BL-1T-ON-CC-300S	2917421	277	ETD-BL-1T-ON-CC-300S-PT	2901481	277
ETD-BL-2T-1-230	2907713	273	ETD-BL-2T-1-230-PT	2907714	273	ETD-FL-2T-DTI	2866187	278	ETD-SL-1T-DTF	2866161	279
ETD-SL-2T-1	2866174	279	EU4A-RJ45-USB-CAB1 PXC	2903465	38	EU5C-SWD-CAN PXC	2903098	37	EU5C-SWD-DP PXC	2903100	37
EU5C-SWD-EIP-MODTCCP PXC	2903244	37	EU5C-SWD-PF2-1 PXC	2903113	37	EU5E-SWD-2A2A PXC	2903104	37	EU5E-SWD-4D4D PXC	2903101	37
EU5E-SWD-4DX PXC	2903102	37	EU5E-SWD-X8D PXC	2903103	37	FA MCR-D-TUI-UI-2REL-UP	2907064	180	FA MCR-DS-I-I-OLP	2908781	182
FA MCR-EX-D-TUI-UI-2REL-UP	2907216	180	FA MCR-EX-FD-TUI-UI-2REL-UP	2907781	181	FA MCR-FD-PM	2908739	181	FA MCR-FD-TUI-UI-2REL-UP	2907780	181
FA MCR-FDS-I-I-OLP	2908782	183	FA MCR-FDS-PM	2908783	183	FA MCR-HT-D	2908735	187	FA MCR-HT-FH	2908736	192
FA MCR-HT-FH-PM	2908738	192	FA MCR-HT-FH-WM	2908737	192	FA MCR-HTS-I-OLP-PT	2908742	187	FASTCON PRO-SET	2906227	101
FASTCON PRO-SET-PT	2906228	101	FBS 2-6	3030336	366	FBS 2-6 BU	3036932	366	FBS 2-6 GY	3032237	366
FBS 2-8	3030284	366	FBS 2-8 BU	3030324	366	FBS 2-8 GY	3032541	366	FBS 5-6	3030349	366
FBS 10-6	3030271	366	FBS 20-6	3030365	366	FBSR 4-6	3001595	296	FBSR 5-6	3001596	296
FBSR 6-6	2966812	424	FBSR 6-PLC BU	2966825	424	FBSR 6-PLC RD	2966236	424	FBSR 8-PLC GY	2967688	424
FBSR 14-PLC BK	2967691	424	FBSR 500-PLC BU	2966692	424	FBST 14-PLC BK	2967689	424	FBST 500-PLC RD	2967689	424
FBST 500-PLC GY	2966838	424	FLK 10/EZ-DR/ 50/KONFEK	2299204	588	FLK 10/EZ-DR/ 100/KONFEK	2299217	588	FLK 10/EZ-DR/ 150/KONFEK	2299220	588
FLK 10/EZ-DR/ 200/KONFEK	2299233	588	FLK 10/EZ-DR/ 300/KONFEK	2299246	588	FLK 10/EZ-DR/ 400/KONFEK	2299259	588	FLK 10/EZ-DR/ 600/KONFEK	2299262	588
FLK 10/EZ-DR/ 800/KONFEK	2299275	588	FLK 14/EZ-DR/ 30/KONFEK	2288901	550	FLK 14/EZ-DR/ 50/KONFEK	2288914	550	FLK 14/EZ-DR/ 100/KONFEK	2288927	550
FLK 14/EZ-DR/ 150/KONFEK	2288930	550	FLK 14/EZ-DR/ 200/KONFEK	2288943	550	FLK 14/EZ-DR/ 300/KONFEK	2288956	550	FLK 14/EZ-DR/ 400/KONFEK	2288969	550
FLK 14/EZ-DR/ 500/KONFEK	2288982	550	FLK 14/EZ-DR/ 600/KONFEK	2288995	550	FLK 14/EZ-DR/ 800/KONFEK	2289008	550	FLK 14/EZ-DR/ 1000/KONFEK	2289021	550
FLK 14/EZ-DR/ 1500/KONFEK	2289034	550	FLK 14/EZ-DR/ 2000/KONFEK	2289047	550	FLK 14/EZ-DR/ 3000/KONFEK	2289060	550	FLK 14/EZ-DR/ 4000/KONFEK	2289073	550
FLK 14/EZ-DR/ 5000/KONFEK	2289086	550	FLK 14/EZ-DR/ 6000/KONFEK	2289099	550	FLK 14/EZ-DR/ 8000/KONFEK	2289112	550	FLK 14/EZ-DR/ 10000/KONFEK	2289125	550
FLK 14/EZ-DR/ 15000/KONFEK	2289138	550	FLK 14/EZ-DR/ 20000/KONFEK	2289151	550	FLK 14/EZ-DR/ 30000/KONFEK	2289164	550	FLK 14/EZ-DR/ 40000/KONFEK	2289177	550
FLK 14/EZ-DR/ 50000/KONFEK	2289190	550	FLK 14/EZ-DR/ 60000/KONFEK	2289203	550	FLK 14/EZ-DR/ 80000/KONFEK	2289216	550	FLK 14/EZ-DR/ 100000/KONFEK	2289229	550
FLK 14/EZ-DR/ 150000/KONFEK	2289242	550	FLK 14/EZ-DR/ 200000/KONFEK	2289255	550	FLK 14/EZ-DR/ 300000/KONFEK	2289268	550	FLK 14/EZ-DR/ 400000/KONFEK	2289281	550
FLK 14/EZ-DR/ 500000/KONFEK	2289294	550	FLK 14/EZ-DR/ 600000/KONFEK	2289307	550	FLK 14/EZ-DR/ 800000/KONFEK	2289320	550	FLK 14/EZ-DR/ 1000000/KONFEK	2289333	550
FLK 14/EZ-DR/ 1500000/KONFEK	2289349	550	FLK 14/EZ-DR/ 2000000/KONFEK	2289362	550	FLK 14/EZ-DR/ 3000000/KONFEK	2289375	550	FLK 14/EZ-DR/ 4000000/KONFEK	2289388	550
FLK 14/EZ-DR/ 5000000/KONFEK	2289401	550	FLK 14/EZ-DR/ 6000000/KONFEK	2289414	550	FLK 14/EZ-DR/ 8000000/KONFEK	2289427	550	FLK 14/EZ-DR/ 10000000/KONFEK	2289440	550
FLK 14/EZ-DR/ 15000000/KONFEK	2289453	550	FLK 14/EZ-DR/ 20000000/KONFEK	2289466	550	FLK 14/EZ-DR/ 30000000/KONFEK	2289479	550	FLK 14/EZ-DR/ 40000000/KONFEK	2289492	550
FLK 14/EZ-DR/ 50000000/KONFEK	2289505	550	FLK 14/EZ-DR/ 60000000/KONFEK	2289518	550	FLK 14/EZ-DR/ 80000000/KONFEK	2289531	550	FLK 14/EZ-DR/ 100000000/KONFEK	2289544	550
FLK 14/EZ-DR/ 150000000/KONFEK	2289562	550	FLK 14/EZ-DR/ 200000000/KONFEK	2289575	550	FLK 14/EZ-DR/ 300000000/KONFEK	2289588	550	FLK 14/EZ-DR/ 400000000/KONFEK	2289601	550
FLK 14/EZ-DR/ 500000000/KONFEK	2289618	550	FLK 14/EZ-DR/ 600000000/KONFEK	2289631	550	FLK 14/EZ-DR/ 800000000/KONFEK	2289644	550	FLK 14/EZ-DR/ 1000000000/KONFEK	2289657	550
FLK 14/EZ-DR/ 1500000000/KONFEK	2289673	550	FLK 14/EZ-DR/ 2000000000/KONFEK	2289686	550	FLK 14/EZ-DR/ 3000000000/KONFEK	2289699	550	FLK 14/EZ-DR/ 4000000000/KONFEK	2289712	550
FLK 14/EZ-DR/ 5000000000/KONFEK	2289725	550	FLK 14/EZ-DR/ 6000000000/KONFEK	2289738	550	FLK 14/EZ-DR/ 8000000000/KONFEK	2289751	550	FLK 14/EZ-DR/ 10000000000/KONFEK	2289764	550
FLK 14/EZ-DR/ 15000000000/KONFEK	2289777	550	FLK 14/EZ-DR/ 20000000000/KONFEK	2289790	550	FLK 14/EZ-DR/ 30000000000/KONFEK	2289803	550	FLK 14/EZ-DR/ 40000000000/KONFEK	2289816	550
FLK 14/EZ-DR/ 50000000000/KONFEK	2289832	550	FLK 14/EZ-DR/ 60000000000/KONFEK	2289845	550	FLK 14/EZ-DR/ 80000000000/KONFEK	2289858	550	FLK 14/EZ-DR/ 100000000000/KONFEK	2289871	550
FLK 14/EZ-DR/ 150000000000/KONFEK	2289887	550	FLK 14/EZ-DR/ 200000000000/KONFEK	2289900	550	FLK 14/EZ-DR/ 300000000000/KONFEK	2289913	550	FLK 14/EZ-DR/ 400000000000/KONFEK	2289926	550
FLK 14/EZ-DR/ 500000000000/KONFEK	2289941	550	FLK 14/EZ-DR/ 600000000000/KONFEK	2289954	550	FLK 14/EZ-DR/ 800000000000/KONFEK	2289967	550	FLK 14/EZ-DR/ 1000000000000/KONFEK	2289980	550
FLK 14/EZ-DR/ 1500000000000/KONFEK	2289993	550	FLK 14/EZ-DR/ 2000000000000/KONFEK	2290006	550	FLK 14/EZ-DR/ 3000000000000/KONFEK	2290019	550	FLK 14/EZ-DR/ 4000000000000/KONFEK	2290032	550
FLK 14/EZ-DR/ 5000000000000/KONFEK	2290047	550	FLK 14/EZ-DR/ 6000000000000/KONFEK	2290060	550	FLK 14/EZ-DR/ 8000000000000/KONFEK	2290073	550	FLK 14/EZ-DR/ 10000000000000/KONFEK	2290086	550
FLK 14/EZ-DR/ 15000000000000/KONFEK	2290101	550	FLK 14/EZ-DR/ 20000000000000/KONFEK	2290114	550	FLK 14/EZ-DR/ 30000000000000/KONFEK	2290127	550	FLK 14/EZ-DR/ 40000000000000/KONFEK	2290140	550
FLK 14/EZ-DR/ 50000000000000/KONFEK	2290155	550	FLK 14/EZ-DR/ 60000000000000/KONFEK	2290168	550	FLK 14/EZ-DR/ 80000000000000/KONFEK	2290181	550	FLK 14/EZ-DR/ 100000000000000/KONFEK	2290194	550
FLK 14/EZ-DR/ 150000000000000/KONFEK	2290209	550	FLK 14/EZ-DR/ 200000000000000/KONFEK	2290222	550	FLK 14/EZ-DR/ 300000000000000/KONFEK	2290235	550	FLK 14/EZ-DR/ 400000000000000/KONFEK	2290248	550
FLK 14/EZ-DR/ 500000000000000/KONFEK	2290263	550	FLK 14/EZ-DR/ 600000000000000/KONFEK	2290276	550	FLK 14/EZ-DR/ 800000000000000/KONFEK	2290289	550	FLK 14/EZ-DR/ 1000000000000000/KONFEK	2290302	550
FLK 14/EZ-DR/ 1500000000000000/KONFEK	2290317	550	FLK 14/EZ-DR/ 2000000000000000/KONFEK	2290330	550	FLK 14/EZ-DR/ 3000000000000000/KONFEK	2290343	550	FLK 14/EZ-DR/ 4000000000000000/KONFEK	2290356	550
FLK 14/EZ-DR/ 5000000000000000/KONFEK	2290371	550	FLK 14/EZ-DR/ 6000000000000000/KONFEK	2290384	550	FLK 14/EZ-DR/ 8000000000000000/KONFEK	2290397	550	FLK 14/EZ-DR/ 10000000000000000/KONFEK	2290410	550
FLK 14/EZ-DR/ 15000000000000000/KONFEK	2290425	550	FLK 14/EZ-DR/ 20000000000000000/KONFEK	2290438	550	FLK 14/EZ-DR/ 30000000000000000/KONFEK	2290451	550	FLK 14/EZ-DR/ 40000000000000000/KONFEK	2290464	550
FLK 14/EZ-DR/ 50000000000000000/KONFEK	2290477	550	FLK 14/EZ-DR/ 60000000000000000/KONFEK	2290490	550	FLK 14/EZ-DR/ 80000000000000000/KONFEK	2290503	550	FLK 14/EZ-DR		

Type	Order No.	Page	Type	Order No.	Page	Type	Order No.	Page	Type	Order No.	Page
FLK 50-PA/EZ-DR/KS/2000/YUC	2314503	516	FLKM 16-PA- 332-5HF/I/MINI-MCR	2318240	507	MACX MCR-EX-SL-TC-I-NC	2865586	146	MACX MCR-EX-SL-TC-I-NC	2865586	146
FLK 50-PA/EZ-DR/KS/2500/YUC	2314516	516	FLKM 16-PA-S300/MINI-MCR	2314749	506	MACX MCR-EXT-UI-UP	2865654	148	MACX MCR-EXT-UI-UP	2865654	148
FLK 50-PA/EZ-DR/KS/3000/YUC	2314529	516	FLKM 16/AI/DV	2304429	481	MACX MCR-EXT-UI-UP-C	2811763	148	MACX MCR-EXT-UI-UP-C	2811763	148
FLK 50/2FLK20/EZ-DR/ 50/DV	2304872	480	FLKM 16/AO/SI/DV	2304445	481	MACX MCR-EXT-UI-UP-SP	2924689	148	MACX MCR-EXT-UI-UP-SP	2924689	148
FLK 50/2FLK20/EZ-DR/ 100/DV	2304898	480	FLKM 16/DV	2304432	481	MACX MCR-EXT-UI-UP-SP-C	2924692	148	MACX MCR-EXT-UI-UP-SP-C	2924692	148
FLK 50/2FLK20/EZ-DR/ 200/DV	2304908	480	FLKM 4X14-PA/AN/S7-1500	2907385	511	MACX MCR-EXT-UIREL-UP	2865751	150	MACX MCR-EXT-UIREL-UP	2865751	150
FLK 50/2FLK20/EZ-DR/ 300/DV	2304911	480	FLKM 4X14-PA/PT/DIO/S7-1500	2907382	510	MACX MCR-EXT-UIREL-UP-SP	2924799	150	MACX MCR-EXT-UIREL-UP-SP	2924799	150
FLK 50/2FLK20/EZ-DR/ 600/DV	2304937	480	FLKM 4X14-PA/SC/DIO/S7-1500	2907381	510	MACX MCR-I20	2905680	139	MACX MCR-I20	2905680	139
FLK 50/2FLK20/EZ-DR/ 800/DV	2304940	480	FLKM 50-PA-AB/1756/EXTC	2302735	472	MACX MCR-PTB	2865625	174	MACX MCR-PTB	2865625	174
FLK 50/2FLK20/EZ-DR/ 1000/DV	2304953	480	FLKM 50-PA-AB/1756/IN/EXTC	2302748	472	MACX MCR-PTB-SP	2924184	174	MACX MCR-PTB-SP	2924184	174
FLK 50/4X14/EZ-DR/ 50/KONFEK	2296689	551	FLKM 50-PA-GE/TKFC/RXI	2321473	484	MACX MCR-S-MUX	2865599	166	MACX MCR-S-MUX	2865599	166
FLK 50/4X14/EZ-DR/ 100/KONFEK	2296692	551	FLKM 50-PA-GE/TKFC/RXI/IN	2321486	484	MACX MCR-S-MUX-TB	2308124	166	MACX MCR-S-MUX-TB	2308124	166
FLK 50/4X14/EZ-DR/ 150/KONFEK	2296702	551	FLKM 50-PA-MODI-TSX/Q	2294306	493	MACX MCR-SL-2I-2I-HV-ILP	2907706	125	MACX MCR-SL-2I-2I-HV-ILP	2907706	125
FLK 50/4X14/EZ-DR/ 200/KONFEK	2296715	551	FLKM 50-PA-S300	2294455	502	MACX MCR-SL-2I-2I-HV-ILP-SP	2907707	125	MACX MCR-SL-2I-2I-HV-ILP-SP	2907707	125
FLK 50/4X14/EZ-DR/ 250/KONFEK	2305402	551	FLKM 50-PA-S300/SO167	2307662	504	MACX MCR-SL-2I-2I-ILP	2905280	124	MACX MCR-SL-2I-2I-ILP	2905280	124
FLK 50/4X14/EZ-DR/ 300/KONFEK	2296728	551	FLKM 50-PA-S400	2294500	514	MACX MCR-SL-2I-2I-ILP-SP	2905281	124	MACX MCR-SL-2I-2I-ILP-SP	2905281	124
FLK 50/4X14/EZ-DR/ 400/KONFEK	2296731	551	FLKM 50-PA-S400(3-48)	2294908	515	MACX MCR-SL-2NAM-R-UP	2865052	135	MACX MCR-SL-2NAM-R-UP	2865052	135
FLK 50/4X14/EZ-DR/ 600/KONFEK	2299077	550	FLKM 50-PA-SLC500/OUT/2A	2293446	476	MACX MCR-SL-2NAM-R-UP-SP	2924304	135	MACX MCR-SL-2NAM-R-UP-SP	2924304	135
FLK 50/4X14/EZ-DR/ 800/KONFEK	2296757	551	FLKM 50-PA/AN/S7-1500	2907386	511	MACX MCR-SL-2NAM-RO	2865049	134	MACX MCR-SL-2NAM-RO	2865049	134
FLK 50/4X14/EZ-DR/1000/KONFEK	2296773	551	FLKM 50-PA/DO326/S7-300	2321952	504	MACX MCR-SL-2NAM-RO-SP	2924294	134	MACX MCR-SL-2NAM-RO-SP	2924294	134
FLK 50/EZ-DR/ 50/KONFEK	2289065	550	FLKM 50-PA/PT/DIO/S7-1500	2907384	510	MACX MCR-SL-2NAM-T	2865036	137	MACX MCR-SL-2NAM-T	2865036	137
FLK 50/EZ-DR/ 50/KONFEK/S	2299097	550	FLKM 50-PA/SC/DIO/S7-1500	2907383	510	MACX MCR-SL-2NAM-R-UP-SP	2924281	137	MACX MCR-SL-2NAM-R-UP-SP	2924281	137
FLK 50/EZ-DR/ 100/KONFEK	2289078	550	FLKM 50/ 4-FLK14/PA-MODI-TSX/Q	2294416	493	MACX MCR-SL-CAC- 5-I	2810612	246	MACX MCR-SL-CAC- 5-I	2810612	246
FLK 50/EZ-DR/ 100/KONFEK/S	2299107	550	FLKM 50/ 4-FLK14/PA-S400	2294429	515	MACX MCR-SL-CAC- 5-I-UP	2810625	246	MACX MCR-SL-CAC- 5-I-UP	2810625	246
FLK 50/EZ-DR/ 150/KONFEK	2289081	550	FLKM 50/32M/DV	2304869	482	MACX MCR-SL-CAC-12-I-UP	2810638	246	MACX MCR-SL-CAC-12-I-UP	2810638	246
FLK 50/EZ-DR/ 150/KONFEK/S	2299110	550	FLKM 50/32M/IN/LA/DV	2304856	482	MACX MCR-SL-I-HV-ILP	2907704	125	MACX MCR-SL-I-HV-ILP	2907704	125
FLK 50/EZ-DR/ 200/KONFEK	2289094	550	FLKM 50/32M/PLC	2289719	529	MACX MCR-SL-I-HV-ILP-SP	2907705	125	MACX MCR-SL-I-HV-ILP-SP	2907705	125
FLK 50/EZ-DR/ 200/KONFEK/S	2299123	550	FLKM 50/32M/SI/PLC	2294490	530	MACX MCR-SL-I-HV-ILP-SP	2905278	124	MACX MCR-SL-I-HV-ILP-SP	2905278	124
FLK 50/EZ-DR/ 250/KONFEK	2289104	550	FLKM 50/32P/PLC	2291121	529	MACX MCR-SL-I-HV-ILP-SP	2905279	124	MACX MCR-SL-I-HV-ILP-SP	2905279	124
FLK 50/EZ-DR/ 300/KONFEK	2289117	550	FLKM 50/4-FLK14/PA-S300	2296281	502	MACX MCR-SL-IDSH	2865971	126	MACX MCR-SL-IDSH	2865971	126
FLK 50/EZ-DR/ 300/KONFEK/S	2299136	550	FLKM 50/KDS3-MT/PPA/AN/PLC	2291587	534	MACX MCR-SL-IDSH-SP	2924223	126	MACX MCR-SL-IDSH-SP	2924223	126
FLK 50/EZ-DR/ 350/KONFEK	2289120	550	FLKM 50/KDS3-MT/PPA/PLC	2296114	534	MACX MCR-SL-NAM-2RO	2865010	133	MACX MCR-SL-NAM-2RO	2865010	133
FLK 50/EZ-DR/ 400/KONFEK	2289133	550	FLKM 50/KDS3-MT/PPA/S7-300	2304490	534	MACX MCR-SL-NAM-2RO-SP	2924265	133	MACX MCR-SL-NAM-2RO-SP	2924265	133
FLK 50/EZ-DR/ 400/KONFEK/S	2299149	550	FLKM S115-454-7LA/S400	2314901	562	MACX MCR-SL-NAM-2T	2865023	136	MACX MCR-SL-NAM-2T	2865023	136
FLK 50/EZ-DR/ 450/KONFEK	2289573	550	FLKM S115/47X0,75/3,0M/OE	2314985	563	MACX MCR-SL-NAM-2T-SP	2924278	136	MACX MCR-SL-NAM-2T-SP	2924278	136
FLK 50/EZ-DR/ 500/KONFEK	2289586	550	FLKM S115/47X0,75/5,0M/OE	2314998	563	MACX MCR-SL-NAM-R	2865997	132	MACX MCR-SL-NAM-R	2865997	132
FLK 50/EZ-DR/ 550/KONFEK	2289599	550	FLKM S115/S400/SO155	2307248	562	MACX MCR-SL-NAM-R-SP	2924252	132	MACX MCR-SL-NAM-R-SP	2924252	132
FLK 50/EZ-DR/ 600/KONFEK	2289609	550	FLKM S115/S7/FLK50/PLC/SO137	2306294	563	MACX MCR-SL-NAM-R-SP	2904089	123	MACX MCR-SL-NAM-R-SP	2904089	123
FLK 50/EZ-DR/ 600/KONFEK/S	2299152	550	FLKM S135-431-4UA/S400	2314846	560	MACX MCR-SL-RPSS-2I-2I	2904090	123	MACX MCR-SL-RPSS-2I-2I	2904090	123
FLK 50/EZ-DR/ 650/KONFEK	2289612	550	FLKM S135-454-4UA/S400	2314859	561	MACX MCR-SL-RPSS-2I-2I-SP	2924825	121	MACX MCR-SL-RPSS-2I-2I-SP	2924825	121
FLK 50/EZ-DR/ 700/KONFEK	2289625	550	FLKM S135-460-4UA/I/S400	2314613	561	MACX MCR-SL-RPSS-2I-SP	2924838	121	MACX MCR-SL-RPSS-2I-SP	2924838	121
FLK 50/EZ-DR/ 750/KONFEK	2289638	550	FLKM S135-460-4UA/U/S400	2314862	561	MACX MCR-SL-RPSS-I	2865955	120	MACX MCR-SL-RPSS-I	2865955	120
FLK 50/EZ-DR/ 800/KONFEK	2289641	550	FLKM S135-465-4UA/T/S400	2314875	561	MACX MCR-SL-RPSS-I-SP	2924207	120	MACX MCR-SL-RPSS-I-SP	2924207	120
FLK 50/EZ-DR/ 800/KONFEK/S	2299165	550	FLKM S135-465-4UA/U/S400	2314888	561	MACX MCR-SL-RPSS-I-UP	2865968	122	MACX MCR-SL-RPSS-I-UP	2865968	122
FLK 50/EZ-DR/ 850/KONFEK	2289654	550	FLKM S135-470-4UC/I/S400	2314626	561	MACX MCR-SL-RPSS-I-UP-SP	2924210	122	MACX MCR-SL-RPSS-I-UP-SP	2924210	122
FLK 50/EZ-DR/ 900/KONFEK	2289667	550	FLKM S135-470-4UC/U/S400	2314891	561	MACX MCR-SL-RTD-I	2865065	130	MACX MCR-SL-RTD-I	2865065	130
FLK 50/EZ-DR/ 950/KONFEK	2289670	550	FLKM S135/42X0,75/3,0M/OE	2315007	559	MACX MCR-SL-RTD-I-NC	2865078	130	MACX MCR-SL-RTD-I-NC	2865078	130
FLK 50/EZ-DR/1000/KONFEK	2289683	550	FLKM S135/42X0,75/5,0M/OE	2318017	559	MACX MCR-SL-RTD-I-SP	2924317	130	MACX MCR-SL-RTD-I-SP	2924317	130
FLK 50/EZ-DR/1000/KONFEK/S	2299178	550	FLKM S135/42XMKDSN	2901603	559	MACX MCR-SL-RTD-I-SP-NC	2924320	130	MACX MCR-SL-RTD-I-SP-NC	2924320	130
FLK 50/EZ-DR/D37SUB/ 50/X81-I	2302641	488	FLKM S135/S400/SO120	2301723	560	MACX MCR-SL-TC-I	2924333	131	MACX MCR-SL-TC-I	2924333	131
FLK 50/EZ-DR/D37SUB/ 50/Y81P-O	2302599	488	FLKM S135/S400/SO121	2301736	560	MACX MCR-SL-TC-I-NC	2924346	131	MACX MCR-SL-TC-I-NC	2924346	131
FLK 50/EZ-DR/D37SUB/100/X81-I	2302654	488	FLKM S135/S400/SO122	2301749	560	MACX MCR-T-UI-UP	2811394	128	MACX MCR-T-UI-UP	2811394	128
FLK 50/EZ-DR/D37SUB/100/Y81P-O	2302609	488	FLKM S135/S400/SO125	2301778	561	MACX MCR-T-UI-UP-C	2811873	128	MACX MCR-T-UI-UP-C	2811873	128
FLK 50/EZ-DR/D37SUB/200/X81-I	2302667	488	FLKM S135/S400/SO126	2301781	561	MACX MCR-T-UI-UP-SP	2811860	128	MACX MCR-T-UI-UP-SP	2811860	128
FLK 50/EZ-DR/D37SUB/200/Y81P-O	2302612	488	FLKM S135/S400/SO127	2301794	561	MACX MCR-T-UI-UP-SP-C	2811970	128	MACX MCR-T-UI-UP-SP-C	2811970	128
FLK 50/EZ-DR/D37SUB/300/X81-I	2302670	488	FLKM S135/S7/FLK50/PLC	2314736	559	MACX MCR-T-UIREL-UP	2811378	127	MACX MCR-T-UIREL-UP	2811378	127
FLK 50/EZ-DR/D37SUB/300/Y81P-O	2302638	488	FLKM-2FLK14/KDS3-MT/PPA/S7	2295062	534	MACX MCR-T-UIREL-UP-SP	2811828	127	MACX MCR-T-UIREL-UP-SP	2811828	127
FLK 50/EZ-DR/FCN40/100/OMR-OUT	2304160	490	FLKM-D25 SUB/B/KDS3-MT/TU810	2304513	470	MACX MCR-TS-I-OLP	2908664	194	MACX MCR-TS-I-OLP	2908664	194
FLK 50/EZ-DR/FCN40/100/OMR-IN	2304144	490	FLKM-D25 SUB/B/KDS3-MT/TU810P	2304539	470	MACX MCR-TS-I-OLP-SP	2908664	194	MACX MCR-TS-I-OLP-SP	2908664	194
FLK 50/EZ-DR/FCN40/200/OMR-IN	2304173	490	FLKM-D25 SUB/B/KDS3-MT/TU830	2304526	470	MACX MCR-TS-I-OLP-SP	2811284	116	MACX MCR-TS-I-OLP-SP	2811284	116
FLK 50/EZ-DR/FCN40/200/OMR-OUT	2304157	490	FLKM-KS40/AO16/YCS	2314260	521	MACX MCR-TS-I-OLP-SP	2811446	116	MACX MCR-TS-I-OLP-SP	2811446	116
FLK EZ-DR-S-.../.../...	2295046	591	FLKM-KS40/YCS	2314642	520	MACX MCR-TS-I-OLP-SP	2811572	116	MACX MCR-TS-I-OLP-SP	2811572	116
FLK EZ-DR-S-.../.../...	2295059	591	FLKM-PA-2D15/HW/DI/C300	2901879	486	MACX MCR-TS-I-OLP-SP	2811556	116	MACX MCR-TS-I-OLP-SP	2811556	116
FLKM 14-PA-AB/1756/EXTC	2302861	473	FLKM-PA-2D15/HW/DO/C300	2909024	486	MACX MCR-TS-I-OLP-SP	2811459	118	MACX MCR-TS-I-OLP-SP	2811459	118
FLKM 14-PA-AB/1756/IF6/EXTC	2901037	473	FLKM-PA-D37/HW/AN/C300	2906022	486	MACX MCR-TS-I-OLP-SP	2811297	118	MACX MCR-TS-I-OLP-SP	2811297	118
FLKM 14-PA-AB/1756/IN/EXTC	2302874	473	FLKM-PA-D37/HW/DIO/C300	2901423	486	MACX MCR-TS-I-OLP-SP	2811585	118	MACX MCR-TS-I-OLP-SP	2811585	118
FLKM 14-PA-INLINE/32	2302777	492	FLKMS 50/32IM/LA/PLC	2284510	532	MACX MCR-TS-I-OLP-SP	2811569	118	MACX MCR-TS-I-OLP-SP	2811569	118
FLKM 14-PA-INLINE/DIO8	2900889	492	FLKMS 50/32IM/PLC	2284523	532	MACX MCR-TS-I-OLP-SP	2906239	250	MACX MCR-TS-I-OLP-SP	2906239	250
FLKM 14-PA-INLINE/IN16	2										

Index

Alphabetical

Type	Order No.	Page	Type	Order No.	Page	Type	Order No.	Page	Type	Order No.	Page
MACX PL-TUIREL-UP-SP	2904903	139	MINI MCR-2-T-REL-PT	2905633	92				PACT MCR-V2-6015-85-250-5A-1	2277886	227
MC 1,5/5-ST-3,81	1803604	14	MINI MCR-2-TB	2902068	104				PACT MCR-V2-6015-85-300-5A-1	2277899	227
MCR-DIN-RAIL-ADAPTER HT	2864671	193	MINI MCR-2-TC-UI	2902055	82				PACT MCR-V2-6015-85-400-5A-1	2277909	227
MCR-ET 38X35 WH	2814317	251	MINI MCR-2-TC-UI-C	2902053	82				PACT MCR-V2-6015-85-500-5A-1	2277912	227
						P					
MCR-FL-HT-FI	2864529	189	MINI MCR-2-TC-UI-PT	2905249	82	PACT MCR-CB-21-8	2277569	233	PACT MCR-V2-6015-85-600-5A-1	2277925	227
MCR-FL-HT-FI-EX	2864532	190	MINI MCR-2-TC-UI-PT-C	2905248	82	PACT MCR-CB-21-12	2277556	233	PACT MCR-V2-6015-85-750-5A-1	2277938	227
MCR-FL-HT-TS-I-EX	2864545	188	MINI MCR-2-U-I0	2902022	74	PACT MCR-CB-28-12	2277543	233	PACT MCR-V2-6015-85-800-5A-1	2277941	227
MCR-FL-T-LP-I	2864561	196	MINI MCR-2-U-I0-PT	2902023	74	PACT MCR-CB-42-12	2277530	233	PACT MCR-V2-6015-85-1000-5A-1	2277954	227
MCR-FL-T-LP-I-EX	2864574	195	MINI MCR-2-U-I4	2902029	74	PACT MCR-ETC-60	2277572	233	PACT MCR-V2-6015-85-1250-5A-1	2277967	227
MCR-FL-TS-LP-I-EX	2864587	195	MINI MCR-2-U-I4-PT	2902030	74	PACT MCR-ETC-75	2277585	233	PACT MCR-V2-6015-85-1600-5A-1	2277983	227
MCR-PAC-T-USB	2309000	180	MINI MCR-2-U-U	2902042	74	PACT MCR-ICAP	2277608	233	PACT MCR-V2-6040-96-600-5A-1	2276191	228
MCR-S-1-5-UI-DCI	2814634	242	MINI MCR-2-U-U-PT	2902043	74	PACT MCR-RA	2277598	233	PACT MCR-V2-6040-96-750-5A-1	2276201	228
MCR-S-1-5-UI-DCI-NC	2814715	242	MINI MCR-2-UI-FRO	2902031	86	PACT MCR-V1-21-44	2277268	223	PACT MCR-V2-6040-96-800-5A-1	2276214	228
MCR-S-1-5-UI-SW-DCI	2814650	242	MINI MCR-2-UI-FRO-C	2902020	86	PACT MCR-V1-21-44-50-5A-1	2277019	223	PACT MCR-V2-6040-96-1000-5A-1	2277705	228
MCR-S-1-5-UI-SW-DCI-NC	2814731	242	MINI MCR-2-UI-FRO-PT	2902032	86	PACT MCR-V1-21-44-75-5A-1	2277611	223	PACT MCR-V2-6040-96-1250-5A-1	2276227	228
MCR-S-10-50-UI-DCI	2814647	243	MINI MCR-2-UI-FRO-PT-C	2902022	86	PACT MCR-V1-21-44-100-5A-1	2277022	223	PACT MCR-V2-6040-96-1500-5A-1	2277718	228
MCR-S-10-50-UI-SW-DCI	2814663	243	MINI MCR-2-UH-OLP	2902061	79	PACT MCR-V1-21-44-125-5A-1	2277763	223	PACT MCR-V2-6040-96-1600-5A-1	2276230	228
MCR-S-20-100-UI-DCI	2808798	243	MINI MCR-2-UH-OLP-C	2902060	79	PACT MCR-V1-21-44-150-5A-1	2277035	223	PACT MCR-V2-6040-96-2000-5A-1	2276243	228
MCR-S10-50-UI-DCI-NC	2814728	243	MINI MCR-2-UH-OLP-PT	2902063	79	PACT MCR-V1-21-44-200-5A-1	2277776	223	PACT MCR-V2-6315-95-800-5A-1	2277213	228
MCR-S10-50-UI-SW-DCI-NC	2814744	243	MINI MCR-2-UH-OLP-PT-C	2902062	79	PACT MCR-V1-21-44-250-5A-1	2277048	223	PACT MCR-V2-6315-95-1000-5A-1	2277226	228
MCR-SL-CUC-100-I	2308027	241	MINI MCR-2-UI-REL	2902033	91	PACT MCR-V1-21-44-300-5A-1	2277789	223	PACT MCR-V2-6315-95-1250-5A-1	2277239	228
MCR-SL-CUC-100-U	2308108	240	MINI MCR-2-UI-REL-PT	2902035	91	PACT MCR-V1-21-44-400-5A-1	2277051	223	PACT MCR-V2-6315-95-1500-5A-1	2277242	228
MCR-SL-CUC-200-I	2308030	241	MINI MCR-2-UI-UI	2902037	72	PACT MCR-V1-21-44-500-5A-1	2277792	223	PACT MCR-V2-6315-95-1600-5A-1	2277255	228
MCR-SL-CUC-200-U	2308205	240	MINI MCR-2-UI-UI-C	2902036	72	PACT MCR-V1C-21-44	2277420	223	PACT MCR-V2-8015-105-400-5A-1	2276256	229
MCR-SL-CUC-300-I	2308043	241	MINI MCR-2-UI-UI-PT	2902040	72	PACT MCR-V2-3015-60	2277271	224	PACT MCR-V2-8015-105-500-5A-1	2276269	229
MCR-SL-CUC-300-U	2308302	240	MINI MCR-2-UI-UI-PT-C	2902039	72	PACT MCR-V2-3015-60-75-5A-1	2276502	224	PACT MCR-V2-8015-105-600-5A-1	2276272	229
MCR-SL-CUC-400-I	2308072	241	MINI MCR-2-UNI-UI-2UI	2905026	76	PACT MCR-V2-3015-60-150-5A-1	2277077	224	PACT MCR-V2-8015-105-750-5A-1	2276285	229
MCR-SL-CUC-500-I	2308085	241	MINI MCR-2-UNI-UI-2UI-C	2905025	76	PACT MCR-V2-3015-60-250-5A-1	2276544	224	PACT MCR-V2-8015-105-800-5A-1	2276298	229
MCR-SL-CUC-600-I	2308098	241	MINI MCR-2-UNI-UI-2UI-PT	2905028	76	PACT MCR-V2-3015-60-250-5A-1	2277080	224	PACT MCR-V2-8015-105-1000-5A-1	2277721	229
MCR-SL-D-FIT	2864024	185	MINI MCR-2-UNI-UI-2UI-PT-C	2905027	76	PACT MCR-V2-3015-60-400-5A-1	2277093	224	PACT MCR-V2-8015-105-1000-5A-1	2276308	229
MCR-SL-D-RA	2810081	184	MINI MCR-2-UNI-UI-UIRO	2902026	70	PACT MCR-V2-4012-70	2277284	225	PACT MCR-V2-8015-105-1250-5A-1	2276311	229
MCR-SL-D-SPA-UI	2710314	186	MINI MCR-2-UNI-UI-UIRO-C	2902024	70	PACT MCR-V2-5012-85	2277297	226	PACT MCR-V2-8015-105-1500-5A-1	2277734	229
MCR-SL-D-U-I	2864011	184	MINI MCR-2-UNI-UI-UIRO-PT	2902028	70	PACT MCR-V2-6015-85	2277336	227	PACT MCR-V2-8015-105-1600-5A-1	2276324	229
MCR-SL-HTPT 100-I	2864516	191	MINI MCR-2-UNI-UI-UIRO-PT-C	2902027	70	PACT MCR-V2-6040-96	2277349	228	PACT MCR-V2-8015-105-2000-5A-1	2276337	229
MCR-SL-PT100-LP-I	2864558	197	MINI MCR-2-V8-FLK 16	2901993	97	PACT MCR-V2-6315-95	2277307	228	PACT MCR-V2-8015-105-2500-5A-1	2276340	229
MCR-SL-S-16-SP-24	2864464	249	MINI MCR-2-V8-MOD-RTU	2905634	96	PACT MCR-V2-8015-105	2277352	229	PACT MCR-V2-8020-105-1000-5A-1	2277477	229
MCR-SL-S-100-I-LP	2813486	247	MINI MCR-2-V8-MOD-TCP	2905635	96	PACT MCR-V2-8020-105	2277355	229	PACT MCR-V2-8020-105-1500-5A-1	2277750	229
MCR-SL-S-100-U	2813457	247	MINI MCR-2-V8-PB-DP	2905636	96	PACT MCR-V2-10020-129	2277378	230	PACT MCR-V2-8020-105-2000-5A-1	2276382	229
MCR-SL-S-200-I-LP	2813499	247	MINI MCR-SL-FM-RC-NC	2902961	524	PACT MCR-V2-10020-129-2500-5A	2276395	230	PACT MCR-V2C-3015-60	2277433	224
MCR-SL-S-200-U	2813460	247	MINI MCR-SL-PTB-FM	2902958	524	PACT MCR-V2-10036-129	2277381	230	PACT MCR-V2C-4012-70	2277446	225
MCR-SLP-1-5-UI-0	2814359	248	MINI-PS-100-240AC/24DC/1,5/EX	2866653	103	PACT MCR-V2-10036-129-3000-5A	2276405	230	PACT MCR-V2C-5012-85	2277459	226
MCR-TTL-RS232-E	2814388	251	MINI-SYS-PS-100-240AC/24DC/1,5	2866983	103	PACT MCR-V2-12020-159	2277394	231	PACT MCR-V2C-6015-85	2277462	227
MCR/PI-CONF-WIN	2814799	251	MM-CONF-SET	2297992	14	PACT MCR-V2-12040-159	2277404	231	PACT MCR-V2C-6040-96	2277488	228
ME 17,5 TBUS 1,5/5-ST-3,81 GN	2709561	103	MPS-IH BK	0201731	176	PACT MCR-V2-12040-159-4000-5A	2276418	231	PACT MCR-V2C-6315-95	2277475	228
ME 22,5 TBUS 1,5/5-ST-3,81 GN	2707437	433	MPS-IH BU	0201689	176	PACT MCR-V2-3015-60-60-5A-1	2277815	224	PACT MCR-V2C-8015-105	2277491	229
ME 6,2 TBUS-2 1,5/5-ST-3,81 GN	2869728	102	MPS-IH GN	0201702	176	PACT MCR-V2-3015-60-75-5A-1	2277828	224	PACT MCR-V2C-8020-105	2277501	229
ME 6,2 TBUS-2 1,5/5-ST-3,81 GY	2869539	102	MPS-IH GY	0201728	176	PACT MCR-V2-3015-60-80-5A-1	2277831	224	PACT MCR-V2C-10020-129	2277514	230
MINI MCR-2-2I-2H-LP	2901996	78	MPS-IH RD	0201676	176	PACT MCR-V2-3015-60-100-5A-1	2277064	224	PACT MCR-V2C-10036-129	2277527	230
MINI MCR-2-2I-2H-LP-PT	2901997	78	MPS-IH WH	0201663	176	PACT MCR-V2-3015-60-125-5A-1	2277624	224	PACT MCR-V3-60	2277417	232
MINI MCR-2-CVCS	2902064	100	MPS-IH YE	0201692	176	PACT MCR-V2-3015-60-150-5A-1	2277844	224	PACT RCP-4000A-1A-D140	2904922	236
MINI MCR-2-CVCS-PT	2902065	100	MPS-MT	0201744	176	PACT MCR-V2-3015-60-200-5A-1	2277637	224	PACT RCP-4000A-1A-D190	2904923	236
MINI MCR-2-F-UI	2902056	84				PACT MCR-V2-3015-60-200-5A-1	2277857	224	PACT RCP-4000A-1A-D95	2904921	236
MINI MCR-2-F-UI-PT	2902058	84				PACT MCR-V2-3015-60-250-5A-1	2277860	224	PACT RCP-4000A-UIRO-D140	2906232	237
MINI MCR-2-FM-RC	2904504	104				PACT MCR-V2-3015-60-300-5A-1	2277640	224	PACT RCP-4000A-UIRO-D190	2906233	237
MINI MCR-2-FM-RC-PT	2904508	104	N			PACT MCR-V2-3015-60-500-5A-1	2277653	224	PACT RCP-4000A-UIRO-D95	2906231	237
MINI MCR-2-I-I	2901998	74	NFC-USB-PROG-ADAPTER	2900013	105	PACT MCR-V2-3015-60-600-5A-1	2277103	224	PACT RCP-4000A-UIRO-PT-D140	2906235	237
MINI MCR-2-I-HLP	2901994	78				PACT MCR-V2-3015-60-750-5A-1	2277666	224	PACT RCP-4000A-UIRO-PT-D190	2906236	237
MINI MCR-2-I-HLP-PT	2901995	78				PACT MCR-V2-4012-70-250-5A-1	2277116	225	PACT RCP-4000A-UIRO-PT-D95	2906234	237
MINI MCR-2-I-I-PT	2901999	74				PACT MCR-V2-4012-70-300-5A-1	2277679	225	PACT RCP-CLAMP	2904895	236
MINI MCR-2-I0-U	2902000	74				PACT MCR-V2-4012-70-400-5A-1	2277129	225	PACT RCP-CLAMP-5-10	2907888	236
MINI MCR-2-I0-U-PT	2902001	74				PACT MCR-V2-4012-70-500-5A-1	2277682	225	PACT-FAST-MNT-W13-L40	2276612	233
MINI MCR-2-I4-U	2902002	74	O			PACT MCR-V2-4012-70-600-5A-1	2277132	225	PACT-FAST-MNT-W13-L65	2276625	233
MINI MCR-2-I4-U-PT	2902003	74	OPT-5DC/24DC/ 2	2967989	394	PACT MCR-V2-4012-70-750-5A-1	2277695	225	PACT-FAST-MNT-W16-L40	2276638	233
MINI MCR-2-NAM-2RO	2902004	90	OPT-5DC/24DC/ 5	2982113	310	PACT MCR-V2-4012-70-800-5A-1	2277145	225	PACT-FAST-MNT-W16-L65	2276641	233
MINI MCR-2-NAM-2RO-PT	2902005	90	OPT-5DC/48DC/100	2967992	394	PACT MCR-V2-401					

Type	Order No.	Page	Type	Order No.	Page	Type	Order No.	Page	Type	Order No.	Page
PLC-BPT-TTL/1	2900458	412	PLC-OSC-24DC/230AC/ 1	2967840	377	PLC-RPT-60DC/21-21	2900334	374	PLC-RSC-60DC/21-21	2967293	374
PLC-BSC-24UC/ 1/ACT	2982799	383	PLC-OSC-24DC/230AC/ 1/ACT	2967947	381	PLC-RPT-60DC/21-21AU	2900341	375	PLC-RSC-60DC/21-21AU	2967303	375
PLC-BSC-120UC/ 1/SEN/SO46	2980322	389	PLC-OSC-24DC/230AC/ 2/ACT	2982760	382	PLC-RPT-60DC/21AU	2900309	373	PLC-RSC-60DC/21AU	2966142	373
PLC-BSC-120UC/21-21/SO46	2980416	389	PLC-OSC-24DC/230AC/2.4/ACT	2904631	408	PLC-RPT-60DC/21HC	2900295	387	PLC-RSC-60DC/21HC	2967659	387
PLC-BSC-120UC/21/SO46	2980319	388	PLC-OSC-24DC/300DC/ 1	2980678	406	PLC-RPT-72UC/21-21/RW	2900347	419	PLC-RSC-120UC/ 1AU/MS/SEN	2909664	385
PLC-BSC-120UC/21HC/SO46	2980432	389	PLC-OSC-24DC/TTL	2982728	414	PLC-RPT-72UC/21-21AU/RW	2900350	419	PLC-RSC-120UC/ 1AU/SEN	2966320	384
PLC-BSC-230UC/ 1/SEN/SO46	2980348	389	PLC-OSC-48DC/ 24DC/ 2	2967002	377	PLC-RPT-72UC/21/RW	2900319	418	PLC-RSC-120UC/21	2966197	372
PLC-BSC-230UC/21-21/SO46	2980429	389	PLC-OSC-48DC/ 48DC/100	2966993	376	PLC-RPT-72UC/21AU/RW	2900322	418	PLC-RSC-120UC/21-21	2967086	374
PLC-BSC-230UC/21/SO46	2980335	388	PLC-OSC-48DC/230AC/ 1	2967853	377	PLC-RPT-72UC/21HC/RW	2900325	419	PLC-RSC-120UC/21-21/EX	2909511	458
PLC-BSC-230UC/21HC/SO46	2980445	389	PLC-OSC-60DC/ 24DC/ 2	2967468	377	PLC-RPT-110UC/21-21/RW	2900348	419	PLC-RSC-120UC/21-21AU	2967138	375
PLC-BSC-TTL/1	2982689	412	PLC-OSC-60DC/ 48DC/100	2967455	376	PLC-RPT-110UC/21-21AU/RW	2900351	419	PLC-RSC-120UC/21/EX	2909525	458
PLC-ESK GY	2966508	424	PLC-OSC-60DC/230AC/ 1	2967866	377	PLC-RPT-110UC/21/RW	2900320	418	PLC-RSC-120UC/21/MS	2909651	373
PLC-HPT-24DC/230AC/10	2905215	409	PLC-OSC-60DC/300DC/ 1	2980681	406	PLC-RPT-110UC/21AU/RW	2900323	418	PLC-RSC-120UC/21AU	2966281	373
PLC-HSC-24DC/230AC/10	2905214	409	PLC-OSC-110DC/300DC/ 1	2980694	406	PLC-RPT-110UC/21HC/RW	2900326	419	PLC-RSC-120UC/21AU/MS	2909657	373
PLC-LOGIC-STARTERKIT3	2909916	432	PLC-OSC-120AC/300DC/ 1	2980717	406	PLC-RPT-120UC/ 1AU/MS/SEN	2909679	385	PLC-RSC-120UC/21HC	2967662	387
PLC-OPT-5DC/ 24DC/100KHZ	2902969	410	PLC-OSC-120UC/ 24DC/ 2	2966650	377	PLC-RPT-120UC/ 1AU/SEN	2900314	384	PLC-RSC-120UC/21HC/EX	2909520	459
PLC-OPT-5DC/ 24DC/2/ACT	2900375	380	PLC-OSC-120UC/ 24DC/ 2/C1D2	5603262	459	PLC-RPT-120UC/21	2900304	372	PLC-RSC-12DC/21-21/EX	2909517	458
PLC-OPT-5DC/ 5DC/100KHZ-G	29002971	411	PLC-OSC-120UC/ 48DC/ 100	2966744	376	PLC-RPT-120UC/21-21	2900335	374	PLC-RSC-12DC/21/EX	2909522	458
PLC-OPT-5DC/24DC/100KHZ-G	2902973	411	PLC-OSC-120UC/ 48DC/100/C1D2	5603263	459	PLC-RPT-120UC/21-21/EX	2909515	458	PLC-RSC-12DC/21HC/EX	2909518	459
PLC-OPT-5DC/300DC/1	2900381	406	PLC-OSC-120UC/ 48DC/100/SEN	2966799	385	PLC-RPT-120UC/21-21AU	2900342	375	PLC-RSC-230UC/ 1AU/MS/SEN	2909665	385
PLC-OPT-12DC/300DC/1	2900382	406	PLC-OSC-120UC/230AC/ 1	2967879	377	PLC-RPT-120UC/21/EX	2909529	458	PLC-RSC-230UC/ 1AU/SEN	2966333	384
PLC-OPT-24DC/ 24DC/10/R	2900398	417	PLC-OSC-125DC/ 24DC/ 2	2980650	377	PLC-RPT-120UC/21/MS	2909669	373	PLC-RSC-230UC/21	2966207	372
PLC-OPT-24DC/ 24DC/2	2900364	377	PLC-OSC-125DC/ 48DC/100	2980047	376	PLC-RPT-120UC/21AU	2900310	373	PLC-RSC-230UC/21-21	2967099	374
PLC-OPT-24DC/ 24DC/2/ACT	2900376	380	PLC-OSC-125DC/230AC/ 1	2980063	377	PLC-RPT-120UC/21AU/MS	2909674	373	PLC-RSC-230UC/21-21/EX	2909512	458
PLC-OPT-24DC/ 24DC/3/RW	2900379	415	PLC-OSC-220DC/300DC/ 1	2980704	406	PLC-RPT-120UC/21HC	2900296	387	PLC-RSC-230UC/21-21AU	2967141	375
PLC-OPT-24DC/ 48DC/100	2900352	376	PLC-OSC-230AC/300DC/ 1	2980720	406	PLC-RPT-120UC/21HC/EX	2909533	459	PLC-RSC-230UC/21/EX	2909526	458
PLC-OPT-24DC/ 48DC/100/SEN	2900358	385	PLC-OSC-230UC/ 24DC/ 2	2966663	377	PLC-RPT-12DC/21-21/EX	2909513	458	PLC-RSC-230UC/21/MS	2909653	373
PLC-OPT-24DC/ 48DC/500W	2900378	407	PLC-OSC-230UC/ 48DC/100	2966757	376	PLC-RPT-12DC/21/EX	2909527	458	PLC-RSC-230UC/21AU	2966294	373
PLC-OPT-24DC/ 5DC/100KHZ-G	2902972	411	PLC-OSC-230UC/ 48DC/100/SEN	2966809	385	PLC-RPT-12DC/21HC/EX	2909531	459	PLC-RSC-230UC/21AU/MS	2909660	373
PLC-OPT-24DC/110DC/3/RW	2900391	415	PLC-OSC-230UC/230AC/ 1	2967882	377	PLC-RPT-230UC/ 1AU/MS/SEN	2909680	385	PLC-RSC-230UC/21HC	2967675	387
PLC-OPT-24DC/230AC/1	2900369	377	PLC-OSC-LPE-24DC/48DC/100	2903171	422	PLC-RPT-230UC/ 1AU/SEN	2900315	384	PLC-RSC-230UC/21HC/EX	2909521	459
PLC-OPT-24DC/230AC/2.4/ACT	2904632	408	PLC-OSP-24DC/ 24DC/ 3/RW	2980513	415	PLC-RPT-230UC/21AU/MS	2900305	372	PLC-RSC-24DC/21/EX	2909524	458
PLC-OPT-24DC/24DC/100KHZ	2902970	410	PLC-OSP-24DC/110DC/ 3/RW	2982511	415	PLC-RPT-230UC/21-21	2900336	374	PLC-RSC-24DC/21HC/EX	2909519	459
PLC-OPT-24DC/24DC/100KHZ-G	2902974	411	PLC-OSP-36DC/110DC/ 3/RW	2982524	415	PLC-RPT-230UC/21-21/EX	2909516	458	PLC-SC-EIK 1-SVN 24P/P	2982663	420
PLC-OPT-24DC/300DC/1	2900363	406	PLC-OSP-48DC/110DC/ 3/RW	2982537	415	PLC-RPT-230UC/21-21AU	2900343	375	PLC-SC-ELR W1/ 2-24DC	2980539	421
PLC-OPT-24DC/TTL	2900363	414	PLC-OSP-72DC/110DC/ 3/RW	2982540	415	PLC-RPT-230UC/21-21AU/RWF	2900345	417	PLC-SC-SH	2980733	405
PLC-OPT-36DC/110DC/3/RW	2900392	415	PLC-OSP-96DC/110DC/ 3/RW	2982553	415	PLC-RPT-230UC/21/EX	2909530	458	PLC-SC-SL	2980775	405
PLC-OPT-48DC/ 24DC/2	2900365	377	PLC-OSP-110DC/ 24DC/ 3/RW	2980526	415	PLC-RPT-230UC/21/MS	2909670	373	PLC-SP-ELR W1/ 2-24DC	2980555	421
PLC-OPT-48DC/ 48DC/100	2900353	376	PLC-OSP-110DC/110DC/ 3/RW	2982566	415	PLC-RPT-230UC/21AU	2900311	373	PLC-V8/D15B/IN	2926087	425
PLC-OPT-48DC/110DC/3/RW	2900393	415	PLC-PT-EIK 1-SVN 24P/P	2900397	420	PLC-RPT-230UC/21AU/MS	2909676	373	PLC-V8/D15B/OUT	2966061	425
PLC-OPT-48DC/230AC/1	2900370	377	PLC-RPT-12DC/21	2900316	372	PLC-RPT-230UC/21HC	2900297	387	PLC-V8/D15S/IN	2296074	425
PLC-OPT-60DC/ 24DC/2	2900366	377	PLC-RPT-12DC/21-21	2900329	374	PLC-RPT-230UC/21HC/EX	2909534	459	PLC-V8/D15S/OUT	2296058	425
PLC-OPT-60DC/ 48DC/100	2900354	376	PLC-RPT-12DC/21-21AU	2900337	375	PLC-RPT-24DC/21/EX	2909528	458	PLC-V8/FLK14/IN	2296533	425
PLC-OPT-60DC/230AC/1	2900371	377	PLC-RPT-12DC/21/MS	2909666	373	PLC-RPT-24DC/21HC/EX	2909532	459	PLC-V8/FLK14/IN/M	2304115	425
PLC-OPT-60DC/300DC/1	2900384	406	PLC-RPT-12DC/21AU	2900317	373	PLC-RSC-12DC/21	2966906	372	PLC-V8/FLK14/OUT	2295554	425
PLC-OPT-72DC/110DC/3/RW	2900394	415	PLC-RPT-12DC/21AU/MS	2909671	373	PLC-RSC-12DC/21-21	2967235	374	PLC-V8/FLK14/OUT/M	2304102	425
PLC-OPT-96DC/110DC/3/RW	2900395	415	PLC-RPT-12DC/21HC	2967277	375	PLC-RSC-12DC/21-21AU	2967277	375	PLC-V8/CAB/TBUS/0,3M	2905263	433
PLC-OPT-110DC/ 24DC/3/RW	2900380	415	PLC-RPT-24DC/ 1/ACT	2900312	378	PLC-RSC-12DC/21/MS	2909648	373	PLC-V8C/PT-24DC/BM2	2907446	429
PLC-OPT-110DC/110DC/3/RW	2900396	415	PLC-RPT-24DC/ 1/MS/ACT	2909677	379	PLC-RSC-12DC/21AU	2966919	373	PLC-V8C/PT-24DC/EM	2905137	429
PLC-OPT-110DC/300DC/1	2900385	406	PLC-RPT-24DC/ 1AU/MS/SEN	2909678	385	PLC-RSC-12DC/21AU/MS	2909654	373	PLC-V8C/PT-24DC/SAM2	2907443	428
PLC-OPT-120AC/300DC/1	2900388	406	PLC-RPT-24DC/ 1AU/SEN	2900313	384	PLC-RSC-12DC/21HC	2967617	387	PLC-V8C/SC-24DC/BM2	2907447	429
PLC-OPT-120UC/ 24DC/2	2900367	377	PLC-RPT-24DC/ 1C/ACT	2900298	386	PLC-RSC-24DC/ 1- 1/ACT	2967109	379	PLC-V8C/SC-24DC/EM	2903095	429
PLC-OPT-120UC/ 48DC/ 100	2900355	376	PLC-RPT-24DC/21	2900299	372	PLC-RSC-24DC/ 1/ACT	2966210	378	PLC-V8C/SC-24DC/SAM2	2907445	428
PLC-OPT-120UC/ 48DC/100/SEN	2900359	385	PLC-RPT-24DC/21-21	2900330	374	PLC-RSC-24DC/ 1/MS/ACT	2909661	379	PLC-V8/FLK14/OUT	2299660	425
PLC-OPT-120UC/230AC/1	2900372	377	PLC-RPT-24DC/21-21/EX	2909514	458	PLC-RSC-24DC/ 1AU/MS/SEN	2909663	385	PLC-V8/FLK14/OUT/M	2304306	425
PLC-OPT-220DC/300DC/1	2900387	406	PLC-RPT-24DC/21-21AU	2900338	375	PLC-RSC-24DC/ 1AU/SEN	2966317	384	PLC-VT	2296870	546
PLC-OPT-230AC/300DC/1	2900389	406	PLC-RPT-24DC/21/MS	2909667	373	PLC-RSC-24DC/ 1C/ACT	2967604	386	PLC-VT/ACT	2295567	546
PLC-OPT-230UC/ 24DC/2	2900368	377	PLC-RPT-24DC/21AU	2900306	373	PLC-RSC-24DC/21	2966171	372	PLC-VT/ACT/LA	2296867	546
PLC-OPT-230UC/ 48DC/100	2900356	376	PLC-RPT-24DC/21AU/MS	2909672	373	PLC-RSC-24DC/21-21	2967060	374	PLC-VT/LA	2296854	546
PLC-OPT-230UC/ 48DC/100/SEN	2900361	385	PLC-RPT-24DC/21HC	2900291	387	PLC-RSC-24DC/21-21/EX	2909509	458	PSK AFS2000IOL	2700709	217
PLC-OPT-230UC/230AC/1	2900374	377	PLC-RPT-24UC/ 1/S/H	2900328	404	PLC-RSC-24DC/21-21AU	2967125	375	PSK AFS5000IOL	2700705	217
PLC-OPT-LPE-24DC/48DC/100	2903173	422	PLC-RPT-24UC/ 1/S/L	2900327	404	PLC-RSC-24DC/21/MS	2909649	373	PSK AFS6000IOL	2700707	216
PLC-OSC-5DC/ 5DC/100KHZ-G	2902965	411	PLC-RPT-24UC/21	2900300	372	PLC-RSC-24DC/21AU	2966265	373	PSK AFS6050IOL	2700704	216
PLC-OSC-5DC/ 24DC/ 2/ACT	2980144	380	PLC-RPT-24UC/21-21	2900332	374	PLC-RSC-24DC/21AU/MS	2909655	373	PSK AFS8000IOL	2700708	217
PLC-OSC-5DC/ 24DC/100KHZ	2902963	410	PLC-RPT-24UC/21-21/RW	2900346	419	PLC-RSC-24DC/21HC	2967620	387	PSK AFS7004IOL	2700710	218
PLC-OSC-5DC/ 24DC/100KHZ-G	2902967	411	PLC-RPT-24UC/21-21AU	2900339	375	PLC-RSC-24UC/ 1/S/H	2982236	404	PSK RTU 50	2700018	215
PLC-OSC-5DC/300DC/ 1	2980652	406	PLC-RPT-24UC/21-21AU/RW	2900349	419	PLC-RSC-24UC/ 1/S/L	2834876	404	PSM-KAD 9 SUB 25/BS	2761295	251
PLC-OSC-12DC/300DC/ 1	2980665	406	PLC-RPT-24UC/21/MS	2909668	373	PLC-RSC-24UC/21	2966184	372	PSM-ME-RS232/RS485-P	2744416	166
PLC-OSC-24DC/ 5DC/100KHZ-G	2902966	411	PLC-RPT-24UC/								

Index

Alphabetical

Type	Order No.	Page	Type	Order No.	Page	Type	Order No.	Page	Type	Order No.	Page
REL-IR2/L-120AC/2X21	2903667	314	REL-MR-230AC/21-21AU/MS	2987998	306	RIF-1-RPT-LDP-24DC/2X21AU	2903330	341	RIF-3-RSC-LV-230AC/3X21	2903298	357
REL-IR2/L-230AC/2X21	2903668	314	REL-MR-230AC/21HC	2961422	304	RIF-1-RPT-LDP-24DC/2X21MS	2905291	345	RIF-4-BPT/3X21	2900961	324
REL-IR2/LDP-12DC/2X21	2903669	314	REL-MR-230AC/21HC AU	2961529	304	RIF-1-RPT-LV-120AC/1X21	2903340	340	RIF-4-BSC/3X21	2900960	325
REL-IR2/LDP-24DC/2X21	2903660	314	REL-MR-230AC/21HC AU/MS	2987930	306	RIF-1-RPT-LV-120AC/1X21AU	2903336	340	RIF-4-RPT-LDP-24DC/2X21	2903281	358
REL-IR2/LDP-110DC/2X21	2903663	314	REL-MR-230AC/21HC/MS	2987914	306	RIF-1-RPT-LV-120AC/1X21MS	2909776	344	RIF-4-RPT-LDP-24DC/3X1	2903275	360
REL-IR2/LDP-125DC/2X21	2903664	314	REL-MR-BL-100AC/21-21/MS	2908183	308	RIF-1-RPT-LV-120AC/2X21	2903332	341	RIF-4-RPT-LDP-24DC/3X21	2903278	359
REL-IR2/LDP-220DC/2X21	2903665	314	REL-MR-BL-100AC/21HC/MS	2908179	308	RIF-1-RPT-LV-120AC/2X21AU	2903328	341	RIF-4-RPT-LV-120AC/2X21	2903280	358
REL-IR4/100AC/4X21	2907055	316	REL-MR-BL-200AC/21-21/MS	2908182	308	RIF-1-RPT-LV-120AC/2X21MS	2909775	345	RIF-4-RPT-LV-120AC/3X1	2903274	360
REL-IR4/200AC/4X21	2907056	316	REL-MR-BL-200AC/21HC/MS	2908178	308	RIF-1-RPT-LV-230AC/1X21	2903339	340	RIF-4-RPT-LV-120AC/3X21	2903277	359
REL-IR4/24DC/4X21	2907054	316	REL-MR-BL-24DC/21-21/MS	2908181	308	RIF-1-RPT-LV-230AC/1X21AU	2903335	340	RIF-4-RPT-LV-230AC/2X21	2903279	358
REL-IR4/L-24AC/4X21	2903686	314	REL-MR-BL-24DC/21HC/MS	2908180	308	RIF-1-RPT-LV-230AC/1X21MS	2905290	344	RIF-4-RPT-LV-230AC/3X1	2903273	360
REL-IR4/L-24AC/4X21AU	2903683	314	REL-MR-G 24/1	2961037	536	RIF-1-RPT-LV-230AC/2X21	2903331	341	RIF-4-RPT-LV-230AC/3X21	2903276	359
REL-IR4/L-120AC/4X21	2903687	314	REL-OR2/L-24AC/2X21	2903690	322	RIF-1-RPT-LV-230AC/2X21AU	2903327	341	RIF-4-RSC-LDP-24DC/2X21	2903291	362
REL-IR4/L-120AC/4X21AU	2903684	314	REL-OR2/L-120AC/2X21	2903691	322	RIF-1-RPT-LV-230AC/2X21MS	2905292	345	RIF-4-RSC-LDP-24DC/3X1	2903284	364
REL-IR4/L-230AC/4X21	2903688	314	REL-OR2/L-230AC/2X21	2903692	322	RIF-1-RPT-LV-24AC/1X21	2903341	340	RIF-4-RSC-LDP-24DC/3X21	2903288	363
REL-IR4/L-230AC/4X21AU	2903685	314	REL-OR2/LDP-24DC/2X21	2903689	322	RIF-1-RPT-LV-24AC/1X21AU	2903337	340	RIF-4-RSC-LV-120AC/2X21	2903290	362
REL-IR4/LDP-12DC/4X21	2903676	314	REL-OR2/LDP-220DC/2X21	2907026	322	RIF-1-RPT-LV-24AC/2X21	2903333	341	RIF-4-RSC-LV-120AC/3X1	2903283	364
REL-IR4/LDP-110DC/4X21AU	2903673	314	REL-OR3/L-24AC/3X21	2903694	322	RIF-1-RPT-LV-240C/2X21AU	2903329	341	RIF-4-RSC-LV-120AC/3X21	2903287	363
REL-IR4/LDP-24DC/4X21	2903677	314	REL-OR3/L-120AC/3X21	2903695	322	RIF-1-RSC-LDP-12DC/1X21	2908500	342	RIF-4-RSC-LV-230AC/2X21	2903289	362
REL-IR4/LDP-24DC/4X21AU	2903670	314	REL-OR3/L-230AC/3X21	2903696	322	RIF-1-RSC-LDP-12DC/2X21	2908501	343	RIF-4-RSC-LV-230AC/3X1	2903282	364
REL-IR4/LDP-110DC/4X21	2903680	314	REL-OR3/LDP-110DC/3X21	2908898	322	RIF-1-RSC-LDP-24DC/11C	2909885	348	RIF-4-RSC-LV-230AC/3X21	2903285	363
REL-IR4/LDP-110DC/4X21AU	2903673	314	REL-OR3/LDP-220DC/3X21	2907027	322	RIF-BR-12-230 AC	2903358	342	RIF-BR-12-230 AC	2907060	330
REL-IR4/LDP-125DC/4X21	2903681	314	REL-OR3/LDP-24DC/3X21	2903693	322	RIF-1-RSC-LDP-24DC/1X21AU	2903354	342	RIF-LDM-12-24 DC	2907057	330
REL-IR4/LDP-125DC/4X21AU	2903674	314	REL-OR3/LDP-48DC/3X21	2908897	322	RIF-1-RSC-LDP-24DC/1X21MS	2905659	346	RIF-LDP-110 DC	2900941	330
REL-IR4/LDP-220DC/4X21	2903682	314	REL-PR1-110DC/1/MB	2908044	328	RIF-1-RSC-LDP-24DC/2X21	2903350	343	RIF-LDP-12-24 DC	2900939	330
REL-IR4/LDP-220DC/4X21AU	2903675	314	REL-PR1-220DC/1/MB	2908046	328	RIF-1-RSC-LDP-240C/2X21AU	2903346	343	RIF-LDP-48-60 DC	2900940	330
REL-MR 4.5DC/21AU	2961370	392	REL-PR1-230AC/1/MB	2908047	328	RIF-1-RSC-LDP-24DC/2X21MS	2905660	347	RIF-LV-12-24 UC	2900942	330
REL-MR-4.5DC/21	2961367	392	REL-PR1-24DC/1/MB	2908040	328	RIF-1-RSC-LV-120AC/1X21	2903356	342	RIF-LV-120-230 AC/110 DC	2900944	330
REL-MR-12DC/21	2961150	298	REL-PR2-24AC/2X21	2903699	326	RIF-1-RSC-LV-120AC/1X21AU	2903352	342	RIF-LV-48-60 UC	2900943	330
REL-MR-12DC/21-21	2961257	304	REL-PR2-24DC/2X21	2903698	326	RIF-1-RSC-LV-120AC/1X21MS	2909774	346	RIF-LVM-100-200 AC/110 DC	2907058	330
REL-MR-12DC/21-21AU	2961299	304	REL-PR2-120AC/2X21	2903700	326	RIF-1-RSC-LV-120AC/2X21	2903348	343	RIF-RC-12-24 UC	2900949	330
REL-MR-12DC/21/MS	2909641	298	REL-PR2-230AC/2X21	2903701	326	RIF-1-RSC-LV-120AC/2X21AU	2903344	343	RIF-RC-120-230 UC	2900951	330
REL-MR-12DC/21AU	2961163	298	REL-PR3-24AC/3X1	2903707	328	RIF-1-RSC-LV-120AC/2X21MS	2909773	347	RIF-RC-48-60 UC	2900950	330
REL-MR-12DC/21AU/MS	2909644	298	REL-PR3-24AC/3X21	2903703	326	RIF-1-RSC-LV-230AC/1X21	2903355	342	RIF-RH-1	2900953	303
REL-MR-12DC/21HC	2961309	304	REL-PR3-24DC/3X1	2903706	328	RIF-1-RSC-LV-230AC/1X21AU	2903551	342	RIF-RH-1-H	2904468	303
REL-MR-12DC/21HC AU	2961532	304	REL-PR3-24DC/3X21	2903702	326	RIF-1-RSC-LV-230AC/1X21MS	2905661	346	RIF-RH-2	2900954	313
REL-MR-18DC/21	2961383	392	REL-PR3-110DC/3X21	2908893	326	RIF-1-RSC-LV-230AC/2X21	2903347	343	RIF-RH-3	2900955	319
REL-MR-18DC/21AU	2961493	392	REL-PR3-120AC/3X1	2903708	328	RIF-1-RSC-LV-230AC/2X21AU	2903343	343	RIF-RH-4	2900956	325
REL-MR-24AC/21-21	2961435	304	REL-PR3-120AC/3X21	2903704	326	RIF-1-RSC-LV-230AC/2X21MS	2905662	347	RIF-RHM-1	2905986	303
REL-MR-24AC/21-21/MS	2987956	306	REL-PR3-230AC/3X1	2903709	328	RIF-1-RSC-LV-24AC/1X21	2903357	342	RIF-RHM-1-H	2905985	303
REL-MR-24AC/21-21AU	2961464	304	REL-PR3-230AC/3X21	2903705	326	RIF-1-RSC-LV-24AC/1X21AU	2903353	342	RIF-RHM-2	2905984	313
REL-MR-24AC/21HC	2961406	304	REL-SR-24DC/2X21/FG	2908777	457	RIF-1-RSC-LV-24AC/2X21	2903349	343	RIF-RHM-4	2905983	325
REL-MR-24AC/21HC AU	2961503	304	RIF-0-BPT-M/ 21	2908448	296	RIF-1-RSC-LV-24AC/2X21AU	2903345	343	RIF-RHS-2	2908043	313
REL-MR-24AC/21HC/MS	2987891	306	RIF-0-BPT/1	2901873	297	RIF-1-V8/PT/FLK14/OUT	2905195	367	RIF-T3-24UC	2902647	274
REL-MR-24DC/11C	2961341	393	RIF-0-BPT/21	2900958	296	RIF-1-V8/PT/FLK14/OUT/M	2906992	547	RIF-V-12-24 UC	2900945	330
REL-MR-24DC/21	2961105	298	RIF-0-BSC/ 1	2901872	297	RIF-2-BPT/4X21	2900934	312	RIF-V-120-230 UC	2900948	330
REL-MR-24DC/21-21	2961192	304	RIF-0-BSC/21	2900957	297	RIF-2-BSC/4X21	2900932	313	RIF-V-48-60 UC	2900947	330
REL-MR-24DC/21-21/MS	2987943	306	RIF-0-OPT-24DC/230AC/1	2905295	337	RIF-2-RPT-LDP-24DC/2X21	2903315	350			
REL-MR-24DC/21-21AU	2961215	304	RIF-0-OPT-24DC/24DC/2	2905293	336	RIF-2-RPT-LDP-24DC/4X21	2903308	351			
REL-MR-24DC/21-21AU/MS	2987985	306	RIF-0-OPT-24DC/48DC/100	2905294	337	RIF-2-RPT-LV-120AC/2X21	2903311	350			
REL-MR-24DC/21/MS	2909642	298	RIF-0-OSC-24DC/230AC/1	2905656	339	RIF-2-RPT-LV-120AC/4X21	2903305	351			
REL-MR-24DC/21AU	2961121	298	RIF-0-OSC-24DC/24DC/2	2905657	338	RIF-2-RPT-LV-230AC/2X21	2903310	350			
REL-MR-24DC/21AU/MS	2909645	298	RIF-0-OSC-24DC/48DC/100	2905658	339	RIF-2-RPT-LV-230AC/4X21	2903304	351	SCK-C-MODBUS	2901674	258
REL-MR-24DC/21HC	2961312	304	RIF-0-RPT-12DC/ 1	2903362	333	RIF-2-RPT-LV-24AC/2X21	2903313	350	SCK-M-I-4S-20A	2903242	259
REL-MR-24DC/21HC AU	2961545	304	RIF-0-RPT-12DC/ 1AU	2903360	333	RIF-2-RPT-LV-24AC/4X21	2903306	351	SCK-M-I-8S-20A	2903241	259
REL-MR-24DC/21HC AU/MS	2987927	306	RIF-0-RPT-12DC/21	2903371	332	RIF-2-RSC-LDP-125DC/2X21	2903324	352	SCK-M-U-1500V	2903591	259
REL-MR-24DC/21HC/MS	2987888	306	RIF-0-RPT-12DC/21AU	2903369	332	RIF-2-RSC-LDP-125DC/4X21	2903319	353			
REL-MR-48DC/21-21	2834834	304	RIF-0-RPT-24DC/ 1	2903361	333	RIF-2-RSC-LDP-24DC/2X21	2903326	352			
REL-MR-48DC/21-21AU	2834847	304	RIF-0-RPT-24DC/ 1AU	2903359	333	RIF-2-RSC-LDP-24DC/4X21	2903320	353			
REL-MR-48DC/21HC	2834821	304	RIF-0-RPT-24DC/21	2903370	332	RIF-2-RSC-LV-120AC/2X21	2903322	352	SD FLASH 2GB EMLOG	2403484	214
REL-MR-60DC/21	2961118	392	RIF-0-RPT-24DC/21AU	2903368	332	RIF-2-RSC-LV-120AC/4X21	2903317	353	SK 5,0 WH:REEL	0805221	102
REL-MR-60DC/21-21	2961273	304	RIF-0-RPT-M-24DC/21	2908327	332	RIF-2-RSC-LV-230AC/2X21	2903321	352	SSA 3-6	2839295	175
REL-MR-60DC/21-21AU	2961286	304	RIF-0-RSC-12DC/ 1	2903367	335	RIF-2-RSC-LV-230AC/4X21	2903316	353	SSA 5-10	2839512	172
REL-MR-60DC/21/MS	2909643	392	RIF-0-RSC-12DC/ 1AU	2903365	335	RIF-2-RSC-LV-24AC/2X21	2903323	352	ST-OV3-24DC/400AC/3	2905417	448
REL-MR-60DC/21AU	2961134	392	RIF-0-RSC-12DC/21	2903375	334	RIF-2-RSC-LV-24AC/4X21	2903318	353	ST-OV4-24DC/ 24DC/1-PRO	2905572	449
REL-MR-60DC/21AU/MS	2909647	392	RIF-0-RSC-12DC/21AU	2903373	334	RIF-3-BPT/2X21	2900937	318	ST-OV4-24DC/ 24DC/4-PRO	2905585	449
REL-MR-60DC/21HC	2961325	304	RIF-0-RSC-24DC/ 1	2903366	335	RIF-3-BPT/3X21	2900938	319	ST-REL3-KG 24/ 1/SO38	2829564	446
REL-MR-110DC/21-21	2961202	304	RIF-0-RSC-24DC/ 1AU	2903364	335	RIF-3-BSC/2X21	2900935	320	ST-REL3-KG 24/21/AU/SO46	2826981	444
REL-MR-110DC/21-21AU	2961228	304	RIF-0-RSC-24DC/21	2903374	334	RIF-3-BSC/3X21	2900936	321	ST-REL3-KG 24/21/SO46	2826091	444
REL-MR-110DC/21HC	2961338	304	RIF-0-RSC-24DC/21AU	2903372	334	RIF-3-RPT-LDP-24DC/2X21	2903297	354	ST-REL3-KG 120/21/AU/SO46	2829797	444
REL-MR-110DC/21HC AU	2961561	304	RIF-1-BPT/2X21	2900931	302	RIF-3-RPT-LDP-24DC/3X21	2903294	355	ST-REL3-KG 120/21/SO46	2833026	444

Type	Order No.	Page	Type	Order No.	Page	Type	Order No.	Page	Type	Order No.	Page
SWD4-CRP-2 PXC	2903114	38	UMK- EC38/38-XOL	2976284	578	VIP-2/SC/D37SUB/M/SO	2900786	487	VIP-3/SC/D50SUB/M	2315159	571
SWD4-RC8-10 PXC	2903106	38	UMK- EC38/38-XOR	2976297	578	VIP-2/SC/FLK10	2315010	566	VIP-3/SC/D50SUB/M/LED	2322184	571
SZF 1-0,6X3,5	1204517	424	UMK- EC56/25/EX -FRONT 2,5V/L	2901115	581	VIP-2/SC/FLK10/LED	2322045	567	VIP-3/SC/FLK14/8IM/LED/PLC	2322265	531
			UMK- EC56/25/EX -FRONT 2,5V/R	2900114	581	VIP-2/SC/FLK14	2315023	566	VIP-3/SC/FLK14/8IM/PLC	2322278	531
			UMK- EC56/25/EX -L	2900113	581	VIP-2/SC/FLK14/8M/PLC	2322281	528	VIP-3/SC/FLK26	2315052	567
			UMK- EC56/25/EX -R	2900112	581	VIP-2/SC/FLK14/8P/PLC	2322294	528	VIP-3/SC/FLK26/LED	2322087	567
			UMK- EC56/32-XOL	2975764	579	VIP-2/SC/FLK14/LED	2322058	567	VIP-3/SC/FLK34	2315065	567
			UMK- EC56/32-XOR	2975858	579	VIP-2/SC/FLK14/LED/PLC	2322249	526	VIP-3/SC/FLK34/LED	2322090	567
			UMK- EC56/32-XUL	2975780	579	VIP-2/SC/FLK14/PLC	2315214	526	VIP-3/SC/FLK40	2315078	567
			UMK- EC56/32-XUR	2975777	579	VIP-2/SC/FLK16	2315036	566	VIP-3/SC/FLK40/LED	2322100	567
			UMK- EC56/56-XOL	2975890	579	VIP-2/SC/FLK16/LED	2322061	567	VIP-3/SC/FLK50	2315081	567
			UMK- EC56/56-XOR	2975900	579	VIP-2/SC/FLK20	2315049	566	VIP-3/SC/FLK50/AN/2P/S7-1500	2908497	512
			UMK- EC56/Front 2,5V/L	2976158	579	VIP-2/SC/FLK20/LED	2322074	567	VIP-3/SC/FLK50/AN/S7-1500	2908495	512
			UMK- EC56/Front 2,5V/R	2976161	579	VIP-3/PT/2FLK11(1-40)/S7	2315243	508	VIP-3/SC/FLK50/LED	2322113	567
			UMK- EC90/32/EX-XOL	2900110	580	VIP-2/SC/FLK50/16/SLC500	2322320	477	VIP-3/SC/FLK60	2315094	567
			UMK- EC90/32/EX-XOR	2900109	580	VIP-2/SC/FLK50/AB-1756	2322317	474	VIP-3/SC/FLK60/LED	2322126	567
			UMK- EC90/32/EX-XUL	2969071	580	VIP-2/SC/FLK50/LED/PLC	2322252	527	VIP-3/SC/FLK64	2315104	567
			UMK- EC90/32/EX-XUR	2969068	580	VIP-2/SC/FLK50/MODI-TSX/Q	2322304	474	VIP-3/SC/FLK64/LED	2322139	567
			UMK- PVB	2971302	599	VIP-2/SC/FLK50/PLC	2315227	527	VIP-3/SC/HD26SUB/F	2322414	576
			UMK- PVB 6	2972136	599	VIP-2/SC/FLK50/S7/A-S400	2322359	508	VIP-3/SC/HD26SUB/M	2322375	576
			UMK-16 RELS/KSR-G24/21/E/PLC	2974891	539	VIP-2/SC/HD15SUB/F	2322401	576	VIP-3/SC/HD44SUB/F	2322427	576
			UMK-16 RELS/KSR-G24/21/PLC	2974901	539	VIP-2/SC/PDM-2/16	2315256	598	VIP-3/SC/HD44SUB/M	2322388	576
			UMK-16 RM/KSR-G 24/21/E/PLC	2979508	539	VIP-2/SC/PDM-2/24	2315269	598	VIP-3/SC/HD62SUB/F	2322430	576
			UMK-16 RM/KSR-G 24/21/PLC	2979498	539	VIP-2/SC/PDM-2/32	2315272	598	VIP-3/SC/HD62SUB/M	2322391	576
			UMK-32 RM/MR-G24/1/PLC	2979472	536	VIP-2/SC/PDM-2/48	2903717	598	VIP-3/SC/RJ45	2900701	577
			URELG 3	2820136	444	VIP-3/PT/2FLK14/AN/2P/S7-1500A	2908465	513	VIP-8RPT-120AC/1AU/DI/PLC	2904576	543
			UT 4-MTD-R/CVC 690/SET	2901667	14	VIP-3/PT/2FLK14/AN/2P/S7-1500B	2908846	513	VIP-8RPT-24DC/1AU/DI/PLC	2903600	543
						VIP-3/PT/D25SUB/F	2903782	573	VIP-8RPT-24DC/21/DO/FU/PLC	2903601	542
						VIP-3/PT/D25SUB/F/LED	2904265	573	VIP-CAB-FLK10-0,14/...	2318376	582
						VIP-3/PT/D25SUB/M	2903781	573	VIP-CAB-FLK10/0,14/1,0M	2318318	582
						VIP-3/PT/D25SUB/M/LED	2904260	573	VIP-CAB-FLK10/0,14/2,0M	2318334	582
						VIP-3/PT/D37SUB/F	2903784	573	VIP-CAB-FLK10/0,14/3,0M	2318347	582
						VIP-3/PT/D37SUB/F/LED	2904266	573	VIP-CAB-FLK10-0,14/...	2318457	582
						VIP-3/PT/D37SUB/M	2903783	573	VIP-CAB-FLK14/0,14/1,0M	2318392	582
						VIP-3/PT/D37SUB/M/HW/C300	2904276	577	VIP-CAB-FLK14/0,14/2,0M	2318415	582
						VIP-3/PT/D37SUB/M/LED	2904261	573	VIP-CAB-FLK14/0,14/3,0M	2318428	582
						VIP-3/PT/D50SUB/F	2903786	573	VIP-CAB-FLK14/AXIO/0,14/0,5M	2901604	491
						VIP-3/PT/D50SUB/F/LED	2904267	573	VIP-CAB-FLK14/AXIO/0,14/1,0M	2901605	491
						VIP-3/PT/D50SUB/M	2903785	573	VIP-CAB-FLK14/AXIO/0,14/1,5M	2901606	491
						VIP-3/PT/D50SUB/M/LED	2904262	573	VIP-CAB-FLK14/AXIO/0,14/2,0M	2901607	491
						VIP-3/PT/FLK14/8IM/LED/PLC	2904281	531	VIP-CAB-FLK14/AXIO/0,14/2,5M	2901608	491
						VIP-3/PT/FLK14/8IM/PLC	2904282	531	VIP-CAB-FLK14/AXIO/0,14/3,0M	2901609	491
						VIP-3/PT/FLK26	2903791	569	VIP-CAB-FLK14/AXIO/0,14/4,0M	2901610	491
						VIP-3/PT/FLK26/LED	2904252	569	VIP-CAB-FLK14/AXIO/0,14/6,0M	2901611	491
						VIP-3/PT/FLK34	2903792	569	VIP-CAB-FLK14/FR/OE/0,14/0,5M	2900122	584
						VIP-3/PT/FLK34/LED	2904253	569	VIP-CAB-FLK14/FR/OE/0,14/1,0M	2900123	584
						VIP-3/PT/FLK34/FR/OE/0,14/1,5M	2903793	569	VIP-CAB-FLK14/FR/OE/0,14/1,5M	2900125	584
						VIP-3/PT/FLK40/LED	2904254	569	VIP-CAB-FLK14/FR/OE/0,14/2,0M	2900126	584
						VIP-3/PT/FLK50	2903794	569	VIP-CAB-FLK14/FR/OE/0,14/3,0M	2900127	584
						VIP-3/PT/FLK50/AN/2P/S7-1500	2908499	512	VIP-CAB-FLK16/FR/OE/0,14/0,5M	2900130	584
						VIP-3/PT/FLK50/AN/S7-1500	2908496	512	VIP-CAB-FLK16/FR/OE/0,14/1,0M	2900131	584
						VIP-3/PT/FLK50/LED	2904255	569	VIP-CAB-FLK16/FR/OE/0,14/1,5M	2900132	584
						VIP-3/PT/FLK60	2903795	569	VIP-CAB-FLK16/FR/OE/0,14/2,0M	2900133	584
						VIP-3/PT/FLK60/LED	2904256	569	VIP-CAB-FLK16/FR/OE/0,14/3,0M	2900134	584
						VIP-3/PT/FLK64	2903796	569	VIP-CAB-FLK20/FR/OE/0,14/1,0M	2900139	585
						VIP-3/PT/FLK64/LED	2904257	569	VIP-CAB-FLK20/FR/OE/0,14/2,0M	2900142	585
						VIP-3/PT/HD26SUB/F	2904273	576	VIP-CAB-FLK20/FR/OE/0,14/3,0M	2900143	585
						VIP-3/PT/HD26SUB/M	2904269	576	VIP-CAB-FLK40-0,14/...	2318855	582
						VIP-3/PT/HD44SUB/F	2904274	576	VIP-CAB-FLK40/0,14/1,0M	2318790	582
						VIP-3/PT/HD44SUB/M	2904270	576	VIP-CAB-FLK40/0,14/2,0M	2318813	582
						VIP-3/PT/HD62SUB/F	2904275	576	VIP-CAB-FLK40/0,14/3,0M	2318826	582
						VIP-3/PT/HD62SUB/M	2904271	576	VIP-PA-FLK14-S7/...	2900887	501
						VIP-3/PT/PDM-2/16	2903797	598	VIP-PA-FLK14/ 0,5M/S7	2322663	501
						VIP-3/PT/PDM-2/24	2903798	598	VIP-PA-FLK14/ 1,0M/S7	2322676	501
						VIP-3/PT/PDM-2/32	2903799	598	VIP-PA-FLK14/ 1,5M/S7	2322689	501
						VIP-3/PT/PDM-2/48	2903800	598	VIP-PA-FLK14/ 2,0M/S7	2321790	501
						VIP-3/PT/RJ45	2904290	577	VIP-PA-FLK14/ 2,5M/S7	2322692	501
						VIP-3/SC/2FLK14/AN/2P/S7-1500A	2908464	513	VIP-PA-FLK14/ 3,0M/S7	2322702	501
						VIP-3/SC/2FLK14/AN/2P/S7-1500B	2908845	513	VIP-PA-FLK14/ 4,0M/S7	2322715	501
						VIP-3/SC/D25SUB/M	2315188	571	VIP-PA-FLK14/10,0M/S7	2322728	501
						VIP-3/SC/D25SUB/F/LED	2322210	571	VIP-PA-FLK14/ 6,0M/S7	2322731	501
						VIP-3/SC/D25SUB/M	2315133	571	VIP-PA-FLK14/ 7,0M/S7	2322744	501
						VIP-3/SC/D25SUB/F/LED	2322168	571	VIP-PA-FLK14/ 8,0M/S7	2322757	501
						VIP-3/SC/D37SUB/F	2315191	571	VIP-PA-FLK14/10,0M/S7	2322760	501
						VIP-3/SC/D37SUB/F/LED	2322223	571	VIP-PA-FLK50-4X14-S7/...	2900886	501
						VIP-3/SC/D37SUB/M	2315146	571	VIP-PA-FLK50-S7/...	2900885	500
						VIP-3/SC/D37SUB/M/HW/C300	2900675	487	VIP-PA-FLK50/ 0,5M/S7	2322443	500
						VIP-3/SC/D37SUB/M/LED	2322171	571	VIP-PA-FLK50/ 1,0M/S7	2322456	500
						VIP-3/SC/D50SUB/F	2315201	571	VIP-PA-FLK50/ 1,5M/S7	2322469	500
						VIP-3/SC/D50SUB/F/LED	2322236	571	VIP-PA-FLK50/ 2,0M/S7	2321800	500

Index

Alphabetical

Type	Order No.	Page	Type	Order No.	Page	Type	Order No.	Page
VIP-PA-FLK50/ 2,5M/S7	2322472	500	VIP-PA-PWR/4X10 PT/10,0M/S7	2905526	496			
VIP-PA-FLK50/ 3,0M/S7	2322485	500	VIP-PA-PWR/4X10COMBI/ 0,5M/S7	2904702	496			
VIP-PA-FLK50/ 4,0M/S7	2322498	500	VIP-PA-PWR/4X10COMBI/ 1,0M/S7	2904703	496			
VIP-PA-FLK50/ 5,0M/S7	2322508	500	VIP-PA-PWR/4X10COMBI/ 1,5M/S7	2904704	496			
VIP-PA-FLK50/ 6,0M/S7	2322511	500	VIP-PA-PWR/4X10COMBI/ 2,0M/S7	2904705	496			
VIP-PA-FLK50/ 7,0M/S7	2322524	500	VIP-PA-PWR/4X10COMBI/ 2,5M/S7	2904706	496			
VIP-PA-FLK50/ 8,0M/S7	2322537	500	VIP-PA-PWR/4X10COMBI/ 3,0M/S7	2904707	496			
VIP-PA-FLK50/10,0M/S7	2322540	500	VIP-PA-PWR/4X10COMBI/ 4,0M/S7	2904708	496			
VIP-PA-FLK50/4X14/ 0,5M/S7	2322553	501	VIP-PA-PWR/4X10COMBI/ 5,0M/S7	2904709	496			
VIP-PA-FLK50/4X14/ 1,0M/S7	2322566	501	VIP-PA-PWR/4X10COMBI/ 6,0M/S7	2904710	496			
VIP-PA-FLK50/4X14/ 1,5M/S7	2322579	501	VIP-PA-PWR/4X10COMBI/ 8,0M/S7	2904711	496			
VIP-PA-FLK50/4X14/ 2,0M/S7	2321910	501	VIP-PA-PWR/4X10COMBI/10,0M/S7	2904712	496			
VIP-PA-FLK50/4X14/ 2,5M/S7	2322582	501	VIP-PT/FLK16/DS/FU/LED/AN/DV	2903599	482			
VIP-PA-FLK50/4X14/ 3,0M/S7	2322595	501	VIP/S/BASE 3L DIVIDER	2907715	553			
VIP-PA-FLK50/4X14/ 4,0M/S7	2322605	501	VIP/S/D25M/BASE 1-8/L/EX	2906595	552			
VIP-PA-FLK50/4X14/ 5,0M/S7	2322618	501	VIP/S/MC/BASE 1-8/L/C/EX	2907186	553			
VIP-PA-FLK50/4X14/ 6,0M/S7	2322621	501	VIP/S/MC/BASE 1-8/L/EX	2906596	553			
VIP-PA-FLK50/4X14/ 7,0M/S7	2322634	501	VIP/S/MC/BASE 17-24/L/C/EX	2907209	553			
VIP-PA-FLK50/4X14/ 8,0M/S7	2322647	501	VIP/S/MC/BASE 17-24/L/EX	2907024	553			
VIP-PA-FLK50/4X14/10,0M/S7	2322650	501	VIP/S/MC/BASE 25-32/L/C/EX	2907210	553			
VIP-PA-PWR/20XOE/ 1,0M/S7	2904724	499	VIP/S/MC/BASE 25-32/L/EX	2907025	553			
VIP-PA-PWR/20XOE/ 2,0M/S7	2904725	499	VIP/S/MC/BASE 9-16/L/C/EX	2907187	553			
VIP-PA-PWR/20XOE/ 3,0M/S7	2904726	499	VIP/S/MC/BASE 9-16/L/EX	2906630	553			
VIP-PA-PWR/20XOE/ 4,0M/S7	2904727	499	VIP/U/RAIL 3L DIVIDER	2908555	553			
VIP-PA-PWR/20XOE/ 6,0M/S7	2904728	499	VS-937/...	1402611	50			
VIP-PA-PWR/20XOE/ 8,0M/S7	2904729	499						
VIP-PA-PWR/20XOE/10,0M/S7	2904730	499						
VIP-PA-PWR/20XOE/HF/ 1,0M/S7	2908916	499						
VIP-PA-PWR/20XOE/HF/ 2,0M/S7	2908915	499						
VIP-PA-PWR/20XOE/HF/ 3,0M/S7	2908914	499						
VIP-PA-PWR/20XOE/HF/ 4,0M/S7	2908913	499						
VIP-PA-PWR/20XOE/HF/ 6,0M/S7	2908912	499						
VIP-PA-PWR/20XOE/HF/ 8,0M/S7	2908911	499	ZB 15:UNBEDRUCKT	0811972	366			
VIP-PA-PWR/20XOE/HF/10,0M/S7	2908910	499	ZB 5 :UNBEDRUCKT	1050004	366			
VIP-PA-PWR/2X10 PT/ 0,5M/S7	2905528	497	ZB 6, LGS.FORTL.ZAHLEN	1051016	424			
VIP-PA-PWR/2X10 PT/ 1,0M/S7	2905529	497	ZB 6:UNBEDRUCKT	1051003	366			
VIP-PA-PWR/2X10 PT/ 1,5M/S7	2905531	497						
VIP-PA-PWR/2X10 PT/ 2,0M/S7	2905532	497						
VIP-PA-PWR/2X10 PT/ 2,5M/S7	2905533	497						
VIP-PA-PWR/2X10 PT/ 3,0M/S7	2905534	497						
VIP-PA-PWR/2X10 PT/ 4,0M/S7	2905535	497						
VIP-PA-PWR/2X10 PT/ 5,0M/S7	2905536	497						
VIP-PA-PWR/2X10 PT/ 6,0M/S7	2905537	497						
VIP-PA-PWR/2X10 PT/ 8,0M/S7	2905538	497						
VIP-PA-PWR/2X10 PT/10,0M/S7	2905539	497						
VIP-PA-PWR/2X10COMBI/ 0,5M/S7	2904713	497						
VIP-PA-PWR/2X10COMBI/ 1,0M/S7	2904714	497						
VIP-PA-PWR/2X10COMBI/ 1,5M/S7	2904715	497						
VIP-PA-PWR/2X10COMBI/ 2,0M/S7	2904716	497						
VIP-PA-PWR/2X10COMBI/ 2,5M/S7	2904717	497						
VIP-PA-PWR/2X10COMBI/ 3,0M/S7	2904718	497						
VIP-PA-PWR/2X10COMBI/ 4,0M/S7	2904719	497						
VIP-PA-PWR/2X10COMBI/ 5,0M/S7	2904720	497						
VIP-PA-PWR/2X10COMBI/ 6,0M/S7	2904721	497						
VIP-PA-PWR/2X10COMBI/ 8,0M/S7	2904722	497						
VIP-PA-PWR/2X10COMBI/10,0M/S7	2904723	497						
VIP-PA-PWR/40XOE/ 1,0M/S7	2904731	498						
VIP-PA-PWR/40XOE/ 2,0M/S7	2904732	498						
VIP-PA-PWR/40XOE/ 3,0M/S7	2904733	498						
VIP-PA-PWR/40XOE/ 4,0M/S7	2904734	498						
VIP-PA-PWR/40XOE/ 6,0M/S7	2904735	498						
VIP-PA-PWR/40XOE/ 8,0M/S7	2904736	498						
VIP-PA-PWR/40XOE/10,0M/S7	2904737	498						
VIP-PA-PWR/40XOE/HF/ 1,0M/S7	2908909	499						
VIP-PA-PWR/40XOE/HF/ 2,0M/S7	2908908	499						
VIP-PA-PWR/40XOE/HF/ 3,0M/S7	2908907	499						
VIP-PA-PWR/40XOE/HF/ 4,0M/S7	2908905	499						
VIP-PA-PWR/40XOE/HF/ 6,0M/S7	2908904	499						
VIP-PA-PWR/40XOE/HF/ 8,0M/S7	2908903	499						
VIP-PA-PWR/40XOE/HF/10,0M/S7	2908902	499						
VIP-PA-PWR/4X10 PT/ 0,5M/S7	2905516	496						
VIP-PA-PWR/4X10 PT/ 1,0M/S7	2905517	496						
VIP-PA-PWR/4X10 PT/ 1,5M/S7	2905518	496						
VIP-PA-PWR/4X10 PT/ 2,0M/S7	2905519	496						
VIP-PA-PWR/4X10 PT/ 2,5M/S7	2905520	496						
VIP-PA-PWR/4X10 PT/ 3,0M/S7	2905521	496						
VIP-PA-PWR/4X10 PT/ 4,0M/S7	2905522	496						
VIP-PA-PWR/4X10 PT/ 5,0M/S7	2905523	496						
VIP-PA-PWR/4X10 PT/ 6,0M/S7	2905524	496						
VIP-PA-PWR/4X10 PT/ 8,0M/S7	2905525	496						

For up-to-date modifications or supplements
to the catalog contents, please visit:
phoenixcontact.net/webcode/#0132

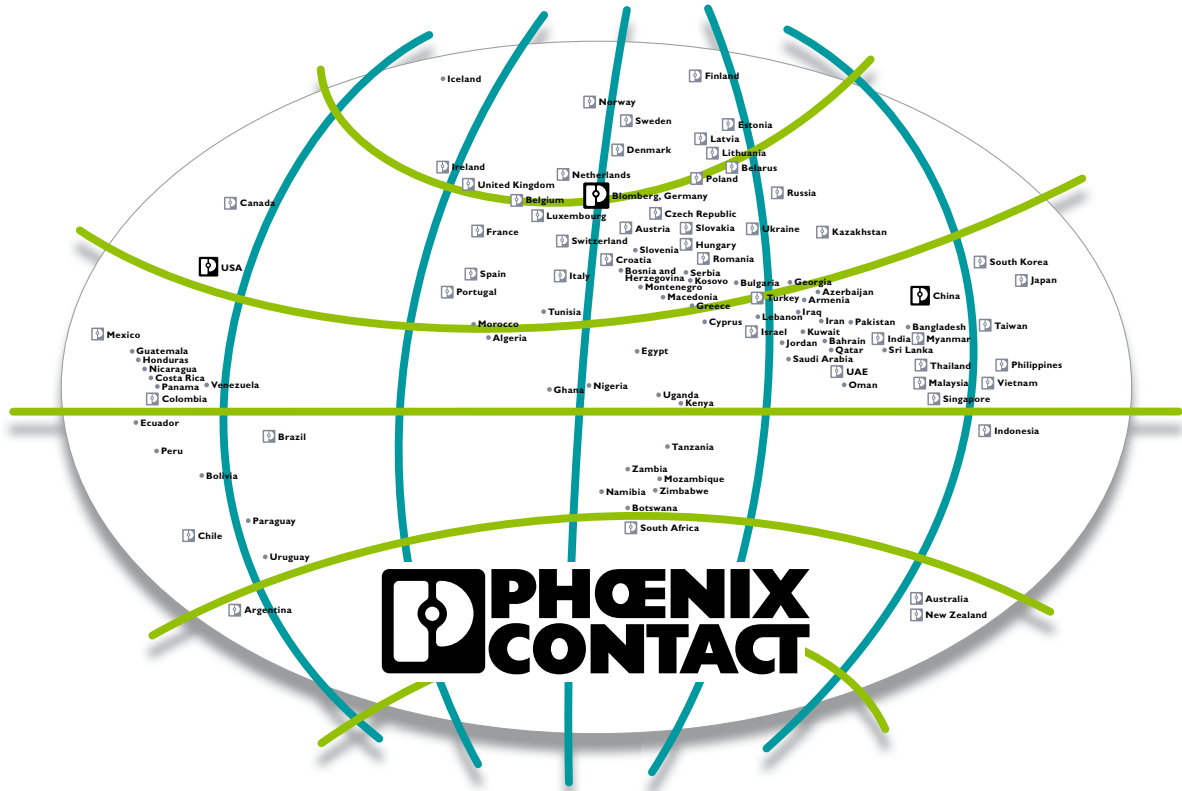

PROUDLY DISTRIBUTED BY



03 5278 8222

sales@factorycontrols.com.au

www.factorycontrols.com.au

65 Douro Street, North Geelong Victoria 3215



INSPIRING INNOVATIONS